

# MAF501 series

## AIR UNIT (FILTER)

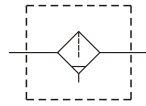

### Symbol



### Specification

Model	MAF501	
Bore No.	20A	25A
Port size	3/4	1
Medium	Air	
Operating pressure range (*)	Nylon bowl, PC bowl: 0.05~1 MPa	
	Metal bowl: 0.05~1.5 MPa	
Proof pressure	Nylon bowl, PC bowl: 1.5 MPa	
	Metal bowl: 2 MPa	
Ambient temperature	- 5~+60°C (No freezing)	
Filter element	40 μm	
Drain capacity	Nylon bowl, PC bowl: 75 cm <sup>3</sup>	
	Metal bowl: 70 cm <sup>3</sup>	
Weight	Nylon bowl, PC bowl: 1180g	
	Metal bowl: 1300g	

\* Standard unit contains semi-auto-drain function when operating pressure below 0.05 MPa.

\* Choose auto-drain FMRF300, the pressure range is 0.15~1 MPa.

### Order example

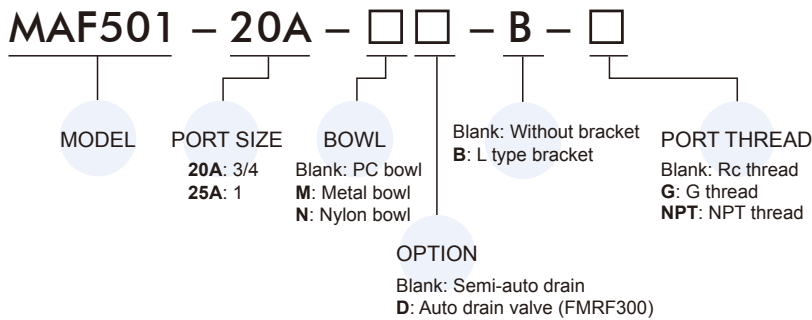

### Option accessories

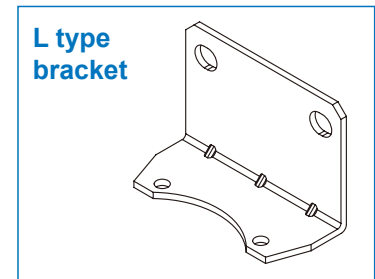

### Flow feature

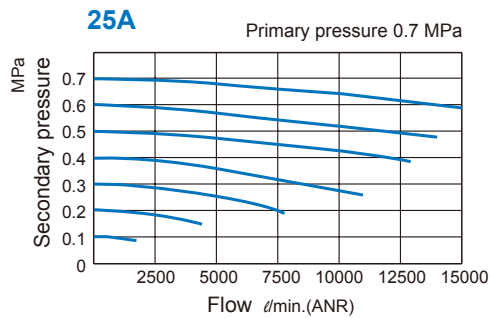
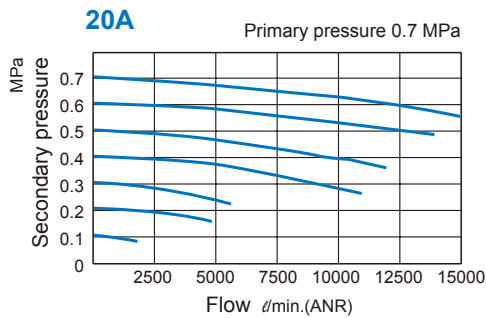

# MAF501 Dimensions

## AIR UNIT (FILTER)



### MAF501-D

Auto drain valve

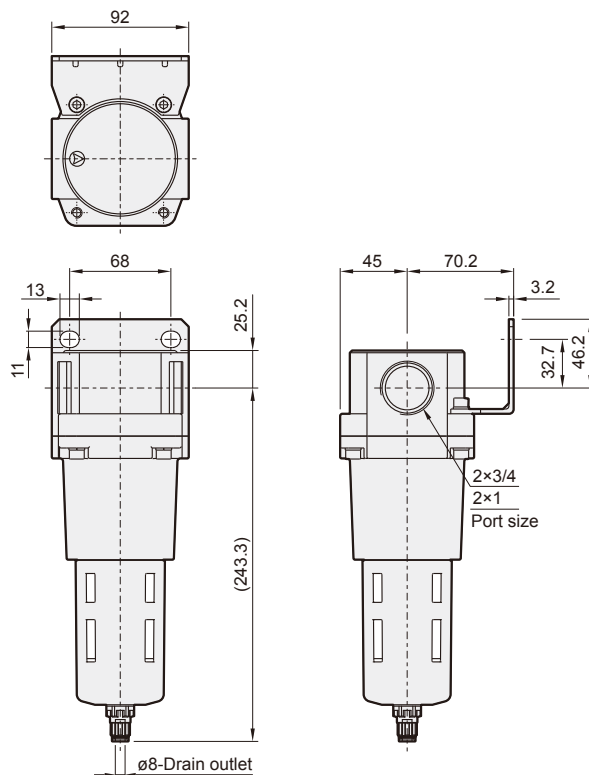
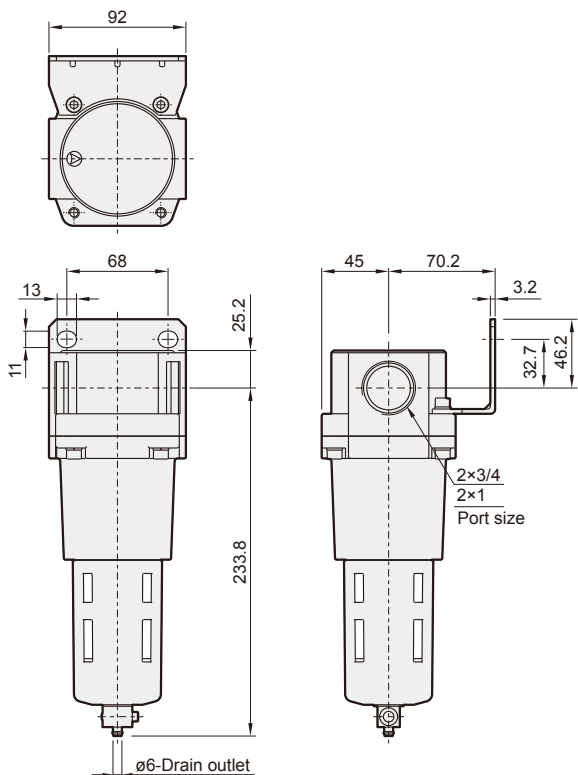

### MAF501-M

Metal bowl

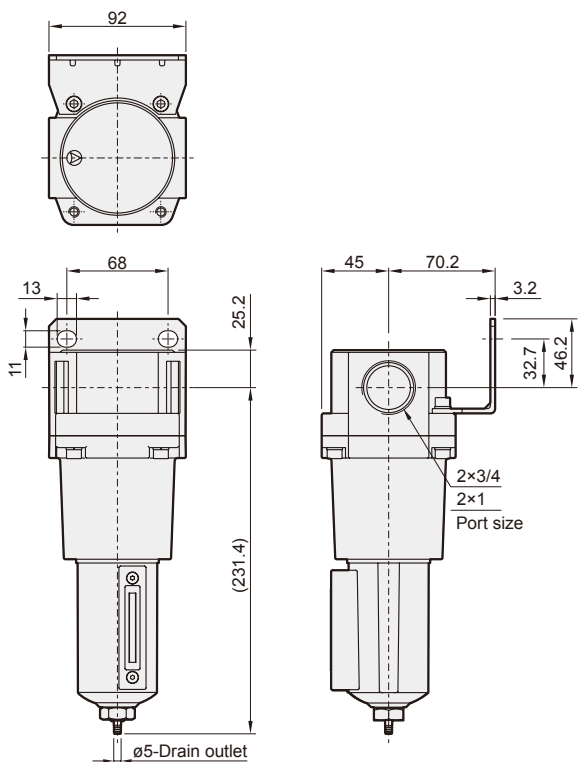

### MAF501-MD

Metal bowl + auto drain valve

