

Regulators

Ordering Information

*Additional configurations available upon request.

A	B	-	C	D	-	E	F	-	G	H	I	-	J	Standard feature
SM	PR1	-	VF	4	-	06	03	-	06	C	03	-	P	Optional

A	Materials
SM	316L Stainless steel
DM	316L Stainless steel VAR

B	Type
PR1	Regulator PR1 series
PR2	Regulator PR2 series

C	Connection Type
VM	Male BVC
VF	Female BVC
TW	Butt Weld
S	SUPERLOK Tube Fitting

D	Connection Size			
	Designator	Nominal Size	Outside Diameter	Wall Thickness
	4	1/4 in.	6.35 mm	1.00 mm
	6	3/8 in.	9.53 mm	1.00 mm
	8	1/2 in.	12.7 mm	1.24 mm

E	Maximum Inlet Pressure
06	600 psig (41.4 bar)
10	1000 psig (69 bar)
35	3500 psig (241 bar)

F	Outlet Pressure
03	30 psig (2.1 bar)
06	60 psig (41.4 bar)
10	100 psig (6.9 bar)
15	150 psig (10.3 bar)
25	250 psig (17.3 bar)

G	Inlet Gauge
	Leave Blank : regulator <i>without</i> gauge.
06	600 psig
10	1000 psig
35	3500 psig
40	4000 psig

H	Gauge Port
	See Gauge Port Configuration for the figures on page 83
A	Figure A
B	Figure B
C	Figure C
D	Figure D

I	Outlet Gauge
03	0 ~ 30 psig
06	0 ~ 60 psig
10	0 ~ 100 psig
16	0 ~ 160 psig
20	0 ~ 200 psig
30	0 ~ 300 psig

J	Wetted Surface Grade
	BA is standard. No part designator needed.
P	EP

Regulators

PR1 Series



Part Number Examples

	DMPR1-VF4-0603-B03		DMPR1-VM4-1010-10C16-P	
Material	DM	316L Stainless Steel VAR	DM	316L Stainless Steel VAR
Type	PR1	PR1 series	PR1	PR1 series
Connection Type	VF	BVC Female	VM	BVC Male
Connection Size	4	1/4"	4	1/4"
Max. Inlet Pressure	06	600 psig (41.4 bar)	10	1000 psig (69 bar)
Outlet Pressure	03	30 psig (2.1 bar)	10	100 psig (6.9 bar)
Inlet Gauge		W/O inlet gauge	10	1000 psig
Gauge Port*	B	Fig.B of Gauge Port Configurations, page 83	C	Fig.C of Gauge Port Configurations, page 83
Outlet Gauge	03	0~30 psig	16	0~160 psig
Grade		BA grade (standard)	P	EP grade

*NOTE: See *Gauge Port Configurations* on page 83.

Specifications

Size	1/4"
Cv Value	0.06 or 0.2
Surface finish (Ra)	10µin or 5µin
Max. rated inlet pressure	600, 1000, 3500 psig (41.4, 69, 241 bar)
Outlet pressure ranges	30, 60, 100, 150, 250 psig (2.1, 4.1, 6.9, 10.3, 17.3 bar)
Design proof pressure	150% of Maximum rated pressure
Max. Working Temperature	PCTFE: -26~80°C (-15~176°F) / PFA, PI: -26~150°C (-15~302°F)
External Leakage Allowance (He) (Holding Time ≥ 1 min.)	≤1x10 ⁻⁹ atm.cc/s
Particle Inspection (EP Only) (0.1µm and Larger)	No count

Material

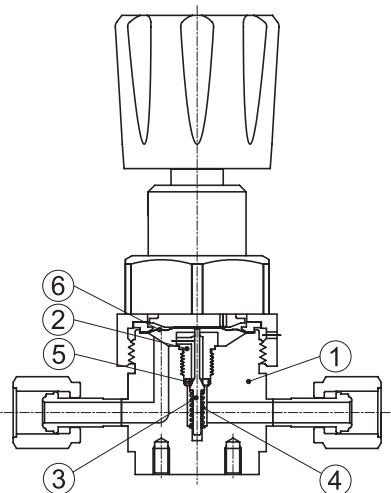

No.	Component	Material
1	Body	316L Stainless Steel
		316L Stainless Steel VAR
2	Seat Holder	316L Stainless Steel
3	Main Valve	316L Stainless Steel
4	Valve Spring	Inconel 750
5	Seat	PCTFE (standard) / PFA / PI
6	Diaphragm	Ni-Co Alloy

NOTE:

- Dimensions and Drawings are for reference only and are subject to change without prior notice.
- Unless otherwise specified, all dimensions are in millimeters.

Dimensions

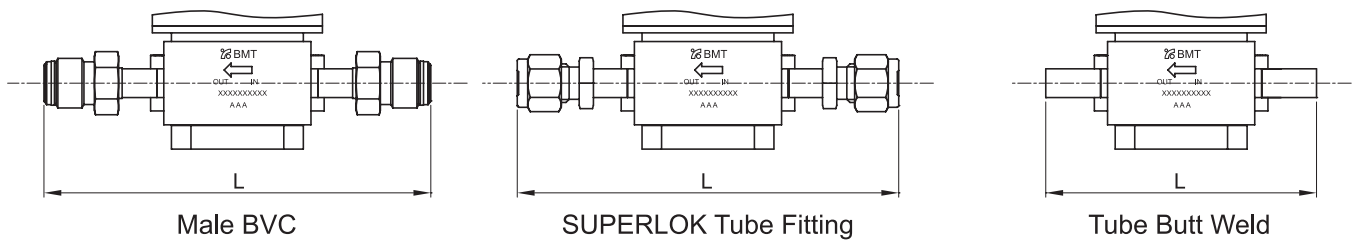
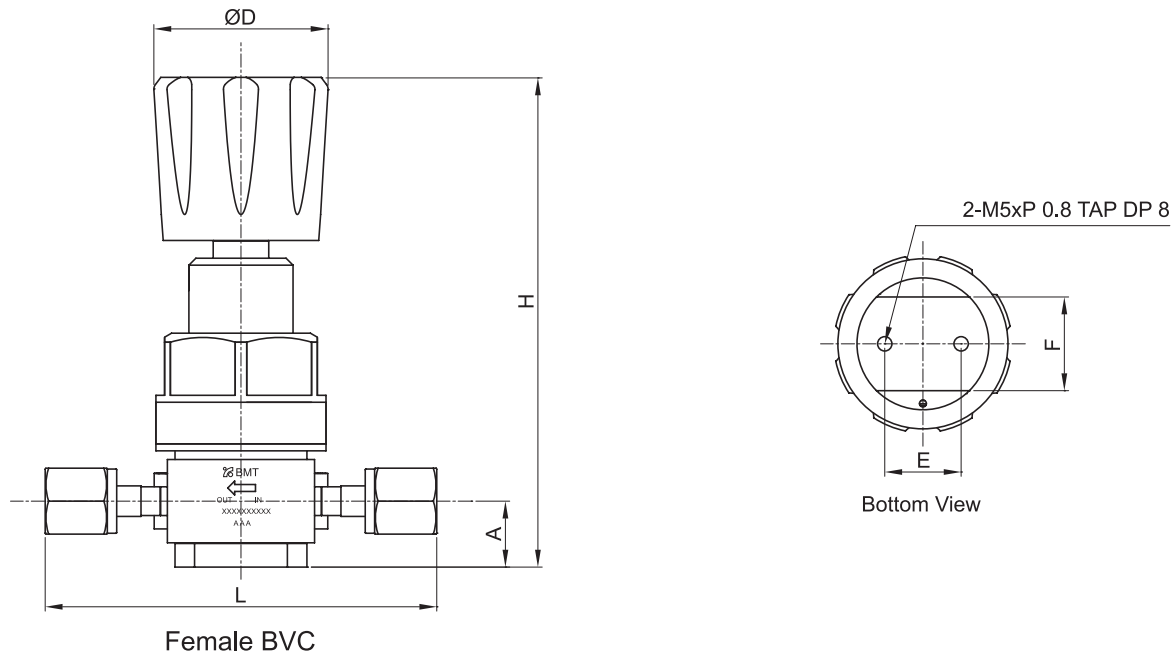

End Connection	Part No.	Dimensions (mm)					
		L	H	A	E	F	D
Male BVC	SMPR1-VM4	114	134	19	22	27	52
Female BVC	SMPR1-VF4	94					
SUPERLOK Tube Fitting	SMPR1-S4	111					
Butt Weld	SMPR1-TW4	76					

NOTE:
 ·Dimensions and Drawings are for reference only and are subject to change without prior notice.
 ·Unless otherwise specified, all dimensions are in millimeters.