

Block & Bleed Valves

- Double Block & Bleed Valves
- Monoflange Valves

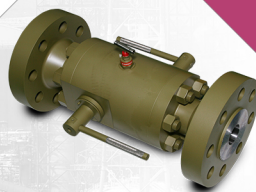
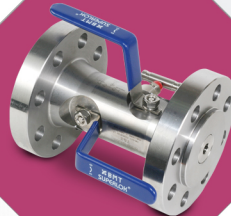
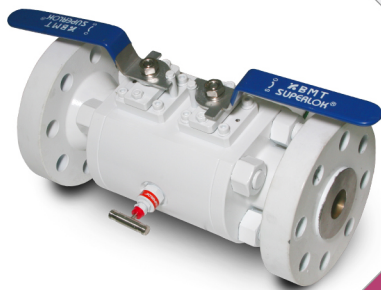
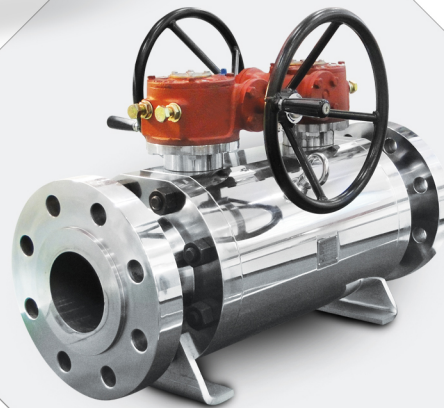

Introduction

BMT (SUPERLOK®)'s response to the demand for reduction in leakage paths has been the combination of primary and secondary valves into one compact unit. The combining of piping and instrument valves into a single unit has benefitted various markets.

BMT (SUPERLOK®) can offer the special combination of double block and bleed valve systems together with fittings, both being designed and produced in-house. Choice of this combination results in the elimination of taper thread connections and the need for thread sealant.

Application & Installation

BMT Block & Bleed Valves incorporate up to 3 ball valves or mixture of ball and needle design into a single valve unit. One compact unit reduces the need for Large, Complicated, Costly Multi-Valve Systems. Removing Connections between separate units result in fewer potential leak paths. A vent valve allows to check the integrity of seat seals and permits withdrawal of fluid leakage increasing safety and ease of maintenance.

Conventional Installation <1>

A welded flange, connected to a primary ANSI class isolating valve. The primary valve will be connected to a secondary instrument valve. A pressure gauge or transmitter will then be installed downstream of the instrument valve.

Block & Bleed Valve <2>

- A one-piece integral unit incorporating up to 3 ball valve or mixture of ball and needle design.
- Improved safety : leak paths reduced by up to 60%
- Reduced costs : installation and component costs reduced by up to 70%
- Reduced weight : by up to 80%
- Reduced susceptibility to problems caused by vibration.

Monoflange Valve <3>

- More compact than DBB valve, adding further space and weight saving possibilities.
- Improved safety : leak paths reduced by up to 60%, less susceptibility to vibration
- Reduced costs : installation and component costs saving up to 80%
- Reduced weight : up to 85%

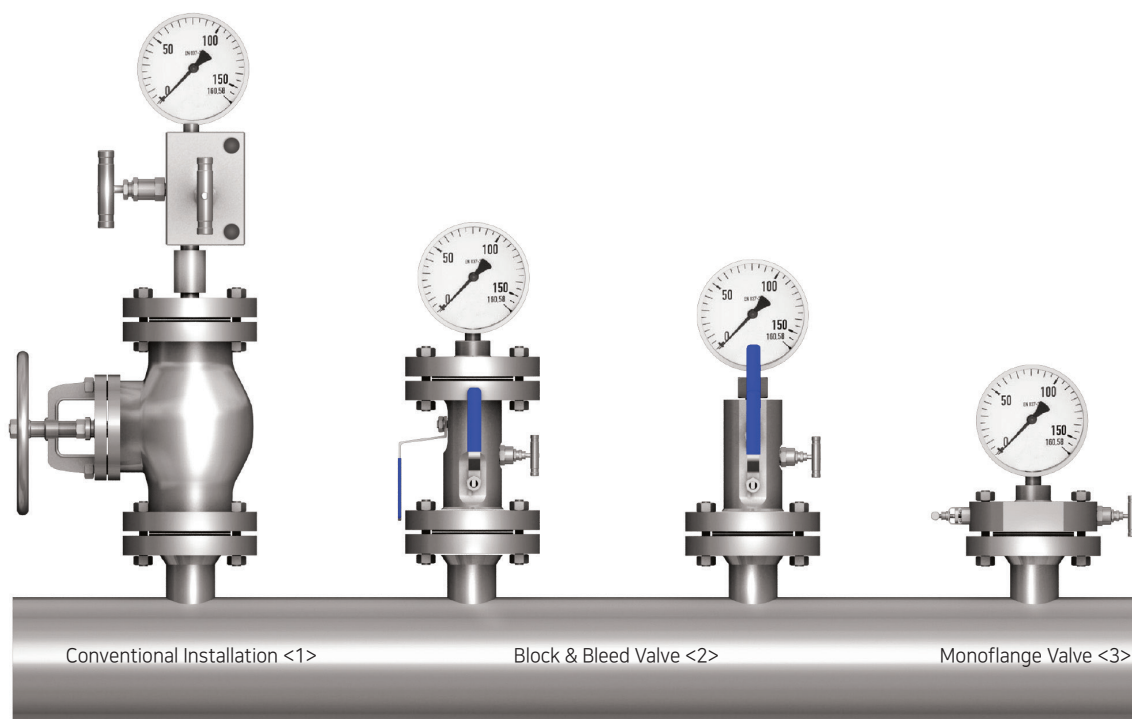

Ball Valve

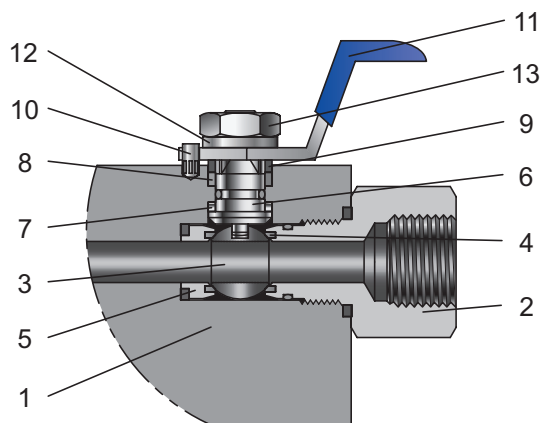

Materials of Construction

COMPONENT	BODY MATERIAL		
	STAINLESS STEEL	CARBON STEEL	DUPLEX STAINLESS STEEL
1 VALVE BODY	A182 F316	A350 LF2	A182 F51
2 OULET CONNECTOR	A276 TP316	A350 LF2	A182 F51
3 BALL	A479 TP316		S31803
4 BALL SEAT	PTFE / R.PTFE / PEEK / ETC		
5 SEAT CAPSULE	A276 TP316		S31803
6 STEM	A276 TP316, SS630		S31803
7 LOWER STEM SEAL	PTFE		
8 UPPER STEM SEAL	GRAPHITE		
9 PACKING GLAND	A276 TP316		S31803
10 STOP PIN	A276 TP316		S31803
11 HANDLE	STAINLESS STEEL		
12 STEM WASHER	STAINLESS STEEL		
13 STEM NUT	A194 8M		

Technical Information

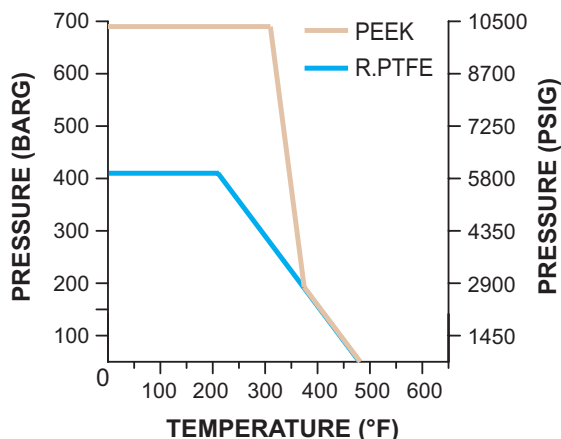

- 316 Stainless steel as standard.
- Pressure rating up to 10,000 psig (690bar).
- Temperature rating -71°F to 482°F (-57°C to 250°C).

Design codes

- ANSI / ASME B 16.34 - Designed to meet the pressure and temperature requirements
- ANSI / ASME B 16.5 - Flange dimensions
- ANSI / ASME B 1.20.1 - National pipe threads
- API 607 / BS 6755 - Fire safe designed

Features

- One piece or two piece body design -minimize leakage paths.
- Ball seat choice of seat materials : PTFE (virgin or filled), PCTFE, PEEK, DEVLON
- End connector threads are fully isolated from process.
- Fully encapsulated ball seat.
- Superior finished ball for low operating torque.
- Floating ball design providing seat wear compensation.
- Anti static design as standard.
- Blowout proof stem design.
- Colour coded & function identified handle.
- Bore size : Full bore, Reducer bore
- Optional : handle locking available, NACE compliance.

- Components can limit the pressure and temperature ranges of the valve. Please consult BMT (SUPERLOK) sales representative for your specific application.

Outside Screw and Yoke(OS&Y) Needle Valve

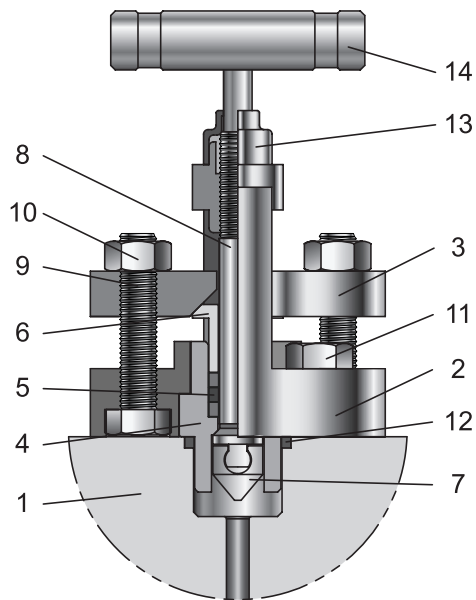

Materials of Construction

COMPONENT	BODY MATERIAL		
	STAINLESS STEEL	CARBON STEEL	DUPLEX STAINLESS STEEL
1 VALVE BODY	A182 F316	A350 LF2	A182 F51
2 OS & Y BONNET	A351 CF8M	A352 LCC	A182 F51
3 GLAND FLANGE	A351 CF8M	A352 LCC	A182 F51
4 INSERT	A276 TP316		S31803
5 PACKING	GRAPHITE		
6 BUSHING	A276 TP316		S31803
7 VEE TIP	A564 TP630		
8 STEM	A276 TP316		S31803
9 FLANGE BOLT	A193 B8M	A320 L7M	A453 Gr.660
10 FLANGE NUT	A194 8M	A194 Gr.7	
11 BONNET BOLT	A193 B8M	A320 L7M	
12 BONNET SEAL	GRAPHITE		
13 DUST CAP	NYLON		
14 BAR HANDLE	A276 TP316		S31803

Technical Information

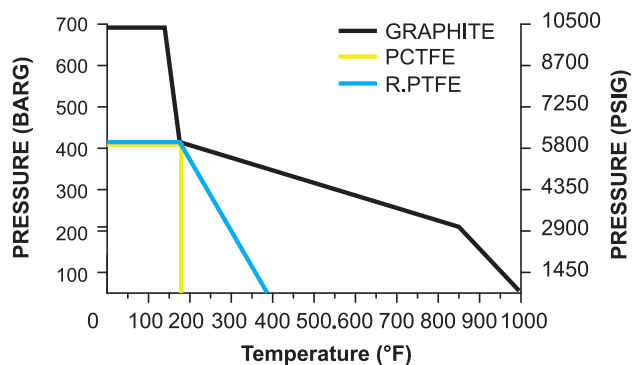

- 316 Stainless steel as standard.
- Pressure rating up to 10,000 psig (690bar).
- Temperature rating -65°F to 1000°F (-54°C to 538°C).

Features

- Externally adjustable gland.
- PTFE or Graphite packing for bubble tight sealing.
- Self centering crimped needle tip for bubble tight shut off and repeatability.
- Back seat design provides secondary stem sealing and prevents stem blow out.
- Colour coded close contact dust cap and function label for easy identification.
- Bonnet seal ensure a bubble tight between body and bonnet.
- Stem threads are completely isolated from the process.
- Yoke of investment casting is precision casted for strength and perfect stem alignment.
- Bolted bonnet for strength.

- Components can limit the pressure and temperature ranges of the valve. Please consult BMT (SUPERLOK) sales representative for your specific application.

Globe Style Needle Valve

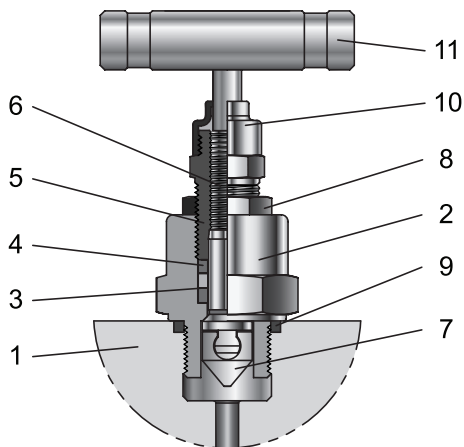

Materials of Construction

COMPONENT	BODY MATERIAL		
	STAINLESS STEEL	CARBON STEEL	DUPLEX STAINLESS STEEL
1 BODY	A276 TP316	A350 LF2	A182 F51
2 BONNET	A276 TP316	A350 LF2	A182 F51
3 PACKING	GRAPHITE		
4 PACKING GLAND	A276 TP316		S31803
5 PACKING BOLT	A276 TP316	A350 LF2	S31803
6 STEM	A276 TP316		S31803
7 VEE TIP	A564 TP630		
8 LOCK NUT	A276 TP316	A350 LF2	S31803
9 BONNET SEAL	GRAPHITE		
10 DUST CAP	NYLON		
11 BAR HANDLE	A276 TP316		S31803

Technical Information

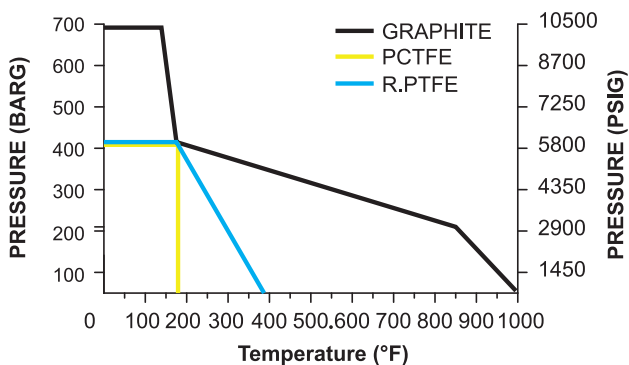

- 316 Stainless steel as standard.
- Pressure rating up to 10,000 psig (690bar).
- Temperature rating -65°F to 1000°F (-54°C to 538°C).

Features

- Rolled stem operating threads for low torque operation.
- Gland packing in PTFE or Graphite for bubble tight sealing.
- Colour coded close contact dust cap and function label for easy identification.
- Self centering crimped needle tip for bubble tight seat sealing.
- Close contact dust cap for operating thread protection.
- Back seat design provides secondary stem sealing and prevents stem blowout.
- Stem threads are completely isolated from the process.
- Packing bolt with easy access.
- Lock nut for vibration protection.

- Components can limit the pressure and temperature ranges of the valve. Please consult BMT (SUPERLOK) sales representative for your specific application.

Block & Bleed Valves

Features

- ANSI /ASME B16.5 flanged inlet connections, sizes from 1/2" to 16", rated from Class 150 to 2,500.
- 1/2" to 1" F.NPT Thread outlet to ANSI/ASME B1.20.1(dependent on bore size).
- 1/2" F.NPT Thread vent connection to ANSI/ASME B1.20.1
- Stainless steel as the standard body material. Optional materials include Super Duplex, Monel, Hastelloy, Inconel.
- Raised face and ring type joint flange styles.
- One-piece forged construction flange as standard.
- Fire safe designed (and tested) to meet BS 6755 Part 2/API 607.
- DBB & SBB Products meet the relevant code requirement of ASME VIII, ANSI /ASME B 16.34, B16.5, B31.3 and API 6D.
- Bubble tight shut off.
- locking and anti tamper devices for all valve types available option.
- Positive lever stop.
- User preferred handles.
- Permanent affixed reference label.



DB1 Series(Flange x FNPT)

Table of Dimensions

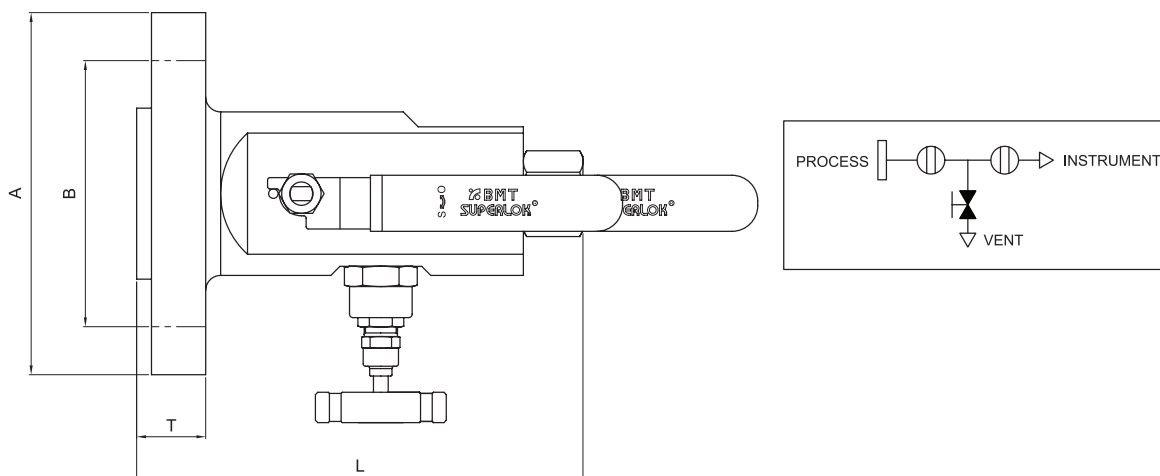

(10mm BORE)

Size (inch)	Rating (lb)	Dimension			
		L (RF)	A	B	T(RF)
1/2 (DN15)	150	170	90	60.3	11.6
	300		95	66.7	14.7
	600	177	95		21.3
	900/1500	191	120	82.5	29.3
	2500	195	135	88.9	37.2
3/4 DN(20)	150	170	100	69.8	13.2
	300	170	115	82.5	16.3
	600	175	115		22.9
	900/1500	190	130	88.9	32.4
	2500	195	140	95.2	38.8
1 (DN25)	150	170	110	79.4	14.7
	300		125	88.9	17.9
	600	175	125		24.5
	900/1500	190	150	101.6	35.6
	2500	205	160	108.0	42.0
1-1/2 (DN40)	150	170	125	98.4	17.9
	300	175	155	114.3	21.1
	600	180	155		29.3
	900/1500	190	180	124.0	38.8
	2500	210	205	146.1	51.5
2 (DN50)	150	172	150	120.6	19.5
	300	177	165	127.0	22.7
	600	190			32.4
	900/1500	202	202	165.1	45.1
	2500	213	213	171.5	57.9

- Dimensions and Drawings are for reference only and are subject to change without prior notice.

- Unless otherwise specified, all dimensions are in millimeters.

- Sizes, pressure classes, and end connections not listed are available upon request.

Table of Dimensions

(14mm BORE)

Size (inch)	Rating (lb)	Dimension			
		L (RF)	A	B	T(RF)
3/4 DN(20)	150	205	100	69.8	13.2
	300		115	82.5	16.3
	600	210	115		22.9
	900/1500	225	130	88.9	32.4
	2500	230	140	95.2	38.8
1 (DN25)	150	208	110	79.4	14.7
	300		125	88.9	17.9
	600	218	125		24.5
	900/1500	224	150	101.6	35.6
	2500	227	160	108.0	42.0
1-1/2 (DN40)	150	218	125	98.4	17.9
	300		155	114.3	21.1
	600	218	155		29.3
	900/1500	224	180	124.0	38.8
	2500	238	205	146.1	51.5
2 (DN50)	150	218	150	120.6	19.5
	300		165	127.0	22.7
	600	224			32.4
	900/1500	238	215	165.1	45.1
	2500	246	235	171.5	57.9

(20mm BORE)

Size (inch)	Rating (lb)	Dimension			
		L (RF)	A	B	T(RF)
1 (DN25)	150	220	110	79.4	14.7
	300		125	88.9	17.9
	600	225	125		24.5
	900/1500	250	150	101.6	35.6
	2500	255	160	108.0	42.0
1-1/2 (DN40)	150	235	125	98.4	17.9
	300		155	114.3	21.1
	600	244	155		29.3
	900/1500	251	180	124.0	38.8
	2500	265	205	146.1	51.5
2 (DN50)	150	244	150	120.6	19.5
	300		165	127.0	22.7
	600	251			32.4
	900/1500	265	215	165.1	45.1
	2500	273	235	171.5	57.9

- Dimensions and Drawings are for reference only and are subject to change without prior notice.

- Unless otherwise specified, all dimensions are in millimeters.

- Sizes, pressure classes, and end connections not listed are available upon request.

DB2 Series(Flange x Flange)

Table of Dimensions

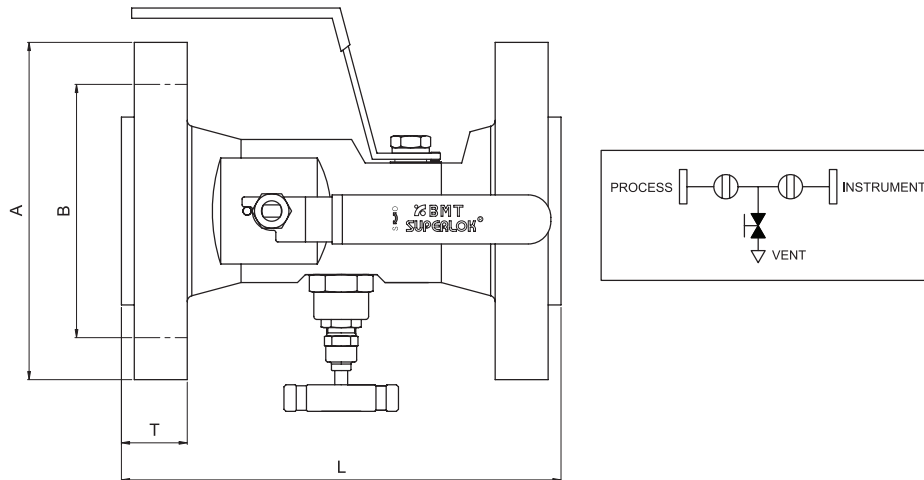

(10mm BORE)

Size (inch)	Rating (lb)	Dimension			
		L (RF)	A	B	T(RF)
1/2 (DN15)	150	190	90	60.3	11.6
	300	190	95	66.7	14.7
	600	205	95		21.3
	900/1500	230	120	82.5	29.3
	2500	240	135	88.9	37.2
3/4 DN(20)	150	190	100	69.8	13.2
	300	190	115	82.5	16.3
	600	200	115		22.9
	900/1500	230	130	88.9	32.4
	2500	240	140	95.2	38.8
1 (DN25)	150	190	110	79.4	14.7
	300	190	125	88.9	17.9
	600	200	125		24.5
	900/1500	230	150	101.6	35.6
	2500	260	160	108.0	42.0
1-1/2 (DN40)	150	190	125	98.4	17.9
	300	200	155	114.3	21.1
	600	210	155		29.3
	900/1500	240	180	124.0	38.8
	2500	290	205	146.1	51.5
2 (DN50)	150	190	150	120.6	19.5
	300	200	165	127.0	22.7
	600	230			32.4
	900/1500	280	215	165.1	45.1
	2500	305	235	171.5	57.9

- Dimensions and Drawings are for reference only and are subject to change without prior notice.

- Unless otherwise specified, all dimensions are in millimeters.

- Sizes, pressure classes, and end connections not listed are available upon request.

Table of Dimensions

(14mm BORE)

Size (inch)	Rating (lb)	Dimension			
		L (RF)	A	B	T(RF)
3/4 DN(20)	150	220	100	69.8	13.2
	300		115		16.3
	600	230	115	82.5	22.9
	900/1500	260	130	88.9	32.4
	2500	270	140	95.2	38.8
1 (DN25)	150	235	110	79.4	14.7
	300		125		17.9
	600	254	125	88.9	24.5
	900/1500	267	150	101.6	35.6
	2500	273	160	108.0	42.0
1-1/2 (DN40)	150	235	125	98.4	17.9
	300		155		21.1
	600	254	155	114.3	29.3
	900/1500	267	180	124.0	38.8
	2500	334	205	146.1	51.5
2 (DN50)	150	254	150	120.6	19.5
	300		165		22.7
	600	267	165	127.0	32.4
	900/1500	334	215	165.1	45.1
	2500		235	171.5	57.9

(20mm BORE)

Size (inch)	Rating (lb)	Dimension			
		L (RF)	A	B	T(RF)
1 (DN25)	150	250	110	79.4	14.7
	300	260	125		17.9
	600	280	125	88.9	24.5
	900/1500	360	150	101.6	35.6
	2500	410	160	108.0	42.0
1-1/2 (DN40)	150	235	125	98.4	17.9
	300		155		21.1
	600	254	155	114.3	29.3
	900/1500	268	180	124.0	38.8
	2500	334	205	146.1	51.5
2 (DN50)	150	254	150	120.6	19.5
	300		165		22.7
	600	173	165	127.0	32.4
	900/1500	334	215	165.1	45.1
	2500		235	171.5	57.9

- Dimensions and Drawings are for reference only and are subject to change without prior notice.

- Unless otherwise specified, all dimensions are in millimeters.

- Sizes, pressure classes, and end connections not listed are available upon request.

Table of Dimensions

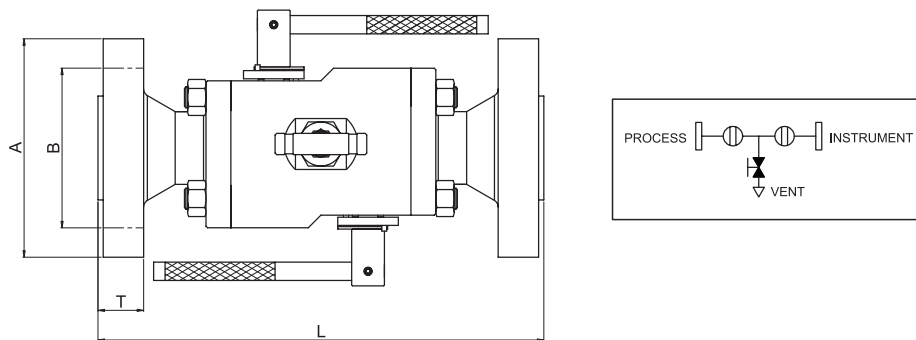

(REDUCED BORE)

Size (inch)	Bore	Rating (lb)	Dimension					
			RF Flange		RTJ Flange		A	B
			L	T	L	T		
1-1/2 (DN40)	25.4	150	270	17.9	280	22.7	125	98.4
		300	290	21.1	300	25.9	155	
		600	310	29.3	330	30.3	155	114.3
		900/1500	400	38.8	350	39.8	180	124.0
		2500	400	51.5	400	52.5	205	146.1
2 (DN50)	38.1	150	370	19.5	390	24.3	150	120.6
		300	380	22.7	400	27.5	165	127.0
		600	400	32.4	410	33.4		
		900/1500	490	45.1	450	46.1	215	165.1
		2500	490	57.9	490	58.9	235	171.5
3 (DN80)	50.8	150	530	24.3	540	29.1	190	152.4
		300	540	29.0	550	33.8	210	168.1
		600	560	38.8	560	39.9		

(FULL BORE)

Size (inch)	Bore	Rating (lb)	Dimension					
			RF Flange		RTJ Flange		A	B
			L	T	L	T		
1 (DN25)	25.4	150	270	14.7	280	19.5	110	79.4
		300	280	17.9	290	22.7	125	88.9
		600	300	24.5	300	25.5	125	
		900/1500	410	35.6	350	36.6	150	101.6
		2500	370	42.0	370	43.0	160	108.0
1-1/2 (DN40)	38.1	150	340	17.9	380	22.7	125	98.4
		300	380	21.1	410	25.9	155	114.3
		600	405	29.3	410	30.3	155	
		900/1500	430	38.8	430	39.8	180	124.0
		2500	470	51.5	470	52.5	205	146.1
2 (DN50)	50.8	150	350	19.5	470	24.3	150	120.6
		300	400	22.7	480	27.5	165	127.0
		600	430	32.4	490	33.4		
		900/1500	520	45.1	510	46.1	215	165.1

- Dimensions and Drawings are for reference only and are subject to change without prior notice.

- Unless otherwise specified, all dimensions are in millimeters.

- Sizes, pressure classes, and end connections not listed are available upon request.

OPTIONS

Sampling Valve

This manifold is designed to replace conventional multiple-valve installations where sampling of the process stream is required. This design has been developed to remove a sample directly from the process stream at full system pressure.

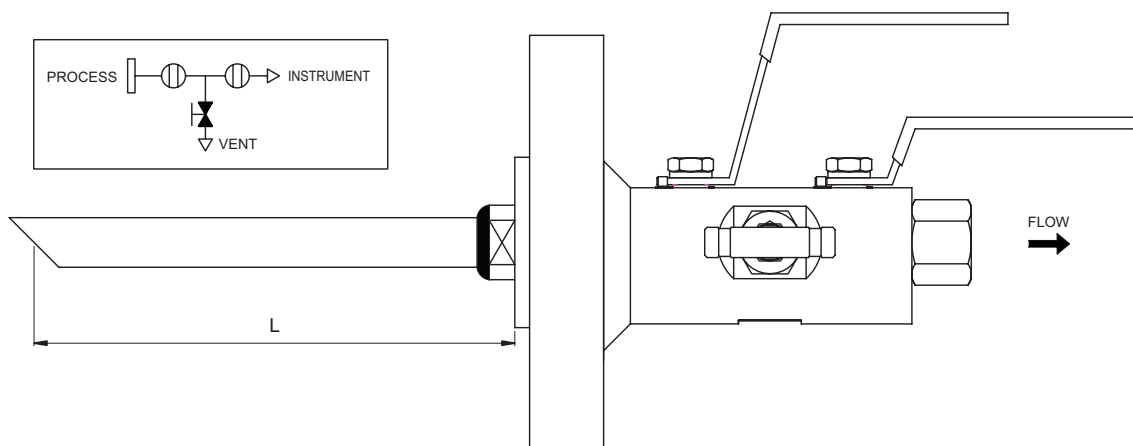

Sampling probe

The probe length must be specified from the raised face to the end of the probe.

Probes are supplied to suit the insertion length required by the pipeline and thus must be specified by the customer

Chemical Injection Valve

This manifold is designed to replace conventional multiple-valve installations where injection into the process stream is required. This design has been developed to inject directly into the process stream at full system pressure.

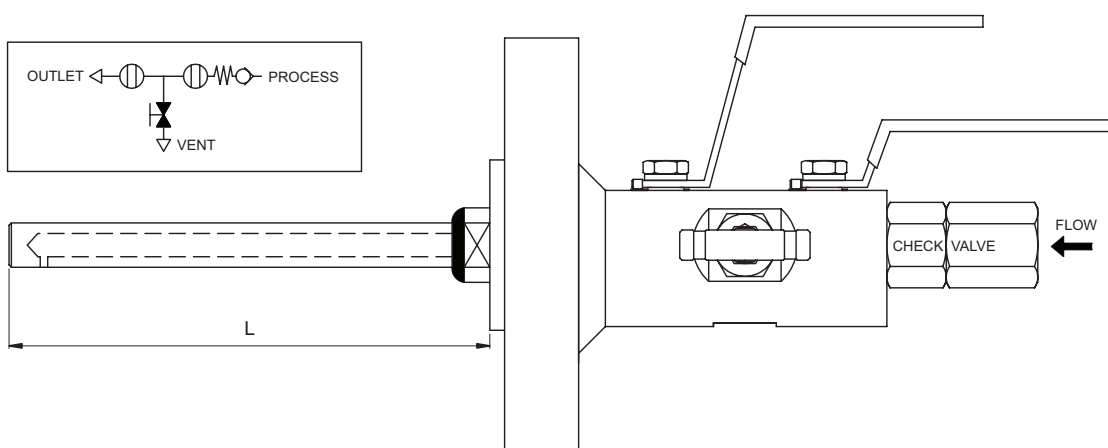

Injection quill

The quill length must be specified from the raised face to the end of the probe in mm.

Quill length shall be decided in consideration of injection insert length in the pipeline and customer's request.

Non return check valve

This poppet type spring return valve has a viton soft seal (SUPERLOK standard)

Fugitive Emission

ISO 15848 parts 1&2 (defining a classification system and qualification procedures, and production acceptance test of industrial valves, respectively) specify new ultra low standards for emissions, which effectively set a requirement for zero emissions for processes involving volatile air pollutants and hazardous fluids. This design has been developed to minimise fugitive emissions. This standard is becoming the requirement for oil and gas and petrochemical organizations worldwide.

The standard was originally created for process valves and control valves but is now being also applied to Instrument valves which include primary isolation valves, especially on environmentally sensitive projects. Meeting these low levels is a challenge, which BMT has solved with the new ball and needle valve designs used in these DBB valves and mono flanges.

Valve Specification

- Tightness class A $>1 \times 10^{-6}$ mg.s-1.m-1.
- Maximum cold working pressure rating 6,000 psig.
- Temperature rating -50°C to 180°C (-58°F to 356°F)
- ISO15848-1 prototype tested using global helium vacuum method.

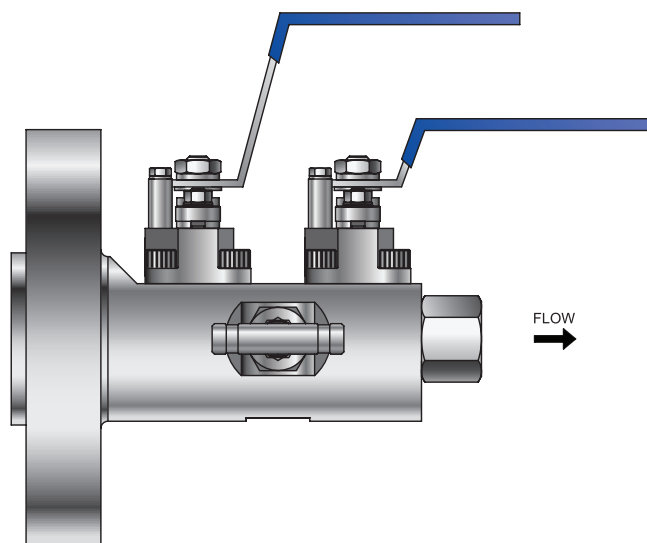
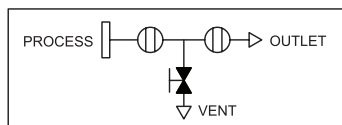
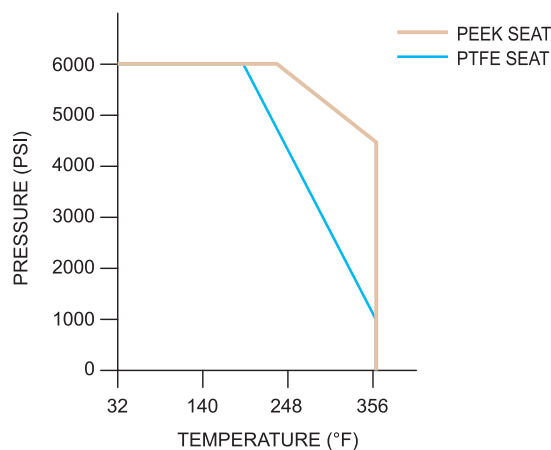

Cryogenic Service

Valves can be designed for cryogenic service.

Please refer to BMT catalog for Cryogenic Valves (BMT CRYOGENIC VALVE (EN) -R1 (190601)).

Attachment: Ordering Information for Block & Bleed Valves

Example 1 :

D	B	2	1	1	-	R	8	C	-	B	1	1	1	-	L	F	2
1	2	3	4			5	6			7					8		

Example 2 :

S	B	1	1	1	-	R	8	A	8	-	D	1	1	1	-	A	B
1	2	3	4			5	6	5			7					8	

1. Valves

- SB** = Single Block & Bleed Valve
- DB** = Double Block & Bleed Valve
- CSB** = Single Block & Bleed Valve for Cryogenic Service
- CDB** = Double Block & Bleed Valve for Cryogenic Service

2. Valve Type

- | | |
|--|---|
| <ul style="list-style-type: none"> <input type="checkbox"/> 1 = Flange x FNPT <input type="checkbox"/> 2 = Flange x Flange <input type="checkbox"/> 3 = MNPT x FNPT <input type="checkbox"/> 4 = FNPT x FNPT <input type="checkbox"/> 5 = Pipe x FNPT <input type="checkbox"/> 6 = SW x FNPT | <ul style="list-style-type: none"> <input type="checkbox"/> 7 = BW x FNPT <input type="checkbox"/> 8 = Pipe x Flange <input type="checkbox"/> 9 = MNPT x Flange <input type="checkbox"/> 0 = SW x SW <input type="checkbox"/> B = BW x BW |
|--|---|

4. Bore Size (mm)

- | | | | |
|--|---|--|--|
| <input type="checkbox"/> (Blank) = 10mm(Standard) | <input type="checkbox"/> 5 = 38mm | <input type="checkbox"/> 10 = 125mm | <input type="checkbox"/> 15 = 335mm |
| <input type="checkbox"/> 1 = 14mm | <input type="checkbox"/> 6 = 50mm | <input type="checkbox"/> 11 = 150mm | <input type="checkbox"/> 16 = 385mm |
| <input type="checkbox"/> 2 = 20mm | <input type="checkbox"/> 7 = 65mm | <input type="checkbox"/> 12 = 200mm | |
| <input type="checkbox"/> 3 = 25mm | <input type="checkbox"/> 8 = 80mm | <input type="checkbox"/> 13 = 250mm | |
| <input type="checkbox"/> 4 = 32mm | <input type="checkbox"/> 9 = 100mm | <input type="checkbox"/> 14 = 300mm | |

5. Connection Size

- | | |
|---|--|
| <ul style="list-style-type: none"> <input type="checkbox"/> R = Raised Face <input type="checkbox"/> J = Ring Type Joint <input type="checkbox"/> F = Flat Face Flange <input type="checkbox"/> AF = API-6B Type <input type="checkbox"/> SA = SAE J518 Flange <input type="checkbox"/> IS = ISO 6164 Flange <input type="checkbox"/> JF = JIS Flange | <ul style="list-style-type: none"> <input type="checkbox"/> 4 = 1/4" <input type="checkbox"/> 6 = 3/8" <input type="checkbox"/> 8 = 1/2" <input type="checkbox"/> 12 = 3/4" <input type="checkbox"/> 16 = 1" <input type="checkbox"/> 24 = 1-1/2" <input type="checkbox"/> 32 = 2" <input type="checkbox"/> 48 = 3" <input type="checkbox"/> 64 = 4" <input type="checkbox"/> 80 = 5" <input type="checkbox"/> 96 = 6" <input type="checkbox"/> 128 = 8" <input type="checkbox"/> 160 = 10" <input type="checkbox"/> 192 = 12" <input type="checkbox"/> 224 = 14" <input type="checkbox"/> 256 = 16" |
|---|--|

7. Option + Trim + Seat + O-Ring*

Option		Trim		Seat		O-Ring	
Type	Designator	Type	Designator	Type	Designator	Type	Designator
Fire Safety	A	Same material as Body	0	PTFE	0	NBR	0
Sampling Probe	B	SS316	1	R.PTFE+Glass	1	VITON	1
Chemical Injection	C	CF8M	2	R.PTFE+Carbon	2	EPDM	2
Locking Device	D	SS316L	3	PEEK	3	KALREZ	3
Anti Tamper Key	E	SS304	4	PCTFE	4	CR	4
Metal Seat	H	A105 + ENP	5	POM	5	SILICON	5
Gear Actuator	G	A105 + CR	6	DEVLON-V	6	NBR (AED)	6
Weld Overlay	M	MONEL 400	7	DELIN	7	VITON (AED)	7
Lower Temp.	LT	316 + HF	8	METAL	8	HNBR	8
Vent Flange	V	DUPLEX	9	NYLON 6	9	Kalrez (AED)	9
Norsok	N	Inconel625	I			E985	A
		SS 410	Y			Lip-Seal	L
		F44	A			E985	A

* No designator is required for standard configuration: Fire Safety (A), Trim is the same material as the body (0), PTFE Seat (0), and NBR O-ring (0)

3. Valve Series

Type	Designator	1st ISOLATE	2nd ISOLATE	VENT
SINGLE BLOCK TYPE	1	BALL	-	NEEDLE
	2			OS & Y
	3			BALL
	4	NEEDLE		NEEDLE
	5	OS & Y		OS & Y
	6			OS & Y
DOUBLE BLOCK TYPE	1	BALL	BALL	NEEDLE
	2			OS & Y
	3			BALL
	4	NEEDLE		NEEDLE
	5	OS & Y		NEEDLE
	6			OS & Y
	7	TR BALL		NEEDLE
	8			OS & Y
*A	FUGITIVE EMISSION CL-A			
*B	FUGITIVE EMISSION CL-B			

* Add designator "A" or "B" as a suffix to the Valve Series designator for Fugitive Emission.
(Example: SB11A1-R8A8-D111-AB)

6. Pressure Class

- | | |
|---|---|
| <ul style="list-style-type: none"> <input type="checkbox"/> A = CL150 <input type="checkbox"/> B = CL300 <input type="checkbox"/> C = CL600 <input type="checkbox"/> D = CL900 <input type="checkbox"/> E = CL1500 <input type="checkbox"/> F = CL2500 <input type="checkbox"/> S = CL800 | <ul style="list-style-type: none"> <input type="checkbox"/> G = 2000psi <input type="checkbox"/> H = 3000psi <input type="checkbox"/> I = 5000psi <input type="checkbox"/> J = 10000psi |
|---|---|

8. Body Material

- (Blank)** = SS316
- 304** = SS304
- 36L** = SS316L
- 34L** = SS304L
- 15** = A105
- LF2** = A350 LF2
- F51** = A182 F51
- M40** = MONEL 400
- AB** = AL BRONZE
- 625** = INCONEL 625

Monoflange Valves

Features

- ANSI B16.5 flanged inlet connections, sizes from 1/2" to 2", rated from Class 150 to 2,500.
- 1/2"-14 NPT(female) standard outlet.
- 1/4"-18 NPT(female) standard vent.
- Stainless steel as the standard body material. Optional materials include Super Duplex, Monel, Hastelloy, Inconel.
- Combined needle and OS & Y valves available.
- Raised face and ring type joint flange styles.
- One-piece forged construction flange as standard.
- Fire safe designed to meet BS 6755 Part 2 / API607 (Optional).
- Pressure boundary designs calculated to ASME VIII Div 1 and verified by testing.
- Heat code traceable material to EN 10204.3.1.
- Bubble tight shut off valve seats 17-4 PH tips standard.
- Colour coded functional valves.
- Locking and anti tamper devices for all valve types available (Optional).
- Permanent marked body with full order and specification details.

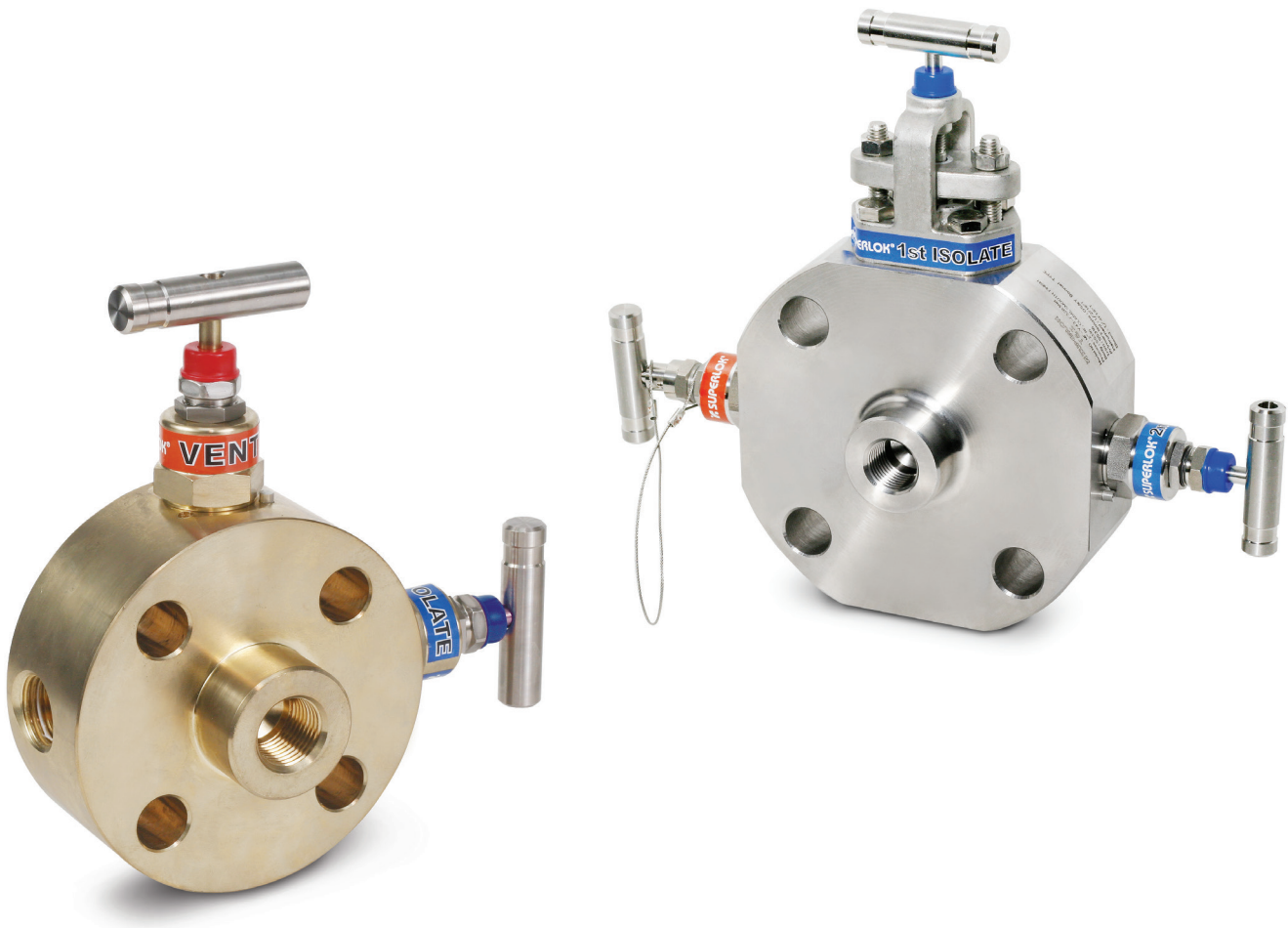
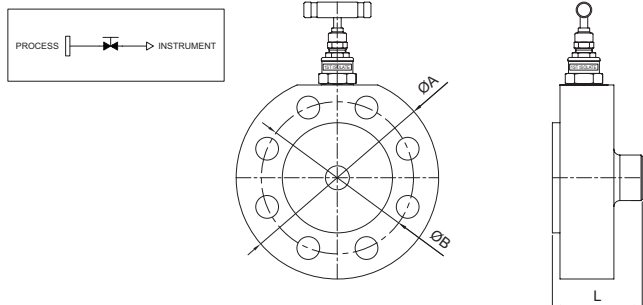
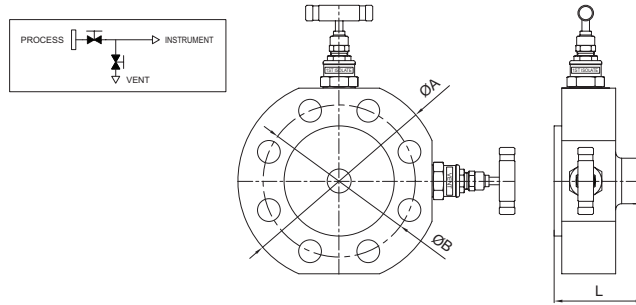

Table of Dimensions

MF1V1 Series



MF1V2 Series



MF1V3 Series

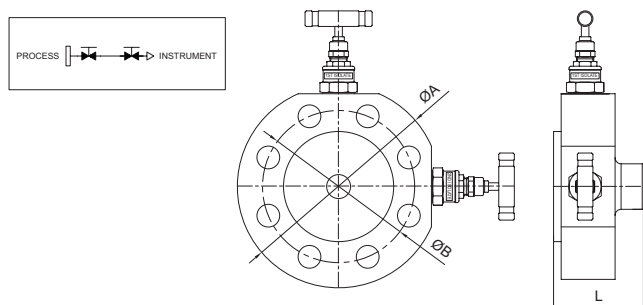

MF1V4 Series

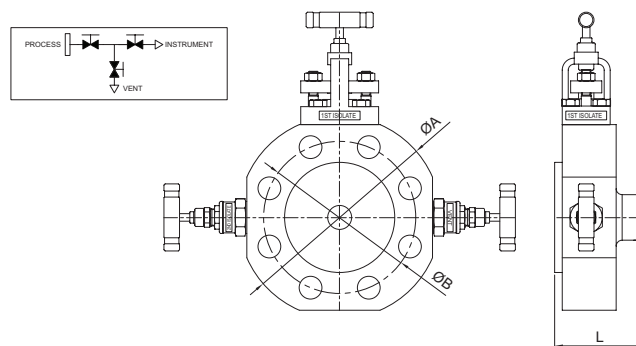

Size (inch)	Rating (lb)	Dimension			
		L(RF)	L(RTJ)	A	B
1/2 (DN15)	150	64	-	90	60.3
	300		68	95	
	600	95			
	900/1500	120		82.5	
	2500	135	88.9		
3/4 DN(20)	150	64	-	100	69.8
	300		68	115	
	600	115		82.5	
	900/1500	130		88.9	
	2500	140	95.2		
1 (DN25)	150	64	68	110	79.4
	300			125	
	600	68	125	88.9	
	900/1500	73	150		
	2500	73	160	108.0	
1-1/2 (DN40)	150	64	68	125	98.4
	300	69	69	155	
	600	73	73	155	114.3
	900/1500			180	
	2500	82	84	205	146.1
2 (DN50)	150	69	73	150	120.6
	300		75	165	
	600	73		165	127.0
	900/1500	82	84	215	

- Dimensions and Drawings are for reference only and are subject to change without prior notice.

- Unless otherwise specified, all dimensions are in millimeters.

- Sizes, pressure classes, and end connections not listed are available upon request.

Ordering Information

Example 1 :	MF1V41 - J8C8 - E 1 - AB
	<u>1</u> <u>2 3 2</u> <u>4 5</u> <u>6</u>
Example 2 :	MF1V11 - R8C8 - LF2
	<u>1</u> <u>2 3 2</u> <u>6</u>

1. Valve Type

	Designator		1st ISOLATE	2nd ISOLATE	VENT
<input type="checkbox"/> 1 = FLANGE x FNPT <input type="checkbox"/> 2 = FLANGE x FLANGE	V1	1	NEEDLE	-	-
		2	OS & Y		
	V2	1	NEEDLE	-	NEEDLE
		2	OS & Y		OS & Y
		3			
	V3	1	NEEDLE	NEEDLE	-
		2	OS & Y		
		3	OS & Y		
	V4	1	NEEDLE	NEEDLE	NEEDLE
		2	OS & Y		
		3			
		4			

2. Connection Size

- R = Raised Face
- J = Ring Type Joint Flange
- F = Flat Face
- AF = API 6B Type
- SA = SAE J518 Flange
- IS = ISO 6164 Flange
- JF = JIS Flange

+

- 8 = 1/2"
- 12 = 3/4"
- 16 = 1"
- 24 = 1-1/2"
- 32 = 2"
- 48 = 3"

3. Pressure Class

- A = CL150
- B = CL300
- C = CL600
- D = CL900
- E = CL1500
- F = CL2500

4. Option

- (Blank) = Fire Safety (Standard)
- D = Locking Device
- E = Anti Tamper Key
- F = Bolted Bonnet
- V = Vent Plug
- N = Norsok

5. Trim

- (Blank) = Same material as the body
- 1 = SS316
- 2 = CF8M
- 3 = SS316L
- 4 = SS304
- 5 = A105+ENP
- 6 = A105+CR
- 7 = MONEL 400
- 8 = 316+HF
- 9 = Duplex
- I = Inconel 625

6. Body Material

- (Blank) = SS316
- 15 = A105
- LF2 = A350 LF2
- F51 = A182 F51
- M40 = MONEL 400
- AB = AL BRONZE
- 625 = INCONEL 625

※ For special sizes and configurations, please consult BMT (SUPERLOK) sales representative.