

082 SERIES

High Pressure Reducing Regulators

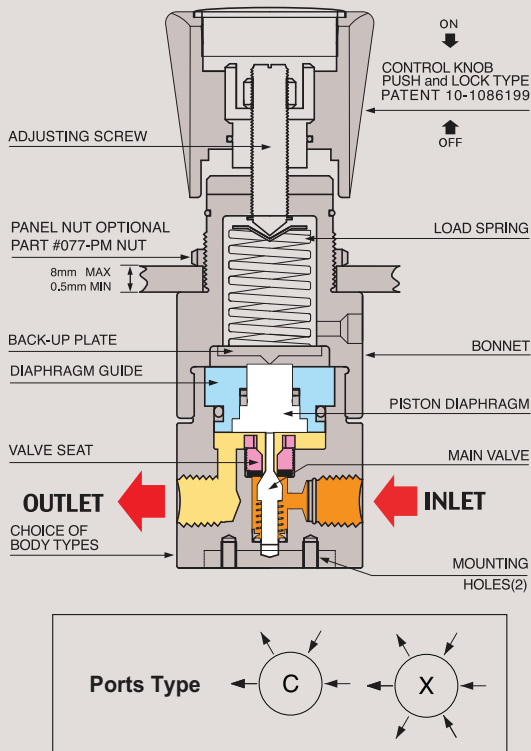

FUNCTIONAL SCHEMATIC



FLOW CHART

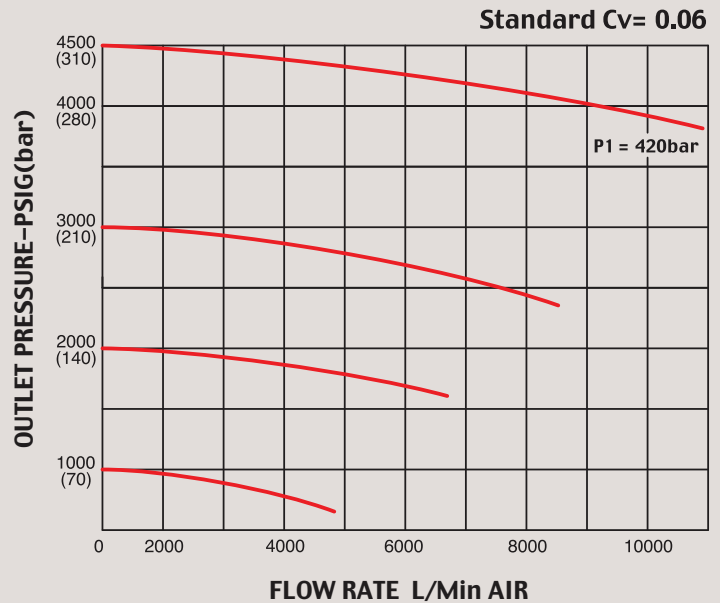

High Pressure NPT type (1/4")

082시리즈는 가스실린더 및 모든 고압가스를 안전하고 편리하게 사용할 수 있도록 개발된 고압가스 전용 레귤레이터 시리즈입니다.

- 당사가 독자 개발한 Piston-Diaphragm 방식을 채택하여 고압가스를 더욱 더 안전하고 편리하게 사용할 수 있습니다.
- 본체와 내부의 모든 부품이 Stainless Steel 316L로 이루어진 082S 모델은 각종 고순도 가스, 부식성 가스, 제약 및 실험실, 연구소 등에 폭 넓게 사용되며, 가스 및 액체 등에서 안심하고 사용할 수 있습니다.
- 입구 압력은 6000psig(420bar)이고 출구 압력은 최저 70psi(5bar) 부터 최대 4500psi(310bar)까지 사용 할 수 있는 NPT 1/4" type 4-Ports 전용 Regulator 입니다.
- 사용 중 가스라인이나 외부의 미세 진동 등으로 인하여 초기 압력 셋팅 값이 미세하게 변동하는 현상을 완전히 해결한 당사 Push and Lock 조절 손잡이 (당사 특허 #10-1086199)를 적용하여 사용하기에 더욱 편리합니다. 조절 손잡이를 누르면 (lock) 압력 셋팅 값이 변하는 것을 완전히 방지할 수 있고, 손잡이를 앞으로 당기면 (unlock) 자유롭게 원하는 압력으로 다시 셋팅 할 수 있습니다.

* 주의 : 크린라인이 아닌 일반 라인에 사용 할 경우 반드시 필터링(gas 7 μ m~15 μ m, water 15 μ m~80 μ m)을 하여야 하며, 그렇지 않을 경우 바로 고장의 원인이 됩니다. 모든 제품은 필터링하여 사용하면 A/S 비용 절감과 제품의 수명연장에 많은 도움이 됩니다.

Specifications

In/Outlet Port Size	1/4" FNPT / Gauge port: 1/4" NPT
Body	082S-0000-1S: Stainless Steel 316L 082B-0000-1S: Nickel Plated Brass
Bonnet	Nickel Plated Brass (Standard) / Stainless Steel (Option)
Diaphragm	Stainless Steel 316L
Main Valve	Stainless Steel 316L
Valve Spring	Stainless Steel 316L
Valve Seat	Teflon (Kel-F, Polyimide, etc.: optional)
Maximum Inlet Pressure	6,000psig (420bar)
Outlet Pressure Range	650(45bar), 1000(70bar), 2000(140bar), 3000(210bar), 4500psig(310bar)
Design Proof Pressure	150% of maximum rated
Leakage	to 2x10 ⁻⁸ atmcc/secHeliumavailable
Operating Temperature	-40°C to +70°C(-40°F to +160°F) (Standard) H1 option: up to +120°C (Optional) H2 option: up to +250°C (Optional)
Flow Capacity	Cv = 0.06 (Standard), 0.2 (Option)
Other Options	CGA, Pressure Gauge, etc.
Weight	Approx. 1.2kgs

REFERENCE

Contents in the catalogue including specifications, performance data, etc. can be changed without prior notice in the course of continuous upgrading and improvement of the products.
 사양서와 성능데이터 등 카다록에 있는 내용은 당사 제품의 지속적인 업그레이드 및 개선의 과정에서 사전 예고 없이 변경될 수 있습니다.

INSTALLATION DIMENSIONS
METRIC EQUIVALENTS ARE IN PARENTHESES

■ GAUGE PORT OPTIONS

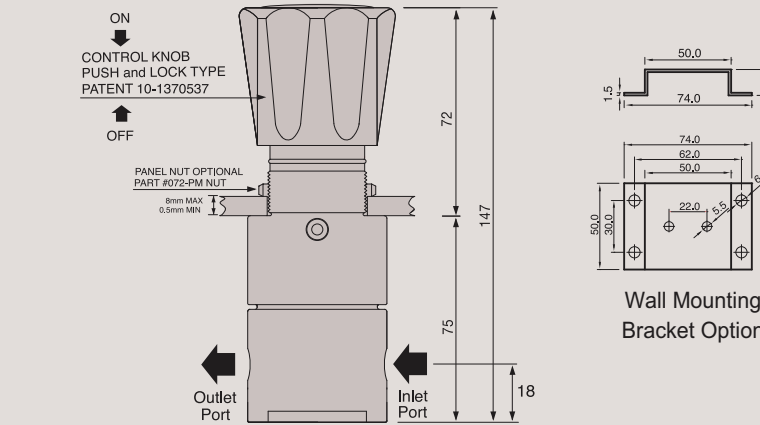
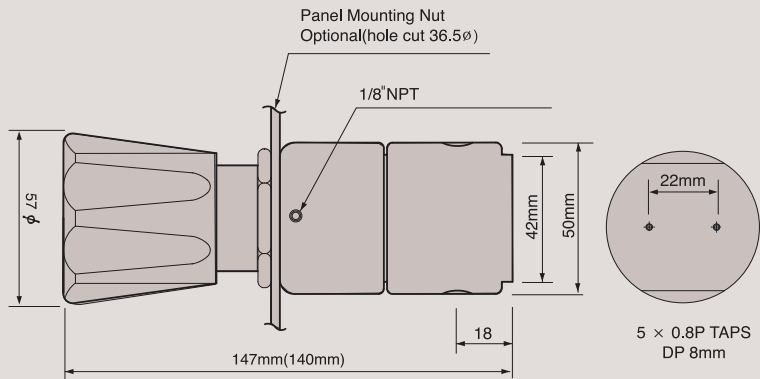
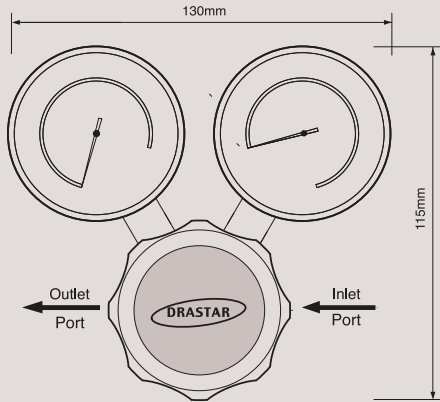
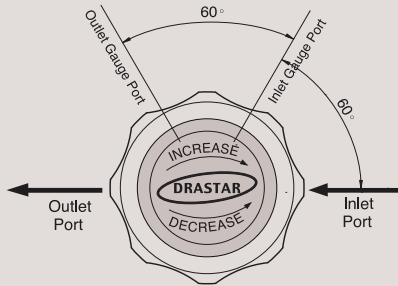

082 Series is a 1/4" NPT type single-stage high pressure reducing regulator designed to use for gas cylinder and all high pressure gases more easily and safely with "Piston-Diaphragm" which Drastar specially developed.

With DRASTAR's patented (patent 10-1086199) "push and lock type handle", you can operate it easily and stably; "locking" by pushing down the handle will prevent any slight change of pre-set pressure value, which could possibly be caused by any vibration from gas pipeline or ambient applications and the other way "unlocking" by pulling it back enables you to adjust the pressure value freely again.

Features & Applications

- 1/4" NPT type high pressure regulator
- Drastar's specially developed "piston-diaphragm" mounted
- Inlet pressure is 6000psi(420bar) and outlet pressures are 1000psig (70 bar) ~ 4500psig(310bar)
- Panel mounting nut or wall mounting bracket available as option • Design proof pressure: 150% of maximum rated
- Applicable for gas and liquid in the field of various high purity gases, corrosive gases, pharmaceutical line, research labs, etc. (082S model made of stainless steel 316L for its internals and body)

※ DRASTAR's all pressure regulators are assembled, cleaned, inspected, and packed in clean-room equipped with clean bench, helium detector, particle counter, ultrasonic cleaner, ultrapure water system, vacuum packaging machine, etc. through oxygen cleaning procedure in compliance with process and regulations indicated in CGA 4.1. and or ASTM G-93 and are free of any grease or oils.

※ **Caution:** Filtering (gas 7µm~15µm, water 15µm~80µm) is a MUST to use in the general gas application other than high purity gases. Otherwise, it may cause a failure to the regulators. It is strongly recommended to install filter for extension of life span and saving the maintenance expense

ORDERING INFORMATION

082 S - 1000 - 1S H - V - H1

BASIS SERIES NUMBER	BODY MATERIAL	OUTLET PRESSURE RANGE	FLOW CAPACITY	DIAPHRAGM MATERIAL	SELF VENTING	HIGH TEMPERATURE
Standard Inlet Pressure 6000psig (420 bar)	B = Brass S = Stainless Steel 316L	0650 = 5-650psi (0.4-45bar) 1000 = 10-1000psi (0.7-70bar) 2000 = 20-2000psi (1.5-140bar) 3000 = 30-3000psi (2.0-210bar) 4500 = 30-4500psi (3.0-310bar)	1 = 1/4" NPT S = Cv 0.06 Standard O = Cv 0.2 Optional	STS 316L Standard H = Hastelloy-C Optional	V = Self-Venting Optional	H1 = +120° C H2 = +250° C H3 = +320° C Optional

※ Note : 1) Outlet pressure 4500 model is not available with self-venting(V) 2) H1, H2, H3 option is not available for brass products.

082 SERIES PART LIST

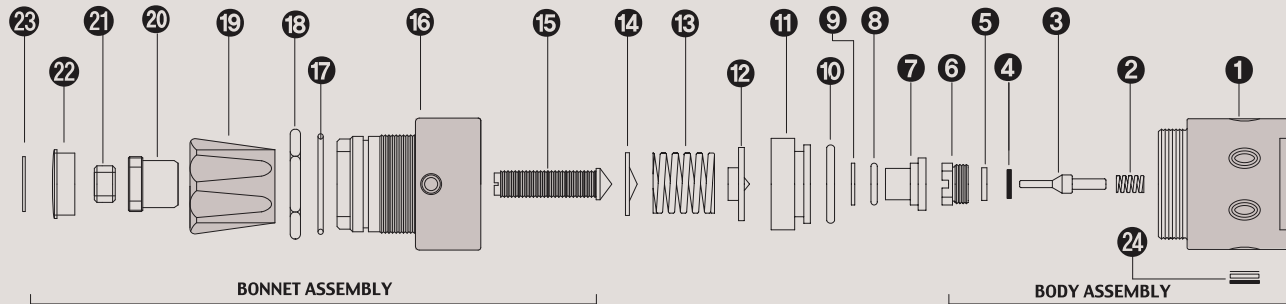

STANDARD MODEL SERIES

Item No.	Description	Part No.	Model Application
01	Body	082-02-01	02-01 Stainless Steel 316L / 02-02 Brass Body / 02-03 Monel
02	Valve Spring	082-04-01	04-01 STS 316L / 04-03 Hastelloy C-22 / 04-04 Monel
03	Main Valve	082-06-01	06-01 STS 316L / 06-03 Hastelloy C-275 / 04-04 Monel
04	Valve Seat	082-10-01	10-01 PFA / 10-05 Vespel / 10-06 Peek
05	Valve Seat Cartridge	082-08-01	All Model Same
06	Locking Screw	082-12-01	All Model Same
07	Piston Diaphragm	082-18-01	All Model Same
08	Piston Diaphragm O-ring	082-18-00	All Model Same
09	Diaphragm Teflon Ring	082-18-00	All Model Same
10	Diaphragm Guide O-ring	082-18-00	All Model Same
11	Piston Diaphragm Guide	082-20-01	20-01 Series Stainless steel 316L / 20-02 Brass
12	Spring Plate	082-30-01	All Model Same
13	Load Spring	082-38-01	38-08 1000psi / 38-09 2000psi / 38-10 3000psi / 38-11 4500psi
14	Pivot	082-40-01	All Model Same
15	Adjusting Screw	082-42-01	All Model Same
16	Bonnet	082-44-02	44-02 Brass / 44-01 Stainless steel 304 Bonnet Optional
17	Push & Lock O-Ring	082-46-01	All Model Same
18	Panel mount Nut	082-48-01	All Model Same
19	Control Knob	082-50-01	50-01 ABS / 50-04 Aluminum Control knob Optional)
20	Push & Lock Handle nut	082-52-01	All Model Same
21	Locking Nut	082-54-01	All Model Same
22	Name Cap	082-56-01	56-01 ABS
23	Name Cap Plate	082-58-07	58-08 1000psi / 58-09 2000psi / 58-10 3000psi / 58-11 4500psi
24	Filter Assembly	082-60-02	All Model Same