

# DC224-6

(224AH/6 Volt)

Industry Reference: GC2



**DEEP CYCLE SERIES**



## CONSTANT CURRENT DISCHARGE (Amps)

CUT OFF VOLTAGE V/cell	30M	45M	1H	2H	3H	5H	8H	10H	12H	20H	24H
1.75V	197.6	148	119.1	66.1	48.9	34.2	23.5	19.4	16.6	11.2	9.5

## RESERVE CAPACITY

@25 AMPS	@75 AMPS
441 Minutes	113 Minutes

## SPECIFICATIONS

Nominal Voltage		<b>6 Volt</b>
Rated Capacity (20 hour rate)		<b>224 AH</b>
<b>Dimensions</b>	Total Height (including terminals)	<b>272 mm (10.71")</b>
	Height	<b>245 mm (9.65")</b>
	Length	<b>260 mm (10.24")</b>
	Width	<b>180 mm (7.09")</b>
Weight		<b>29.8 kg (65.7 lbs)</b>

## CHARACTERISTICS

<b>Capacity</b> 77°F (25°C)	20 Hour Rate (11.2A to 5.25 Volts)	<b>224AH</b>
	10 Hour Rate (19.4A to 5.25 Volts)	<b>194AH</b>
	5 Hour Rate (35.9A to 5.1 Volts)	<b>179AH</b>
<b>Internal Resistance</b>	Full charged Battery 77°F (25°C)	<b>1.7m Ω</b>
<b>Capacity Affected by Temperature</b> (20 Hour Rate)	104°F (40°C)	<b>102%</b>
	77°F (25°C)	<b>100%</b>
	32°F (0°C)	<b>85%</b>
	5°F (-15°C)	<b>65%</b>
<b>Self-Discharge</b> 77°F(25°C)	Capacity after 3 month storage	<b>91%</b>
	Capacity after 6 month storage	<b>82%</b>
	Capacity after 12 month storage	<b>64%</b>
<b>Max. Discharge Current</b> 77°F (25°C)	2000A (5s)	
<b>Terminal Standard</b>	M8 with TP08 Brass AP	
<b>Charging Cycle</b> (Constant Voltage)	<b>Cycle</b>	Initial Charging Current $\leq 0.2 \times C20$ 7.25 V ~ 7.45 V/77°F (25°C)
	<b>Float</b>	6.8 V ~ 6.9 V/77°F (25°C)

## DISCHARGE CHARACTERISTICS

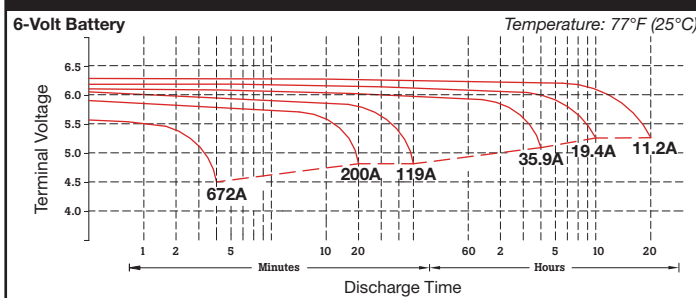

## SIZE & DETAILED ILLUSTRATION

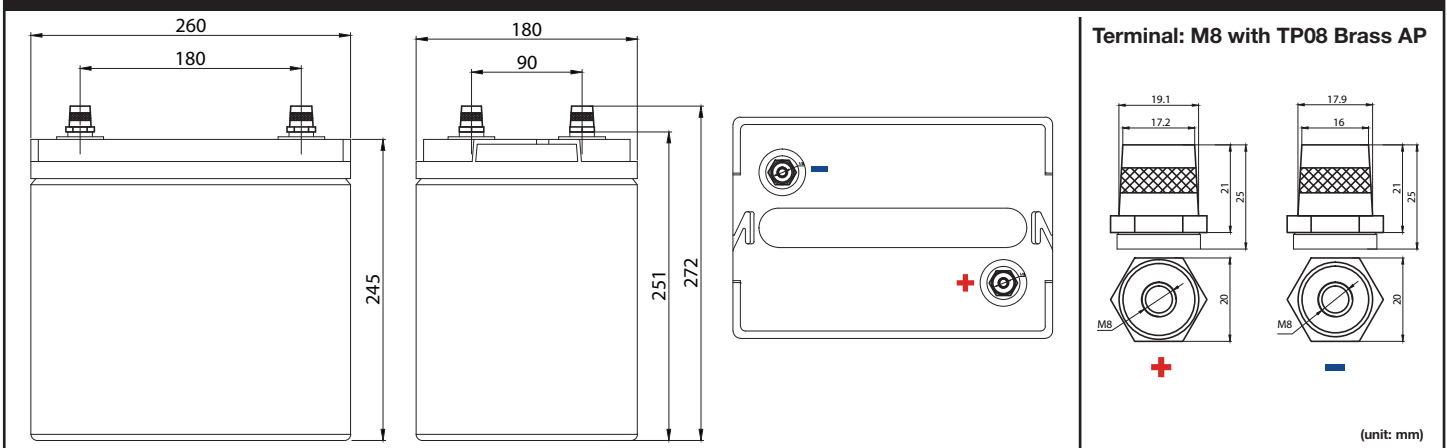

This information is generally descriptive only and is not intended to make or imply any representation, guarantee or warranty with respect to any cells and batteries. Cell and battery designs/specifications are subject to modifications without notice. Contact Fullriver for the latest information.