

ANSI-150LB Y-STRAINER

FEATURES:

- End flange dimensions: ASME B16.5
- Design: ASME B16.34
- Test: API 598
- Investment Casting Body

MATERIAL LIST

No.	Part Name	Material
1	Body	CF8 CF8M
2	Screen	SS304 SS316
3	Gasket	PTFE
4	Cap	CF8 CF8M
5	Gasket	PTFE
6	Stopper	CF8M
7	Spring Washers	SS304
8	Bonnet Bolt	SS304



TEST PRESSURE

Shell	By Water	ANSI-150
		450PSI 32kg/cm ²
Shell	By Air	85PSI
		6kg/cm ²

SCREEN SPECIFICATION

Size	Perforation
1/2"-11/4"	1.5MM
11/2"-12"	2MM

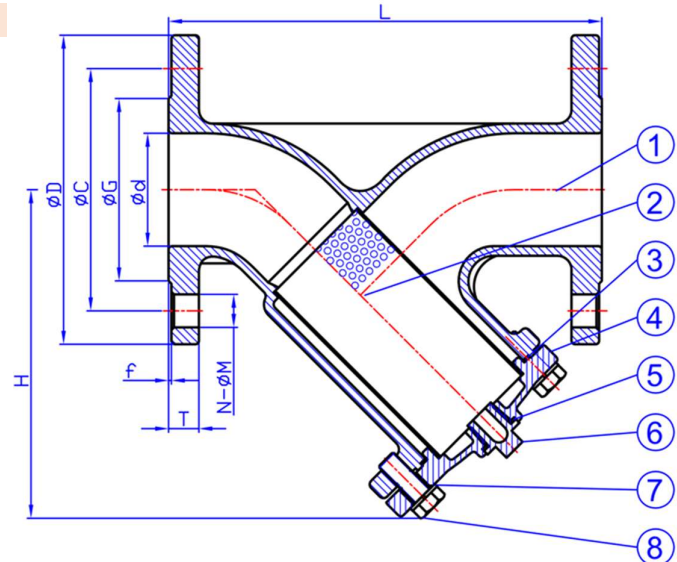

DIMENSIONS

Size	d	L	H	D	C	G	f	T	N- ØM
1/2"	15	15	120	85	89	60.5	35	1.6	11.1 4- Ø16
3/4"	20	20	140	87	98	70.0	43	1.6	11.1 4- Ø16
1"	25	25	150	114	108	79.5	51	1.6	11.1 4- Ø16
11/4"	32	32	180	114	117	89.5	64	1.6	12.7 4- Ø16
11/2"	40	40	190	135	127	98.5	73	1.6	14.3 4- Ø16
2"	50	50	210	155	152	120.5	92	1.6	15.9 4- Ø19
21/2"	65	65	250	189	178	139.5	105	1.6	17.5 4- Ø19
3"	80	80	280	200	190	152.5	127	1.6	19.1 4- Ø19
4"	100	100	340	232	229	190.5	157	1.6	23.9 8- Ø19
5"	125	125	380	274	254	216.5	186	1.6	23.9 8- Ø22
6"	150	150	420	326	279	241.5	216	1.6	25.4 8- Ø22
8"	200	200	500	397	343	298.5	270	1.6	28.6 8- Ø22
10"	250	250	730	512	406	362.0	324	1.6	30.2 12- Ø25
12"	300	300	850	562	483	432.0	381	1.6	31.8 12- Ø25