

# JIS-10K Y-STRAINER

## FEATURES:

- End flange dimensions: JIS B2220
- Design: ASME B16.34
- Test: JIS B2003
- Investment Casting Body

## MATERIAL LIST

No.	Part Name	Material
1	Body	CF8 CF8M
2	Screen	SS304 SS316
3	Gasket	PTFE
4	Cap	CF8 CF8M
5	Gasket	PTFE
6	Stopper	CF8M
7	Spring Washers	SS304
8	Bonnet Bolt	SS304



## TEST PRESSURE

Shell	By Water	JIS-10K 2.1 MPa 21.5 kg/cm <sup>2</sup>
	By Air	0.6 MPa 6kg/cm <sup>2</sup>

## SCREEN SPECIFICATION

Size	Perforation
1/2"-11/4"	1.5MM
11/2"-12"	2MM

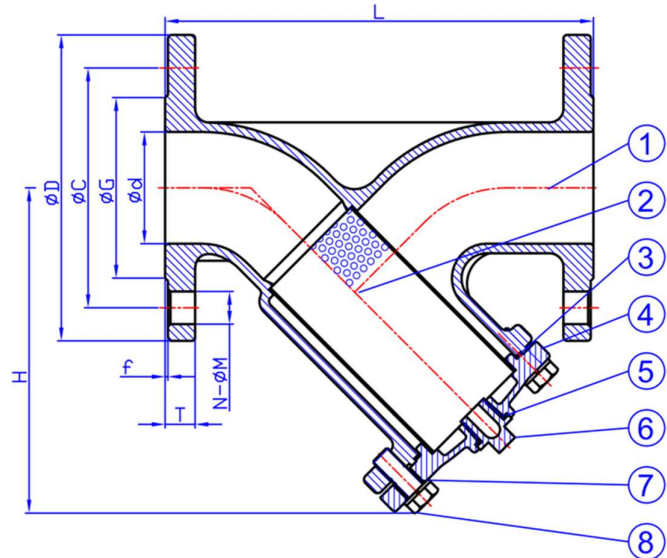

## DIMENSIONS

Size	d	L	H	D	C	G	f	T	N- ØM	
1/2"	15	15	120	85	95	70	51	1	12	4-Ø15
3/4"	20	20	140	87	100	75	56	1	14	4-Ø15
1"	25	25	150	114	125	90	67	1	14	4-Ø19
11/4"	32	32	180	114	135	100	76	2	16	4-Ø19
11/2"	40	40	190	135	140	105	81	2	16	4-Ø19
2"	50	50	210	155	155	120	96	2	16	4-Ø19
21/2"	65	65	250	189	175	140	116	2	18	4-Ø19
3"	80	80	280	200	185	150	126	2	18	8-Ø19
4"	100	100	340	232	210	175	151	2	18	8-Ø19
5"	125	125	380	274	250	210	182	2	20	8-Ø23
6"	150	150	420	326	280	240	212	2	22	8-Ø23
8"	200	200	500	397	330	290	262	2	22	12-Ø23
10"	250	250	730	512	400	355	324	2	24	12-Ø25
12"	300	300	850	562	445	400	368	3	24	16-Ø25