

SPECIAL EDITION



Electro Mechanical Automated System

A Clear Choice

Model DOS-2



24vdc Heavy Duty

Model DOS-3

Swing / Folding Gate Operator



Simple Unlocking System By Key

The manual release device has been designed to make operation really easy



Australia
TECHNOLOGY

www.ados.com.my



ElectroMechanical Automated System

A Clear Choice

AUTOMATED SYSTEM FOR SWING AND FOLDING GATE

- Can open either left, right or both panel
- Automatic dual speed adjustment
- Smooth & silent gate operation
- 24 hour backup power
- Manual operation
- 24vdc Heavy duty

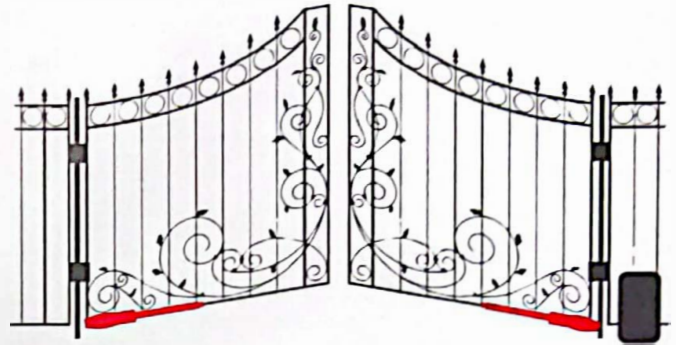

TECHNICAL SPECIFICATION

| | |
|---------------------------|--|
| Supply Power | : AC 220V, 60Hz/50Hz |
| Operating Voltage | : DC 24V for Normal Speed DC12 for Cushioning Speed |
| Max.Length of Gate | : 3.5 Meter per Wing |
| Safety Cluth | : Electronic Current Sensing |
| Electronic Controller | : Micro- Processor Base_d |
| Position Limit Device | : Electronic Fuzzy Logic |
| Driving Method | : Electro - Mechanical screw drive piston type |
| Back-up Battery | : 12 volt 7AH Rechargeable |
| Max. Gate Weight | : 350kg per Wing with Force Adjustable |
| Motor Power Supply | : 12 - 24V |
| Travel Time 90 (sec) | : 10 - 15sec |
| Working Temperature (C) | : 10°C to 50°C |
| Weight (KG) | : 2.9 KG |

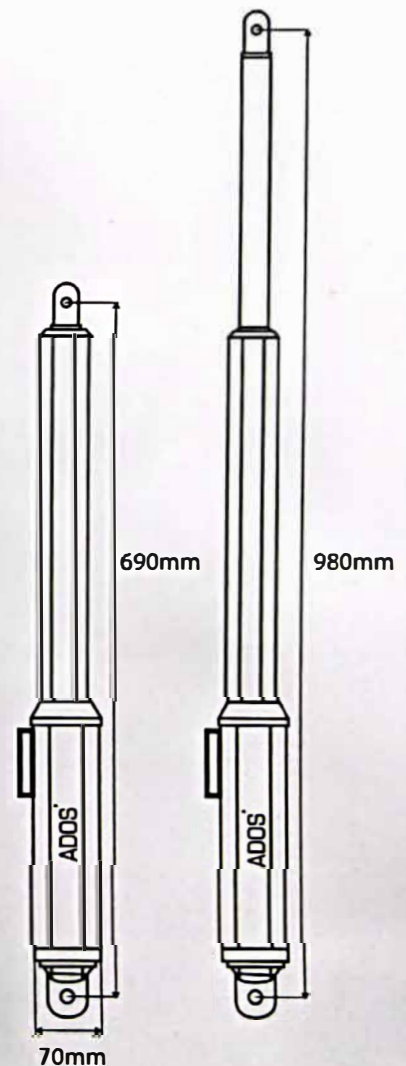

Battery Backup Systems



12 Months Warranty



Pro-Service



Best Choice

For Enquiries, Please Contact :



Australia
TECHNOLOGY