

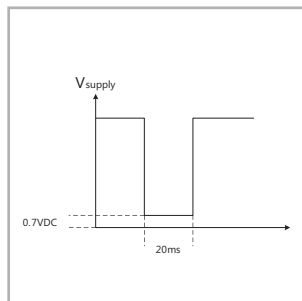

## CONTOIL®

Fuel oil meters  
DN 4...8

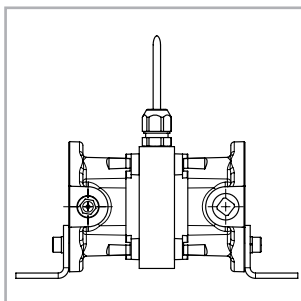
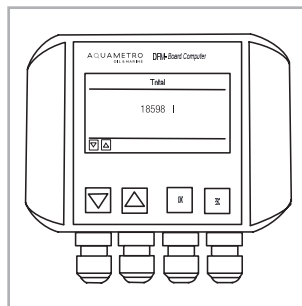
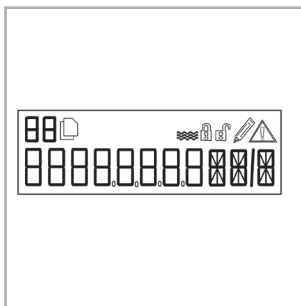

Fuel consumption measurement for trucks, buses, trains, construction and agricultural machinery, small boats and generators as well as for burners.

### Features

- Supports most used models of vehicles
- Proved and tested system
- Easy and accurate reading of engine fuel consumption
- No extra maintenance necessary
- Tamper-proof measurement

### Benefits

- Low installation costs
- Quick and easy installation
- Short down-time of vehicle
- Quick pay-back period

## Product range CONTOIL® DN 4...8 (12)

### Flow meters for direct fuel measurement

#### Hydraulic

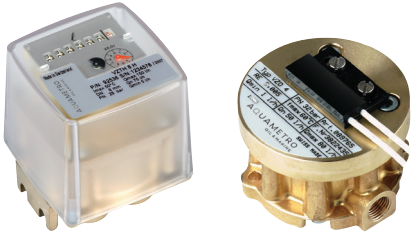

#### **VZO 4 Qmin / VZO 4 + 8 / VZO 4 + 8 OEM**

Hydraulic connections 1/8" and M14x1.5

Main characteristics:

- optimal flow range 50/135 l/h
- temperature ranges -30 to +80 °C
- nominal pressure PN 25 and 32 bar



#### **VZD/VZP 4 + 8**

Hydraulic connections 1/8" and M14x1.5

Main characteristics:

- optimal flow range 50/135 l/h
- temperature ranges -30 to +80 °C
- nominal pressure PN 25 and 32 bar

[Page 6](#)

### Flow meters for differential fuel measurement



#### **DFM 8D**

Hydraulic connections M14x1.5

Main characteristics:

- optimal flow range 200 l/h supply
- temperature ranges -30 to +80 °C
- nominal pressure PN 16 bar



#### **DFM 8EDM / DFM 8ECO / DFM 12ECO**

Hydraulic connections M14x1.5

Main characteristics:

- optimal flow range 200 l/h (400 l/h) supply
- temperature ranges -30 to +80 °C
- nominal pressure PN 16 bar

[Page 7](#)

## Electronic read out

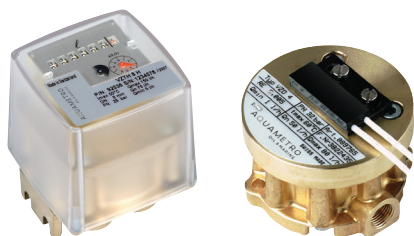

### VZO 4 + 8 RE / VZO 4 + 8 OEM

Output signals for:

- RE
- VZO OEM

**Page 9**



### VZD / VZP 4 + 8

Electronic display of:

- VZD

Output signals for:

- VZD / VZP

**Page 10**

## Calculation and data-sending to remote

### Board Computer



### DFM BC

Suitable for all CONTOIL® DFM flow meters and other manufacturers' flow meters.

Main characteristics:

- Total, trip, current consumption, info, service (password-protected)
- Configurable input-pulse value (0.1 ml to 9.9 litre)

**Page 14**

## Content

<b>Introduction</b>	<b>4</b>
<b>Operating principle</b>	<b>5</b>
<b>Technical specifications</b>	<b>6</b>
<b>Project planning notes</b>	<b>18</b>
<b>How to obtain an optimal measurement</b>	<b>20</b>
<b>CONTOIL® meter with CE approval</b>	<b>22</b>
<b>Warranty, safety instructions</b>	<b>23</b>

## Introduction

Thank you for your decision to work with Aquametro Oil & Marine AG Fuel Performance Products. This manual describes the installation, commissioning and use of Aquametro's CONTOIL® consumption measurement products. For additional information please contact your local sales agent at: [www.aquametro-oil-marine.com](http://www.aquametro-oil-marine.com).

### Liability Disclaimer

The manufacturer cannot monitor the compliance to this manual as well as the conditions and methods during the installation, operation, usage and maintenance of the system regulator.

Improper installation can cause damages and endanger people. Therefore, we assume no responsibility and liability for losses, damages or costs that result due to incorrect installation, improper operation, usage and maintenance or in any manner associated therewith. Similarly, we assume no responsibility for patent right or other right infringements of third parties caused by usage of this system regulator.

The manufacturer reserves the right, without prior notification, to make modifications concerning the product, technical data or installation and operating manual.

### Safety precautions

CONTOIL® consumption measurement products must only be used for their intended purpose and comply with local and international safety regulations. All documentation is to be followed exactly. None of the information stated here or elsewhere releases planners, installers and operators from their own careful and comprehensive assessment of the respective plant configuration in terms of functional capability and operational safety.

Local applicable working regulations must be complied with, during all work on the plant and/or ship.

All safety-, installation- and operation instruction as described in this manual must be followed.

Sensors are sensitive measuring instruments and should be treated carefully.

# Operating principle

## Function

CONTOIL® flow meters work on the volumetric principle of rotary piston meters (positive displacement meters). The main features of this measuring principle are large measuring ranges, high accuracy, suitability for high viscosities and independence from power supply; flow disturbances do not influence proper operation.

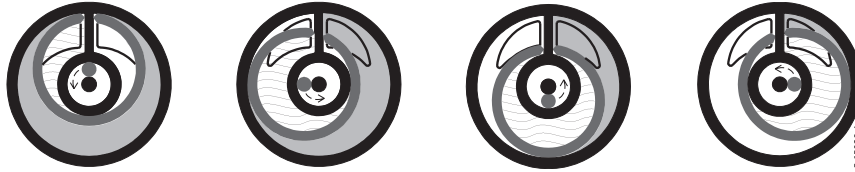

Leading manufacturers of oil burners and operators of heating systems, ships or diesel engines rely on CONTOIL® fuel oil meters - and with good reasons.

## The advantages of CONTOIL® fuel oil meters - your benefits

- Optimal solution for every application
- Can be mounted on the pressure or suction side of a pump
- Space-saving installation, because no straight inlet/outlet sections are required
- Flexible mounting of the meter in horizontal, vertical or inclined positions
- Accurate measurement result, since the reading is independent of the temperature and viscosity of the fluid
- Minimum failure costs due to simple function monitoring, rapid fault analysis and the possibility of simple repairs on site

## Areas of application

- To measure heating fuel consumption by oil burners (for example, in heating boilers, industrial furnaces, tar processing plants)
- Consumption monitoring and optimisation (ships, generators, etc)
- Flow measurement for mineral oils
- Optional remote processing and integration into superior systems
- Manual dosing / batching

## Fuel types

- Fluids according to ISO 8217-2010
- Heating fuel extra light/light

## Technical specifications

### Technical data CONTOIL® VZO 4 + 8 Hydraulic



Hydraulic			VZO 4	VZO 4 Qmin	VZOA 4 CE	VZO 4 OEM
<b>Nominal diameter</b>		<b>DN mm</b>	<b>4</b>	<b>4</b>	<b>4</b>	<b>4</b>
		inch	1/8	1/8	1/8	1/8
Hydraulic connection		G	1/8"	1/8"	1/8"	1/8"
Nominal pressure	PN	bar	25	25	25	25
Max. medium temperature	Tmax	°C	-30...+80	-30...+80	-10...+50	-30...+80
Max. storage temperature		°C	-40...+85	-40...+85	-25...+85	-40...+85
Protection class	IP		50	50	50	65
Maximum flow rate	Qmax	l/h	80	40	20	80
<b>Continuous flow rate</b>	<b>Qcont</b>	<b>l/h</b>	<b>50</b>	<b>25</b>	<b>20</b>	<b>50</b>
Minimum flow rate	Qmin	l/h	1	0.5	1	1
Approx. starting flow rate		l/h	0.4	0.3	-	0.4
Max. permissible error of actual value			<±1.0 % <sup>1)</sup>	<±1.0 % <sup>1)</sup>	<±0.5 %	<±1.0 % <sup>1)</sup>
Repeatability			<±0.2 %			
Measuring chamber volume		cm <sup>3</sup>	5	5	5	5
Fuel			diesel and low viscosity fuels			
Max. viscosity		cSt	6	6	6	6
Safety filter mesh size		mm	0.125	0.125	0.08	-
Weight		kg	0.65	0.65	0.65	0.65
Housing finish			brass gold color			

Hydraulic			VZO 8	VZO 8 CE	VZO 8 OEM
<b>Nominal diameter</b>		<b>DN mm</b>	<b>8</b>	<b>8</b>	<b>8</b>
		inch	1/4	1/4	1/4
Hydraulic connection		G	1/4"	1/4"	M14x1.5
Nominal pressure	PN	bar	25	25	25
Max. medium temperature	Tmax	°C	-30...+80	-10...+50	-30...+80
Max. storage temperature		°C	-40...+85	-25...+85	-40...+85
Protection class	IP		50	50	65
Maximum flow rate	Qmax	l/h	200	140	200
<b>Continuous flow rate</b>	<b>Qcont</b>	<b>l/h</b>	<b>135</b>	<b>140</b>	<b>135</b>
Minimum flow rate	Qmin	l/h	4	14	4
Approx. starting flow rate		l/h	1.6	-	1.6
Max. permissible error of actual value			<±1.0 % <sup>2)</sup>	<±0.3 %	<±1.0 % <sup>2)</sup>
Repeatability			<±0.2 %		
Measuring chamber volume		cm <sup>3</sup>	12.44	12.44	12.44
Fuel			diesel and low viscosity fuels		
Max. viscosity		cSt	6	6	6
Safety filter mesh size		mm	0.15	0.1	0.15
Weight		kg	0.75	0.75	0.75
Housing finish			brass gold color		

<sup>1)</sup> 0.5...1 l/h ±5 %; 1...2 l/h ±2.5 %

<sup>2)</sup> 4...5 l/h ±2 %

## Technical data CONTOIL® VZD/VZP 4 + 8 Hydraulic



Hydraulic			VZP 4	VZD 4	VZDA 4 CE
<b>Nominal diameter</b>		<b>DN mm</b>	<b>4</b>	<b>4</b>	<b>4</b>
		inch	1/8	1/8	1/8
Hydraulic connection		G	1/8"	1/8"	1/8"
Nominal pressure	PN	bar	25	25	25
Max. medium temperature	Tmax	°C	-30...+80	-30...+80	-10...+50
Max. env. temperature display <sup>3)</sup>		°C	-	-20...+60	-20...+60
Max. storage temperature		°C	-40...+85	-40...+85	-40...+85
Protection class	IP		66	66	66
Maximum flow rate	Qmax	l/h	80	80	20
<b>Continuous flow rate</b>	<b>Qcont</b>	<b>l/h</b>	<b>50</b>	<b>50</b>	<b>20</b>
Minimum flow rate	Qmin	l/h	1	1	1
Approx. starting flow rate		l/h	0.4	0.4	-
Max. permissible error of actual value			<±1.0 % <sup>1)</sup>	<±1.0 % <sup>1)</sup>	<±0.5 %
Repeatability			<±0.2 %		
Measuring chamber volume		cm <sup>3</sup>	5	5	5
Fuel			diesel and low viscosity fuels		
Max. viscosity		cSt	6	6	6
Safety filter mesh size		mm	0.125	0.125	0.125
Weight		kg	0.65	0.65	0.65
Housing finish			brass gold color		

Hydraulic			VZP 8	VZD 8	VZD 8 CE
<b>Nominal diameter</b>		<b>DN mm</b>	<b>8</b>	<b>8</b>	<b>8</b>
		inch	1/4	1/4	1/4
Hydraulic connection		G	M14x1.5	M14x1.5	M14x1.5
Nominal pressure	PN	bar	25	25	25
Max. medium temperature	Tmax	°C	-30...+80	-30...+80	-10...+50
Max. env. temperature display <sup>3)</sup>		°C	-	-20...+60	-20...+60
Max. storage temperature		°C	-40...+85	-40...+85	-40...+85
Protection class	IP		66	66	66
Maximum flow rate	Qmax	l/h	200	200	140
<b>Continuous flow rate</b>	<b>Qcont</b>	<b>l/h</b>	<b>135</b>	<b>135</b>	<b>140</b>
Minimum flow rate	Qmin	l/h	4	4	14
Approx. starting flow rate		l/h	1.6	1.6	-
Max. permissible error of actual value			<±1.0 % <sup>2)</sup>	<±1.0 % <sup>2)</sup>	<±0.3 %
Repeatability			<±0.2 %		
Measuring chamber volume		cm <sup>3</sup>	12.44	12.44	12.44
Fuel			diesel and low viscosity fuels		
Max. viscosity		cSt	6	6	6
Safety filter mesh size		mm	0.15	0.15	0.15
Weight		kg	0.65	0.75	0.75
Housing finish			brass gold color		

<sup>1)</sup> 0.5...1 l/h ±5 %; 1...2 l/h ±2.5 %

<sup>2)</sup> 4...5 l/h ±2 %

<sup>3)</sup> If the device is used below or above stated temperature rating, the LCD can react slower and life time can be shortened.

## Technical data CONTOIL® DFM 8 + 12 Hydraulic

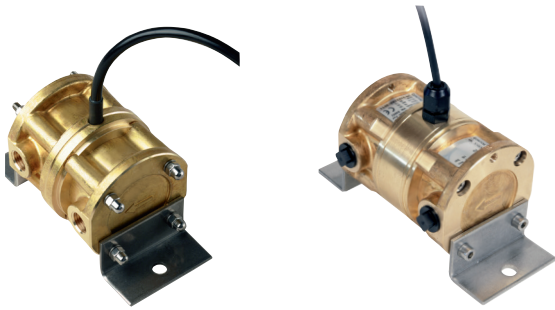

Hydraulic			DFM 8 D	DFM 8 ECO	DFM 8 EDM	DFM 12 ECO
<b>Nominal diameter</b>		<b>DN mm</b>	<b>8</b>	<b>8</b>	<b>8</b>	<b>12</b>
		inch	1/4	1/4	1/4	1/4
Hydraulic connection		G	M14x1.5	M14x1.5	M14x1.5	M14x1.5
Nominal pressure	PN	bar	16	16	16	16
Max. medium temperature	Tmax	°C	-30...+80	-30...+80	-30...+80	-30...+80
Max. storage temperature		°C	-40...+80 (short period -40...+125)			
Protection class	IP		66	66	66	66
Maximum flow rate	Qmax	l/h	260	260	260	600
<b>Continuous flow rate</b>	<b>Qcont</b>	<b>l/h</b>	<b>200</b>	<b>200</b>	<b>200</b>	<b>400</b>
Minimum flow rate	Qmin	l/h	10	10	10	10
Approx. starting flow rate		l/h	0.4	0.4	0.4	0.4
Max. permissible error of actual value			<±1.0 % <sup>1)</sup>			
Repeatability			<±0.2 %			
Measuring chamber volume		cm <sup>3</sup>	12.44	12.44	12.44	12.44
Fuel			diesel and low viscosity fuels			
Max. viscosity		cSt	6	6	6	6
Safety filter mesh size		mm	-	-	-	0.15
Weight		kg	0.65	0.65	0.65	0.65
Housing finish			brass gold color			

<sup>1)</sup> 4...5 l/h ±2 %



## Technical data CONTOIL® VZO 4 + 8 Electrical and output specifications

Electronic		VZO 4	VZO 8	VZO 4 OEM	VZO 8 OEM
Reed pulser					
RE 1	l/pulse	-	■	-	-
RE 0.1	l/pulse	■	-	-	-
RE 0.00125	l/pulse	■	-	-	-
RE 0.00311	l/pulse	-	■	-	-
Pulse frequency					
RE 0.00125	at Qmax	Hz	17.777	-	-
	at Qmin	Hz	0.222	-	-
RE 0.00311	at Qmax	Hz	-	17.864	-
	at Qmin	Hz	-	0.357	-
Reed pulser RE	l/pulse	-	-	0.005	0.01244
Pulse frequency RE	at Qmax	Hz	-	-	4.444
	at Qmin	Hz	-	-	0.056

Electronic CONTOIL® VZO 4 + 8	RE pulser
Switching element	Reed switch with dry contact (inert gas)
Switching voltage	Max. 48 VAC/DC, protection class III (SELV)
Switching current	Max. 50 mA
Quiescent current	Open contact
Switching power	Max. 2 W
ON-time	VZO 4-RE 0.00125: 30...70 % (17...39 ms at 80 l/h) VZO 4-RE 0.1: 40...60 % VZO 8-RE 0.00311: 30...70 % (17...39 ms at 200 l/h) VZO 8-RE 1: 40...60 %
Ambient temperature	-10...+60 °C
Protection class	IP 50 (IEC 60529) against harmful dust deposits Option: IP 54 additional against splashing water
Connections	On plug connector with cable 3.5 - 5 mm Ø

Electronic CONTOIL® VZO 4 + 8 OEM	RE pulser
Switching element	Reed switch with dry contact (inert gas)
Switching voltage	Max. 230 VAC/DC
Switching current	Max. 50 mA
Quiescent current	Open contact
Switching power	Max. 3 VA
ON-time	40...55 %
Ambient temperature	-10...+60 °C
Protection class	IP 65 (IEC 60529) against dust and water jets
Connections	Cable cross section 2 x 0.5 mm <sup>2</sup> , length 480 mm

### Safety note

When connecting the Reed pulser to a low-voltage power source (50...250 VAC/DC), the specialist installing the equipment is responsible for ensuring that all local regulations are observed (e.g. regulations for electrical installations, personnel safety).

Avoid disturbance of electromagnetic fields.

## Technical data CONTOIL® VZD/VZP 4 + 8 Electrical and output specifications

Electronic		VZP 4	VZD 4	VZD 4 CE
Pulse value (HI-Res)	I/pulse	0.005	0.005	0.005
Pulse value (Param)	I/pulse	-	0.150	0.150
Pulse width (HI-Res)	ms	20	20	20
Pulse width (Param)	ms	-	1'000	1'000
Current load (open drain output) max.	mA	50	50	50
Output operational voltage max.	VDC	48	48	48
Output dropout voltage		max. 2 VDC at 50 mA		
Power supply	VDC	12...24	12...24	12...24
Amplitude range		equal to power supply		

Electronic		VZP 8	VZD 8	VZD 8 CE
Pulse value (HI-Res)	I/pulse	0.01244	0.01244	0.01244
Pulse value (Param)	I/pulse	-	0.150	0.150
Pulse width (HI-Res)	ms	20	20	20
Pulse width (Param)	ms	-	1'000	1'000
Current load (open drain output) max.	mA	50	50	50
Output operational voltage max.	VDC	48	48	48
Output dropout voltage		max. 2 VDC at 50 mA		
Power supply	VDC	12...24	12...24	12...24
Amplitude range		equal to power supply		

CONTOIL® VZP 4/8

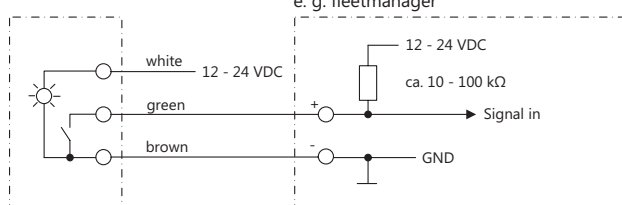

Output signal specification

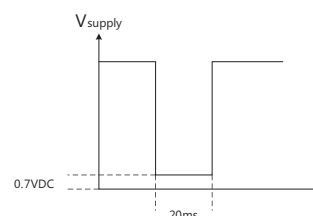

Remote-Device  
e. g. fleetmanager

CONTOIL® VZD 4/8

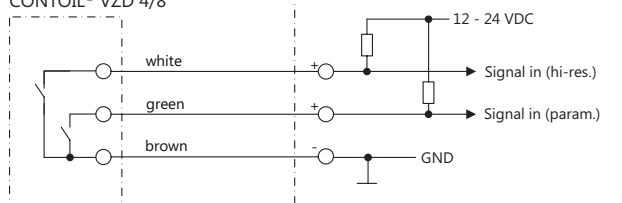

### Short view of the menu



#### Main menu

- Total, trip, current consumption
- Info, service
- Logger data, error data, display test

#### Info/service menu

- Idle/working mode, operation hours, unit
- Battery capacity, fuel temperature, RESET mode
- Correction factor, password
- Current CO<sub>2</sub> emission, total CO<sub>2</sub> emission
- Min. flow rate, max. flow rate
- Date, time

The complete menu is shown in the Operating Manual.

## Technical data CONTOIL® DFM 8 + 12 Electrical and output specifications

Electronic		DFM 8 D	DFM 8 ECO	DFM 8 EDM	DFM 12 ECO
Pulse value	I/pulse	0.01244	0.01244	0.01244	0.01244
Frequency	Hz	15	7	7	<14
Pulse width	ms	20	20	20	20...40
Current load (open drain output) max.	mA	10	10	10	<8
Power supply	VDC	12...24	12...24	12...24	12...24
Amplitude range		equal to power supply			

### CONTOIL® DFM 8 D Pulse specification; passive pulse

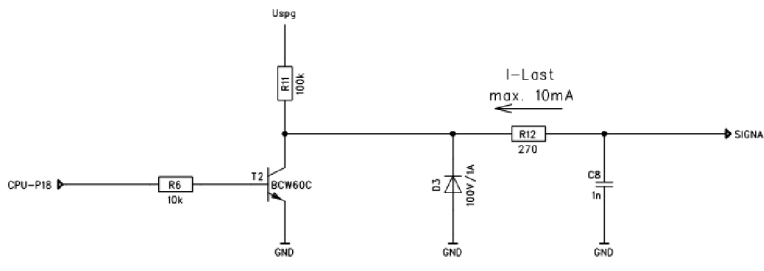

#### Output Signal Specification

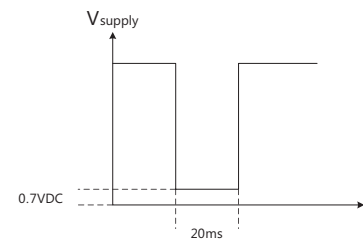

### CONTOIL® DFM 8 EDM Pulse specification; passive pulse

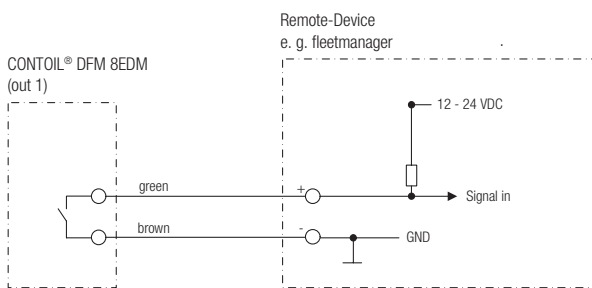

Whenever a pulse is generated, the electronic switch at the DFM 8EDM will be closed and the incoming 12-24VDC will be redirected to the external device.

#### TTL-Pulse

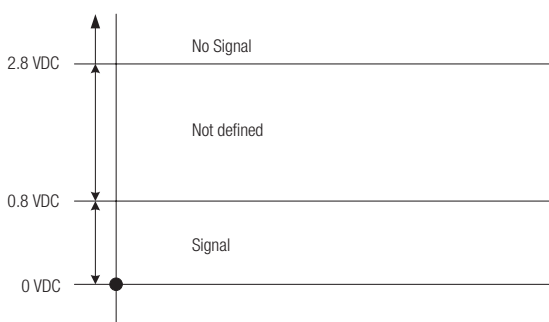

Below 0.8 VDC = pulse (logic 0)  
Between 0.8 – 2.8 VDC is not defined  
Over 2.8 VDC = no pulse (logic 1)

### CONTOIL® DFM 8 + 12 ECO Pulse specification; passive pulse

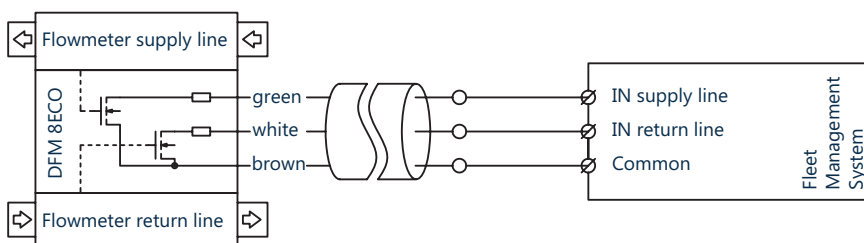

Whenever a pulse is generated, the electronic switch at the DFM 8ECO will be closed and the incoming 12-24VDC will be redirected to the external device.

## CONTOIL® DFM BC



Device		
Registration	l	100.000.000
Input (flow meter connections), adjustable from 0.1 ml to 9999.9 ml		2
Output (for remote device), adjustable from 0.1 ml to 9999.9 ml		1
Max. environmental temperature	°C	-10...+70
Data storage		EEPROM
Online Status of the connected flow meters		Yes
Protection class	IP	66

Electrical specifications		
Max. frequency of input-pulse	Hz	25
Cable lengths	m	7.5
Power supply	VDC	12...24
Power supply cable	mm <sup>2</sup>	2 x 0.75
Current load max.	mA	15
Pulse width min. (pulse in/pulse out; open drain output)	ms	20
Output operational voltage max.	VDC	48

- Safety; tested for vibration, shock and electrical emission and immission (vehicle industry standards)
- Diesel fuel, domestic fuel oil, engine oil (viscosity max. 6 cSt)
- 3 graphic display
- 4 navigations keys

## Dimensional drawings

(all dimensions in mm)

### CONTOIL® VZO 4 + 8

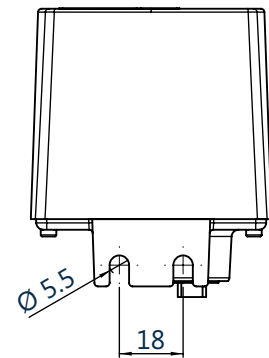
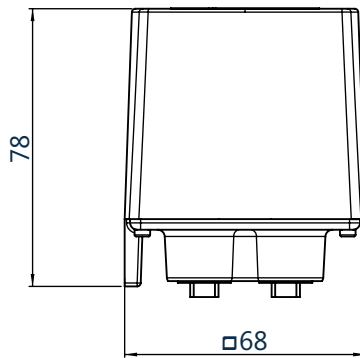
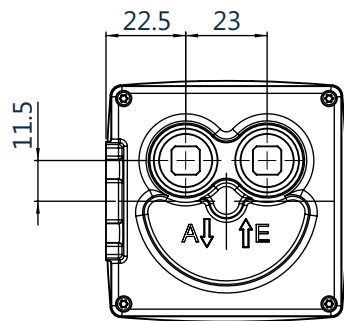

### CONTOIL® VZO 4 + 8 RE

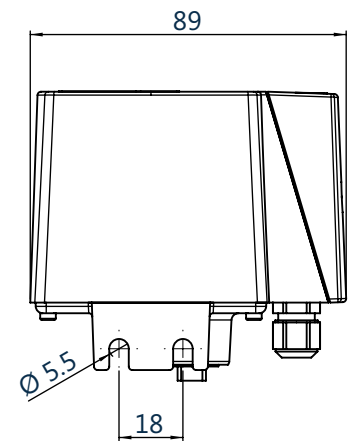
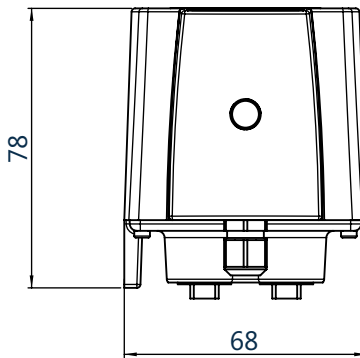
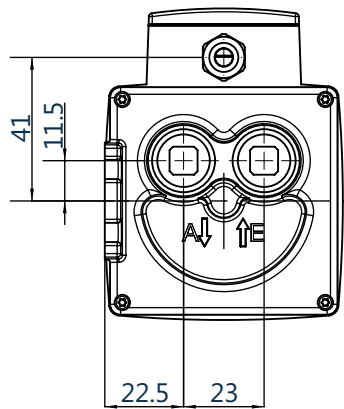

**CONTOIL® VZO 4 OEM**

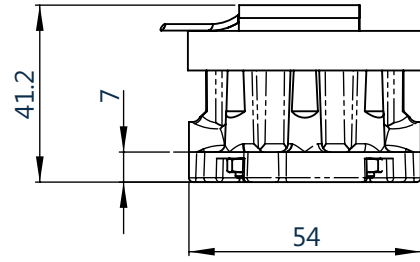
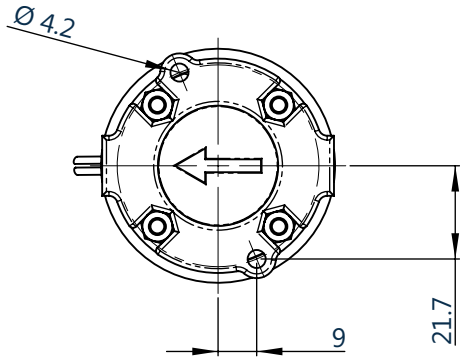

**CONTOIL® VZO 8 OEM**

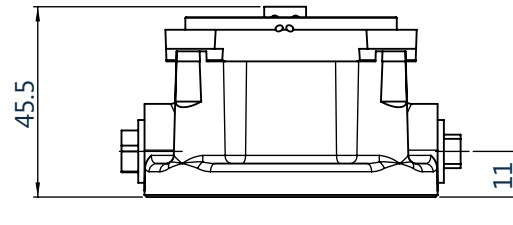
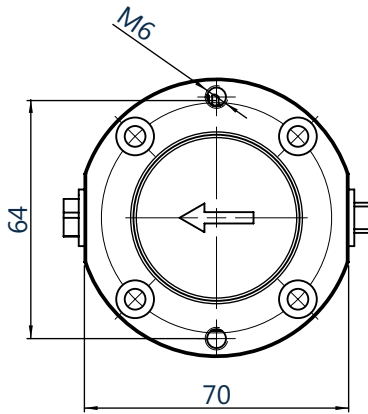

**CONTOIL® VZD/VZP 4**

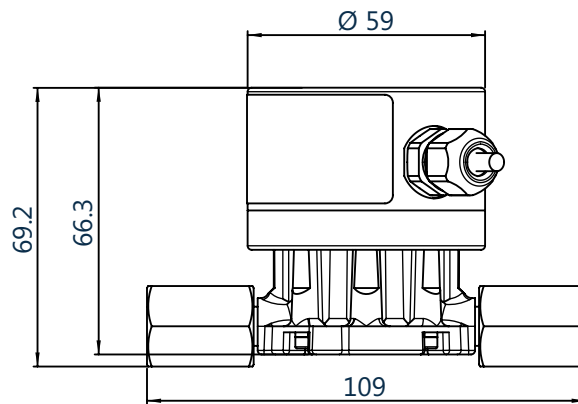
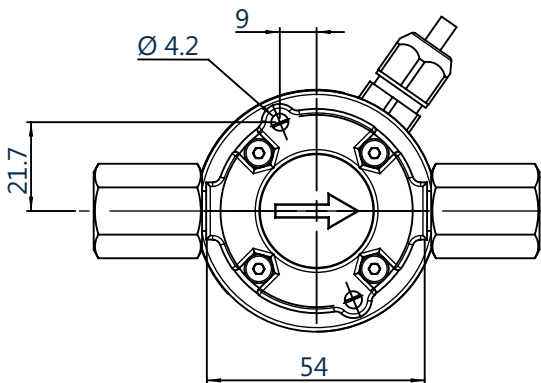

**CONTOIL® VZD/VZP 8**

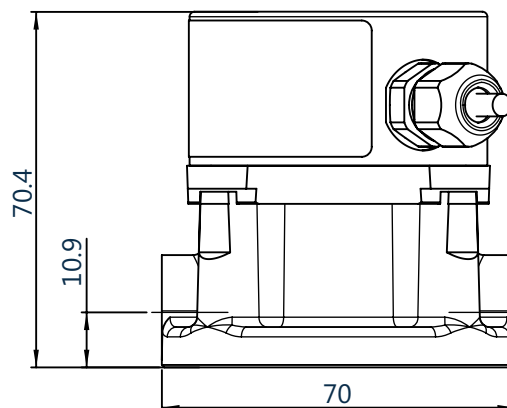
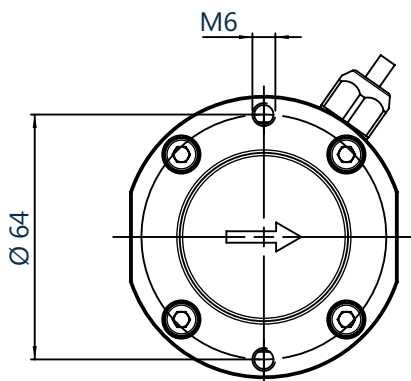

**CONTOIL® DFM 8D / DFM 8EDM**

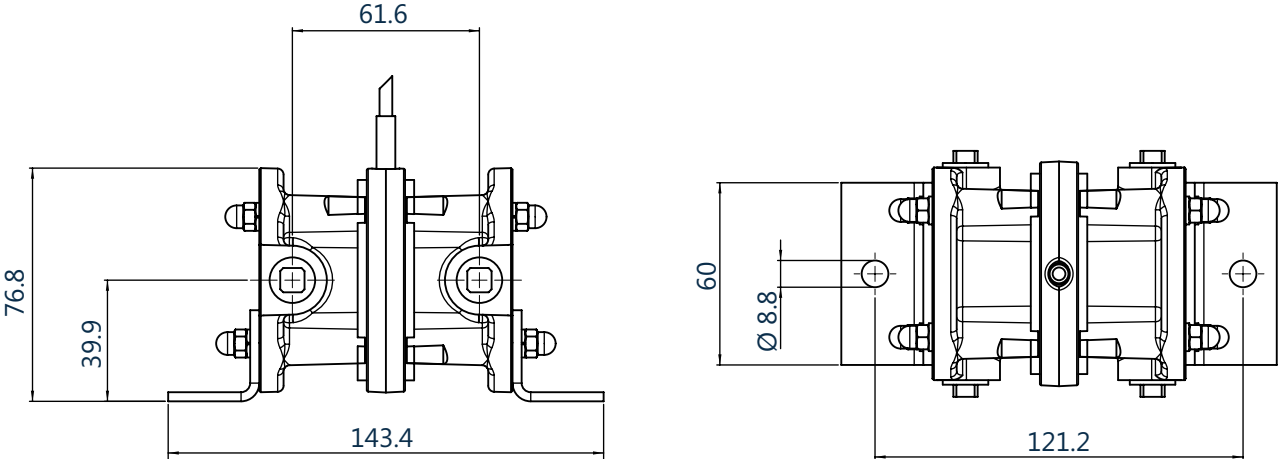

**CONTOIL® DFM 8ECO / DFM 12ECO**

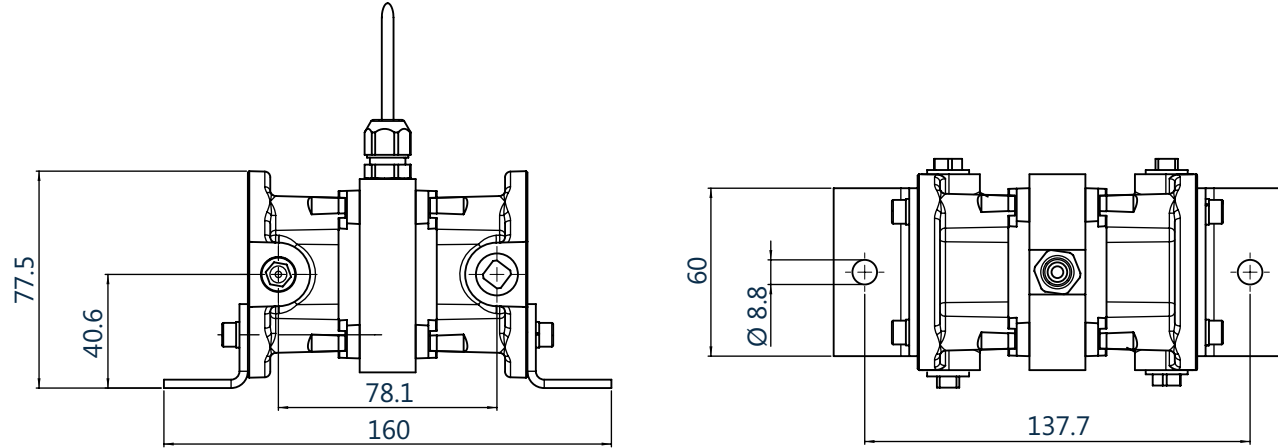

**CONTOIL® DFM-BC**

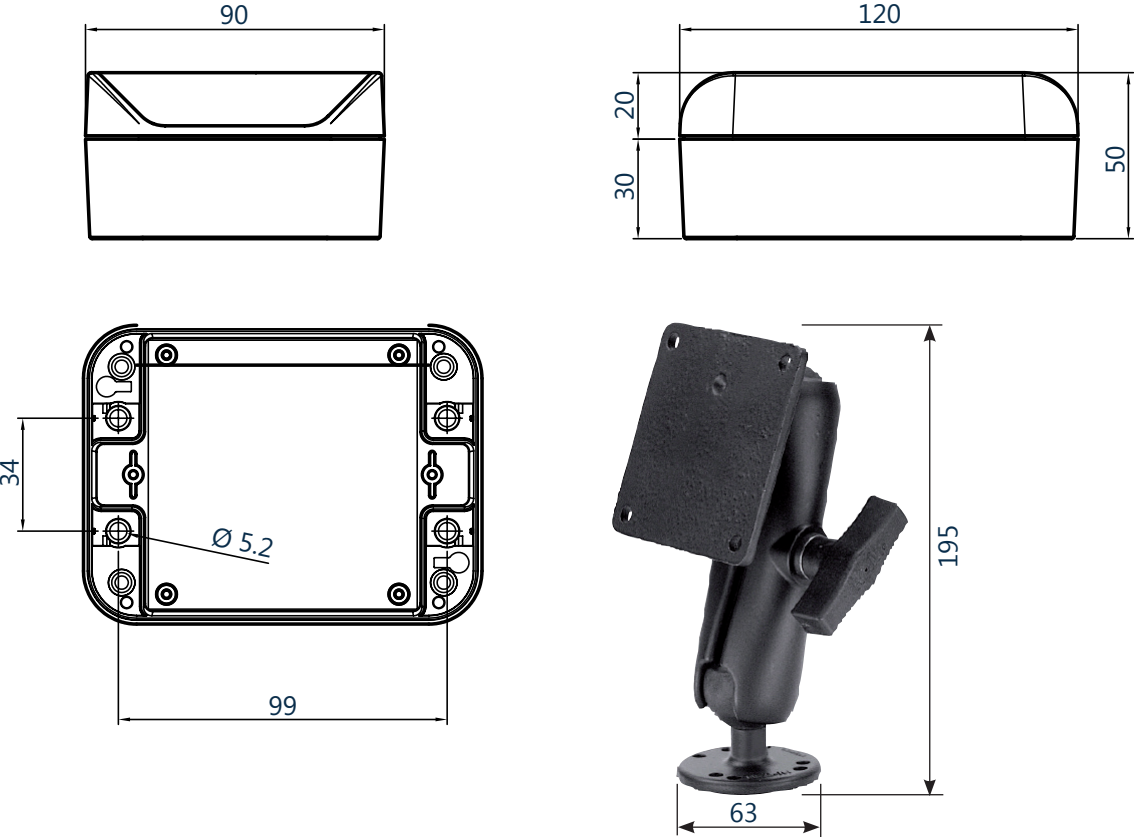

## Pressure drop curves

**CONTOIL® VZD/VZP 4, VZO 4 Qmin, VZO 4, VZO 4 OEM**

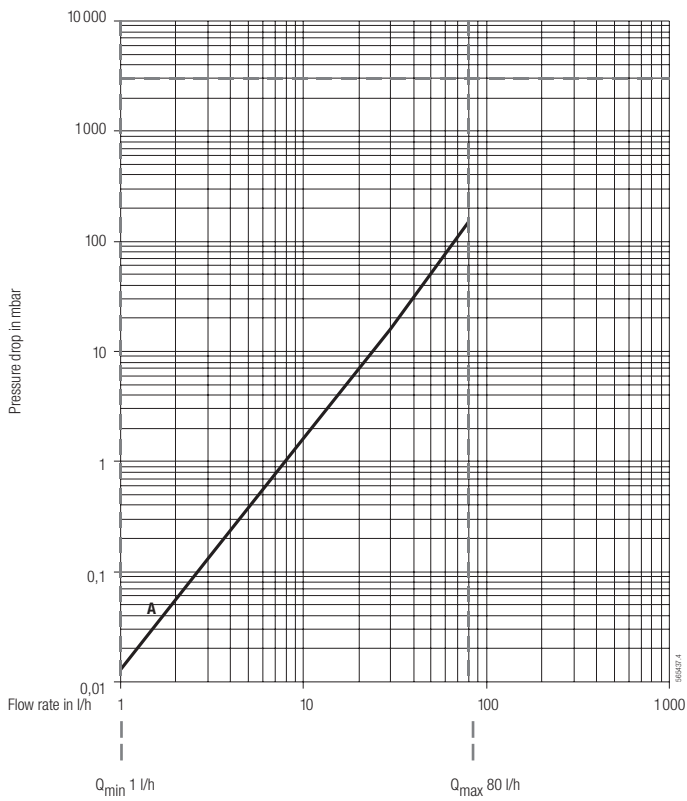

**CONTOIL® VZD/VZP 8, VZO 8, VZO 8 OEM, DFM 8D, DFM 8EDM, DFM 8ECO, DFM 12ECO**

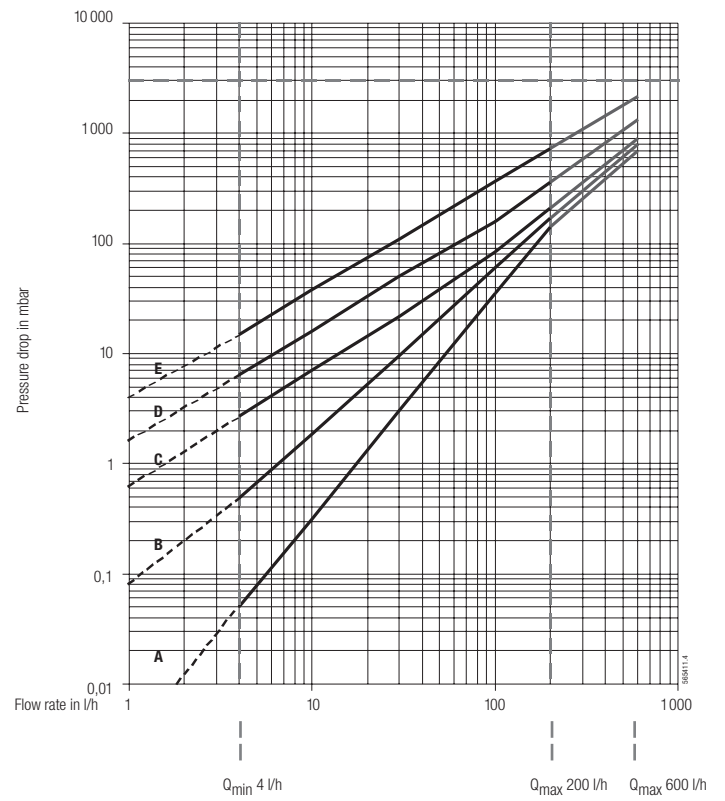





Viscosity diagrams:    A = 5 mPa.s            C = 100 mPa.s            E = 500 mPa.s  
                                   B = 50 mPa.s            D = 200 mPa.s

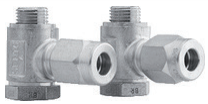

For a pressure drop of more than 1 bar, it is recommended to use the next larger meter size.  
 Maximum permissible pressure drop = 3 bar



## Accessories

VZO 4 + 8	Description		Art. No.
	Threaded connections kit	PS-Kit VZO 4 1/8" - 8	81583
	Mounting kit	PS-Kit VZO 8	81130
	Modification kit <sup>1)</sup>	VSR-SET VZD/VZP 4 1/8" to M14x1.5	80630
	Threaded connections to suit PS-Kit VZO 8	VSR 3/8"	81156

<sup>1)</sup> 2 sets needed for one flow meter.

DFM	Description		Art. No.
	Mounting bracket DMF-BC	DFM-MB	80485
	Hose connector <sup>1)</sup> include 1x hollow union, 1 single banjo body, 2x copper seal	DFM 8D, DFM 8EDM, DFM 8ECO, DFM 12ECO,	80447

<sup>1)</sup> 4 sets needed for one DFM 8D, DFM 8EDM, DFM 8ECO, DFM 12ECO.

### Mounting kit for VZO 8 - dimensions and some possible mounting positions

(all dimensions in mm)

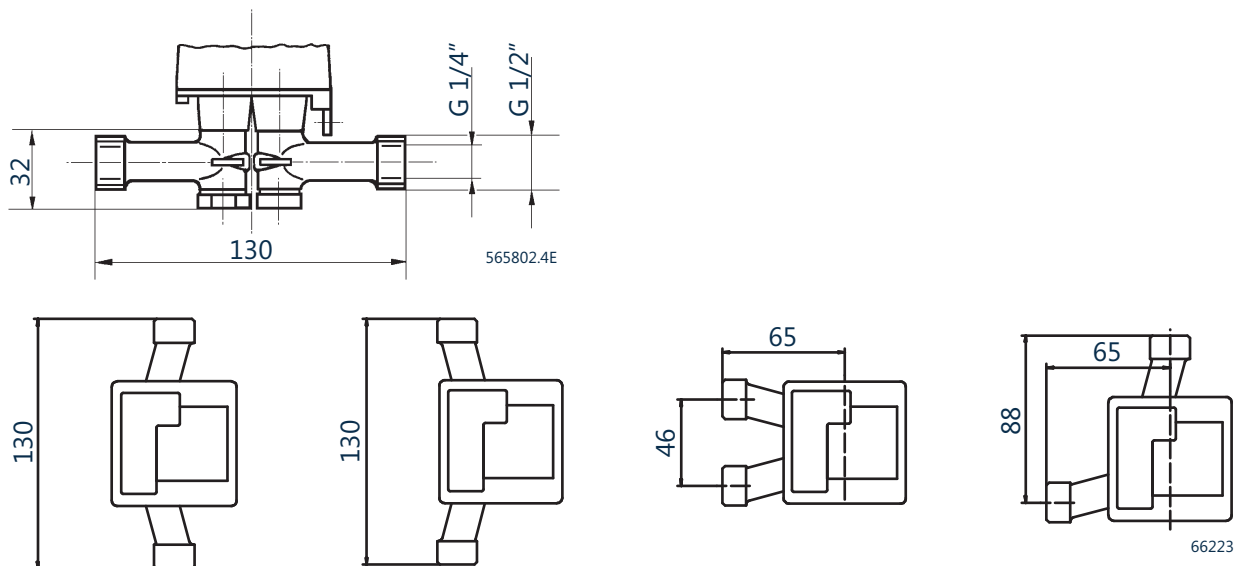

# Project planning notes

## Burner

### Mounting on pressure side of pump

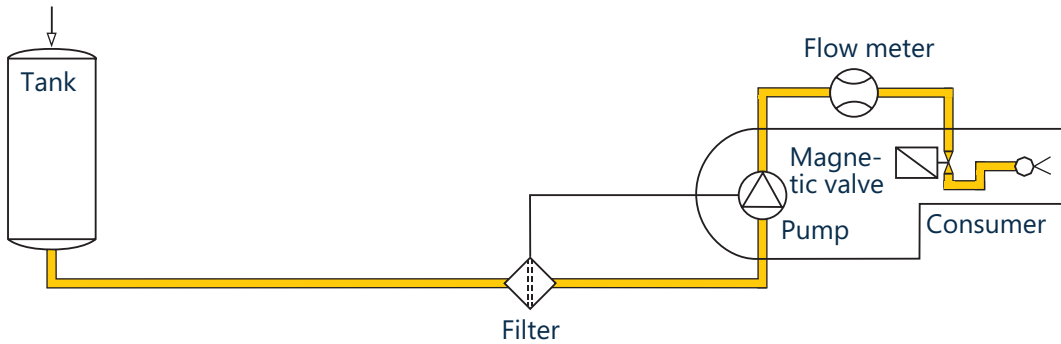

### Mounting on suction side of pump

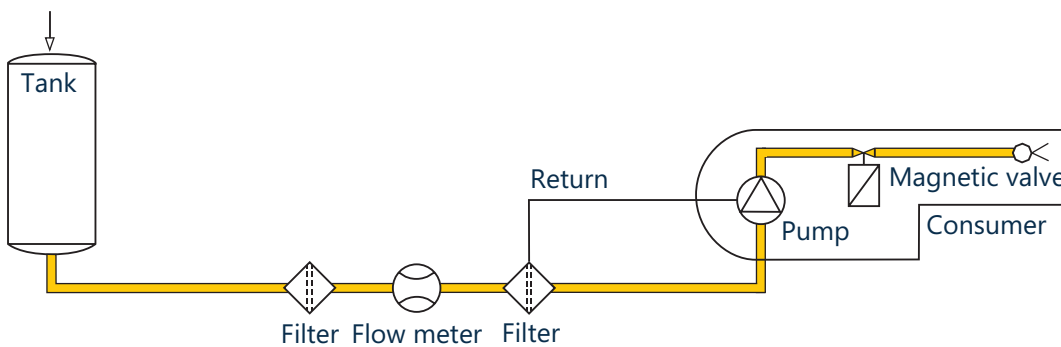

### Indicative values on power for burners

Burner		Flow meter		
Power	Flow rate heating fuel EL	Flow rate	Nominal diameter	
		$Q_{min}...Q_{cont}$		
up to kW	kg/h      l/h	l/h	DN	
500	42      50	1...50	4	
1300	113      135	4...135	8	
4000	336      400	10...400	12	

Formula for consumption in litres/hour:

$$\frac{\text{Burner power in kW}}{\text{Energy value of fuel in kWh/kg} \times \text{density in kg/dm}^3}$$

Example:

$$\frac{4000 \text{ kW}}{11.8 \text{ kWh/kg} \times 0.84 \text{ kg/dm}^3} = 4000 : 9.912 = 403 \text{ l/h}$$

# Engine

## Direct measurement

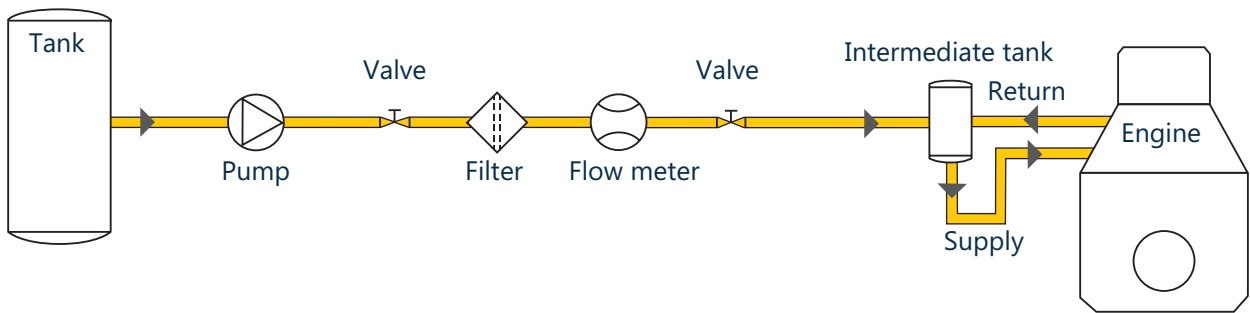

## Differential measurement

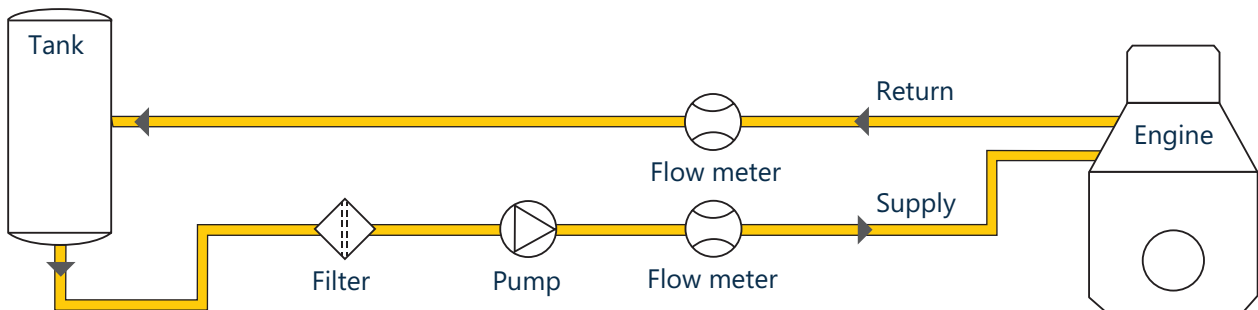

Engine		Flow meter <sup>1)</sup>	
Power	Diesel fuel consumption	Flow rate $Q_{min}...Q_{cont}$	Nominal diameter
up to PS	up to kW	l/h	DN
250	184	50	4
680	500	135	8
2000	1470	400	12

1) For differential measurement the flow meter has to be selected according to the pump flow rate and the flow in the return pipe.

Formula:  $1 \text{ DIN-PS} = 0,736 \text{ kW}$      $1 \text{ kg Diesel at } 0,84 \text{ kg/dm}^3 = 1,19 \text{ l}$   
 $1 \text{ kW} = 1,36 \text{ DIN-PS}$

Rule of thumb: approx. 190 g Diesel / kWh correspond to 0,226 l/h/kW  
 approx. 140 g Diesel / PS correspond to 0,167 l/h/PS

# How to obtain an optimal measurement

## Planning

Flow meters are precision measuring instruments. They achieve optimal results if

- a few important rules are observed during plant design,
- mounting and commissioning are carried out with care,
- the meters are used for their defined purpose only.

## Layout of pipework

- The quantities consumed by all consumers must be registered by the meter.
- Rotary piston meters do not require flow conditioners or inlet runs (after bends, T-pieces or fittings). They may be mounted in horizontal, vertical or inclined position, except with the head pointing downwards.
- The layout of piping must ensure that the meter is at all times filled with liquid and that no inclusions of air or gas may occur. Do not install the instrument at the highest point of the installation.
- Meter and accessory equipment must be easily accessible.

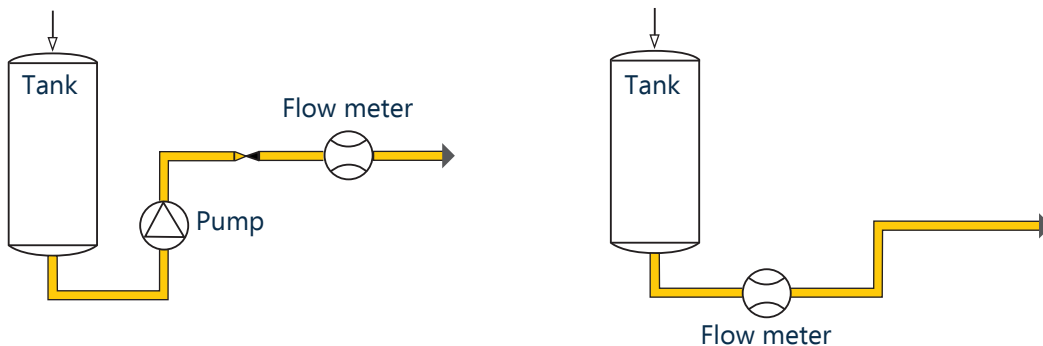

## Selection of the meter and ancillaries

To be considered when selecting the meter:

- Operating temperature
- Viscosity of the medium
- Operating pressure
- Flow rate
- Resistance of the material against fuel to be metered and working conditions

The technical data are valid for the following reference conditions: EL heating fuel/diesel at 20 °C. For higher viscosities or if the meter is mounted on the suction side of a pump, it is necessary to determine the pressure drop and the flow rate that can still be attained by using the pressure loss curves. If the pressure drop is more than 1 bar, it is advised to use the next larger meter size. Maximum permissible pressure drop = 3 bar.

## Dirt filter, safety filter

Filters are any way required in the system to protect engines and pumps to keep their performance and live time. For flow meters this is no different - that's why we recommend installing the flow meters (in flow direction) always directly after the filter. Some particles in the fuel are also from engine's wear and tear, that's why we also recommend a filter in the fuel return line. Usually basket type filters are best choice for the return line and automatic filters in the supply line. Major engine producers recommend a mesh size of 5 - 10 µm (automatic filters), especially to filter out very abrasive cut fines. It is best for the flow meter to install it between this automatic filter and the engine. The maximum filter mesh size for a respective meter can be found in below table.

Maximum mesh width for filters		
	Nominal diameter	mm
	DN 4	0.08
	DN 8	0.1

- The filter mounted in the meter inlet is only a safety filter and is too small to act as a dirt filter.
- If a dirt filter with the given mesh size is used, the safety filter in the meter inlet may be removed.

## Stop valves or cocks

In order to avoid backflow and draining, stop valves have to be mounted after the meter. Backflow and draining cause measuring errors and can damage the meter.

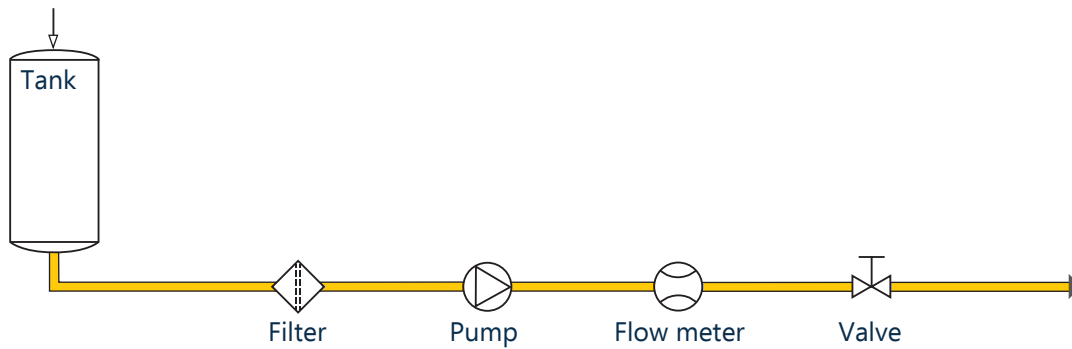

## Filling/Dosing

For filling and dosing the valve has to be mounted between meter and outlet. The shorter the pipe section between meter and outlet, the higher the accuracy. Fast opening and shutting of the valve should be avoided (pressure hammer!).

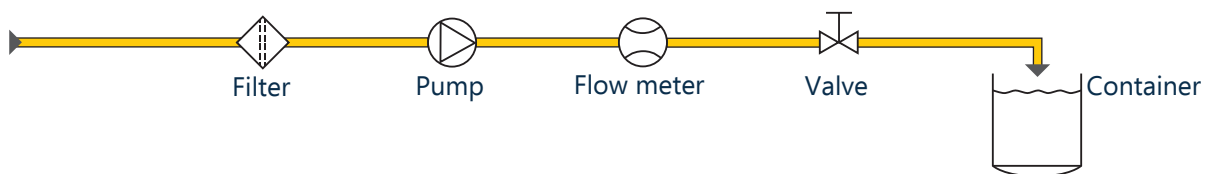

## Remote Processing/Ancillaries

Any backflow must be avoided on meters equipped with pulsers for remote processing. If this cannot be achieved by appropriate plant design, a non-return valve should be fitted.

## Electrical wiring and installations

Electrical wiring and installations are subject to statutory regulations which must be taken into account when planning the system. For installations in zones subject to explosion hazards, consult an appropriate expert.

The following factors should be taken into account during plant design:

- ancillaries connected to the meter
- environmental interference
- maximum permissible cable lengths (with or without amplifier)
- junction boxes, cable guides

# CONTOIL® meter with CE approval

## Installation examples

The installation drawings listed here are just examples and has to be interpreted as such.

### Installation position

All installation positions are valid, except upside down!

### Person responsible

The user/engineer is responsible for correct, legal installation.

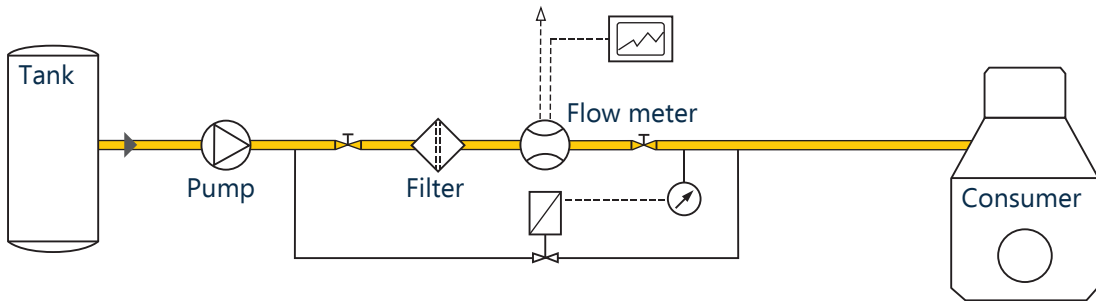
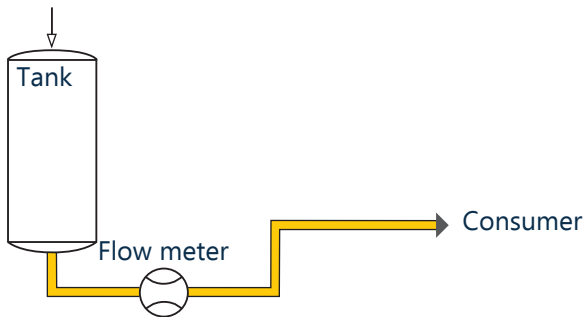
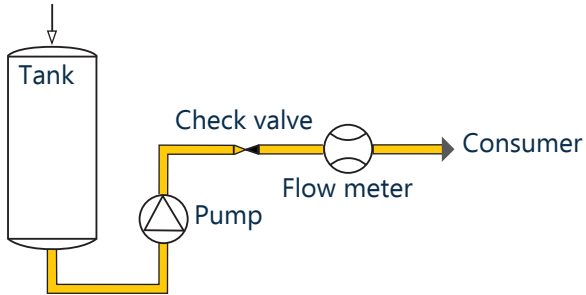

### Incorrect installation!

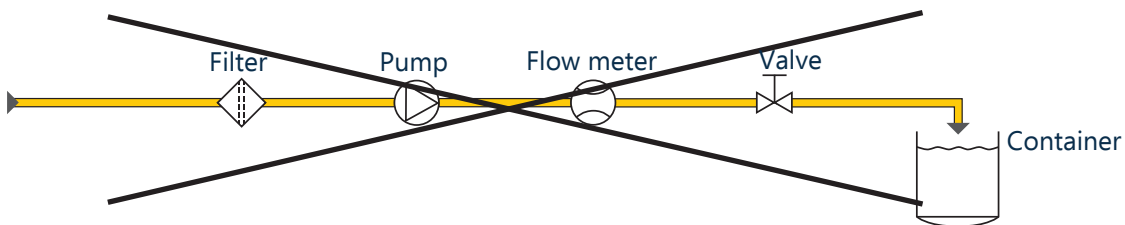

# Warranty, safety instructions

## Warranty Disclaimer

Aquametro Oil & Marine guarantees the quality of the product in the context of its General Terms of Business. The owner, operator or installer will be liable for the correct installation as well as the appropriate handling of the equipment upon its receipt.

- Please observe the application-, mounting- and operation-instructions.
- Use the unit exclusively for its designed purpose.
- Maintain the unit and service it according to prescriptions.
- Use accessories only if their applicability is technically safe.

## Safety rules and precautionary measures

The manufacturer accepts no responsibility if the following safety rules and precautions are disregarded.

- Modifications of the device implemented without preceding written consent from the manufacturer, will result in the immediate termination of product liability and warranty period.
- Installation, operation, maintenance and decommissioning of this device must be carried out by trained, qualified specialists, authorized by the manufacturer, operator or owner of the facility. The specialist must have read and understood these mounting- and operating-instructions and must follow the instructions here in.
- Check the voltage and the information on the type plate before installing the device.
- Check all connections, settings and technical specifications of peripherals which may be present.
- Open the housing or parts of housings, which electric or electronic components included, only when the electric power is turned off.
- Do not touch any electronic components (ESD sensitivity).
- Expose the system with respect to the mechanical load (pressure, temperature, IP protection, etc.), only to a maximum of the specified classifications.
- During operations that involve mechanical components of the system, release the pressure in the pipe system or reduce the temperature of the medium to a safe level for humans.
- None of the information stated here or elsewhere releases planners, installers and operators from their own careful and comprehensive assessment of the respective system configuration in terms of functional capability and operational safety.
- The local labor, safety laws and regulations must be adhered to.

**SWITZERLAND:** Aquametro Oil & Marine AG, Therwil  
**CHINA:** Aquametro Oil & Marine (CHINA) PTE. LTD., Singapore  
**GERMANY:** Aquametro Oil & Marine GmbH, Rostock  
**INDIA:** Aquametro Oil & Marine Rep. Office, Mumbai  
**JAPAN:** Aquametro Oil & Marine Rep. Office, Tokyo  
**KOREA:** Aquametro Oil & Marine Korea LTD., Busan  
**SINGAPORE:** Aquametro Oil & Marine (S.E.A.) PTE. LTD., Singapore  
**UAE:** Aquametro ME JLT, Dubai / UAE

**info@aquametro-oil-marine.com**  
info@aquametro-oil-marine.cn  
info@aquametro-oil-marine.de  
info@aquametro-oil-marine.in  
info@aquametro-oil-marine.jp  
info@aquametro-oil-marine.kr  
info@aquametro-oil-marine.sg  
info@aquametro-oil-marine.ae

**www.aquametro-oil-marine.com**  
www.aquametro-oil-marine.cn  
www.aquametro-oil-marine.de  
www.aquametro-oil-marine.in  
www.aquametro-oil-marine.jp  
www.aquametro-oil-marine.kr  
www.aquametro-oil-marine.sg  
www.aquametro-oil-marine.ae