

Platon Gapmeter Type SGUV & SGUL



DS1160

Features:

- Compact and rugged construction
- Optional flow alarm
- Maintenance possible under flow conditions
- Interchangeable components provide low cost unit
- Only one moving part



INTRODUCTION

Direct reading orifice plate flowmeter for pipe sizes 1 1/4" - 18" (30mm - 450mm).

Platon Gapmeters type SGUV and type SGUL are direct reading Flowmeters for clean liquids and gases in pipe sizes larger than 1 1/4" (30mm) and provide a robust and cost effective method of flow measurement. The indicator housing can be mounted locally to the pipe or remotely by the use of flexible impulse tubing.

ADVANTAGES

- Calibration for wide range of gases and liquids
- Available for various flanges
- Instantaneous reading
- Ease of installation

PRINCIPLE

The instrument is a neat combination of two measuring elements and is essentially a pressure differential device consisting primarily of an accurately machined orifice plate located in the main pipework. This produces a pressure drop proportional to the square of the flow rate. A secondary orifice restrictor located in the by-pass flowmeter is accurately calibrated to produce a by-pass flow that can be measured by the glass VA type flowmeter, scaled in terms of the main pipe flow. The metering elements are manufactured to a high standard of interchangeability with boldly marked indicating scales and dynamically balanced floats.

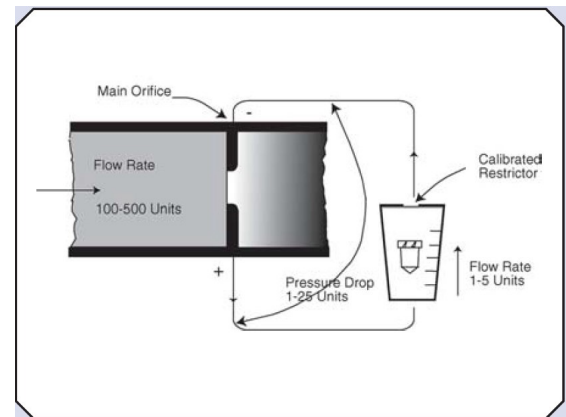

General Note

TT Electronics reserves the right to make changes in product specification without notice or liability. All information is subject to TT Electronics' own data and is considered accurate at time of going to print.

TT Electronics | Roxspur Measurement & Control Ltd
2 Downgate Drive, Sheffield, S4 8BT, England | Ph: +44(0)114 244 2521
www.roxspur.com | sales@roxspur.com

Platon Gapmeter Type SGUV & SGUL



DS1160

STANDARD SPECIFICATION

Orifice Plate:	316 Stainless Steel mounted in a steel carrier ring with blue polyester coating / all 316 Stainless Steel / all uPVC.
Impulse Pipe and Connectors:	Copper and plated brass / 316 Stainless Steel / uPVC for integral mounting. Brass and 316 Stainless Steel fittings with 50ft - 1/2" O.D. Nylon flexible tubing or clear soft PVC hose for remote mounting up to 25ft.
Isolating Valves:	316 Stainless Steel with PTFE head / uPVC.
Tube:	Borosilicate glass with 100mm fused-in ceramic scale.
Float:	316 Stainless Steel for water, red duralumin for air, or cored plastic.
Restrictor:	316 Stainless Steel / uPVC.
'O' Seals:	Nitrile (others available).
Housing:	Die-cast aluminum with white polyester coating, black bezel and perspex window.
Temperature Limitation:	80°C.
Pressure Test:	35 bar hydraulic on request.
Pressure Limitation:	25 bar liquids, 10 bar gases, 4 bar uPVC.
Accuracy:	±2.5% FSD.
Instructions:	Clamp between flanges as detailed in relevant operation manual.

STANDARD FLOW RANGES

Pipe Size		M ³ /h WATER @ 20°C		M ³ /h AIR @ ATP 20°C 760 Torr	
In	Mm	Pressure Drop mbar 10-250	10-63	Pressure Drop mbar 2.5-63	2.5-14
1 ¼	32	2-10	2-5	30-150	30-75
1 ½	40	3-15	3-7.5	40-200	40-100
2	50	5-25	5-12.5	80-400	80-200
2 ½	65	8-40	8-20	120-600	120-300
3	80	10-50	10-25	180-900	180-450
4	100	20-100	20-50	300-1500	300-750
5	125	30-150	30-75	480-2400	480-1200
6	150	40-200	40-100	720-3600	720-1800
8	200	80-400	80-200	1200-6000	1200-3000

- At maximum flowrate, 65% of the calculated pressure loss is recovered.
- The adjacent table is a useful guide to capacity, but in certain sizes this can be increased by 20% or reduced to as little as 10% of standard. Liquid capacity is unaffected by static pressure and is suitable for viscosities up to 3 cP. Approximately 75% higher capacity is available with a solid Stainless Steel float with a 5:1 range at 900 mbar maximum pressure drop. Viscosity up to 12 cP is also possible. Gas capacities relate to air discharging at atmospheric pressure. Low-pressure calibrations for 5 mbar maximum are available. For other conditions of temperature and pressure, special scales are available.
- LPCB units are approved for use on sprinkler installations. See leaflet DS1162 & DS1163.

DESIGN

Simplicity of construction is sought throughout, so that compact, inexpensive and safe assemblies result that are, at the same time, easy to install and to maintain.

The Main Orifice Assembly consists of an orifice plate and carrier. The plate, normally of Stainless Steel, is always made of material entirely resistant to the fluid to be measured and is sized and machined generally in accordance with British Standard practice detailed in BS EN ISO 5167.

The carrier is made from 1&euro thick material (metal or plastic) and of suitable diameter for clamping (within the bolt circle) between pipe flanges provided by the user. Corner tappings are provided in the carrier and are fitted with adapters to suit compression couplings for by-pass piping.

The Gapmeter Assembly comprises a standard GU Gapmeter fitted with a calibrated restrictor. The restrictor and indicating float are of material entirely resistant to the fluid, standard materials are Stainless Steel and Duralumin but alternatives are readily available. The restrictor is of small bore and must not be obstructed otherwise inaccuracy will result; being sited, however at the top of the Gapmeter glass metering tube, any obstruction can be easily seen.

General Note

TT Electronics reserves the right to make changes in product specification without notice or liability. All information is subject to TT Electronics' own data and is considered accurate at time of going to print.

TT Electronics | Roxspur Measurement & Control Ltd
2 Downgate Drive, Sheffield, S4 8BT, England | Ph: +44(0)114 244 2521
www.roxspur.com | sales@roxspur.com

Platon Gapmeter Type SGUV & SGUL



DS1160

The By-Pass Piping connecting the Main Orifice and Gapmeter is normally rigid (SGUV version) so that the whole assembly is handled as one unit. For most applications copper pipe and brass compression couplings are used, but these parts can be all of 316 Stainless Steel or rigid PVC where necessary. It is vital that the pressure loss due to friction in the by-pass pipe is constant as any change affects the calibration of the assembly. Where the SGUV assemblies cannot be used, flexible nylon pipe (SGUL version) can be supplied for a maximum "reach" of 25 feet.

CALIBRATION

The Main Orifice is calculated from data supplied by the user to provide a pressure-differential range to suit a standard Gapmeter assembly, all other components are dimensionally interchangeable. Calculations are made on the assumption that BS EN ISO practice is followed for the main orifice installation, e.g. straight pipe requirement for maximum capacities are 20 diameters upstream and 5 downstream.

The Gapmeter tube is scaled as close as possible to the user's needs as the criterion of interchangeability allows. All figures and lines are printed to a high reading standard. Arbitrary scales and charts are available where one indicator may be used with several main orifices, or under varying conditions of pressure or temperature. With proper installation, accuracy of $\pm 2.5\%$ of full-scale reading is achieved.

INSTALLATION

The best place for a Shunt Gapmeter is in a straight length of horizontal or vertical pipe at a flanged joint easily accessible for reading purposes; the flow may be in any direction. If such a position does not exist, a straight pipe should be selected and long reach fittings used so that the Gapmeter indicator can be mounted conveniently for reading on a wall or panel.

The orifice carrier must be centred within the pipe flanges so that the orifice is co-axial with the pipe and so that the approach bore is smooth. The direction arrow must be aligned with the flow. Gaskets must not project into the pipe bore for the same reason: they are best cut with the inside diameter 10% oversize. The approach pipe must be of smooth bore and non-corroding.

The relative positions of the Main Orifice and Gapmeter are best determined by the need to avoid condensation in the indicator when measuring gas flows, and the need to obviate air locks when measuring liquids. Wherever possible ensure that with liquids the Gapmeter is below the orifice and with gases that the Gapmeter is above the orifice.



Close coupled vertical orientation for gaseous flows.



Close coupled horizontal orientation for liquid flows.

ORDERING DETAILS

Nature of fluid (and details of density and viscosity, if unusual). State any corrosion hazard. Working conditions of temperature and pressure.

Whether pressure test certificate required.

Details of size, orientation of pipe and existing flange drilling.

Direction of flow and whether close-coupled or long-reach fittings are required.

General Note

TT Electronics reserves the right to make changes in product specification without notice or liability. All information is subject to TT Electronics' own data and is considered accurate at time of going to print.

TT Electronics | Roxspur Measurement & Control Ltd
2 Downgate Drive, Sheffield, S4 8BT, England | Ph: +44(0)114 244 2521
www.roxspur.com | sales@roxspur.com

Platon Gapmeter Type SGUV & SGUL



DS1160

DIMENSIONS

GAPMETER TYPE SGUV

A		B	
Inches	mm	Inches	mm
1¼	32	2 15/16	75
1½	40	3 3/8	86
2	50	3 7/8	98
2 ½	65	4 3/8	111
3	80	5 1/8	130
4	100	6 3/8	162
5	125	7 5/8	194
6	150	8 ½	216
8	200	10 3/4	273

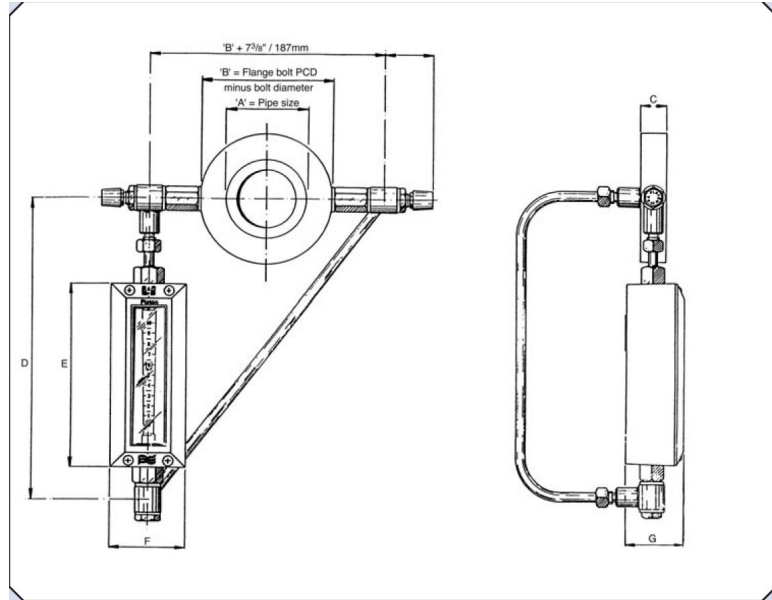

GAPMETER TYPE SGUL

	Inches	mm
C	1	25
D	12 ½	317
E	7	178
F	2 7/8	73
G	2 3/8	60

Note: Dimensions for SGUV (all plastic construction — contact Sales for dimensions).

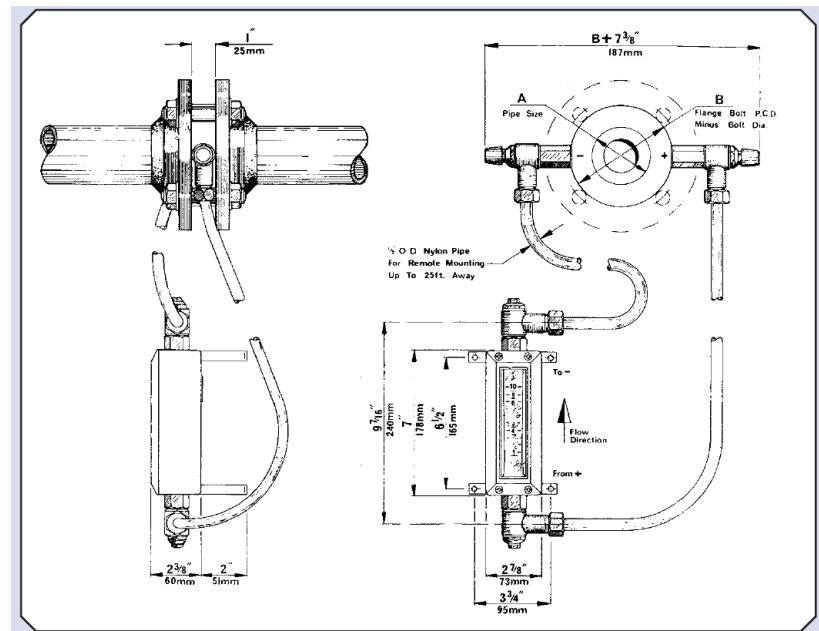

Every effort has been made during the preparation of this document to ensure the accuracy of statements and specifications. However, we do not accept liability for damage, injury, loss or expense caused by errors or omissions made. We reserve the right to withdraw or amend products or documentation without notice.

Head Office: 2 Downgate Drive, Sheffield, S4 8BT, England
Tel: +44(0)114 244 2521 Fax: +44(0)114 243 4838



CERTIFICATE No. FM22358

General Note

TT Electronics reserves the right to make changes in product specification without notice or liability. All information is subject to TT Electronics' own data and is considered accurate at time of going to print.

TT Electronics | Roxspur Measurement & Control Ltd
2 Downgate Drive, Sheffield, S4 8BT, England | Ph: +44(0)114 244 2521
www.roxspur.com | sales@roxspur.com