

### Specifications

Nominal Voltage	2V	
Number of cell	1	
Nominal Capacity	2000Ah@ 10hr-rate (200.0A to 1.80V/cell @25°C)	
Dimensions	Length	397±1mm (15.6 inches)
	Width	212±1mm (8.35 inches)
	Height	774±1mm (30.5 inches)
	Total Height	813±1mm (32.0 inches)
Weight	Approx. 155Kg	
Terminal	M8, Φ=20	
Container Material	A.B.S. (UL94-HB), Flammability resistance of UL94-V1 can be available upon request.	
Rated Capacity	2000Ah	10hr-rate (200.0A to 1.80V/cell @25°C)
	1793Ah	5hr-rate (358.6A to 1.70V/cell @25°C)
	1217Ah	1hr-rate (1217A to 1.60V/cell @25°C)
Max. Discharge Current	10000A(5sec)	
Max. Charging Current	500A	
Internal Resistance	Approx.0.15 mΩ(Fully charged)	
Operating Temp. Range	Maximum	: -40°C~55°C
	Recommended	: -15°C~50°C
	Storage	: -20°C~40°C
Normal Operating Tem. Range	25±5°C	
Cycle Use	Charging Current:	≤500A
	Voltage:	2.35V~2.40V
	Temperature compensation:	-5mV/°C
Standby Use	Charging Current:	No limit
	Voltage:	2.25V
	Temperature compensation:	-3mV/°C
Self-Discharge	less than 2% every month	
Design Life	18 years (floating charge)	

### Main Advantages

- >> adopt tubular plate with GEL technology
- >> longest lifespan under deep discharge
- >> Strong temperature resistance performance
- >> Better charge reception capability
- >> 20 years design life

### Applications

- >> Solar Power and Wind Power
- >> Telecom Power and DC Power
- >> Electric Power System
- >> Electronic instruments

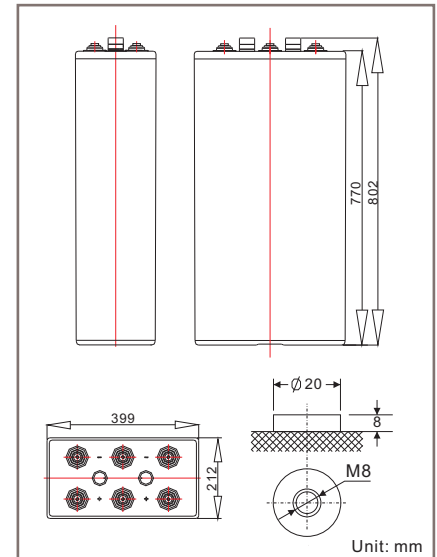

### Constant Current Discharge Characteristics: A (25°C)

F. V/Time	15min	30min	1h	2h	3h	4h	5h	6h	8h	10h
1.60V/cell	2202	1761	1217	755.6	544.3	434.6	369.2	324.6	261.0	212.8
1.65V/cell	2135	1708	1184	741.8	537.6	431.5	364.9	319.4	258.6	211.8
1.70V/cell	2004	1643	1153	727.3	528.8	423.1	358.6	314.2	256.7	210.5
1.75V/cell	1898	1576	1113	701.6	512.4	412.7	352.1	308.4	251.3	208.4
1.80V/cell	1692	1434	1071	668.4	507.3	400.8	346.2	300.0	245.8	202.6
1.85V/cell	1415	1217	982.3	645.1	491.2	392.5	336.5	289.3	238.4	199.8

### Constant Current Discharge Characteristics: W (25°C)

F. V/Time	15min	30min	1h	2h	3h	4h	5h	6h	8h	10h
1.60V/cell	4424	3489	2687	1485	1128	893.1	758.4	655.2	546.6	456.7
1.65V/cell	4206	3314	2493	1468	1113	884.9	746.4	651.0	534.8	448.2
1.70V/cell	4009	3158	2342	1452	1107	876.7	730.0	646.4	531.2	439.6
1.75V/cell	3785	3031	2190	1408	1074	841.1	712.1	630.6	525.4	436.4
1.80V/cell	3542	2905	2074	1361	1048	824.6	674.3	603.3	49.18	41.25
1.85V/cell	3321	2794	1926	1307	995.4	784.2	662.3	584.7	48.26	39.94

## Discharge Characteristics Curve

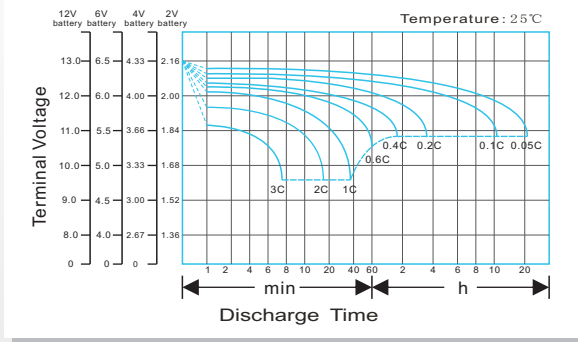

## Charging Characteristics Curve

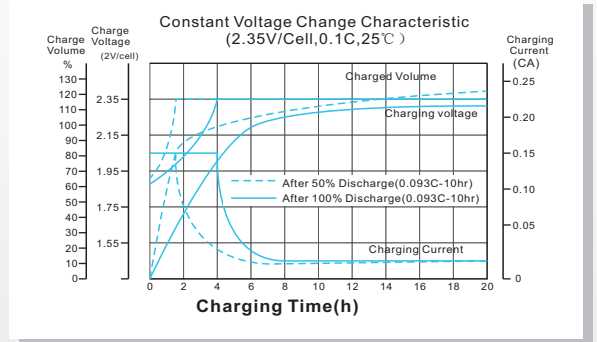

## Cycle life in relation to depth of Discharge

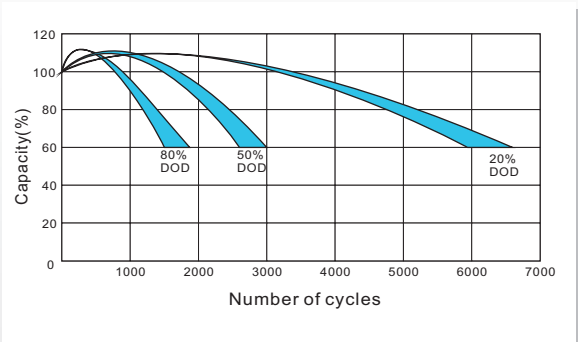

## Temperature effects on Capacity

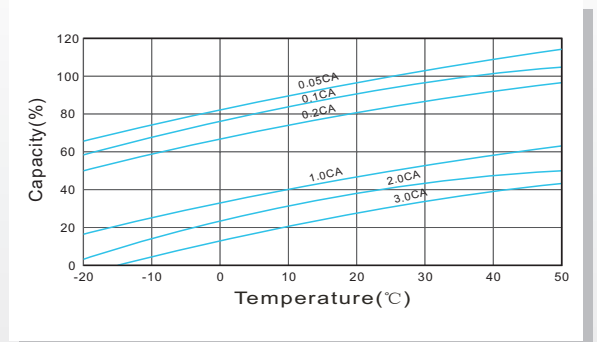

## Relationship between charging voltage and temperature

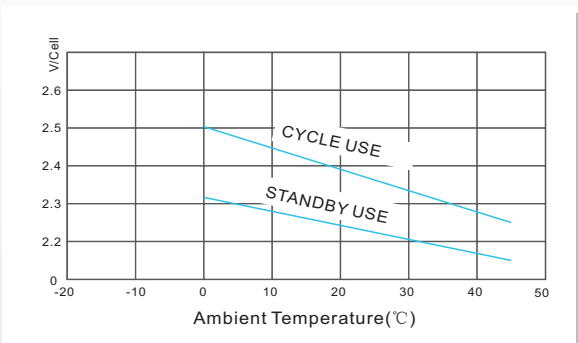

## Self-discharge Characteristics

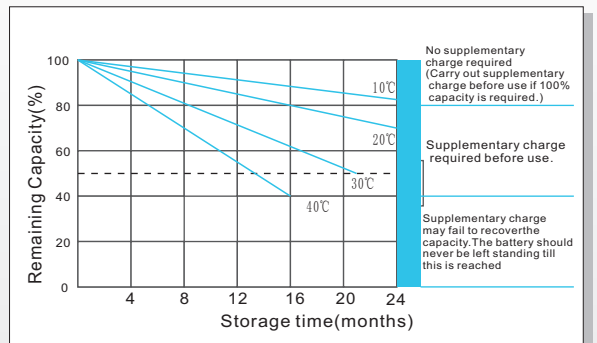

## Temperature effects on Float life

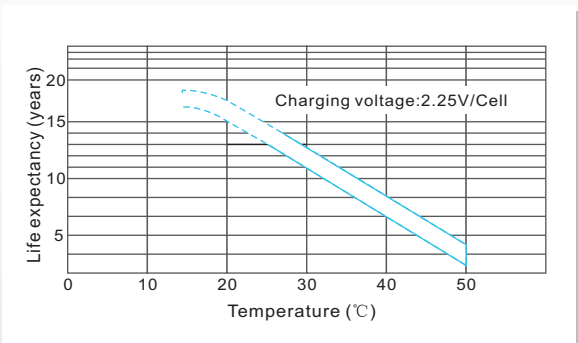

## Life Characteristics of Standby use

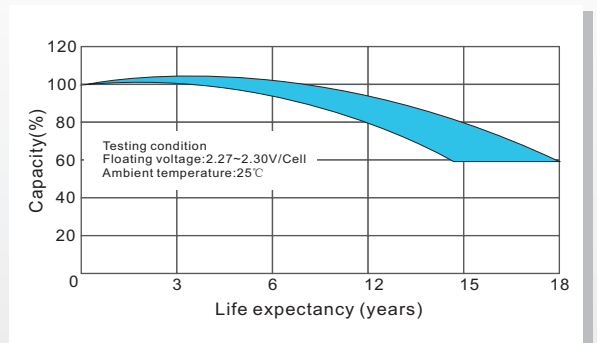

Contact us:

Click / Scan Here

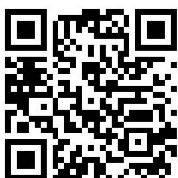

**NIMAC POWER SYSTEMS (M) SDN BHD (425245-D)**  
 No. 9, Jalan SC 8, Taman Perindustrian Sungai Chua, 43000 Kajang, Selangor Darul Ehsan, Malaysia.  
 Tel: +603-8733 9163 / 8737 0168 / 8736 5168 Fax: +603-8735 0999 / 8734 6641  
 E-mail: alee@nimac.com.my Website: <http://www.nimac.com.my> GST No. 001620312064