



# GKM C4000

## Combination Cold Potable Water Meters

Combining two outstanding GKM metering technologies in one extremely compact unit, the GKM C4000's innovative in-line design delivers highly accurate bulk flow metering for application with large variations in flow rate helping to ensure optimum revenue collection.

### FEATURES

---

- Two inductive registers for improved output performance and security
- High turndown ratio
- Highly accurate bulk flow metering for application with large variations in flow rate
- Designed to maximise revenue collection
- Compact, in-line construction for easy installation
- Available in sizes from 50mm to 100mm
- Longer wear life for optimum accuracy

Available in a range of three sizes and suitable for flow rates up to 125m<sup>3</sup>/h the C4000 features an innovative in-line design which delivers significant benefits, not only at installation but throughout its working lifetime. Offering the benefits of inductive register technology and combining the performance of both the H4000 and V220 range of meters, the C4000 measuring range ensures maximum revenue collection. The C4000 complies with all relevant international quality standards.

### Compact, cost-effective, dependable

With a compact in-line design that simplifies the specification process by eliminating the need to differentiate between left or right-handed by-pass meters, the C4000 also features an easy-change metering insert, carrying both primary and secondary metering module. This can be removed as a complete assembly, significantly reducing the time required for calibration, maintenance or replacement. As with all Elster meters, the product is designed and manufactured to rigorous quality standards for trouble-free operation - whatever its working environment. The C4000's superb design offers many features which increase its life cycle and reduce costs, including wear-resistant jewelled rotor bearing, tungsten carbide thrust pads and stub spindles with factory-potted moisture resistant electrical connections.

### Enhanced communication and security

Using an inductive register to deliver enhanced communication performance and tamper-proof security, the C4000 provides effective protection against fraud. Compatible with Emeris PR6 and PR7 inductive pulse transmitters, the product features both high- and low-speed bi-directional pulse capabilities as standard, and is fully compatible with other common ancillary devices including data logger and AMR systems.

### In-line strainer

The use of GKM H4000 strainer is recommended to protect the rotor and help reduce the effect of turbulence.

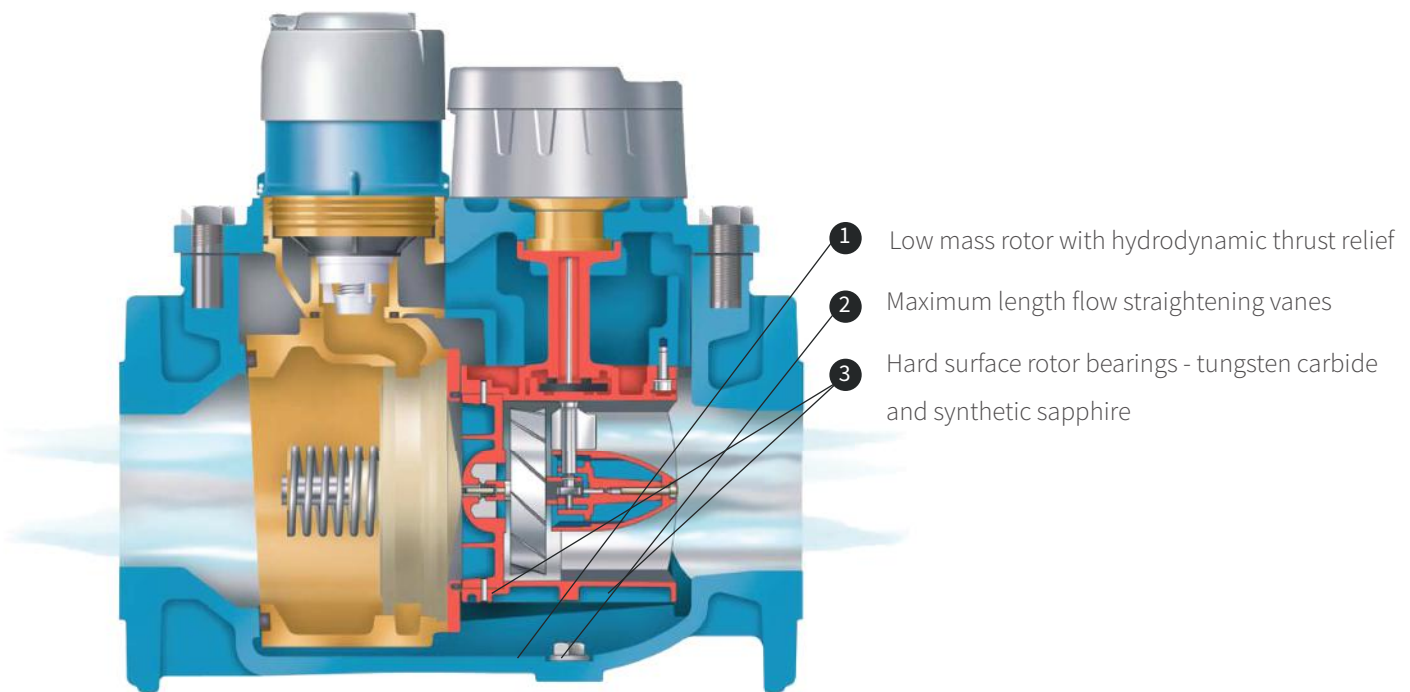

### C&I inductive register

- 1 Inductive target for bi-directional pulse communications
- 2 Start tell-tale for easy-to-see flow detection
- 3 Easy to read-display – 6-figure display for sizes 50mm to 100mm

## Product Specification

Size of Meter			DN50	DN80	DN100
Minimum Flowrate	$Q_1 \pm 5\%$	$m^3/h$	0.025	0.025	0.025
Transitional Flowrate	$Q_2 \pm 2\%$	$m^3/h$	0.040	0.040	0.040
Permanent Flowrate	$Q_3 \pm 2\%$	$m^3/h$	25	63	100
Overload Flowrate	$Q_4 \pm 2\%$	$m^3/h$	31.25	78.75	125
Measuring Range (R)	$Q_3/Q_1$		1000	2500	4000
Changeover Flowrate	$Q_{x1}$	$m^3/h$	0.8 - 1.4	1.1 - 1.9	1.1 - 2.0
Changeover Flowrate	$Q_{x2}$	$m^3/h$	1.6-2.0	2.1 - 3.0	2.1 - 3.0
Max Admissible Pressure		bar	16	16	16
Pressure Loss Class $\Delta P$		$m^3$	0.63	0.63	0.63
Indicating Range (Larger Meter)		$m^3$	999 999	999 999	999 999
Verification Scale Interval (Larger Meter)		$m^3$	0.0005	0.0005	0.0005
Indicating Range (Smaller by-pass Meter)		$m^3$	99 999	99 999	99 999
Verification Scale Interval (Smaller by-pass Meter)		$m^3$	0.00002	0.00002	0.00002
Working pressure range		bar	From 0.3 to 16		
Orientation requirements	all positions but not head down				

\*It is highly recommended to install GKM H4000 Strainer before the bulk water meter to protect the meter. The strainer functions as a filter to prevent solid objects in the pipe from damaging the meter.

## Dimension

Size of Meter	DN50	DN80	DN100
Overall length (A)	300	350	350
Height (B)	80	104	115
Diameter (C)	166	201	228
Height (D)	225	245	255
Height with lid open (E)	291	316	321
Width (F)	105	125	140
Width (G)	100	125	140
Mechanism removal (H)	400	475	500
Weight (kg)	25	35	40

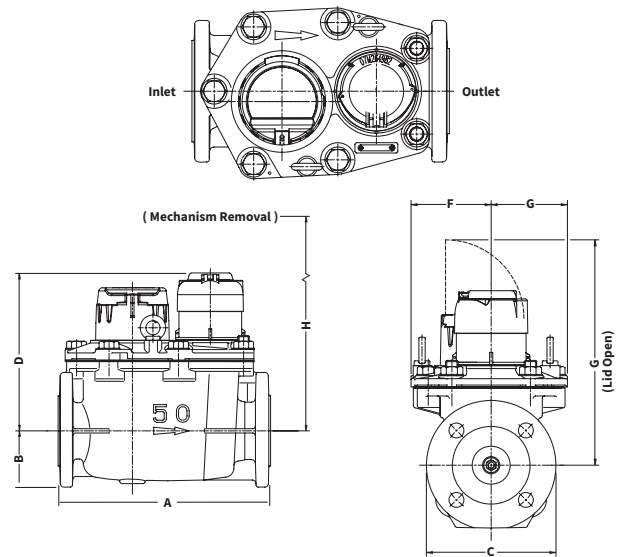

Accuracy Curve and Pulse Connectivity shown overleaf.

## Typical Accuracy Curve

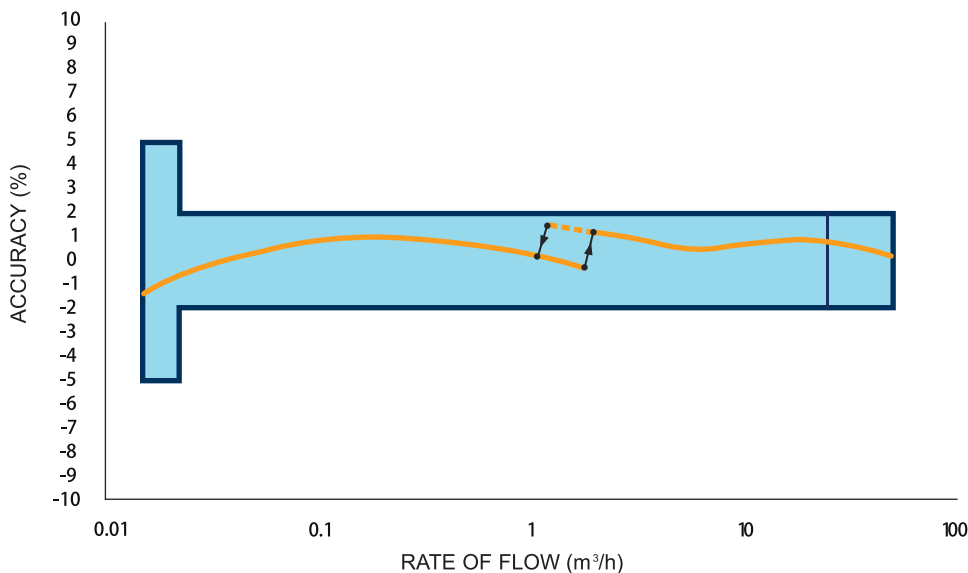

## PR7 designed for the H4000 range of bulk meter Pulse Connectivity

Calculating Pulse Weights when fitted with PR7 inductive pulser

Pulse Weight is calculated by multiplying the Register 'Pulse Factor' (P) by the PR7 'K-Factor' (K) Pulse Weight (Liters per Pulse) =  $P \times K$

Size	Pulse Factor	K-Factor			
		K1	K10	K100	K1000
50mm	P:1	1 ltr	10 ltr	100 ltr	1,000 ltr
80mm	P:1	1 ltr	10 ltr	100 ltr	1,000 ltr
100mm	P:1	1 ltr	10 ltr	100 ltr	1,000 ltr

PR7 is an open collector pulse transmitter suitable for data logging, AMR and telemetry equipment. Check with your equipment supplier for full details of compatibility. The PR7 with a K factor of 1 should be used with advanced data loggers, those capable of accepting a 5ms width pulse. Other outputs ( $K \ll 1$ ) have a variable pulse width. These can be used with any data lodger.



**1** On this example 50mm C4000 register, the user can identify from the dial plate both the:

- Type of pulser to use ie PR7
- Pulse factor ie P:1

## PR6 Designed for the V200 range of volumetric meters

Meter pulse factor	Pulse type	K-Factor	Primary output pulse weight litres/ pulse	Secondary output pulse weight litres/ pulse
PR6P:1	PR6	1:1	1	1
PR6P:10	PR6	1:1	10	10

The C4000 needs a PR6 for the V220 volumetric meter and a PR7 for the Woltmann meter.

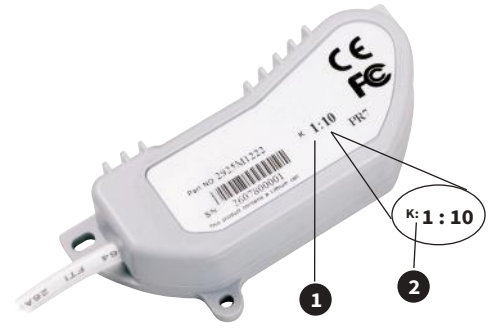

- 1 On the PR7 unit the user can identify from the label the K-Factors for each output channel
- 2 Primary Output K-Factors
- 3 Secondary Output K-Factors

Pressure equipment directive 97/23/EC.  
This product is applicable in network for the supply, distribution and discharge of water and associated equipment and is therefore exempt.

Note: Specifications are subject to change without notice.

## Water Meter Accessories

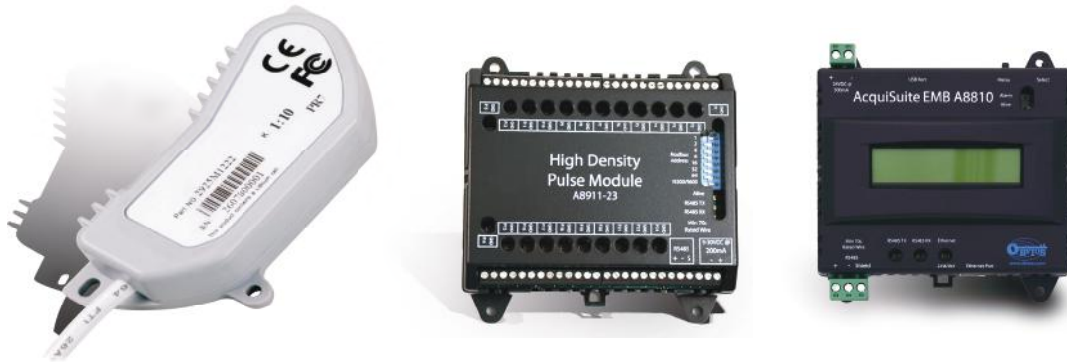

We take pride in being **Your Trusted Engineering Partner.**  
Find out more about us at [www.georgekent.net](http://www.georgekent.net)

While George Kent strives to make the content of its marketing materials as timely and accurate as possible, George Kent makes no claims, promises, or guarantees about the accuracy, completeness, or adequacy of, and expressly disclaims liability for errors and omissions in, such materials. No warranty of any kind, implied, expressed, or statutory, including but not limited to the warranties of non-infringement of third party rights, title, merchantability, and fitness for a particular purpose, is given with respect to the content of these marketing materials.  
© Copyright 2018 George Kent. All rights reserved.