

Conex | Bänninger

Conex Compression



 Conex Compression Technical Brochure

Contents

1.0: General	1
1.1 Quality and certification	1
1.2 Product structure	1
1.3 Materials	2
1.4 Threaded connections.....	2
1.5 Tube compatibility.....	2
1.6 Storage and handling	2
1.7 COSHH.....	2
1.8 Finish availability.....	2
1.9 Conversion Data (Metric to Imperial).....	2
2.0: Jointing instructions water applications	3
2.1 Joint fitting sizes 6mm – 54mm	3
2.2 Flange fittings sizes 67mm – 108mm.....	5
2.3 Internal reducers.....	5
2.4 Jointing instructions gas applications.....	6
2.5 Minimum distances and insertion depths	6
3.0: Applications	7
4.0: Operating parameters	8
4.1 Operating temperature and pressure water applications with metal tubes.....	8
5.0: Other Installations.....	9
5.1 Solar installations	9
5.2 Gas installations	9
6.0: Loss coefficients	10
7.0: Pre-commissioning water systems	12
7.1 Water	12
7.2 Copper and copper alloy	12
7.3 Chemical types, and their function(s) found in commercial products	12
7.4 Flushing of water installations	13
7.5 Testing and commissioning drinking water installations.....	13
7.6 Water softening.....	13
8.0: Corrosion	13
8.1 Stress corrosion cracking.....	13
8.2 Corrosion on copper and copper alloys	13
8.3 Chemical types, and their function(s) found in commercial products	13
9.0: The Range	14
10.0: Guarantee	40

1.0 General

Conex Compression fittings are manufactured from high quality brass materials which ensure a permanently tight and secure connection, without the use of special tooling or additional sealant. These fittings are suitable for connecting a wide range of tubes, including copper tubes in accordance with EN 1057, carbon steel to EN 10305, stainless steel to EN 10312 and plastic pipes to BS 7291, EN 15875 and EN 15876.

1.1 Quality and certification

Conex Compression fittings are designed to minimise flow restriction. They are designed with a symmetrical compression ring which provides a seal within the cone of the fitting and capnut providing a two point seal on the tube. The simple principle of a Conex Compression joint is shown sectioned in figure 1.

With over 100 years of experience in manufacturing innovative technology, Conex Bänninger fittings are BSI Kitemark approved and manufactured in an production facility with an accredited EN ISO 9001 Quality management system.

Conex Compression fittings are tested and approved, for use with drinking water up to 108mm and for gas applications up to 28mm. Tested and certified by independent European certification bodies such as WRAS- Water Regulations Advisory Scheme confirming its suitability and reliability for drinking water use.

Conex Compression fittings are approved for various applications and certified by the following bodies:

Table 1: Certificates and approvals

WRAS	UK
BSI Kitemark	UK
DVGW	Germany
DNV	Germany
Bureau Veritas	Germany
KIWA	Netherlands
Gastec	Netherlands
SVGW	Switzerland
ARGB-KVGB	Belgium
PZH	Poland
TYSK	Ukraine
PCT	Russia
EMI	Hungary

1.2 Product structure

Conex Compression fittings are manufactured in accordance with EN 1254 parts 2 and 4 consisting of the following components:

- Fitting body with machined tube stop
- Compression ring (Olive)
- Capnut

Conex Compression unique ribbed pattern capnuts are supplied in sizes 15mm to 28mm fittings.

Sizes 35mm, 42mm and 54mm are supplied with octagonal capnuts. Fittings in 66.7mm, 76.1mm and 108mm sizes incorporate loose compression plates, where tightening is through six 3/8" BSW nuts. Conex Compression fittings are also available in hex nut from sizes 6mm to 28mm.

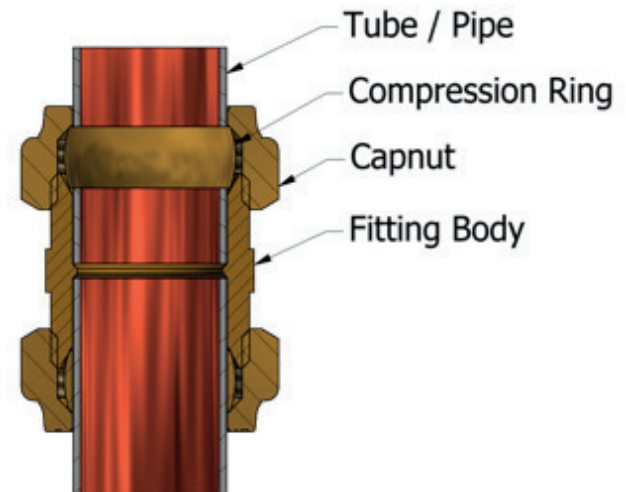

Figure 1

1.3 Materials

Conex Compression fittings are available in duplex yellow brass or dezincification resistant brass and Red Brass (Gunmetal). Components in contact with water are manufactured using low lead materials complying with the European requirements for materials in contact with drinking water.

Low lead specification

- Standard material: EN 12165 CW 617N-DW
- DZR material: EN 12165 CW 511L
- Red Brass (Gunmetal): EN 1982 CC 499K

These materials meet the requirements of the 'UBA list of hygienically suitable materials for drinking water', and are ideal for all types of drinking water systems without restriction.

1.4 Threaded connections

Conex Compression fittings are available with male and female threaded connections. These threaded ends incorporate a hexagon or octagon for tightening the joint. They are manufactured to the following standards:

- Female threads to ISO 228 parallel.
- Male threads are either ISO 228 male parallel or ISO 7 taper.
- ISO 228 parallel threads require a sealing washer to affect the seal on the mating faces of the joint. Please note: these must not be used in gas installations.
- ISO 7 taper threads are sealed on the thread form with appropriate sealing material. Suitable for gas applications up to 1".

1.5 Tube compatibility

Conex Compression connectors can be combined with:

- Copper tubes in accordance with EN 1057 up to 108mm in R220 (Liner Required), R250 and R290 temper condition.
- Stainless steel tubes up to 28mm in accordance with EN 10312, series 1 or 2.
- Carbon steel tubes up to 28mm in accordance with EN 10305
- Polybutylene (PB) to BS 7291 part 2 & EN 15876 up to 28mm.
- PE-X pipe to BS 7291 part 3 and EN 15875 up to 28mm.

For more details please see. 4.0 Operating parameters.

1.6 Storage and handling

It is advisable to leave the fittings in the packaging to protect the fitting prior to installation. Please store in a cool and dry place to protect the fittings from contamination, damage and dirt.

Cone face connectors to EN 1254-2 (BS 864: Part 2) rely on a metal x metal seal and care should be taken to avoid damage prior to assembly. Should difficulty be experienced, the use of a WRAS listed sealant is permitted. Do not over tighten.

1.7 COSHH

It is the responsibility of the end user to ensure that adequate protection is available where required and the necessary information regarding possible health and safety regulations is adhered to. Copper and copper alloy fittings are considered non-hazardous under normal circumstances. COSHH

1.8 Finish availability

Apart from the natural brass finish, Conex Compression fittings are also available in nickel or chrome plated finish in accordance with EN 248.

Note: it is recommended that you contact our sales team for availability of any of our Conex Compression fittings in the plated versions.

Table 2: Conversion data for connecting metric fittings to imperial tube

Conversion table		
Metric Size	Imperial Size	Method of Adaptation
12mm	3/8"	*Compatible – No adaptor required
15mm	1/2"	*Compatible – No adaptor required
22mm	3/4"	Exchange existing 22mm 65 compression ring for a 3/4" 65 compression ring (04-1020065--)
28mm	1"	Exchange existing 28mm 65 compression ring for a 1" 65 compression ring (05-1020065--)
35mm	1-1/4"	Exchange existing 35mm 65 compression ring for a 1-1/4" 65 compression ring (06-1020065--)
42mm	1-1/2"	Exchange existing 42mm 65 compression ring for a 42 x 1-1/2" S68S Adaptor Ring (K071020068S-)
54mm	2"	*Compatible – No adaptor required
67mm	2-1/2"	*Compatible – No adaptor required
76.1mm	3"	No adaptation possible a 76 x 3" 3011M coupler (R3020203011M) must be used.
108mm	4"	Exchange existing 108mm 65 compression ring for a 108 x 4" S68S adaptor ring (S405020068S-)

2.0 Jointing instructions water applications

2.1 Sizes 6mm – 54mm

It is advisable to leave the fittings in the packaging prior to final installation to protect them from contamination and damage. As part of the installation process the space required and the minimum distance for Conex Compression fittings must be observed. For copper tubes in a R220 annealed condition and plastic tubes to BS 7291, EN 15875 and EN 15876 supporting liners must be used.

2.1.1 Cutting to length

Ensure that the tube and fitting sizes are compatible. Cut the tube end square but ensure tube retains its shape. The tube will then make even contact with the tube stop in the body of the fitting. The use of a rotary tube cutter is recommended where practical.

Note: For copper please note: Cut the tube to length using a rotary tube cutter, fine-toothed hacksaw or a special electric tube saw. An angle grinder or a cutting torch must not be used.

For plastic tubes please use a plastic tube cutter or an appropriate cutter to cut the tubes.

2.1.2 Deburring and calibrating

The tube must then be carefully deburred – both internally and externally to remove all sharp edges and burrs. Copper tubes in annealed condition and plastic tubes should always be calibrated prior to installation.

2.1.3 Installation instructions

1. Cut tube with appropriate tube cutter.
2. Debur tube, inside and outside.
- 3 & 4. One of two methods can be implemented before making the joint.
 - a) The tube can be firmly inserted into the Conex Compression fitting without removing the capnut and compression ring. Care should be taken to ensure that the compression ring is in the correct position and that the tube makes firm contact with the tube stop in the body of the fitting.
 - b) The capnut and compression ring can be removed, located onto the tube in a logical sequence, and the tube fully inserted into the Conex Compression fitting.

Specified tube insertion depths in Table 6 are from front of capnut to bottom of tube stop.

5. Tightening the capnut to secure the joint causes the compression ring to change form, making a perfect metal x metal seal that actually indents the tube on both points of contact. A few drops of light oil applied to the screw thread before tightening the nut will reduce the load required to reach the number of turns. This is particularly applicable to the larger sizes and stainless steel applications. Refer to Table 4 for the correct number of turns to make the joint. This ensures a joint that is easily capable of withstanding pressures far in excess of those experienced in normal usage, proven by testing.

Note: Where necessary, insert a suitable tube liner before installation i.e. for soft copper tube or plastic pipe.

Fine threads have been avoided to prevent the danger of cross threading. Threads on the 8mm, 12mm and 15mm compression ends are equal to 1/4", 3/8" and 1/2" BSP in accordance with BS 2779/ISO 228. Other thread sizes are to BS 84 Whitworth.

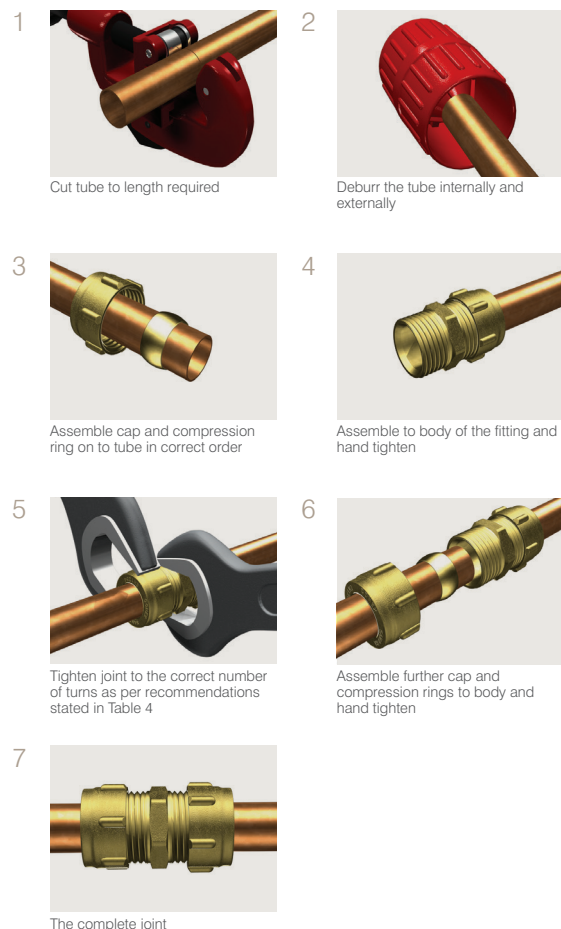

2.1.4. Complete the connection

Tighten the capnut with a suitable, commercially available tool, such as an adjustable flat faced spanner, to the number of turns specified in the table 4. Do not use a serrated jaw wrench.

Cone face connectors to EN 1254-2 (BS 864: Part 2) rely on a metal x metal seal and care should be taken to avoid damage prior to assembly. Should difficulty be experienced, the use of a WRAS listed sealant is permitted. Do not over tighten.

2.1.5 Threaded joints for water applications

The use of a WRAS listed sealant or tape (e.g. PTFE) is recommended for making joints on fittings with taper male threads. For making joints with parallel connector threads, a good quality washer should be used to suit the particular application .

Suitable WRAS approved washers are supplied with Conex tap connector fittings and these should be used.

Table 3: Spanner size for compression nut

Dimension	Spanner size
mm	
6	14
8	16
10	18
12	20
15	25
16	26
18	28
20	31
22	33
28	39
35	47
42	55
54	71
67	15
76	15
108	15

Note: When joining soft copper tube to EN 1057-R220 or plastic tubes to BS 7291, EN 15875 and EN 15876, it is essential that an appropriate tube liner is also fitted. Conex Compression joint makes a metal x metal seal which normally eliminates the need for jointing compounds and sealants. On larger sizes, particularly 54mm, it may be necessary to use an additional WRAS approved sealant. Jointing instructions, when using sealant, are available from our technical department.

Table 4: See below table for the turns required to tighten the Conex Compression joint after hand tightening.

Material	Tube/Pipe Specification	Size	6mm to 18mm	22mm	28mm to 54mm	
Copper	EN1057 - R250 (Half Hard)	No. of Turns	1 1/4	1	3/4	
	EN1057 - R290 (Hard)	No. of Turns	1	3/4	1/2	
	EN1057 - R220 (Annealed)	No. of Turns Liner Required SC1	1 1/4	1		
Stainless Steel	EN10312 (BS4127)	Size	6mm to 22mm	28mm	35mm to 54mm	
		No. of Turns	3/4	1/2	1/2	
Carbon Steel		Size	6mm to 22mm	28mm		
		No. of Turns	3/4	1/2		
Plastic Pipe	Polybutylene (PB)	Size	10mm	15mm	22mm	28mm
		No. of Turns	1 1/2	1 1/2	1 1/2	1 1/2
		Liner PP	C183031000PP	E203031000PP	G233031000PP	H293031000PP
	Cross Linked Polyethylene (PE-X)	Size	10mm	15mm	22mm	28mm
		No. of Turns	1 1/2	1 1/2	1 1/2	1 1/2
		Liner PP	C183031000PP	E183031000PP	G233031000PP	H293031000PP

Please note: For internal reducers the number of turns must be taken from the size of the connecting tubes not the size of the fitting.

2.2 Flange fittings – sizes 67-108mm

2.2.1 Ensure that the tube and fitting sizes are compatible. Then cut the tube end square but ensure tube retains its shape. The tube will then make even contact with the tube stop in the body of the fitting.

2.2.2 Remove any burrs from the tube, both inside and out.

2.2.3 One of two methods can be employed for making the joint.

a) The tube can be firmly inserted into the Conex Compression fitting without removing the compression plate and compression ring. Care should be taken to ensure that the compression ring is in the correct position and that the tube makes firm contact with the tube stop in the body of the fitting. The 3/8" BSW nuts are then tightened until hand tight and the same amount of all thread shows through each nut.

b) The compression plate and compression ring can be removed by first unscrewing the 3/8" BSW nuts. Then by locating the compression plate and compression ring onto the tube in logical sequence, the tube is inserted into the fitting, or fitting onto the tube, until positive contact is reached. The compression ring and compression plate are then correctly situated in their original position, the nuts are replaced and tightened until hand tight and the same amount of all thread shows through each nut.

2.2.4 In both cases the nuts are then further tightened a minimum of 2 full turns in increments of a 1/2 turn only, on each position in the sequence shown in Figure 2. To avoid over tightening the maximum number of turns is 2 1/2.

2.3 Internal reducers

Where dedicated fittings do not exist for reduction in tube-work, the reduction may be achieved with the use of internal reducers either as a three piece or one piece configuration. These are manufactured from DZR (dezincification resistant material CR) or gunmetal, thereby being resistant or immune to dezincification. They are suitable for use with our unique ribbed and octagon nut fittings.

Please Note: One piece reducers are not designed for use with plastic tubes. Only the three piece reducers - S68 can be used for plastic tubes. Please note: Internal reducers must not be used for gas applications and installations.

The minimum number of turns required is based on the reduced diameter. Thus for a 22mm x 15mm reducer, refer to Table 4 for the number of turns required for 15mm.

Reducers rely on a metal to metal seal and care should be taken to avoid damage prior to assembly. Should difficulty be experienced, the use of a WRAS listed sealant is permitted.

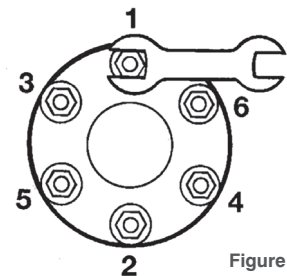

Figure 2

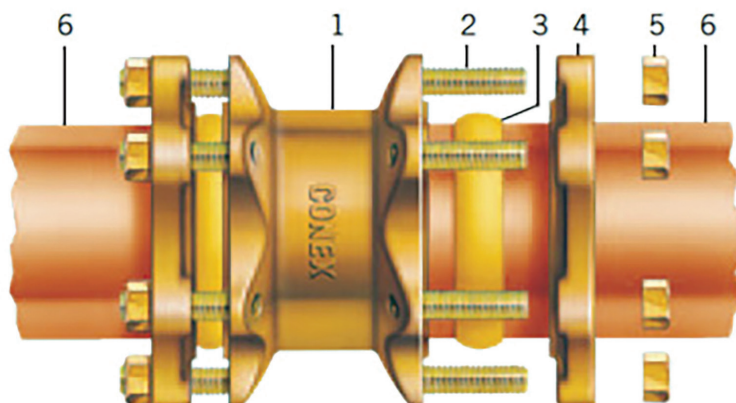

Figure 3

Note: The compression plate before and after correct assembly should be parallel to the face of the fitting body.

1. Fitting
2. Stud
3. Compression Ring
4. Compression Plate
5. Nut
6. Tube

2.4 Jointing instructions gas applications

There are four quick steps to fitting a quality compression joint that is guaranteed to last:

1. Make the joint in the same way as you would join water tubes following the standard catalogue instructions, but tighten the capnut 1/8 of a turn less than the specified number of turns once it is hand-tight.
2. Mark the position of the capnut in relation to the fitting. Then dismantle the joint.
3. Apply a thin smear of anaerobic sealant (in accordance with EN 751-1 approved for gas applications e.g. Loctite 542 or 577, Rood Foliac Super Red, etc) to the leading edge of the compression ring.
3. Re-assemble the joint and re-tighten the capnut as before to its marked position. Finally, tighten the capnut again by another 1/8 of a turn.

Table 5

Operating parameters		
Gases	Tube sizes	Max operating pressure at 30°
LPG & Natural Gases	6mm to 28mm	1.0 bar

6 2.4.1 Threaded joints for gas applications

An approved gas sealant must be used for making joints on fittings with taper male threads and female parallel threads.

Conex Compression fittings are fully tested and approved for gas applications and pass the high temperature leakage rate test at 650°C for 30 minutes. This criteria is fulfilled by the materials used and by the construction of the fitting.

Surface installations are possible, but the insertion behind studded walls and below ground is not permitted.

2.5 Minimum distances and insertion depths

Table 6

Dimension	Minimum distance	Minimum tube length	Insertion depth
	A	L	E
mm			
6	14	27	6.5
8	15	31	8
10	15	31	8
12	16	35	9.5
15	16	41	12.5
16	17	43	13
18	17	45	14
20	17	47	15
22	17	49	16
28	17	49	16
35	19	57	19
42	21	65	22
54	24	75	25.5

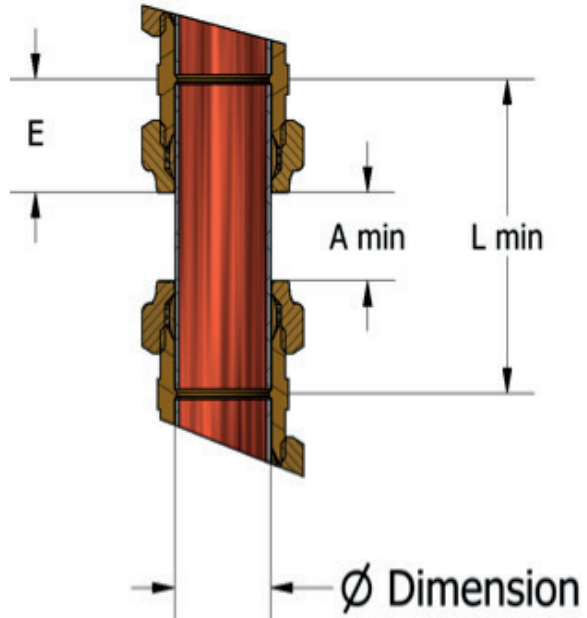

Figure 4

3.0 Applications

Table 7

Applications	Flow medium	Tube or pipe type				
		Copper	Stainless steel	Carbon steel	PB	PE-X
Drinking water applications EN 806	Drinking water in accordance with national drinking water regulations	√	√	x	√	√
Hot water and heating systems EN 12828	Heating water	√	√	√	√	√
Solar thermal systems EN 12975 / 12976	Water and water-glycol mixtures Mixing ratio max. 50/50%	√	√	√	x	x
Chilled water	Water and water-glycol mixtures. Mixing ratio max. 50/50%	√	√	√	x	x
Rainwater harvesting systems	Rainwater from cisterns	√	√	√	x	x
'Wet' fire extinguishing tube systems 14462	Firefighting water	√	√	√	x	x
Compressed air	Compressed air of all classes according to ISO 8573-1	√	√	√	x	x
Industrial and processing water	Reclaimed water $6.5 \leq \text{Ph} \leq 9.5$	√	√	√	x	x
Natural gas installations EN 1775	Combustion gases	√	√	√	x	x
Liquefied petroleum gas installations	Combustion gases	x	x	√	x	x
Fuel oil supply systems	Heating oil EL	√	x	x	x	x

4.0 Operating parameters

4.1 Operating temperature and pressures with metal tubes

The maximum operating temperatures and pressures are shown in table 9, based on EN 1254-2. Intermediate pressure ratings shall be determined from table 8 below or by extrapolation.

Table 8

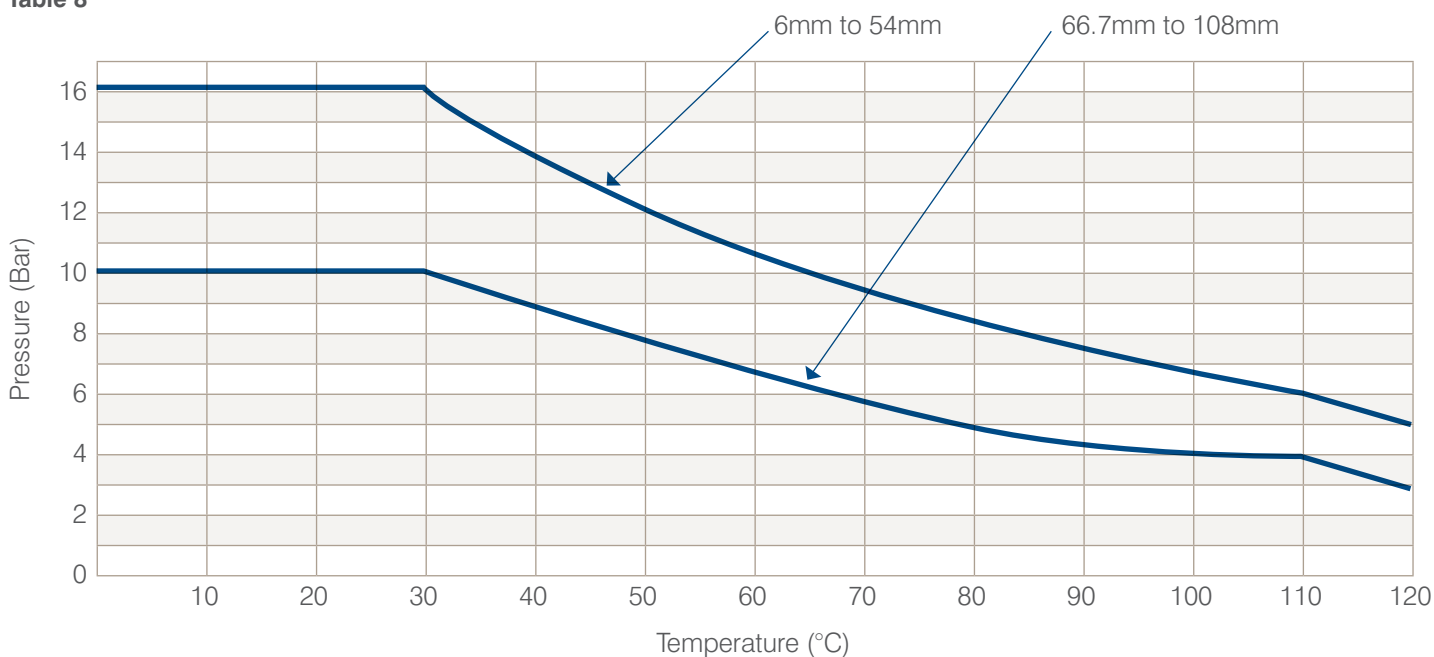

Table 9

Copper tube			
For use with	Tube sizes	Temps not exceeding	Max working pressures
	Ø mm	°C	Bar
Potable Water or Light Mineral Oils	6 to 54	30	16
		65	10
		95	7
		110	6
	66.7 to 108	30	10
		65	6
LPG, Natural Gas	8 to 28	30	1
Compressed Air	8 to 28	30	7
Solar	12 to 28	200	10

5.0 Other installations

5.1 Solar Installations

Conex Compression fittings have been tested at ERA Technology Ltd Surrey for use in Solar Installations for up to 200°C with 50/50 Glycol/Water. Sizes 12mm to 28mm. Please note: the number of turns of the capnut from hand tight must be 1-1/2 Turns.

5.2 Gas Installations

Special instructions required for the installation of gas

















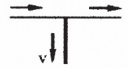
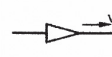

Conex Compression fittings are fully tested and approved for gas applications and pass the high temperature Leakage rate test at 650°C for 30 minutes. This criteria is fulfilled by the materials used and by the construction of the fitting.

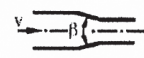
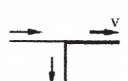
Surface installations are possible, but the insertion behind plaster and below ground is not permitted.

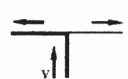

6. Loss coefficients

Table 10

Symbol	Designation	ζ	Application		Symbol	Designation	ζ	Application	
			DW	H				DW	H
	Angle or elbow reference value in accordance with DIN 1988 T3	0,70	X	X		Distributor outlet	0,5	X	X
	Angle 90° r/d = 0,5 (r/d = 1,2 = 1,0 with fittings = 2,0 complying with DIN EN 1254) = 3,0	1,0 0,35 0,20 0,15	X X X X	X X X X		Collective inlet	1,0	X	X
	Angle $\beta = 90^\circ$ $= 60^\circ$ $= 45^\circ$	1,3 0,8 0,4	X X X	X X X		Reservoir outlet	0,5	X	
	Crossover	0,5	X	X		Inlet	1,0	X	X
	Branch, square flow separation	1,3	X	X		Reducer	0,4	X	X
	Flow merging	0,9	X	X		Constriction β - constant = 30° 45° 60°	0,02 0,04 0,07	X X X	X X X
	Clearance at flow merging	0,3	X	X		Expansion β - constant = 10° 20° 30° 40°	0,10 0,15 0,20 0,20	X X X X	X X X X
	Clearance at flow merging	0,6	X	X		Expansion bends	1,0	X	X
	Counter-flow at flow merging	3,0	X	X		Compensator	2,0	X	X
	Counter-flow at flow separation	1,5	X	X		Compensator	2,0	X	X

Symbol	Designation	ζ	Application		Symbol	Designation	ζ	Application	
			DW	H				DW	H
	Branch, curved flow separation	0,9	X	X		Shut-off valve			
	Flow merging	0,4	X	X		Straight seat valve			
	Clearance at flow separation	0,3	X	X		DN15	10,0	X	X
	Clearance at flow merging	0,2	X	X		DN20	8,5	X	X
						DN25	7,0	X	X
						DN32	6,0	X	X
					DN40 to DN100	5,0	X	X	
						Angle seat valve			
	Angle valves				DN 15	3,5	X	X	
	DN 10	7,0	X	X	DN20	2,5	X	X	
	DN 15	4,0	X	X	DN 25 to DN50	2,0	X	X	
	DN 20	2,0	X	X	DN65	0,7	X	X	
	to DN 50	3,5	X	X					
DN 65 to DN 100	4,0	X	X						
	Diaphragm valves					Return flow inhibitor			
	DN 15	10,0	X	X		DN 15 to DN 20	7,7	X	
	DN 20	8,5	X	X		DN 25 to DN 40	4,3	X	
	DN 25	7,0	X	X		DN 50	3,8	X	
	to DN 32	6,0	X	X		DN 65 to DN 100	2,5	X	
DN 40 to DN 100	5,0	X	X						
	Shutter valves					Control valve with			
	Piston valves					return flow inhibitor			
	Ball valves					DN 20	6,0	X	
	DN 10 to DN 15	1,0	X	X		DN 25 to DN 50	5,0	X	
DN 20 to DN 25	0,5	X	X						
DN 32 to DN 150	0,3	X	X						
						Valve tapping			
						sleeve			
					DN 25 to DN 80	5,0	X		
						Boiler	2,5		X
						Heating radiator	2,5		X
						Panel radiator	3,0		X
	Pressure regulator fully open	30,0		X					

7.0 Pre-commissioning water systems

7.1 Water

In certain environments, particularly those containing corrosive media, stress corrosion cracking of Duplex brass and DZR compression fittings can occur. It is important to select the correct product for the application and to follow installation procedure to avoid corrosion or failure. For further information please see document on stress corrosion cracking.

7.2 Copper and copper alloy

Water systems containing tube and fittings in copper and copper alloy should have a regime of pre-commissioning that does not have any detrimental effect on the longevity of the system. Prior to this commissioning, the system should be pressure tested.

The chemicals used in the pre-commissioning, if incorrectly administered can have a serious effect on the systems' life, therefore the choice of chemicals is dependent on the particular site conditions and the materials used and the method(s) of construction.

Conex Bänninger do not recommend specific commercial products, but issue guidelines on a selection of chemicals available that are, if used correctly, suitable for copper and copper alloy fittings. In all cases these chemicals must be stored, handled, and ultimately disposed of (including flushing water) in a safe manner, taking into consideration current regulations such as COSHH, and the Health and Safety at Work Act in their current forms. The selection of chemical(s) may also be influenced by approval from the local water authorities, undertaking before chemicals are flushed or drained.

7.3 Chemical types, and their function(s) found in commercial products

Temporary mains supply(s) should be cleaned and chlorinated in accordance with BS 8558 before being used for system filling and flushing. Alternative sources such as fire hydrants should only be used with prior approval. If the permanent mains supply is used, connection should be made via a verifiable backflow preventer (RPZ valve assembly) in accordance with the Water Supply (Water Fittings) Regulations 1999.

Commercially available chemicals that contain the corrosion and scale inhibitors as constituents, listed in table 11, will depend on the components of the installed system. Their concentrations will depend on the system volumes, and dilution recommended by the supplier.

Table 11

Component	Inhibitor function
Nitrite	Corrosion inhibitor for ferrous metals
Nitrate	Corrosion inhibitor for aluminums
Molybdate	Corrosion inhibitor
Azoles	Corrosion inhibitor for copper and copper alloys
Phosphate	Corrosion inhibitor for steel
Polyphosphate	Scale and corrosion inhibitor. (Reverts to Orthophosphate)
Phosphonates	Scale and corrosion inhibitor
Silicates	Corrosion inhibitor for steel, copper alloys, and aluminums
Tannins	Film forming corrosion inhibitor and oxygen scavenger
Benzoate	Anodic inhibitor
Triethanolamine, monoethanolamine, alkylcarboxylates and substituted triazines	Organic film formers and corrosion inhibitors
Phosphono- and phosphino- carboxylic acids	Cathodic inhibitor and scale dispersant
Diethylhydroxylamine	Oxygen scavenger
Borate	pH buffer, biocide, and corrosion inhibitor

Ongoing water treatment should be provided by an accredited third party that specialises in that area of expertise.

If in doubt please contact our technical department:
technical@ibpgroup.com

8.0 Corrosion

7.4 Flushing of water installations

When the installation is complete, it is essential to flush the water system before use to remove dust, debris and flux residues, in accordance with national regulations and guidelines.

If the piping system is not used immediately after commissioning or flushed at regular intervals (of up to thirty days, depending on the characteristics of the water), it must be disinfected before use.

Caution: care must be taken to prevent the potential of legionella in systems with stagnant water.

7.5 Testing and commissioning drinking water installations

When the installation is complete, and after flushing, it should be slowly filled with water at an ambient temperature, with the highest draw-off point open to allow air to be expelled from the system. The installation should then be inspected for leaks and remedial action taken if necessary.

Caution: care must be taken to prevent the potential of legionella in systems with stagnant water.

7.6 Water softening

Hard water may be softened to avoid excessive deposits of scale in hot water services. However, a degree of scale is necessary to form the protective patina on copper tube.

When a new copper tube installation has a water softener fitted from day one, it is good practice to run the system for approximately three months with the softener by-pass open to allow untreated water into the system, and allow the patina to form.



8.1. Stress corrosion cracking

In certain environments, particularly those containing corrosive media, stress corrosion cracking of Duplex brass and DZR compression fittings can occur. It is important to select the correct product for the application and to follow installation procedure to avoid corrosion or failure. For further information please visit technical data under the literature page on www.conexbanninger.com.

8.2. Corrosion on copper and copper alloys

When metallic systems are pressure tested using water as a test media and subsequently drained down, this can affect the longevity of that system if precautions are not undertaken. Certain chemical processes rely on the flow of water to achieve a protective patina on the interior of the tube and fittings, stagnant areas can increase the potential for localised corrosion.

Systems containing copper tube with copper and copper alloy fittings generally have a high resistance to corrosion, however it is recommended when systems that have been hydrostatically pressure tested, they are fully drained down and blown out with dry air. Alternatively if this is impractical, the system should be left 'wet', and flushed at regular intervals prior to being commissioned to reduce carbon film cold water pitting, taking into account any precautions against freezing. This is of importance in new build housing when properties are not occupied for extended periods of time.

The use of commercial anti-corrosion chemicals is not to be used on potable water systems, due to the nature of these chemicals. Hydrostatic test pressures are generally 1.5 times the working pressure, and should be applied slowly to the system.

Caution: care must be taken to prevent the potential of legionella in systems with stagnant water.

All the above systems can be tested pneumatically, but the air must be clean, dry, and oil free (oil can have deleterious effects on EPDM seals in certain types of fittings, such as press and push fit). Care must also be taken with regards to pneumatic test pressures, 3.0 bar should be sufficient for most systems as air is more searching than water. Higher pressures are potentially dangerous due to the stored energy in compressed air/gas systems – HSE guidance should be observed.

If commercial leak detector aerosols are used to detect leaks, it is recommended the residue is washed off with clean, warm water.

9.0 The range

9.1 Compression range

Range code:

Brass
 DZR
 Red Brass

All sizes are in mm unless otherwise stated

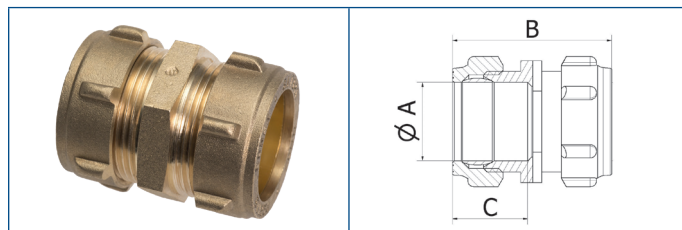

Straight Coupler - 301

Code	Fitting size	A	B	C
DD-1020301--	12	12	45	20
EE-1020301--	15	15	44	21
FF-1020301--	18	18	50	24
GG-1020301--	22	22	52	25
HH-1020301--	28	28	53	26
JJ-1020301--	35	35	62	30
AA-5020301--	6	6	32	16
BB-5020301--	8	8	39	17
CC-5020301--	10	10	41	18
DD-5020301--	12	12	45	20
EE-5020301--	15	15	44	21
FF-5020301--	18	18	50	24
GG-5020301--	22	22	52	25
HH-5020301--	28	28	53	26
JJ-5020301--	35	35	62	30
KK-5020301--	42	42	70	34
NN-5020301--	54	54	83	40

14

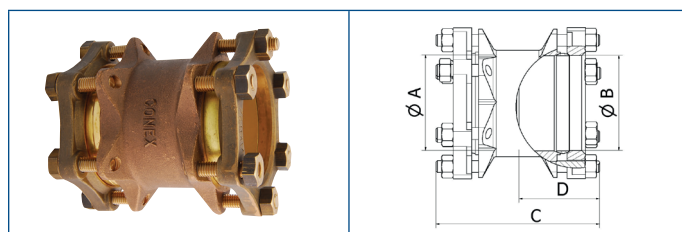

Straight Coupler - 301

			Across studs sizes	
QQ-2020301--	67	67	125	60
RR-2020301--	76	76	152	75
SS-2020301--	108	108	178	87

All sizes are in mm unless otherwise stated

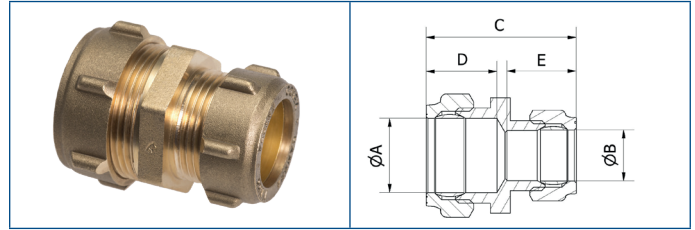

Reduced Straight Coupler - 301

Code	Fitting size	A	B	C	D	E
ED-1020301--	15 x 12	15	12	43	21	20
FD-1020301--	18 x 12	18	12	46	24	20
GE-1020301--	22 x 15	22	15	48	25	21
GF-1020301--	22 x 18	22	18	51	25	24
HG-1020301--	28 x 22	28	22	52	26	25
BA-5020301--	8 x 6	8	6	31	18	16
CB-5020301--	10 x 8	10	8	37	18	17
DB-5020301--	12 x 8	12	8	39	20	17
DC-5020301--	12 x 10	12	10	40	20	18
EB-5020301--	15 x 8	15	8	40	21	17
EC-5020301--	15 x 10	15	10	41	21	18
ED-5020301--	15 x 12	15	12	43	21	20
FE-5020301--	18 x 15	18	15	47	24	21
GE-5020301--	22 x 15	22	15	51	25	24
HG-5020301--	28 x 22	28	22	53	26	25
JH-5020301--	35 x 28	35	22	58	30	26

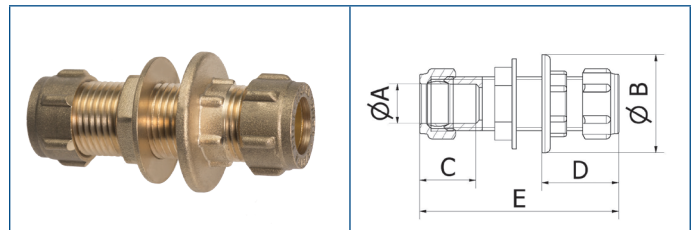

Straight Coupler Bulkhead - 301BH

Code	Fitting size	A	B	C	D	E
EE-1020301BH	15	15	38	20	25	77
GG-1020301BH	22	22	45	24	30	82

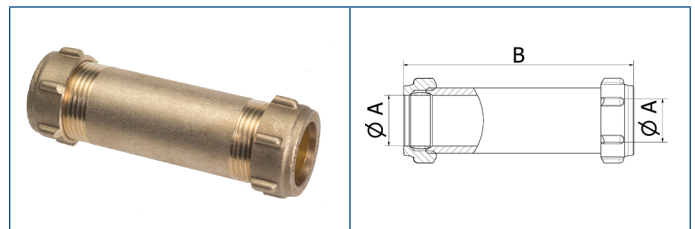

Straight Coupler Burst Tube Repair - 301BP

Code	Fitting size	A	B
DZB10CO301BP	12	12	100
EZB10CO301BP	15	15	100
FZB1020301BP	18	18	100
GZB10CO301BP	22	22	100

Range Code:

Brass
 DZR
 Red Brass

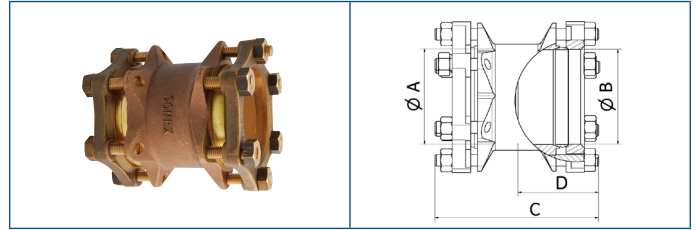

Imperial to Metric Straight Coupler - 301IM

Code	Fitting size	A	B	C	D
R302020301IM	76 x 3"	76	3"	160	80

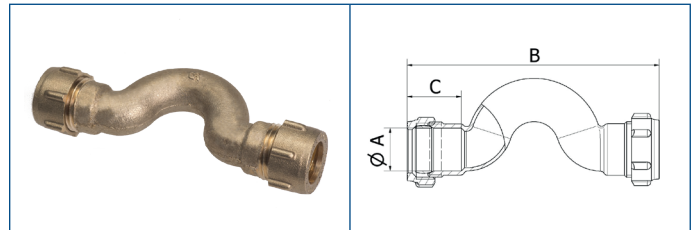

Crossover - 301CO

Code	Fitting size	A	B	C
EE-5020301CO	15	15	107	22
GG-5020301CO	22	22	127	25

All sizes are in mm unless otherwise stated

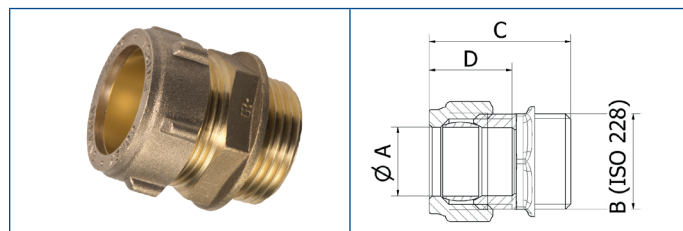
**Male Straight Coupler - 302**

Code	Fitting size	A	B	C	D
D011020302--	12 x 1/4"	12	1/4"	34	16
D021020302--	12 x 3/8"	12	3/8"	35	20
D031020302--	12 x 1/2"	12	1/2"	35	20
E011020302--	15 x 1/4"	15	1/4"	34	21
E021020302--	15 x 3/8"	15	3/8"	35	21
E031020302--	15 x 1/2"	15	1/2"	37	21
E041020302--	15 x 3/4"	15	3/4"	38	21
F031020302--	18 x 1/2"	18	1/2"	36	24
F041020302--	18 x 3/4"	18	3/4"	43	24
G031020302--	22 x 1/2"	22	1/2"	37	25
G041020302--	22 x 3/4"	22	3/4"	42	25
G051020302--	22 x 1"	22	1"	41	25
H051020302--	28 x 1"	28	1"	45	26
H061020302--	28 x 1 1/4"	28	1 1/4"	48	26
J061020302--	35 x 1 1/4"	35	1 1/4"	52	30
K071020302--	42 x 1 1/2"	42	1 1/2"	57	34
N081020302--	54 x 2"	54	2"	70	40
A605020302--	6 x 1/8"	6	1/8"	27	16
B015020302--	8 x 1/4"	8	1/4"	30	17
B025020302--	8 x 3/8"	8	3/8"	32	17
B035020302--	8 x 1/2"	8	1/2"	n/a	17
C015020302--	10 x 1/4"	10	1/4"	31	18
C025020302--	10 x 3/8"	10	3/8"	33	18
C035020302--	10 x 1/2"	10	1/2"	33	18
D025020302--	12 x 3/8"	12	3/8"	35	20
D035020302--	12 x 1/2"	12	1/2"	35	20
E025020302--	15 x 3/8"	15	3/8"	35	21
E035020302--	15 x 1/2"	15	1/2"	37	21
E045020302--	15 x 3/4"	15	3/4"	38	21
F035020302--	18 x 1/2"	18	1/2"	36	24
F045020302--	18 x 3/4"	18	3/4"	43	24
G035020302--	22 x 1/2"	22	1/2"	37	25
G045020302--	22 x 3/4"	22	3/4"	42	25
G055020302--	22 x 1"	22	1"	41	25
H055020302--	28 x 1"	28	1"	45	26
H045020302--	28 x 3/4"	28	3/4"	41	26
J055020302--	35 x 1"	35	1"	48	30
J065020302--	35 x 1 1/4"	35	1 1/4"	52	30
K075020302--	42 x 1 1/2"	42	1 1/2"	57	34
N085020302--	54 x 2"	54	2"	70	40
Q092020302--	67 x 2 1/2"	67	2 1/2"	86	64
R302020302--	76 x 3"	76	3"	101	79
S402020302--	108 x 4"	108	4"	138	86

Range Code:

Brass
 DZR
 Red Brass

Extended Male Straight Connector with Back Nut - 302B

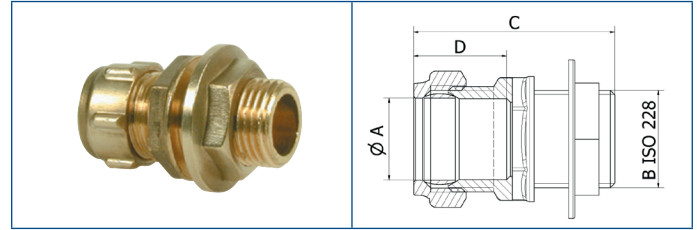

Code	Fitting size	A	B	C	D
E031020302B-	15 x 1/2"	15	1/2"	62	21
G041020302B-	22 x 3/4"	22	3/4"	72	25
H051020302B-	28 x 1"	28	1"	70	26
J061020302B-	35 x 1 1/4"	35	1 1/4"	62	30
K071020302B-	42 x 1 1/2"	42	1 1/2"	63	34
N081020302B-	54 x 2"	54	2"	69	40
Q092020302B-	67 x 2 1/2"	67	2 1/2"	146	60
R302020302B-	76 x 3"	76	3"	159	75

Extended Male Straight Connector with Back Nut - 302CB

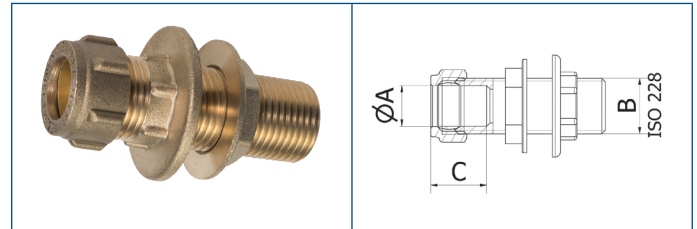

Code	Fitting size	A	B	C
E031020302CB	15 x 1/2 x 38	15	1/2"	21

Male Straight Connector - 302TA

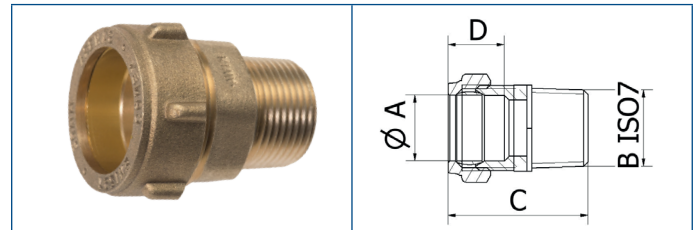

Code	Fitting size	A	B	C	D
C025020302TA	10 x 3/8"	10	3/8"	37	18
C035020302TA	10 x 1/2"	10	1/2"	41	18
D021020302TA	12 x 3/8"	12	3/8"	38	20
D031020302TA	12 x 1/2"	12	1/2"	42	20
E021020302TA	15 x 3/8"	15	3/8"	35	21
E031020302TA	15 x 1/2"	15	1/2"	43	21
E041020302TA	15 x 3/4"	15	3/4"	46	21
F031020302TA	18 x 1/2"	18	1/2"	43	24
F041020302TA	18 x 3/4"	18	3/4"	45	24
G031020302TA	22 x 1/2"	22	1/2"	45	25
G041020302TA	22 x 3/4"	22	3/4"	48	25
G051020302TA	22 x 1"	22	1"	51	25
H041020302TA	28 x 3/4"	28	3/4"	50	26
H051020302TA	28 x 1"	28	1"	53	26

All sizes are in mm unless otherwise stated

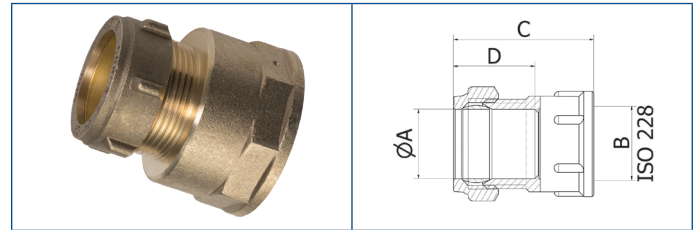
**Female Straight Connector - 303**

Code	Fitting size	A	B	C	D
D021020303--	12 x 3/8"	12	3/8	36	20
D031020303--	12 x 1/2"	12	1/2	39.5	20
E021020303--	15 x 3/8"	15	3/8	36.5	21
E031020303--	15 x 1/2"	15	1/2	39.5	21
E041020303--	15 x 3/4"	15	3/4	42.5	21
E051020303--	15 x 1"	15	1	43.5	21
F031020303--	18 x 1/2"	15	1/2	41.5	24
F041020303--	18 x 3/4"	18	3/4	42.5	24
G031020303--	22 x 1/2"	18	1/2	43	25
G041020303--	22 x 3/4"	22	3/4	43	25
G051020303--	22 x 1"	22	1	48	25
H051020303--	28 x 1"	28	1	48	26
H061020303--	28 x 1 1/4"	28	1 1/4	51	26
B015020303--	8 x 1/4"	8	1/4"	32.5	17
B025020303--	8 x 3/8"	8	3/8"	33.5	17
B035020303--	8 x 1/2"	8	1/2"	36.5	17
C015020303--	10 x 1/4"	10	1/4"	34	18
C025020303--	10 x 3/8"	10	3/8"	34	18
C035020303--	10 x 1/2"	10	1/2"	37	18
D025020303--	12 x 3/8"	12	3/8"	36	20
D035020303--	12 x 1/2"	12	1/2"	39.5	20
E025020303--	15 x 3/8"	15	3/8"	36.5	21
E035020303--	15 x 1/2"	15	1/2"	39.5	21
E045020303--	15 x 3/4"	15	3/4"	42.5	21
F035020303--	18 x 1/2"	18	1/2"	41.5	24
F045020303--	18 x 3/4"	18	3/4"	42.5	24
G045020303--	22 x 3/4"	22	3/4"	43.5	25
G055020303--	22 x 1"	22	1"	49	25
H045020303--	28 x 3/4"	28	3/4"	43	26
H055020303--	28 x 1"	28	1"	48	26
J055020303--	35 x 1"	35	1"	56	30
J065020303--	35 x 1 1/4"	35	1 1/4"	57	30
K075020303--	42 x 1 1/2"	42	1 1/2"	63	34
N085020303--	54 x 2"	54	2"	72	40
Q092020303--	67 x 2 1/2"	67	2 1/2"	93	64
R302020303--	76 x 3"	76	3"	112	79

Range Code:

Brass
 DZR
 Red Brass

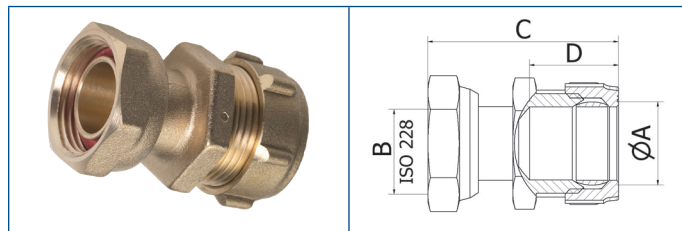

Straight Tap Connector Max 60°C - 303SF

Code	Fitting size	A	B	C	D
E031020303SF	15 x 1/2"	15	1/2"	35	21
G041020303SF	22 x 3/4"	22	3/4"	39	25
E035020303SF	15 x 1/2"	15	1/2"	35	21
E045020303SF	15 x 3/4"	15	3/4"	36	21
G045020303SF	22 x 3/4"	22	3/4"	39	25

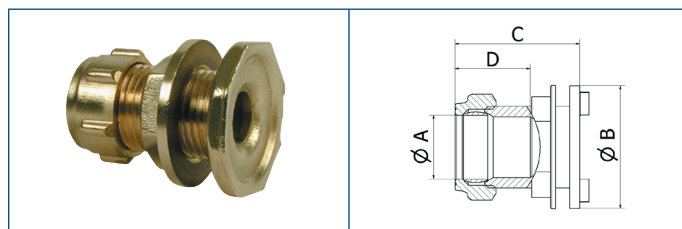

Tank Connector - 321

Code	Fitting size	A	B	C	D
E--1020321--	15	15	35	49	21
G--1020321--	22	22	43	46	25
H--1020321--	28	28	49	48	26
J--1020321--	35	35	57	46	30
K--5020321--	42	42	63	49	34
N--5020321--	54	54	82	73	40
H--5020321--	28	28	49	48	25



Female Straight Connector for Pillar Taps - 303ST (Short thread)

Code	Fitting size	A	B	C	D
E031020303ST	15	15	1/2"	33	21
E041020303ST	15	15	3/4"	33	21
G041020303ST	22	22	3/4"	33	25

All sizes are in mm unless otherwise stated

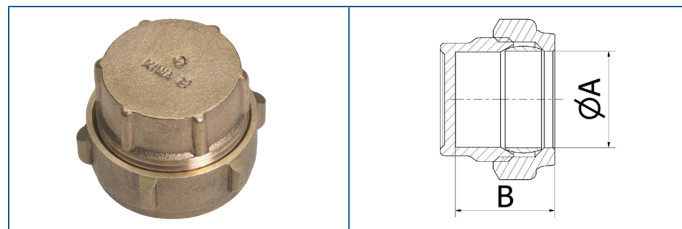

Stop End - 323

Code	Fitting size	A	B
B--1020323--	8	8	19
D--1020323--	12	12	22
E--1020323--	15	15	26
G--1020323--	22	22	27
H--1020323--	28	28	31
B--5020323--	8	8	22
C--5020323--	10	10	22
D--5020323--	12	12	25
E--5020323--	15	15	26
F--5020323--	18	18	29
G--5020323--	22	22	27
H--5020323--	28	28	40
J--5020323--	35	35	35
K--5020323--	42	42	37
N--5020323--	54	54	50

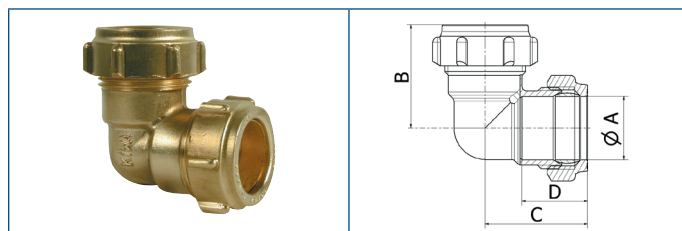

Elbow - 401

Code	Fitting size	A	B	C	D
DD-1020401--	12	12	29	29	20
EE-1020401--	15	15	31	31	21
FF-1020401--	18	18	35	35	24
GG-1020401--	22	22	37	37	25
HH-1020401--	28	28	42	42	26
JJ-1020401--	35	35	48	48	30
KK-1020401--	42	42	56	56	34
NN-1020401--	54	54	69	69	40
AA-5020401--	6	6	23	23	23
BB-5020401--	8	8	24	25	17
CC-5020401--	10	10	28	28	18
DD-5020401--	12	12	29	30	20
EE-5020401--	15	15	31	32	21
FF-5020401--	18	18	35	35	29
GG-5020401--	22	22	37	40	25
HH-5020401--	28	28	42	42	26
JJ-5020401--	35	35	48	48	30
KK-5020401--	42	42	56	56	34
NN-2020401--	54	54	69	69	40
QQ-2020401--	67	67	102	102	64
RR-2020401--	76	76	114	114	79

Range Code:

Brass
 DZR
 Red Brass

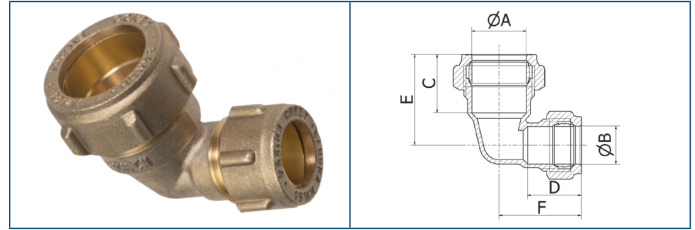

Reduced Elbow - 401

Code	Fitting size	A	B	C	D	E	F
ED-1020401--	15 x 12	15	12	21	20	28	26
FE-1020401--	18 x 15	18	15	24	21	34	33
GE-1020401--	22 x 15	22	15	25	21	34	25
DC-5020401--	12 x 10	12	10	20	18	28	22
EC-5020401--	15 x 10	15	10	21	19	31	30
GE-5020401--	22 x 15	22	15	25	21	34	31
HE-5020401--	28 x 15	28	15	26	21	38	34
HG-5020401--	28 x 22	28	22	26	25	38	39

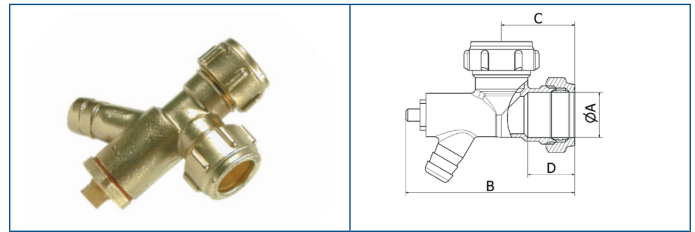

Elbow with Drain Tap - 401DA

Code	Fitting size	A	B	C	D
EE-1020401DA	15	15	81	31	22
GG-1020401DA	22	22	91	37	25
HH-1020401DA	28	28	97	42	26

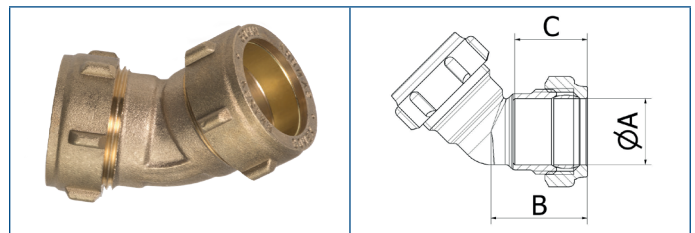

Obtuse Elbow - 401/O

Code	Fitting size	A	B	C
EE-1020401/O	15	15	24	21
GG-1020401/O	22	22	28	25
HH-1020401/O	28	28	30	26

All sizes are in mm unless otherwise stated

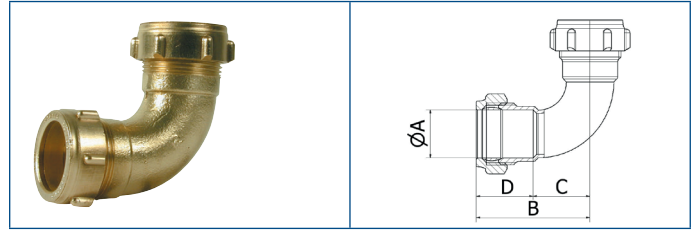

Slow Bend - 401S

Code	Fitting size	A	B	C	D
EE-5020401S-	15	15	41	19	22
GG-5020401S-	22	22	46	22	24
HH-5020401S-	28	28	53	27	26

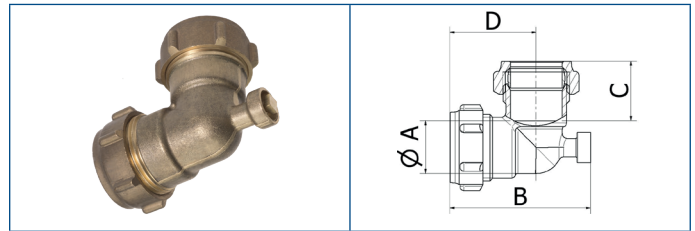

Elbow with Air Vent - 401V

Code	Fitting size	A	B	C	D
EE-1020401V-	15	15	52	22	
GG-1020401V-	22	22	60	25	

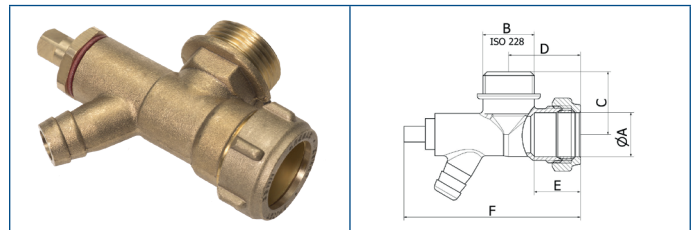

Male Elbow with Drain Tap - 402DA

Code	Fitting size	A	B	C	D	E	F
G041020402DA	22 x 3/4"	22	3/4"	33	38	25	91

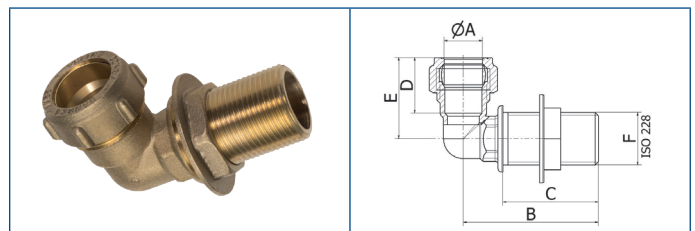

Extended Male Elbow with Back Nut - 402CB

Code	Fitting size	A	B	C	D	E	F
E031020402CB	15 x 1/2" x 38	15	1/2"	38	21	34	54
G041020402CB	22 x 1/2" x 38	22	1/2"	38	25	38	59

Range Code:

Brass
 DZR
 Red Brass

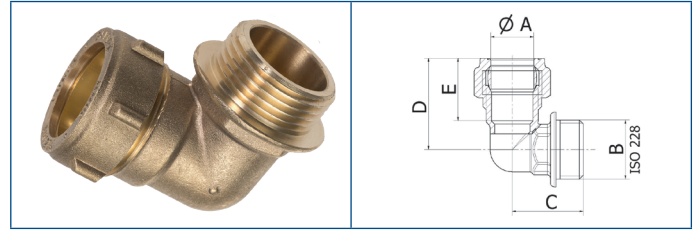

Male Elbow - 402

Code	Fitting size	A	B	C	D	E
E031020402--	15 x 1/2"	15	1/2"	24	33	21
E041020402--	15 x 3/4"		3/4"	29	35	21
F031020402--	18 x 1/2"	18	1/2"	27	37	24
G041020402--	22 x 3/4"	22	3/4"	31	43	25
G051020402--	22 x 1"	22	1"	38	43	25
H041020402--	28 x 3/4"	28	3/4"	37	39	26
B015020402--	8 x 1/4"	8	1/4"	20	27	17
C025020402--	10 x 3/8"	10	3/8"	23	30	18
C035020402--	10 x 1/2"	10	1/2"	24	32	18
D025020402--	12 x 3/8"	12	3/8"	23	30	20
D035020402--	12 x 1/2"	12	1/2"	24	34	20
E025020402--	15 x 3/8"	15	3/8"	23	30	21
E035020402--	15 x 1/2"	15	1/2"	24	33	21
E045020402--	15 x 3/4"	15	3/4"	29	35	21
F035020402--	18 x 1/2"	18	1/2"	27	37	24
F045020402--	18 x 3/4"	18	3/4"	29	37	24
G035020402--	22 x 1/2"	22	1/2"	30	40	25
G045020402--	22 x 3/4"	22	3/4"	31	38	25
H055020402--	28 x 1"	28	1"	38	43	26
J065020402--	35 x 1 1/4"	35	1 1/4"	45	49	30
K075020402--	42 x 1 1/2"	42	1 1/2"	17	56	34
N082020402--	54 x 2"	54	2"	18	69	40
Q092020402--	67 x 2.1/2"	67	2 1/2"	83	109	60

24

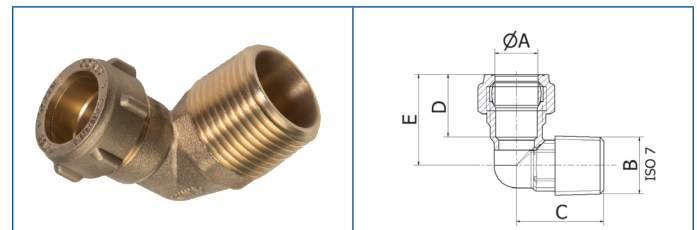

Male Elbow Taper - 402TA

Code	Fitting size	A	B	C	D	E
D021020402TA	12 x 3/8"	12	3/8"	31	20	27
D031020402TA	12 x 1/2"	12	1/2"	33	20	31
T031020402TA	14 x 1/2"	14	1/2"	35	21	31
E021020402TA	15 x 3/8"	15	3/8"	29	21	30
E031020402TA	15 x 1/2"	15	1/2"	31	21	33
E041020402TA	15 x 3/4"	15	3/4"	34	21	35
U031020402TA	16 x 1/2"	16	1/2"	34	22	35
U041020402TA	16 x 3/4"	16	3/4"	37	22	38
F031020402TA	18 x 1/2"	18	1/2"	35	24	36
F041020402TA	18 x 3/4"	18	3/4"	36	24	34
G041020402TA	22 x 3/4"	22	3/4"	37	25	38
G051020402TA	22 x 1"	22	1"	42	25	40
H051020402TA	28 x 1"	28	1"	45	26	43
C035020402TA	10 x 1/2"	10	1/2"	31	18	32

All sizes are in mm unless otherwise stated

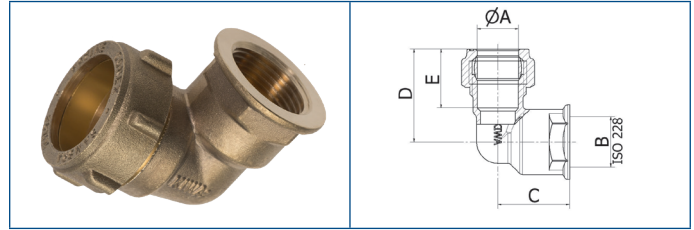

Female Elbow - 403

Code	Fitting size	A	B	C	D	E
D031020403--	12 x 1/2"	12	1/2"	22.5	33	20
E031020403--	15 x 1/2"	15	1/2"	15	34	21
E041020403--	15 x 3/4"	15	3/4"	25.5	35.5	21
F031020403--	18 x 1/2"	18	1/2"	26	36	24
F041020403--	18 x 3/4"	18	3/4"	30	40	24
G031020403--	22 x 1/2"	22	1/2"	25	37	25
G041020403--	22 x 3/4"	22	3/4"	29	39	25
G051020403--	22 x 1"	22	1"	31	43	25
H041020403--	28 x 3/4"	28	3/4"	33	40	26
H051020403--	28 x 1"	28	1"	35	44	26
K071020403--	42 x 1 1/2"	42	1 1/2"	48.5	55.5	34
B015020403--	8 x 1/4"	8	1/4"	17	27	17
C025020403--	10 x 3/8"	10	3/8"	19	29	18
C035020403--	10 x 1/2"	10	1/2"	23	33	18
D025020403--	12 x 3/8"	12	3/8"	19	30.5	20
D035020403--	12 x 1/2"	12	1/2"	22.5	33	20
E025020403--	15 x 3/8"	15	3/8"	21.5	32	20
E035020403--	15 x 1/2"	15	1/2"	23.5	34.5	21
E045020403--	15 x 3/4"	15	3/4"	25.5	35.5	21
F045020403--	18 x 3/4"	18	3/4"	30	40	24
G035020403--	22 x 1/2"	22	1/2"	25	37	24
G045020403--	22 x 3/4"	22	3/4"	28.5	39.5	25
H055020403--	28 x 1"	28	1"	30.5	42.5	26
J065020403--	35 x 1 1/4"	35	1 1/4"	35	44	30
K072020403--	42 x 1 1/2"	42	1 1/2"	48.5	55.5	34
N082020403--	54 x 2"	54	2"	55.5	70	40

25

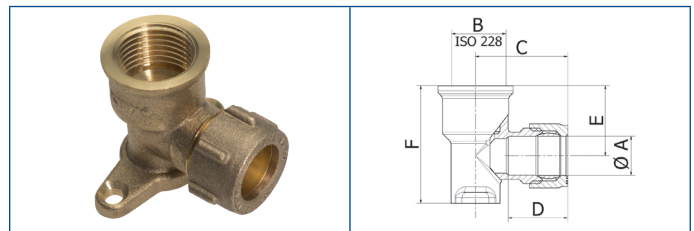

Female Wall Plate Elbow 2 Hole - 403W

Code	Fitting size	A	B	C	D	E	F
D031020403W-	12 x 1/2"	12	1/2"	33	18	25	38
T031020403W-	14 x 1/2"	14	1/2"	44	21	24	42
E031020403W-	15 x 1/2"	15	1/2"	44	21	24	42
E035020403W-	15 x 1/2"	15	1/2"	44	21	24	42

Range Code:

Brass
 DZR
 Red Brass

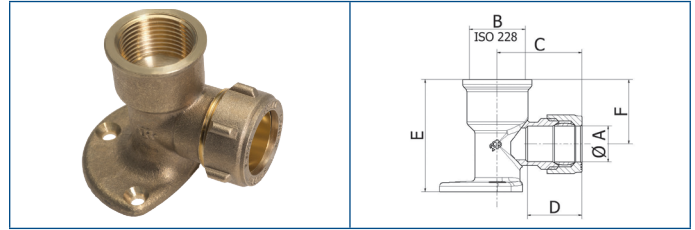

Female Wall Plate Elbow 3 Hole - 403WL

Code	Fitting size	A	B	C	D	E	F
E031020403WL	15 x 1/2"	15	1/2"	34	21	45	25
U031020403WL	16 x 1/2"	16	1/2"	34	21	45	25
F031020403WL	18 x 1/2"	18	1/2"	37	24	43	30
G031020403WL	22 x 1/2"	22	1/2"	38	25	47	35
H051020403WL	28 x 1"	28	1/2"	44	26	65	40
C035020403WL	10 x 1/2"	10	1/2"	34	18	38	23
D035020403WL	12 x 1/2"	12	1/2"	33	20	38	23
E035020403WL	15 x 1/2"	15	1/2"	34	21	45	25
G0450CO403WL	22 x 3/4"	22	3/4"	38	24	54	32
H051020403WL	28 x 1"	28	1"	44	26	65	40

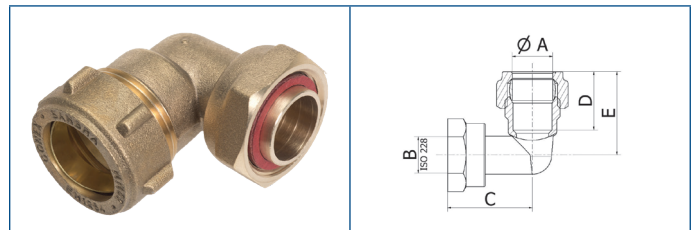

Bent Tap Connector - 403SF

Code	Fitting size	A	B	C	D	E
E031020403SF	15 x 1/2"	15	1/2"	25	21	31
G031020403SF	22 x 1/2"	22	1/2"	29	25	33
G041020403SF	22 x 3/4"	22	3/4"	30	25	36
E035020403SF	15 x 1/2"	15	1/2"	25	21	31

All sizes are in mm unless otherwise stated

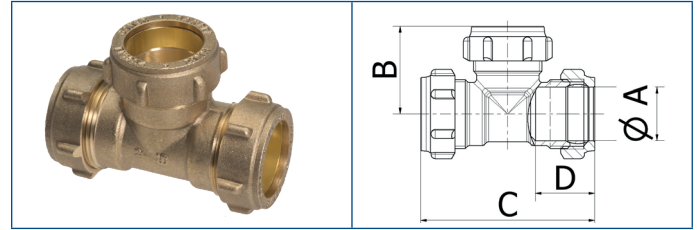
**Equal Tee - 601EQ**

Code	Fitting size	A	B	C	D
DDD1020601EQ	12	12	29	58	20
TTT1020601EQ	14	14	31	63	21
EEE1020601EQ	15	15	31	63	21
FFF1020601EQ	18	18	33	66	24
GGG1020601EQ	22	22	36	73	25
HHH1020601EQ	28	28	42	83	26
AAA5020601EQ	6	6	22	45	15
BBB5020601EQ	8	8	25	50	17
CCC5020601EQ	10	10	28	56	18
DDD5020601EQ	12	12	29	58	20
EEE5020601EQ	15	15	31	63	21
FFF5020601EQ	18	18	33	66	24
GGG5020601EQ	22	22	36	73	26
HHH5020601EQ	28	28	42	83	26
JJJ5020601EQ	35	35	53	106	30
KKK5020601EQ	42	42	62	123	34
NNN2020601EQ	54	54	63	124	40
QQQ2020601EQ	67	67	98	196	64
RRR2020601EQ	76	76	118	240	79

Range Code:

Brass
 DZR
 Red Brass

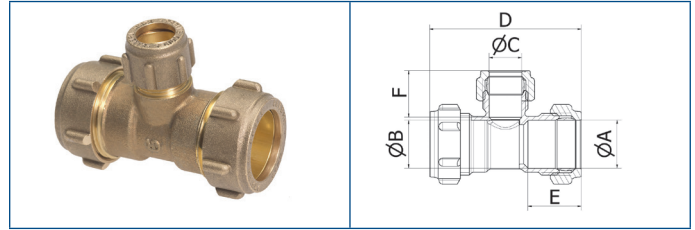

Tee Reduced Branch - 601RB

Code	Fitting size	A	B	C	D	E	F
GGE1020601--	22 x 22 x 15	22	22	15	69	25	21
HHE1020601--	28 x 28 x 15	28	28	15	68	26	21
HHG1020601--	28 x 28 x 22	28	28	22	76	26	25
NNE1020601--	54 x 54 x 15	54	54	15	114	40	21
NNG1020601--	54 x 54 x 22	54	54	22	114	40	25
NNH1020601--	54 x 54 x 28	54	54	28	114	40	26
DDC5020601--	12 x 12 x 10	12	12	10	58	20	18
EEC5020601--	15 x 15 x 10	15	15	10	63	21	18
EED5020601--	15 x 15 x 12	15	15	12	64	21	20
FFD5020601--	18 x 18 x 12	18	18	12	61	24	20
FFE5020601--	18 x 18 x 15	18	18	15	68	24	21
GGD5020601--	22 x 22 x 12	22	22	12	70	25	20
GGE5020601--	22 x 22 x 15	22	22	15	70	25	21
GGF5020601--	22 x 22 x 18	22	22	18	73	25	24
HHE5020601--	28 x 28 x 15	28	28	15	68	26	24
HHG5020601--	28 x 28 x 22	28	28	22	76	26	25
JJE5020601--	35 x 35 x 15	35	35	15	82	30	24
JJG5020601--	35 x 35 x 22	35	35	22	82	30	25
JJH5020601--	35 x 35 x 28	35	35	28	89	30	26
KKE5020601--	42 x 42 x 15	42	42	15	92	34	24
KKG5020601--	42 x 42 x 22	42	42	22	92	34	25
KKH5020601--	42 x 42 x 28	42	42	28	106	34	26
KKJ5020601--	42 x 42 x 35	42	42	35	106	34	30
NNK5020601--	54 x 54 x 42	42	42	54	37	40	34
NNJ2020601--	54 x 54 x 35	54	54	35	114	40	30
NNK2020601--	54 x 54 x 42	54	54	42	118	40	34
QQH2020601--	67 x 67 x 28	67	67	28	151	64	25
QQK2020601--	67 x 67 x 42	67	67	42	167	64	34
QQN2020601--	67 x 67 x 54	67	67	54	177	64	40
RRH2020601--	76 x 76 x 28	76	76	28	183	79	25
RRN2020601--	76 x 76 x 54	76	76	54	209	79	40

All sizes are in mm unless otherwise stated

Three-way Equal Tee - 601C

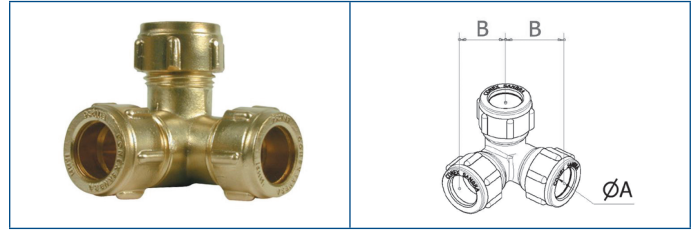

Code	Fitting size	A	B
EEE50CO601C-	15 x 15 x 15	15	34
GGG50CO601C-	22 x 22 x 22	22	37

Tee Reduced End - 601RE

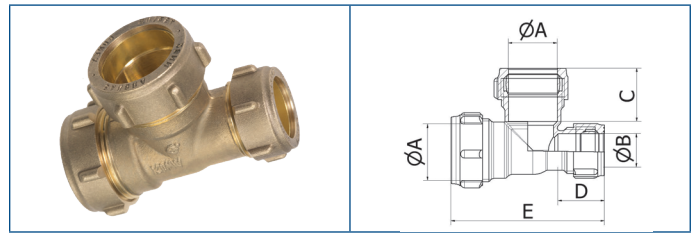

Code	Fitting size	A	B	C	D	E	F
GEG1020601--	22 x 15 x 22	22	15	24	21	70	37
HEH1020601--	28 x 15 x 28	22	15	26	21	81	42
GEG5020601--	22 x 15 x 22	22	15	24	21	70	37
HGH5020601--	28 x 22 x 28	22	15	26	21	81	42

Tee Reduced End and Branch - 601REB

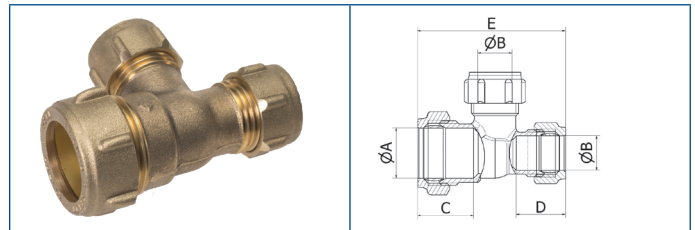

Code	Fitting size	A	B	C	D	E
GEE1020601--	22 x 15 x 15	22	15	25	21	65
EDD50CO601--	15 x 12 x 12	15	12	21	18	64
GEE5020601--	22 x 15 x 15	22	15	25	21	65
HGG50CO601--	28 x 22 x 22	28	22	26	25	75

Tee Reduced Both Ends - 601REE

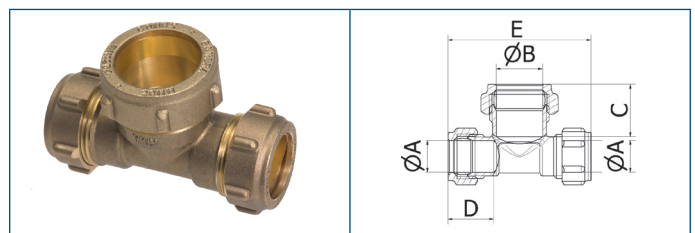

Code	Fitting size	A	B	C	D	E
EEG1020601-	15 x 15 x 22	15	15	25	21	70
GGH5020601--	22 x 22 x 28	22	22	26	25	82

Range Code:

Brass
 DZR
 Red Brass

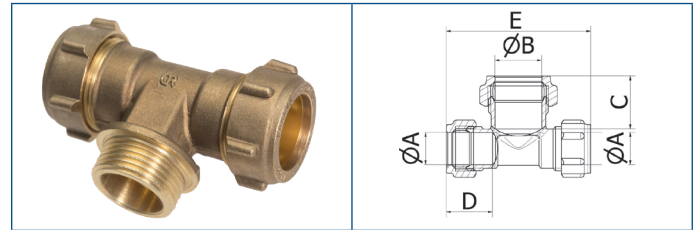

Tee with Male Branch - 615

Code	Fitting size	A	B	C	D	E
EE350CO615--	15 x 1/2" x 15	15	1/2"	26	21	68
GG350CO615--	22 x 1/2" x 22	22	1/2"	31	25	73
GG450CO615--	22 x 3/4" x 22	22	3/4"	33	25	77

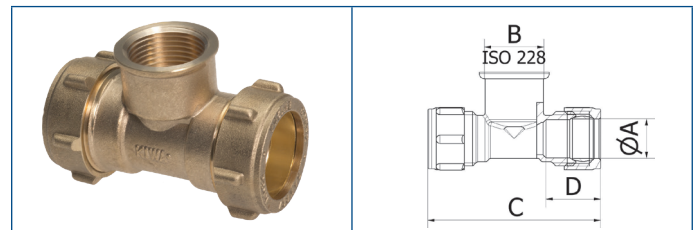

Tee with Female Branch - 617

Code	Fitting size	A	B	C	D
TT31020617--	14 x 14 x 1/2"	14	1/2"	62	21
EE11020617--	15 x 15 x 1/4"	15	1/4"	63	21
EE31020617--	15 x 15 x 1/2"	15	1/2"	66	21
EE41020617--	15 x 15 x 3/4"	15	3/4"	74	21
FF31020617--	18 x 18 x 1/2"	18	1/2"	72	24
GG31020617--	22 x 22 x 1/2"	22	1/2"	73	25
GG51020617--	22 x 22 x 1"	22	1"	88	25
HH41020617--	28 x 28 x 3/4"	28	3/4"	80	26
DD25020617--	12 x 12 x 3/8"	12	3/8"	61	20.5
DD35020617--	12 x 12 x 1/2"	12	1/2"	67	24
EE35020617--	15 x 15 x 1/2"	15	1/2"	66	21
GG35020617--	22 x 22 x 1/2"	22	1/2"	73	25
GG45020617--	22 x 22 x 3/4"	22	3/4"	78	25
HH35020617--	28 x 28 x 1/2"	28	1/2"	77	26
HH55020617--	28 x 28 x 1"	28	1"	86	26

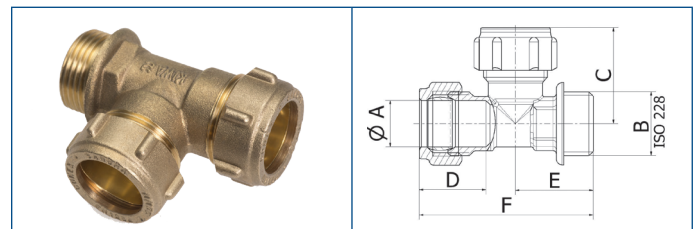

Tee with Male End - 631

Code	Fitting size	A	B	C	D	E	F
E3E5020631--	15 x 1/2" x 15	15	1/2"	34	21	26	48
G4G5020631--	22 x 3/4" x 22	22	3/4"	37	25	33	70

All sizes are in mm unless otherwise stated

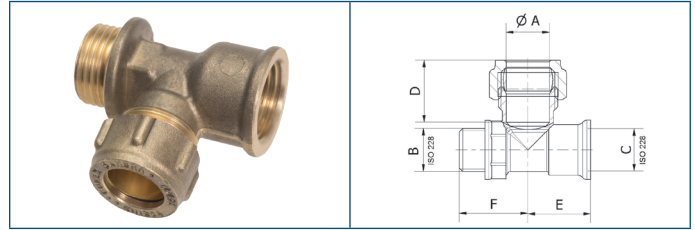

Tee with Male and Female Ends - 645

Code	Fitting size	A	B	C	D	E	F
33E1020645--	1/2 x 1/2 x 15	15	1/2"	1/2"	21	23	25

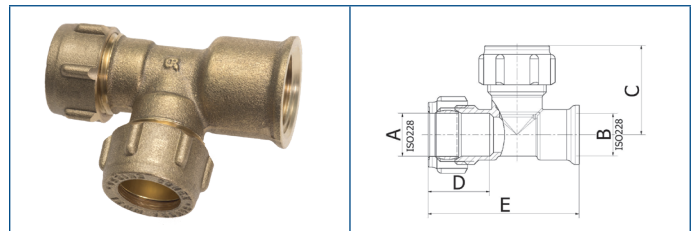

Tee with Female End - 684

Code	Fitting size	A	B	C	D	E
G3G1020684--	22 x 1/2" x 22	22	1/2"	22	36	60.5
G4G1020684--	22 x 3/4" x 22	22	3/4"	22	40	66
E3E5020684--	15 x 1/2" x 15	15	1/2"	15	33	35

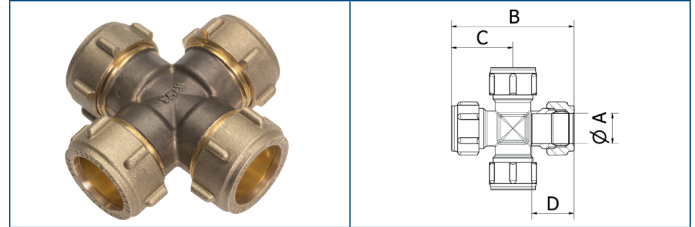

Cross - Equal - 901

Code	Fitting size	A	B	C	D
EEEE1020901-	15 x 15 x 15 x 15	15	63	32	21
GGGG1020901	22 x 22 x 22 x 22	22	74	37	25

Range Code:

Brass
 DZR
 Red Brass

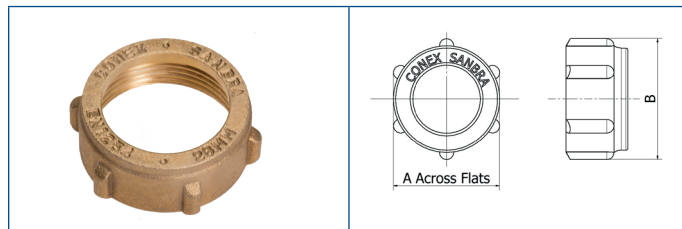

Capnut - 63

Code	Fitting size	A	B
A--1020063--	6	13	15
B--1020063--	8	16	18
C--1020063--	10	18	21
D--1020063--	12	20	22
E--1020063--	15	24	27
F--1020063--	18	27	31
G--1020063--	22	32	37
H--1020063--	28	39	45
J--1020063--	35	47	50
K--1020063--	42	55	59
N--1020063--	54	70	76

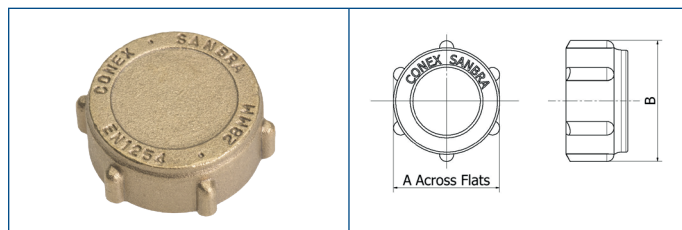

Blank Capnut - 63B

Code	Fitting size	A	B
B--1020063B-	8	16	18
C--1020063B-	10	18	21
D--1020063B-	12	20	22
E--1020063B-	15	24	27
G--1020063B-	22	32	37
H--1020063B-	28	39	45
J--1020063B-	35	47	50
K--1020063B-	42	55	59
N--1020063B-	54	70	76



Compression Ring (Imperial) - 65

Code	Fitting size	A	B
04-1020065--	3/4"	3/4" (24)	8.5
05-1020065--	1"	1" (31)	8.5
06-1020065--	1 1/4"	1 1/4" (38)	9.5
30-1020065--	3"	3" (80)	15

All sizes are in mm unless otherwise stated

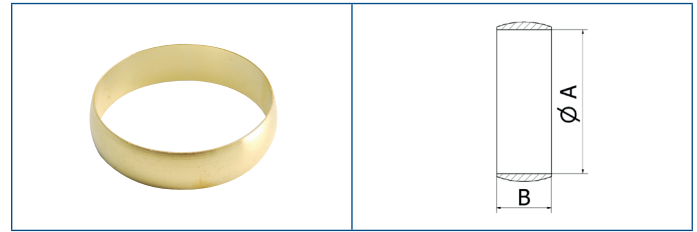

Compression Ring - 65

Code	Fitting size	A	B
A--10CO065--	6	6	6.2
B--10CO065--	8	8	6.2
C--10CO065--	10	10	7.2
D--10CO065--	12	12	8
E--10CO065--	15	15	8
U--10CO065--	16	16	8
F--10CO065--	18	18	8
V--1020065--	20	20	8
G--10CO065--	22	22	9
H--10CO065--	28	28	9
J--1020065--	35	35	10
K--1020065--	42	42	10
N--1020065--	54	54	13
Q--1020065--	67	67	14
R--1020065--	76	76	15
S--1020065--	108	108	17

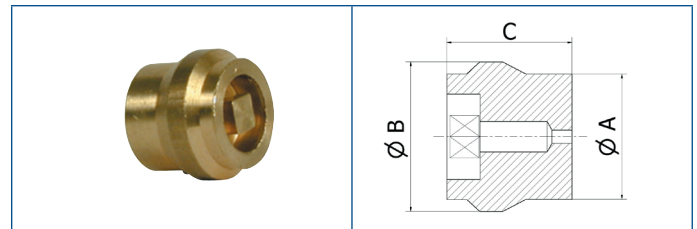

Air Vent - 63V

Code	Fitting size	A	B	C
E--1020063V	15	15	18	13

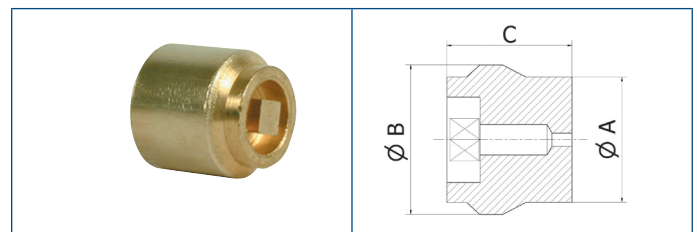

Terminal Air Vent - 63TV

Code	Fitting size	A	B	C
E--1020063TV	15	15	12	17.5

Range Code:

Brass
 DZR
 Red Brass

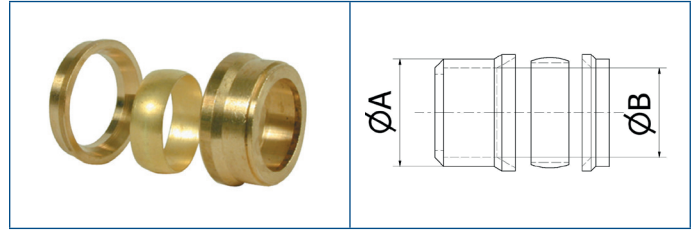

Internal Reducer S68

Code	Fitting size	A	B
CB-5020068--	10 x 8	10	8
DB-5020068--	12 x 8	12	8
DC-5020068--	12 x 10	12	10
EB-5020068--	15 x 8	15	8
EC-5020068--	15 x 10	15	10
ED-5020068--	15 x 12	15	12
FD-5020068--	18 x 12	18	12
FE-5020068--	18 x 15	18	15
GD-5020068--	22 x 12	22	22
GE-5020068--	22 x 15	22	15
GF-5020068--	22 x 18	22	18
HE-5020068--	28 x 15	28	15
HF-5020068--	28 x 18	28	18
HG-5020068--	28 x 22	28	22
JE-5020068--	35 x 15	35	15
JG-5020068--	35 x 22	35	22
JH-5020068--	35 x 28	35	28
KE-5020068--	42 x 15	42	15
KG-5020068--	42 x 22	42	22
KH-5020068--	42 x 28	42	28
KJ-5020068--	42 x 35	42	35
NE-5020068--	54 x 15	54	15
NG-5020068--	54 x 22	54	22
NH-5020068--	54 x 28	54	28
NJ-5020068--	54 x 35	54	35
NK-5020068--	54 x 42	54	42
KJ-1022068--	42 x 35	42	35
NJ-1022068--	54 x 35	54	35
NK-1022068--	54 x 42	54	42
KJ-1222068--	42 x 35	42	35
NJ-1222068--	54 x 35	54	35
NK-1222068--	54 x 42	54	42
QN-2020068--	67 x 54	67	54
RQ-2020068--	76 x 67	76	67
RN-2020068E-	76 x 54	76	54

All sizes are in mm unless otherwise stated

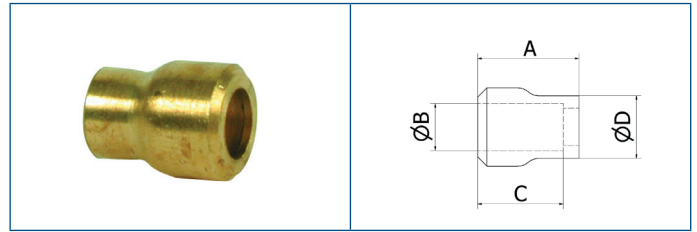

Internal Reducer - 68S (For Copper Tube Only)

Code	Fitting size	A	B	C	D
BA-5020068S-	8 x 6	13	6	11	8

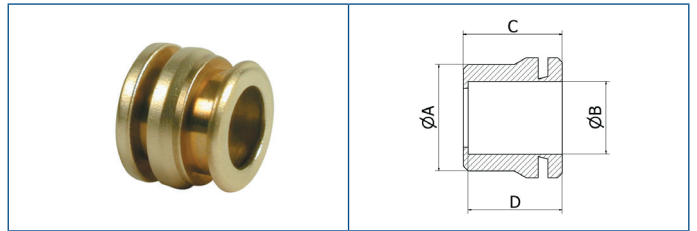

Male to Female Adaptor - S68SP

(For Copper Tube Only)

Code	Fitting size	A	B	C	D
CB-5020M68SP	10 x 8	10	8	14	13
DB-5020M68SP	12 x 8	12	8	15	14
DC-5020M68SP	12 x 10	12	10	15	14
EB-5020M68SP	15 x 8	15	8	14.5	13.5
EC-5020M68SP	15 x 10	15	10	14.5	13.5
ED-5020M68SP	15 x 12	15	12	17.5	16.5
FD-5020M68SP	18 x 12	18	12	18	17
FE-5020M68SP	18 x 15	18	15	18	17
GD-5020M68SP	22 x 12	22	12	17.5	16.5
GE-5020M68SP	22 x 15	22	15	17.5	16.5
GF-5020M68SP	22 x 18	22	18	17.5	16.5
HE-5020M68SP	28 x 15	28	15	21	20
HF-5020M68SP	28 x 18	28	18	21	20
HG-5020M68SP	28 x 22	28	22	21	20
JG-5020M68SP	35 x 22	35	22	24	23
JH-5020M68SP	35 x 28	35	28	24	23

35



Metric to Imperial Adaptor Ring - S68S

Code	Fitting size	A	B	C
K071020068S-	42mm x 1-1/2"	41	11	44
S405020068S-	108 x 4"	108	29	114

Range Code:

Brass
 DZR
 Red Brass

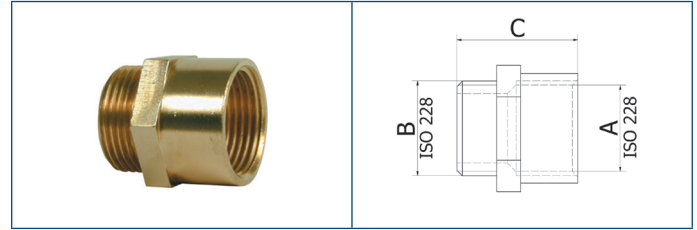

Male to Female Adaptor - 72

Code	Fitting size	A	B	C
03-1020072--	1/2"	1/2"	1/2	22
04-1020072--	3/4"	3/4"	3/4	34



Adaptor for Tap Extension - 74

Code	Fitting size	A	B	C	D	E
04-1020074--	3/4"	3/4"	3/4	10	11	23

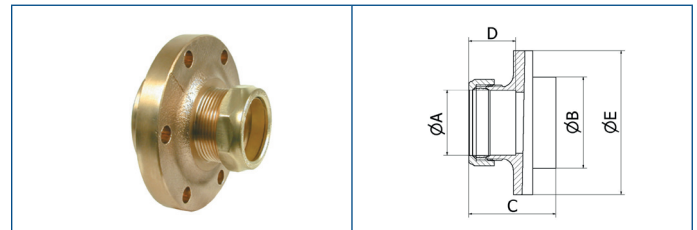

External Reducer - G68E

Code	Fitting size	A	B	C	D	E
RN-2020068E-	76 x 54	76	54	70	36	120

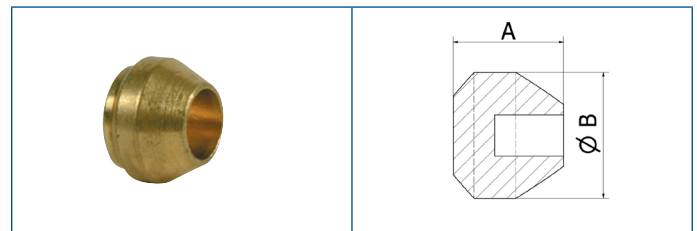

Blank Piece - S61

Code	Fitting size	A	B
D--5020061--	12	12	14
E--5020061--	15	15	18
G--5020061--	22	22	25

All sizes are in mm unless otherwise stated

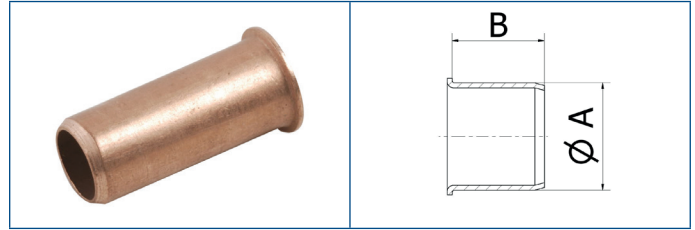

Soft Copper Liner - SC1

Code	Fitting size	A	B
C103031000SC	10 x 1.0	9.5	7.75
D103031000SC	12 x 1.0	11.5	9.75
E103031000SC	15 x 1.0	14.5	12.75
UT-3020000SC	16 x 1.0	15.5	13.75
F103031000SC	18 x 1.0	17.5	15.75
G103031000SC	22 x 1.0	21.5	19.75

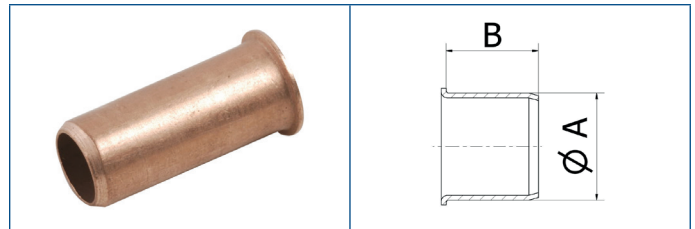

Internal Liner - PP (PE-X / PB)

Code	Fitting size	A	B
C183031000PP	10mm - Pe-X / PB	10	6.5
E183031000PP	15mm - PB	15	11.2
E183031000PP	15mm - PE-X	15	11.5
G183031000PP	22mm - PE-X/PB	22	17.5
H293031000PP	28mm - PE-X/PB	28	22.4

Range Code:

Brass
 DZR
 Red Brass

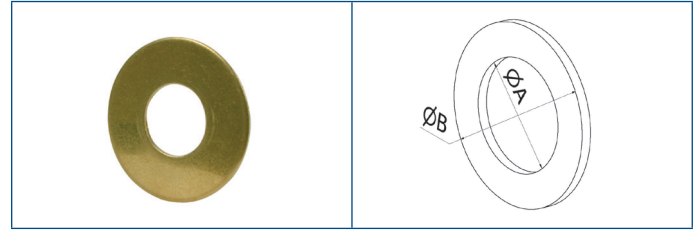

Brass Washer - 96

Code	Fitting size	A	B
03-1020096---	1/2"	22	50
04-1020096--	3/4"	27	56
05-1020096--	1"	34	61

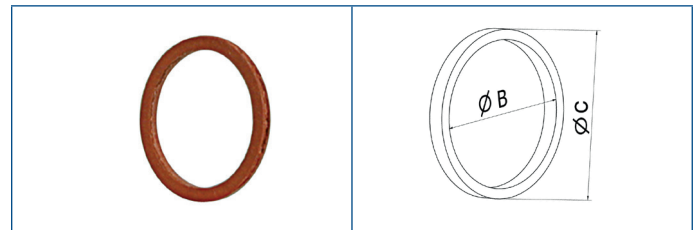

Tap Sealing Washer - 97

Code	Fitting size	A	B	C
03-9020097--	1/2"	1/2"	14.5	18.5
04-9020097--	3/4"	3/4"	19.5	24

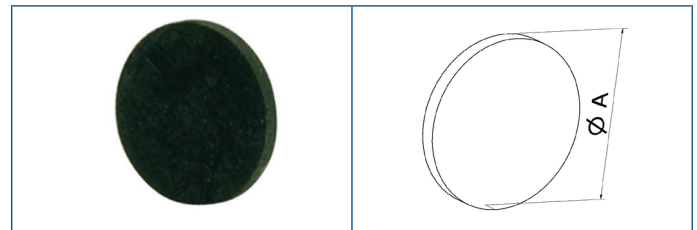

Blank Capnut Rubber Washer - 98

Code	Fitting size	A
E--9020098--	15	18.6
G--9020098--	22	26.2
H--9020098--	28	32.5

All sizes are in mm unless otherwise stated

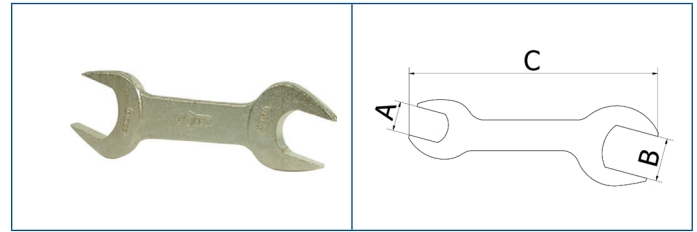

Capnut Spanner Zinc Plated - 85

Code	Fitting size	A	B	C
GE-9520085--	22 x 15	22	15	185

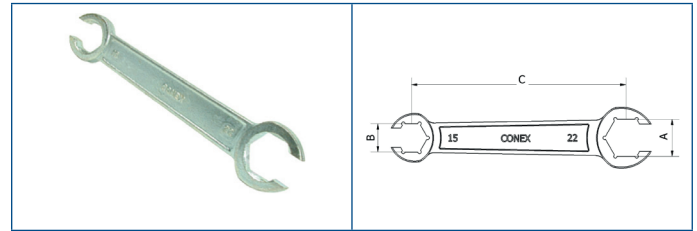

"C" Capnut Ring Spanner Zinc Plated - 85R

Code	Fitting size	A	B	C
GGE-9020085R-	22 x 15	22	15	190

Right to make amendments / Liability declaration

Please note that all illustrations, measurements and instructions in this document are a representation of Conex Compression fittings. These are not binding and we reserve the right to make amendments without notice. Please note technical advice is based on the current knowledge of the department at the time of creation and publication – 2017/11.

10.0 Guarantee

When professionally installed and used in accordance with our guidelines, Compression fittings supplied by Conex Universal are guaranteed against manufacturing defects for 25 years from the date of first purchase. Any alleged defects must be reported to Conex Universal Ltd. within one month of the first occurrence, clearly setting out the nature of the claim.

The guarantee is limited to the repair or replacement of defective fittings at the discretion of Conex Universal Ltd. and the company reserves the right to inspect and test the alleged defects. This guarantee provided by Conex Universal Ltd. does not affect your statutory rights.

The guarantee set out above is given by Conex Universal Ltd. and subject to the following conditions:

A. Any alleged defects must be reported to Conex Universal Ltd. within one month of the first occurrence of any such alleged defect, clearly setting out the nature of the claim and the circumstances surrounding it.

B. Conex Universal Ltd. shall be under no liability in respect of any defect in any product arising from:

- defective installation,
- fair wear and tear,
- wilful damage,
- negligence of any party other than Conex Universal Ltd.,
- abnormal working or environmental conditions,
- failure to follow the instructions of Conex Universal Ltd.,
- misuse (which includes any use of the product(s) concerned for a purpose or in a situation / environment or for an application other than that for which it was designed), or
- alteration or repair of any product without the prior approval of Conex Universal Ltd.

C. At the request of Conex Universal Ltd. the person claiming under this guarantee must deliver to Conex Universal Ltd. written evidence of the date of first purchase by an end user of the product(s) concerned.

**** The address for returns is:**

Customer Services
 Conex Universal Limited
 Global House
 95 Vantage Point
 The Pensnett Estate
 Kingswinford
 West Midlands
 DY6 7FT
 UNITED KINGDOM



Conex | Bänninger

Conex Bänninger
>B< Press

Conex Bänninger
>B< Press Gas

Conex Bänninger
>B< Press Solar

Conex Bänninger
>B< Press XL

Conex Bänninger
>B< Press Carbon

Conex Bänninger
>B< Press Inox

Conex Bänninger
>B< MaxiPro

Conex Bänninger
>B< ACR

K65[®]

Conex Bänninger
>B< Push

Conex Bänninger
>B< Flex

Conex Bänninger
>B< Oyster

Conex Bänninger
Cuprofit

Conex Bänninger
Triflow Solder Ring

Conex Bänninger
Delcop End Feed

Conex Bänninger
Delbraze

Conex Bänninger
Medical Gas

Conex Bänninger
Valves

Conex Bänninger
Conex Compression

Conex Bänninger
Series 3000

Conex | Bänninger
Series 4000

Conex | Bänninger
Series 5000

Conex Bänninger
Series 8000

Conex Bänninger
OEM



United Kingdom
Conex Universal Limited

Germany
IBP GmbH

Spain/France
IBP Atcosa SL

Italy
IBP Banninger Italia srl

Poland Sales, Marketing and Logistics
IBP Instalittings Sp z.o.o.

China
IBP China

Tel: +44 (0)121 557 2831 | Fax: +44 (0)121 557 0185 | Email: salesuk@ibpgroup.com | www.conexbanninger.com

The content of this publication is for general information only. It is the user's responsibility to determine suitability of any product for the purpose intended and reference should be made to our Technical Department if clarification is required. In the interests of technical development we reserve the right to change specification, design and materials without notice.

Conex Bänninger products are approved by numerous Standards Authorities and Certification Bodies. This is a representation of the full range from Conex Universal Ltd. IBP trademarks are registered in numerous countries.