

DELTECH ENGINEERING SDN BHD

Tel/ Whatsapp: 012-7118670

www.deltechhardware.com.my

怡通五金鋼鐵有限公司
DELTECH ENGINEERING SDN. BHD.
(Company No: 99119-X)
No. 23, Jalan Permasang 12,
Taman Desa Jaya, 81100
Johor Bahru, Johor,
Tel: 07-3558110, 3558217, 3558231
Fax: 07-3558110

Teikiro

WRENCH



TEKIRO Wrenches are manufactured exceeding JIS standards. All are forged from chrome vanadium steel, precision machined, heat treated to exacting standards. They fulfil the needs of the professional engineer.

- Drop forged to ensure uniform grain structure, giving increased strength and reliability.
- Heat treated in carefully controlled conditions to ensure optimum performance for every wrench.
- Chrome nickel silver plated for maximum corrosion protection.

TEKIRO advanced ring configuration increases the contact area between the wrench and fastener, minimizing stress and reducing the chance of fastener damage.

COMBINATION WRENCHES

TEKIRO combination wrenches feature Stress Relief Drive on the ring end. All open jaw ends feature a constant radius of curvature reducing stress concentrations and jaw flexing. Both of these features enhance fastener grip and prolong both tool and fastener life. All Tekiro combination wrenches exceed JIS Standards.

TEKIRO combination wrenches are supplied in 2 different size variants : metric and inch.

TEKIRO combination wrenches are clearly marked with the wrench size on the open jaw head for ease of identification.

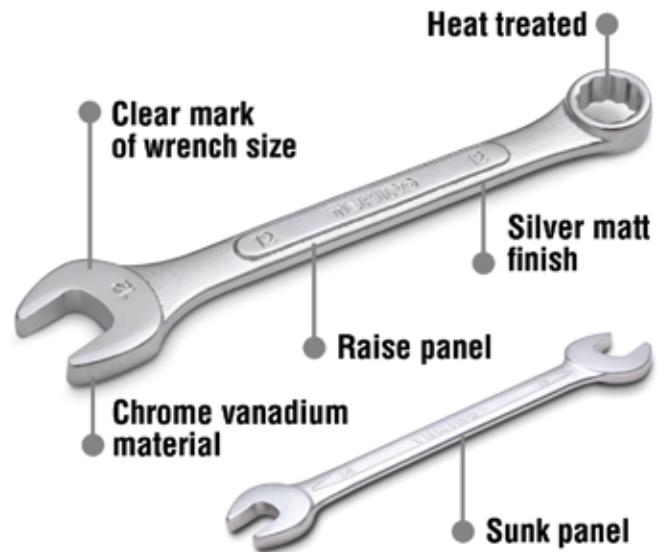

OPEN END WRENCHES

TEKIRO open jaw ends feature a constant radius of curvature - reducing stress concentrations and jaw flexing.



BOX END WRENCHES

TEKIRO ring wrench are offset at 45° for ease of access and feature stress relief drive.



SAFETY INSTRUCTION



DO NOT grind or alter the shape of the wrench



DO NOT strike the wrench unless it is designed for this purpose



Always ensure there is a positive fit onto the fastener



DO NOT extend length of wrench by locking together or extension bar



WRENCH

TORQUE

SOCKET

IMPACT SOCKET

PLIER

SCREWDRIVER

- Chrome vanadium steel
- Dropped forged and heat treated for extra strength
- Silver Matt finish
- Raised Panel type provides added strength

COMBINATION WRENCH

KUNCI RING PAS

METRIC

ITEM CODE	SIZE	1 (mm)	2 (mm)	3 (mm)	4 (mm)	5 (mm)	6 (mm)	7 (mm)	WEIGHT (gr)	QTY / BOX
WR-C00001	6 mm	93	10	6	3	4	13	6	23	12 / 480 pcs
WR-C00002	7 mm	98	11	7	3	4	16	7	26	12 / 480 pcs
WR-C00003	8 mm	102	14	8	6	6	19	8	30	12 / 240 pcs
WR-C00004	9 mm	116	14	9	4	6	20	9	40	12 / 240 pcs
WR-C00005	10 mm	122	17	10	6	8	23	10	47	12 / 240 pcs
WR-C00006	11 mm	131	17	11	6	7	25	11	54	12 / 240 pcs
WR-C00007	12 mm	142	18	10	6	7	25	12	59	12 / 240 pcs
WR-C00008	13 mm	148	19	13	5	7	26	13	77	12 / 144 pcs
WR-C00009	14 mm	168	22	14	7	8	30	14	101	12 / 144 pcs
WR-C00010	15 mm	189	24	15	7	9	32	15	119	12 / 144 pcs
WR-C00011	16 mm	189	25	13	7	10	35	16	125	12 / 144 pcs
WR-C00012	17 mm	207	26	14	7	10	36	17	157	12 / 72 pcs
WR-C00013	18 mm	207	27	18	8	10	37	18	155	12 / 72 pcs
WR-C00014	19 mm	230	29	19	8	10	39	19	186	12 / 72 pcs
WR-C00015	20 mm	262	31	20	7	10	43	20	251	12 / 72 pcs
WR-C00016	21 mm	255	31	21	10	12	43	21	223	6 / 72 pcs
WR-C00017	22 mm	279	34	22	9	11	45	22	320	6 / 36 pcs
WR-C00018	23 mm	280	34	17	10	12	44	23	325	6 / 36 pcs
WR-C00019	24 mm	304	35	24	10	12	49	24	432	6 / 36 pcs
WR-C00020	25 mm	329	38	25	10	12	51	25	480	6 / 24 pcs
WR-C00021	26 mm	325	38	26	11	12	51	26	530	6 / 24 pcs
WR-C00022	27 mm	346	42	27	11	13	57	27	580	6 / 24 pcs
WR-C00023	28 mm	358	42	28	11	13	57	28	584	6 / 24 pcs
WR-C00024	29 mm	380	43	28	11	13	57	29	642	6 / 24 pcs
WR-C00025	30 mm	380	43	30	11	13	60	30	680	6 / 24 pcs
WR-C00026	32 mm	429	48	27	14	18	65	32	884	6 / 24 pcs
WR-C00027	33 mm	435	50	33	15	18	66	33	1,130	5 / 20 pcs
WR-C00028	34 mm	430	50	26	14	18	66	34	1,170	5 / 20 pcs
WR-C00029	35 mm	434	51	35	16	20	67	35	1,220	5 / 20 pcs
WR-C00030	36 mm	489	54	36	16	21	74	36	1,480	5 / 20 pcs
WR-C00031	38 mm	518	55	38	16	21	83	38	1,760	5 / 20 pcs
WR-C00032	41 mm	545	64	41	17	23	92	41	2,180	5 / 10 pcs
WR-C00033	42 mm	543	65	33	16	22	91	42	2,320	5 / 10 pcs
WR-C00034	46 mm	545	65	46	17	22	90	46	2,041	5 / 10 pcs
WR-C00035	50 mm	610	72	50	20	24	95	50	2,680	5 / 10 pcs
WR-C00036	55 mm	630	90	55	20	30	12	55	3,040	1 / 5 pcs
WR-C00037	60 mm	630	90	60	19	29	13	60	3,490	1 / 5 pcs

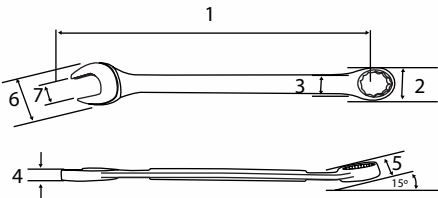

INCH

ITEM CODE	SIZE	1 (mm)	2 (mm)	3 (mm)	4 (mm)	5 (mm)	6 (mm)	WEIGHT (gr)	QTY / BOX
WR-C00038	5 / 16"	102	19	13	5	6	8	31	12 / 240 pcs
WR-C00039	3 / 8"	116	21	15	5	6	10	40	12 / 240 pcs
WR-C00040	7 / 16"	131	25	17	6	7	25	54	12 / 240 pcs
WR-C00041	1 / 2"	148	28	20	6	8	13	84	12 / 144 pcs
WR-C00042	9 / 16"	168	30	22	7	8	15	98	12 / 144 pcs
WR-C00043	5 / 8"	189	32	24	7	9	16	118	12 / 144 pcs
WR-C00044	11 / 16"	207	37	27	8	10	18	169	12 / 72 pcs
WR-C00045	3 / 4"	230	40	29	8	11	19	200	12 / 72 pcs
WR-C00046	13 / 16"	260	43	32	9	12	43	257	6 / 36 pcs
WR-C00047	7 / 8"	280	44	34	10	12	23	292	6 / 36 pcs
WR-C00048	15 / 16"	310	49	36	11	12	25	354	6 / 36 pcs
WR-C00049	1"	333	51	38	11	13	26	462	6 / 24 pcs
WR-C00050	1-1 / 16"	361	57	42	11	13	27	610	6 / 24 pcs
WR-C00051	1-1 / 8"	382	60	44	12	14	60	663	6 / 24 pcs
WR-C00052	1-1 / 4"	412	64	48	12	15	64	868	6 / 24 pcs

BOX END WRENCH

KUNCI RING

- Chrome vanadium steel
- Dropped forged and heat treated for extra strength
- Silver Matt finish
- Raised Panel type provides added strength

ITEM CODE	SIZE	1 (mm)	2 (mm)	3 (mm)	4 (mm)	5 (mm)	6 (mm)	7 (mm)	WEIGHT (gr)	QTY / BOX INNER/MASTER
WR-BE0053	6 X 7 mm	163	11	12	6	6	6	7	50	12 / 360 pcs
WR-BE0054	8 X 9 mm	174	14	15	6	6	8	9	63	12 / 360 pcs
WR-BE0055	8 X 10 mm	174	14	15	6	7	8	10	71	12 / 360 pcs
WR-BE0056	10 X 11 mm	186	16	18	6	7	10	11	81	12 / 360 pcs
WR-BE0057	10 X 12 mm	187	16	19	7	7	10	12	80	12 / 360 pcs
WR-BE0058	12 X 13 mm	216	19	22	7	8	12	13	132	12 / 192 pcs
WR-BE0059	12 X 14 mm	211	19	22	7	8	12	14	168	12 / 192 pcs
WR-BE0060	14 X 15 mm	246	24	27	9	9	14	15	197	12 / 120 pcs
WR-BE0061	14 X 17 mm	245	24	27	11	11	14	17	197	12 / 120 pcs
WR-BE0062	16 X 17 mm	244	24	27	10	10	16	17	193	12 / 120 pcs
WR-BE0063	17 X 19 mm	289	29	31	11	11	17	19	253	6 / 96 pcs
WR-BE0064	18 X 19 mm	289	29	33	11	11	18	19	272	6 / 96 pcs
WR-BE0065	19 X 21 mm	295	29	33	11	11	19	21	290	6 / 60 pcs
WR-BE0066	20 X 22 mm	296	31	34	11	11	20	22	289	6 / 60 pcs
WR-BE0067	21 X 23 mm	312	33	36	11	11	21	23	369	6 / 60 pcs
WR-BE0068	22 X 24 mm	319	33	36	11	12	22	24	373	6 / 60 pcs
WR-BE0069	24 X 27 mm	368	37	38	13	12	24	27	575	6 / 36 pcs
WR-BE0070	25 X 28 mm	375	39	46	14	15	25	28	744	6 / 36 pcs
WR-BE0071	30 X 32 mm	405	47	48	15	15	30	32	833	6 / 36 pcs

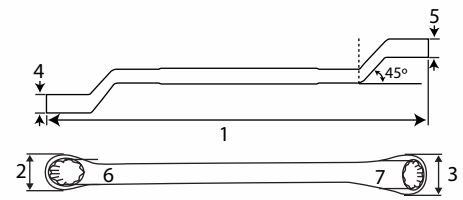

OPEN END WRENCH

KUNCI PAS

- Chrome vanadium steel
- Dropped forged and heat treated for extra strength
- Silver Matt finish
- Raised Panel type provides added strength

ITEM CODE	SIZE	1 (mm)	2 (mm)	3 (mm)	4 (mm)	5 (mm)	6 (mm)	7 (mm)	WEIGHT (gr)	QTY / BOX INNER/MASTER
WR-OE0072	6 X 7 mm	96	15	16	5	5	6	7	28	12 / 480 pcs
WR-OE1649	6 X 8 mm	96	15	15	4	4	6	8	33	12 / 480 pcs
WR-OE0073	8 X 9 mm	110	18	19	5	5	8	9	38	12 / 480 pcs
WR-OE0074	8 X 10 mm	110	18	20	5	4	8	10	35	12 / 480 pcs
WR-OE0075	10 X 11 mm	126	22	26	6	6	10	11	56	12 / 480 pcs
WR-OE0076	10 X 12 mm	126	21	25	4	4	10	12	58	12 / 480 pcs
WR-OE0077	12 X 13 mm	140	27	29	6	6	12	13	78	12 / 192 pcs
WR-OE0078	12 X 14 mm	141	27	29	6	6	12	14	79	12 / 192 pcs
WR-OE0079	14 X 15 mm	157	30	34	7	7	14	15	102	12 / 192 pcs
WR-OE0080	14 X 17 mm	160	30	34	7	7	14	17	103	12 / 192 pcs
WR-OE0081	16 X 17 mm	172	33	36	7	7	16	17	130	12 / 192 pcs
WR-OE0082	17 X 19 mm	188	37	39	7	7	17	19	180	6 / 96 pcs
WR-OE0083	18 X 19 mm	188	37	39	7	7	18	19	176	12 / 96 pcs
WR-OE0084	19 X 21 mm	212	41	46	8	8	19	21	276	6 / 96 pcs
WR-OE0085	20 X 22 mm	210	46	41	9	9	20	22	273	12 / 72 pcs
WR-OE0086	21 X 23 mm	210	46	46	10	10	21	23	260	6 / 96 pcs
WR-OE0087	22 X 24 mm	211	41	46	10	10	22	24	243	6 / 72 pcs
WR-OE0088	24 X 27 mm	254	50	50	10	10	24	27	356	6 / 72 pcs
WR-OE0089	25 X 28 mm	270	54	64	10	10	25	28	497	6 / 36 pcs
WR-OE0090	30 X 32 mm	293	58	64	12	12	30	32	688	6 / 36 pcs

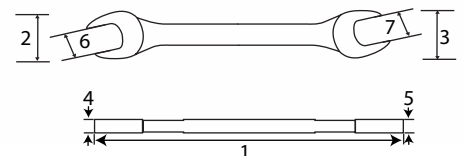

WRENCH

TORQUE

SOCKET

IMPACT SOCKET

PLIER

SCREWDRIVER

- Chrome vanadium steel
- Dropped forged and heat treated for extra strength
- Silver Matt finish
- German Type (DIN 899)
- Sunk panel for easy access to tight spaces

COMBINATION WRENCH - SUNK PANEL

KUNCI RING PAS - SUNK PANEL

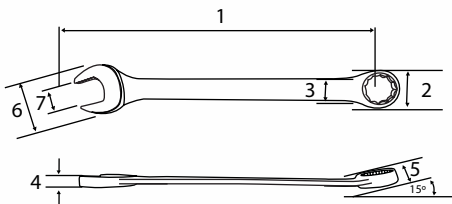

ITEM CODE	SIZE	1 (mm)	2 (mm)	3 (mm)	4 (mm)	5 (mm)	6 (mm)	7 (mm)	WEIGHT (gr)	QTY / BOX INNER/MASTER
WR-C00091	6 mm	105	10	6	3	4	14	6	21	12 / 480 pcs
WR-C00092	7 mm	116	12	7	4	5	16	7	25	12 / 480 pcs
WR-C00093	8 mm	125	13	8	3	5	18	8	25	12 / 480 pcs
WR-C00094	9 mm	135	13	9	3	5	20	9	32	12 / 240 pcs
WR-C00095	10 mm	136	14	10	3	5	21	10	31	12 / 240 pcs
WR-C00096	11 mm	155	17	11	4	7	25	11	48	12 / 240 pcs
WR-C00097	12 mm	165	19	12	5	6	26	12	62	12 / 240 pcs
WR-C00098	13 mm	175	19	13	5	7	28	13	75	12 / 144 pcs
WR-C00099	14 mm	185	22	14	5	7	30	14	83	12 / 144 pcs
WR-C00100	15 mm	196	23	15	6	8	33	15	106	12 / 144 pcs
WR-C00101	16 mm	206	24	16	6	8	33	16	116	12 / 144 pcs
WR-C00102	17 mm	216	25	17	7	9	35	17	133	12 / 144 pcs
WR-C00103	18 mm	227	27	18	7	8	38	18	160	12 / 144 pcs
WR-C00104	19 mm	234	28	19	7	10	40	19	170	12 / 120 pcs
WR-C00105	20 mm	245	29	20	7	10	43	20	196	12 / 72 pcs
WR-C00106	21 mm	256	32	21	8	10	45	21	219	6 / 72 pcs
WR-C00107	22 mm	267	33	22	8	12	46	22	230	6 / 72 pcs
WR-C00108	23 mm	273	33	23	8	12	46	23	260	6 / 72 pcs
WR-C00109	24 mm	286	35	24	8	12	48	24	298	6 / 72 pcs
WR-C00110	25 mm	295	37	25	8	11	51	25	315	6 / 36 pcs
WR-C00111	26 mm	300	38	26	9	10	52	26	348	6 / 36 pcs
WR-C00112	27 mm	310	39	27	8	11	55	27	356	6 / 48 pcs
WR-C00113	28 mm	323	41	28	10	12	56	29	429	6 / 36 pcs
WR-C00114	29 mm	331	42	29	10	13	59	29	480	6 / 36 pcs
WR-C00115	30 mm	340	44	30	10	13	61	30	499	6 / 36 pcs
WR-C00116	32 mm	360	46	32	11	13	64	32	587	6 / 36 pcs

- Chrome vanadium steel
- Dropped forged
- Silver Matt finish
- German Type (DIN 899)
- 45 Degree

BOX END WRENCH 45 DEGREE - SUNK PANEL

KUNCI RING - SUNK PANEL

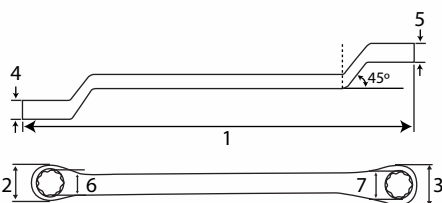

ITEM CODE	SIZE	1 (mm)	2 (mm)	3 (mm)	4 (mm)	5 (mm)	6 (mm)	7 (mm)	WEIGHT (gr)	QTY / BOX INNER/MASTER
WR-BE0117	6 X 7 mm	170	11	13	13	5	6	7	48	12 / 360 pcs
WR-BE0118	8 X 9 mm	174	14	15	15	7	8	9	60	12 / 300 pcs
WR-BE0119	8 X 10 mm	189	14	16	16	6	8	10	72	12 / 300 pcs
WR-BE0120	10 X 11 mm	200	16	18	18	7	10	11	98	12 / 240 pcs
WR-BE0121	10 X 12 mm	187	16	19	19	8	10	12	93	12 / 240 pcs
WR-BE0122	12 X 13 mm	211	19	21	21	8	12	13	107	12 / 192 pcs
WR-BE0123	12 X 14 mm	225	20	21	21	8	12	14	134	12 / 144 pcs
WR-BE0124	14 X 15 mm	237	22	23	23	8	14	15	151	12 / 120 pcs
WR-BE0125	14 X 17 mm	241	22	25	25	9	14	17	159	12 / 120 pcs
WR-BE0126	16 X 17 mm	250	25	26	26	9	16	17	178	12 / 120 pcs
WR-BE0127	17 X 19 mm	257	25	27	27	10	17	19	215	12 / 96 pcs
WR-BE0128	18 X 19 mm	259	22	28	28	11	18	20	219	6 / 96 pcs
WR-BE0129	19 X 21 mm	277	28	30	30	11	19	21	242	12 / 96 pcs
WR-BE0130	20 X 22 mm	282	29	32	32	11	20	22	260	6 / 96 pcs
WR-BE0131	21 X 23 mm	301	31	33	33	11	21	23	326	6 / 72 pcs
WR-BE0132	22 X 24 mm	333	32	34	34	11	22	24	379	6 / 60 pcs
WR-BE0133	24 X 27 mm	376	34	39	39	12	24	27	474	6 / 36 pcs
WR-BE0134	25 X 28 mm	377	35	40	40	15	25	28	524	6 / 30 pcs
WR-BE0135	30 X 32 mm	389	42	48	48	15	30	32	670	6 / 30 pcs

BOX END WRENCH 75 DEGREE - SUNK PANEL

KUNCI RING 75° - SUNK PANEL

- Chrome vanadium steel
- Dropped forged
- Silver Matt finish
- German Type (DIN 899)

ITEM CODE	SIZE	1 (mm)	2 (mm)	3 (mm)	4 (mm)	5 (mm)	6 (mm)	7 (mm)	WEIGHT (gr)	QTY / BOX INNER/MASTER
WR-BE0136	6 X 7 mm	174	12	13	5	5	6	7	59	12 / 240 pcs
WR-BE0137	8 X 9 mm	178	13	15	6	6	8	9	54	12 / 240 pcs
WR-BE0138	8 X 10 mm	191	13	15	6	6	8	10	77	12 / 240 pcs
WR-BE0139	10 X 11 mm	207	16	17	6	7	10	11	108	12 / 144 pcs
WR-BE0140	10 X 12 mm	208	16	18	7	7	10	12	111	12 / 144 pcs
WR-BE0141	12 X 13 mm	210	19	21	6	7	12	13	103	12 / 96 pcs
WR-BE0142	12 X 14 mm	226	19	21	7	7	12	14	142	12 / 96 pcs
WR-BE0143	14 X 15 mm	247	21	23	8	9	14	15	175	12 / 96 pcs
WR-BE0144	14 X 17 mm	251	21	26	8	9	14	17	214	12 / 72 pcs
WR-BE0145	16 X 17 mm	245	25	26	9	10	16	17	176	12 / 72 pcs
WR-BE0146	17 X 19 mm	257	25	27	10	10	17	19	215	6 / 48 pcs
WR-BE0147	18 X 19 mm	303	28	29	10	10	18	19	263	6 / 48 pcs
WR-BE0148	19 X 21 mm	275	29	33	12	12	19	21	266	6 / 48 pcs
WR-BE0149	20 X 22 mm	326	31	33	10	11	20	22	355	6 / 48 pcs
WR-BE0150	21 X 23 mm	340	31	35	12	12	21	23	401	6 / 36 pcs
WR-BE0151	22 X 24 mm	325	33	35	11	12	22	24	374	6 / 36 pcs
WR-BE0152	24 X 27 mm	365	36	39	12	13	24	27	462	6 / 36 pcs
WR-BE0153	25 X 28 mm	368	36	40	13	15	25	28	532	6 / 36 pcs
WR-BE0154	30 X 32 mm	380	40	46	15	16	30	32	652	6 / 24 pcs

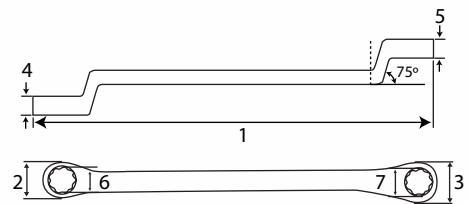

OPEN END WRENCH - SUNK PANEL

KUNCI PAS - SUNK PANEL

- Chrome vanadium steel
- Dropped forged
- Chrome Nickel Silver Matt finish
- German Type (DIN 899)
- Ends are slanted 15 degree for quick access

ITEM CODE	SIZE	1 (mm)	2 (mm)	3 (mm)	4 (mm)	5 (mm)	6 (mm)	7 (mm)	WEIGHT (gr)	QTY / BOX INNER/MASTER
WR-OE0155	6 X 7 mm	122	16	19	4	4	6	7	29	12 / 360 pcs
WR-OE0156	8 X 9 mm	110	18	19	4	4	8	9	41	12 / 360 pcs
WR-OE0157	8 X 10 mm	140	20	23	4	4	8	10	41	12 / 360 pcs
WR-OE0158	10 X 11 mm	155	26	28	5	5	10	11	66	12 / 360 pcs
WR-OE0159	10 X 12 mm	157	25	28	5	5	10	12	68	12 / 360 pcs
WR-OE0160	12 X 13 mm	163	29	31	6	6	12	13	88	12 / 240 pcs
WR-OE0161	12 X 14 mm	181	31	33	6	6	12	14	102	12 / 144 pcs
WR-OE0162	14 X 15 mm	190	33	34	6	6	14	15	111	12 / 144 pcs
WR-OE0163	14 X 17 mm	155	33	34	6	6	14	17	168	12 / 144 pcs
WR-OE0164	16 X 17 mm	204	37	38	7	7	16	17	133	12 / 144 pcs
WR-OE0165	17 X 19 mm	188	37	39	7	7	17	19	224	12 / 96 pcs
WR-OE0166	18 X 19 mm	188	37	39	7	7	18	19	173	12 / 96 pcs
WR-OE0167	19 X 21 mm	233	43	47	7	7	19	21	221	12 / 96 pcs
WR-OE0168	20 X 22 mm	234	44	47	8	8	20	22	221	12 / 96 pcs
WR-OE0169	21 X 23 mm	210	41	46	8	8	21	23	248	12 / 72 pcs
WR-OE0170	22 X 24 mm	247	46	50	8	8	22	24	244	12 / 72 pcs
WR-OE0171	24 X 27 mm	254	48	50	9	9	24	27	473	6 / 60 pcs
WR-OE0172	25 X 28 mm	276	55	61	10	10	25	28	389	6 / 60 pcs
WR-OE0173	30 X 32 mm	293	58	64	10	10	30	32	668	6 / 36 pcs
SA-OE1467	36 X 41 mm	307	90	74	13	13	41	36	1,092	5 / 20 pcs

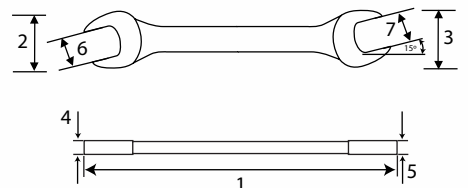

WRENCH

TORQUE

SOCKET

IMPACT SOCKET

PLIER

SCREWDRIVER

STUBBY GEAR WRENCHES

Ratcheting at 5 degree arc made possible with 72 Gear teeth metal construction.

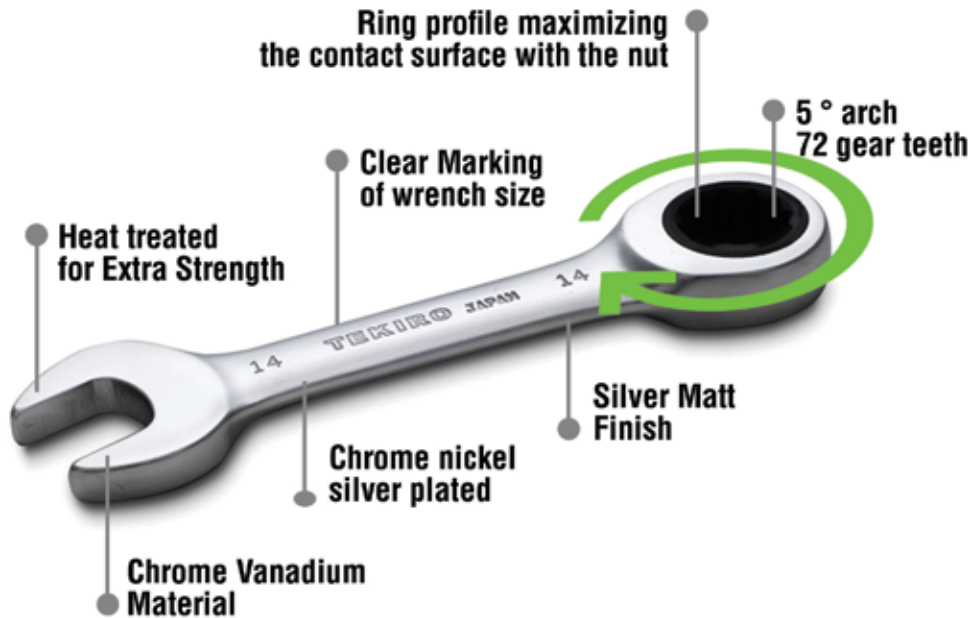

FLEXIBLE GEAR WRENCHES

Ratcheting at 5 degree arc made possible with 72 Gear teeth metal construction and Flexible Head tilts up to 90 degrees, enables greater access where standard wrench could not reach.

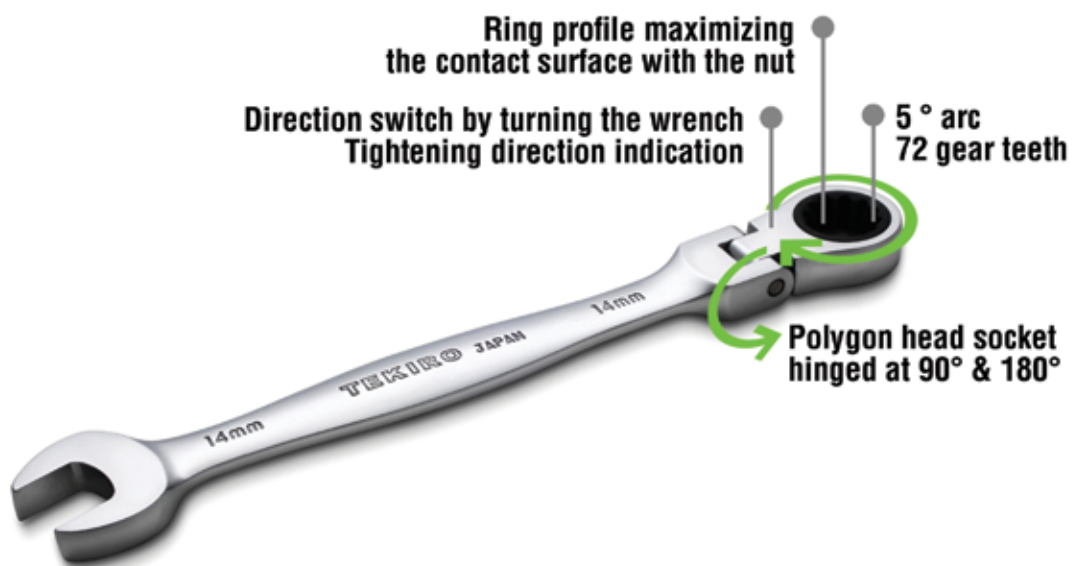



STUBBY GEAR WRENCH

KUNCI RING PAS RATCHET PENDEK

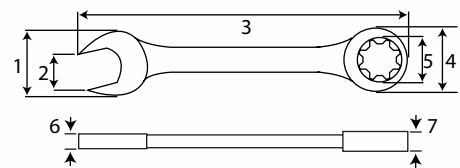

ITEM CODE	SIZE	1 (mm)	2 (mm)	3 (mm)	4 (mm)	5 (mm)	6 (mm)	7 (mm)	WEIGHT (gr)	QTY / BOX INNER/MASTER
WR-SG0174	8 mm	23	11	104	21	8	4	7	60	12 / 288 pcs
WR-SG0175	10 mm	20	10	97	20	10	5	8	51	12 / 288 pcs
WR-SG0176	11 mm	23	11	104	22	11	5	8	58	12 / 216 pcs
WR-SG0177	12 mm	24	12	104	22	12	6	9	66	12 / 216 pcs
WR-SG0178	13 mm	27	13	108	25	13	6	9	76	12 / 144 pcs
WR-SG0179	14 mm	29	14	117	28	10	6	9	93	12 / 144 pcs
WR-SG0180	17 mm	35	17	127	32	17	7	9	136	12 / 96 pcs
WR-SG0181	19 mm	29	19	139	36	19	7	12	177	12 / 72 pcs

- Chrome vanadium steel
- Drop Forged for extra strength
- Flat Panel type with Silver Matt Finish
- Ratcheting at 5 degree arc made possible with 72 Gear teeth metal construction.



SINGLE GEAR WRENCH

KUNCI RING PAS RATCHET PANJANG

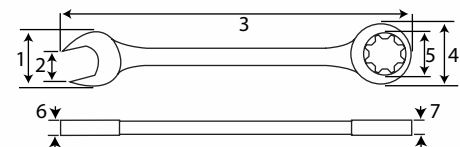

ITEM CODE	SIZE	1 (mm)	2 (mm)	3 (mm)	4 (mm)	5 (mm)	6 (mm)	7 (mm)	WEIGHT (gr)	QTY / BOX INNER/MASTER
WR-SG0182	8 mm	16	8	139	16	8	5	6	48	12 / 216 pcs
WR-SG0183	10 mm	20	10	159	20	10	6	8	66	12 / 216 pcs
WR-SG0184	11 mm	22	11	165	20	11	6	7	99	12 / 216 pcs
WR-SG0185	12 mm	24	12	171	22	12	6	7	86	12 / 144 pcs
WR-SG0186	13 mm	26	13	177	24	13	6	7	100	12 / 144 pcs
WR-SG0187	14 mm	28	14	190	253	14	7	7	154	12 / 144 pcs
WR-SG0188	17 mm	35	17	225	32	17	7	11	185	12 / 72 pcs
WR-SG0189	19 mm	39	19	247	32	192	8	12	318	12 / 72 pcs

- Chrome vanadium steel
- Drop forged for extra strength
- Flat Panel type with Silver Matt Finish
- Ratcheting at 5 Degree arc made possible with 72 Gear teeth metal construction.

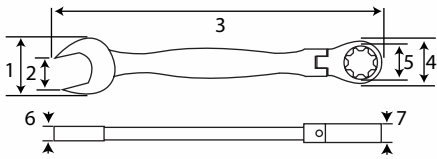

FLEXIBLE GEAR WRENCH

KUNCI RING PAS RATCHET FLEXIBLE

- Chrome vanadium steel
- With heat treatment for extra durability and strength
- Flat Panel type with Silver Matt Finish
- Ratcheting at 5 degree arc made possible with 72 Gear teeth metal construction
- Flex Head tilts up to 90 degrees, enables greater access where standard wrench could not reach

ITEM CODE	SIZE	1 (mm)	2 (mm)	3 (mm)	4 (mm)	5 (mm)	6 (mm)	7 (mm)	WEIGHT (gr)	QTY / BOX INNER/MASTER
WR-FG0190	8 mm	16	8	140	15	8	4	7	59	12 / 216 pcs
WR-FG0191	10 mm	20	10	158	17	10	6	8	88	12 / 216 pcs
WR-FG0192	11 mm	22	11	165	20	11	6	8	97	12 / 216 pcs
WR-FG0193	12 mm	24	12	171	22	12	6	9	154	12 / 144 pcs
WR-FG0194	13 mm	26	13	176	23	13	6	9	179	12 / 144 pcs
WR-FG0195	14 mm	29	15	192	25	14	7	9	204	12 / 144 pcs
WR-FG0196	17 mm	35	17	223	28	17	8	11	239	12 / 72 pcs
WR-FG0197	19 mm	40	19	245	31	19	9	12	315	12 / 72 pcs

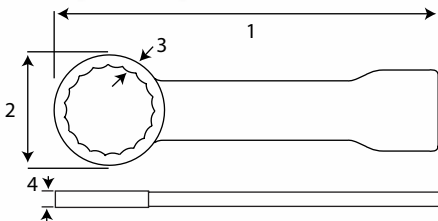

BOX IMPACT WRENCH

KUNCI RING IMPACT

- Material is Chrome Molybdenum
- Flat Striking face allow hammer blow
- DIN 899

ITEM CODE	SIZE	1 (mm)	2 (mm)	3 (mm)	4 (mm)	WEIGHT (gr)	QTY / BOX INNER/MASTER
WR-SL0198	27 mm	180	46	16	16	297	10 / 60 pcs
WR-SL0199	30 mm	190	52	17	17	398	10 / 60 pcs
WR-SL0200	32 mm	190	54	17	17	456	10 / 40 pcs
WR-SL0201	36 mm	205	59	19	20	508	10 / 30 pcs
WR-SL0202	41 mm	230	65	20	21	820	10 / 30 pcs
WR-SL0203	46 mm	240	74	22	23	1,051	5 / 20 pcs
WR-SL0204	50 mm	253	79	24	25	1,130	5 / 20 pcs
WR-SL0205	55 mm	266	85	25	25	1,260	5 / 10 pcs
WR-SL0206	60 mm	280	92	26	25	1,376	5 / 10 pcs



STAR WRENCH
KUNCI RING BINTANG

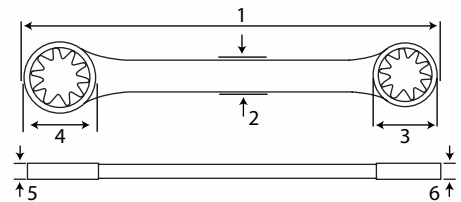

ITEM CODE	SIZE	1 (mm)	2 (mm)	3 (mm)	4 (mm)	5 (mm)	6 (mm)	WEIGHT (gr)	QTY / BOX INNER/MASTER
WR-ST0207	E6 X E8	113	6	6	8	5	6	19	1 / 300 pcs
WR-ST0208	E7 X E11	126	7	7	11	6	7	32	1 / 400 pcs
WR-ST0209	E10 X E12	140	9	10	12	7	8	42	1 / 300 pcs
WR-ST0210	E14 X E18	181	12	14	18	8	10	86	1 / 200 pcs
WR-ST0211	E16 X E22	201	13	16	22	10	11	131	1 / 150 pcs
WR-ST0212	E20 X E24	225	14	20	24	11	13	175	1 / 50 pcs

- Material is Chrome vanadium steel
- Dropped Forged
- German Type (DIN 899)
- Polished Finish
- Specially designed for E-Torx fastener



CONSTRUCTION WRENCH
KUNCI KONSTRUKSI

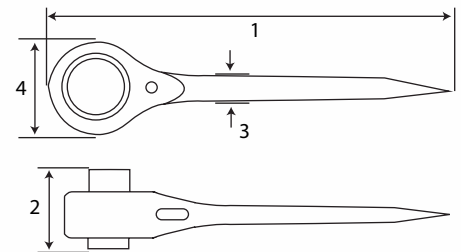

ITEM CODE	SIZE	1 (mm)	2 (mm)	3 (mm)	4 (mm)	WEIGHT (gr)	QTY / BOX INNER/MASTER
WR-CS0217	12 X 14 mm	241	37	11	27	192	2 / 60 pcs
WR-CS0218	14 X 17 mm	280	44	14	34	277	2 / 60 pcs
WR-CS0219	17 X 19 mm	315	49	17	43	468	2 / 50 pcs
WR-CS0220	19 X 21 mm	317	50	17	51	449	2 / 50 pcs
WR-CS0221	21 X 23 mm	360	55	22	60	792	2 / 30 pcs
WR-CS0222	22 X 24 mm	317	54	22	66	799	2 / 30 pcs
WR-CS0223	24 X 27 mm	360	56	23	51	867	2 / 30 pcs
WR-CS0224	27 X 30 mm	450	59	24	80	970	2 / 20 pcs
WR-CS0225	30 X 32 mm	450	63	25	89	1,011	2 / 20 pcs

- Chrome Molybdenum
- Torque and Hardness Exceeds DIN 899 Specification
- 32 teeth Ratchet
- Tip end can be used to twist Wire

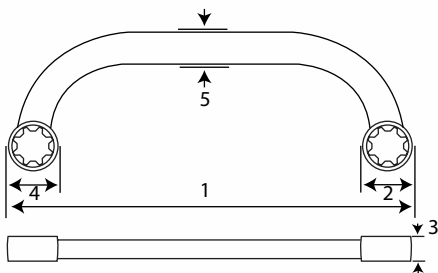

- Chrome vanadium steel
- Dropped forged
- Curved design for maximum access in confined areas
- Polished finish

OBSTRUCTION WRENCH

KUNCI RING BULAN

ITEM CODE	SIZE	1 (mm)	2 (mm)	3 (mm)	4 (mm)	5 (mm)	WEIGHT (gr)	QTY / BOX INNER/MASTER
WR-OB0226	10 X 12 mm	142	18	7	16	10	70	1 / 200 pcs
WR-OB0227	11 X 13 mm	164	18	8	21	11	118	1 / 200 pcs
WR-OB0228	14 X 17 mm	190	21	8	25	12	148	1 / 100 pcs
WR-OB0229	16 X 18 mm	219	24	10	28	13	218	1 / 60 pcs
WR-OB0230	19 X 22 mm	256	28	10	32	15	304	1 / 60 pcs

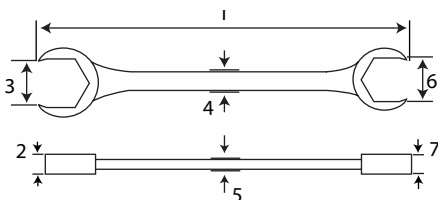

- Chrome vanadium steel
- Dropped forged
- Raised Panel type
- Polished Finish
- The flare nut wrench can be used to remove or replace nuts on fuel or brake lines
- Suits both auto and repair shops

FLARE NUT WRENCH

KUNCI NEPEL

ITEM CODE	SIZE	1 (mm)	2 (mm)	3 (mm)	4 (mm)	5 (mm)	6 (mm)	7 (mm)	WEIGHT (gr)	QTY / BOX INNER/MASTER
WR-FN0213	8 X 10 mm	152	5	8	10	4	10	7	47	24 / 360 pcs
WR-FN0214	10 X 12 mm	155	7	10	10	5	12	9	62	24 / 360 pcs
WR-FN0215	12 X 14 mm	174	9	12	12	6	14	12	97	24 / 240 pcs
WR-FN0216	14 X 17 mm	180	12	13	13	11	17	15	118	24 / 144 pcs

T-TYPE WRENCHES

TEKIRO T-Type Wrenches are manufactured from high strength and durable Chrome Vanadium alloy. It is designed to ease gripping, handling & increase torque performance. Rounded tip finish for better gripping and holding screws. Special surface treatment to prevent oxidation and corrosion. All Tekiro T-Type wrenches exceed JIS standards.

TEKIRO combination wrenches are supplied in 6 different variants : **T-Type Wrench Standard**, **T-Type Wrench Rubber Handle**, **T-Type Wrench Rotary**, **T-Type Wrench Adaptor**, **T-Type Wrench Screwdriver**, **T-Type Wrench Extra Long**.

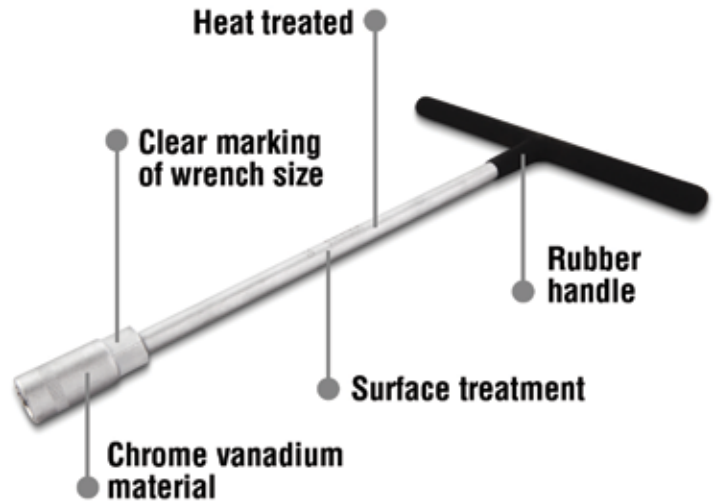

T-TYPE WRENCH ROTARY

TEKIRO T-Type Wrench rotary feature Free rotating grip for better control and speed.



T-TYPE WRENCH EXTRA LONG

TEKIRO T-Type wrench extra long enables greater access where standard T-Type wrench could not reach.



T-TYPE WRENCH ADAPTOR

TEKIRO T-Type Wrench adaptor features free rotating grip for better control, speed and can be used on a variety of sockets.



T-TYPE WRENCH SCREWDRIVER

TEKIRO T-Type wrench screwdriver enables greater access where standard screwdriver could not reach



- Chrome vanadium steel on socket head
- Heat treated for extra durability and strength

T-TYPE BOX WRENCH

T-TYPE SOCKET

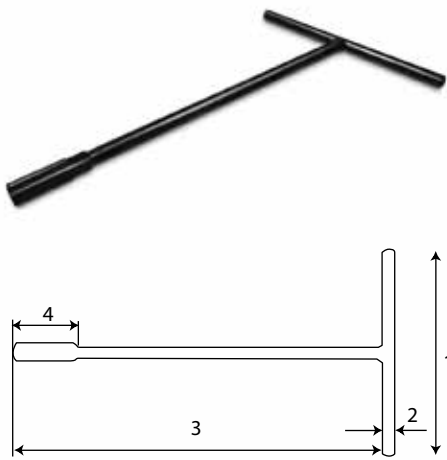

ITEM CODE	SIZE	1 (mm)	2 (mm)	3 (mm)	4 (mm)	5 (mm)	6 (mm)	7 (mm)	WEIGHT (gr)	QTY / BOX INNER/MASTER
WR-TT0231	7 mm	200	10	300	49	11 - 13	8	11	310	1 / 50 pcs
WR-TT0232	8 mm	200	10	300	52	11 - 13	8	11	311	1 / 50 pcs
WR-TT0233	9 mm	200	10	300	52	12 - 13	9	12	320	1 / 50 pcs
WR-TT0234	10 mm	200	10	300	49	14 - 15	10	13	315	1 / 50 pcs
WR-TT0235	11 mm	200	10	300	52	17 - 18	11	14	330	1 / 50 pcs
WR-TT0236	12 mm	200	10	300	52	17 - 19	12	15	350	1 / 50 pcs
WR-TT0237	13 mm	200	10	300	52	18 - 21	13	15	340	1 / 50 pcs
WR-TT0238	14 mm	200	10	300	49	20 - 22	14	16	350	1 / 50 pcs
WR-TT0239	17 mm	200	10	300	52	24 - 25	17	22	372	1 / 50 pcs
WR-TT0240	19 mm	200	10	300	52	27 - 28	19	23	390	1 / 50 pcs

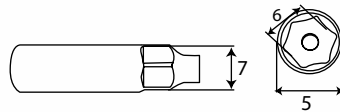

- Chrome vanadium steel on socket head
- With heat treatment for extra durability and strength
- Anti slip rubber handle

T-TYPE BOX WRENCH MATTED COATING HANDLE

T-TYPE SOCKET GAGANG KARET

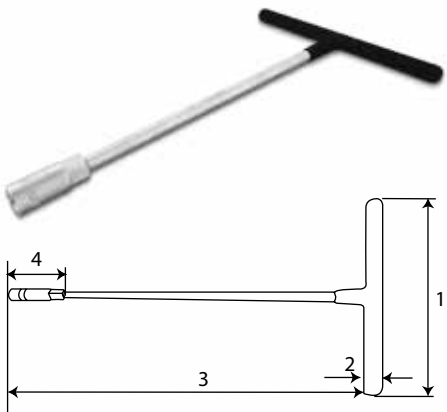

ITEM CODE	SIZE	1 (mm)	2 (mm)	3 (mm)	4 (mm)	5 (mm)	6 (mm)	7 (mm)	WEIGHT (gr)	QTY / BOX INNER/MASTER
WR-TT0241	8 mm	200	13	300	48	12 - 13	8	10	323	1 / 50 pcs
WR-TT0242	10 mm	200	13	300	48	12 - 14	10	12	336	1 / 50 pcs
WR-TT0243	11 mm	201	12	300	50	12 - 15	11	14	352	1 / 50 pcs
WR-TT0244	12 mm	200	13	300	49	12 - 15	12	15	365	1 / 50 pcs
WR-TT0245	13 mm	200	13	300	49	12 - 17	13	15	376	1 / 50 pcs
WR-TT0246	14 mm	200	13	300	50	12 - 18	14	16	379	1 / 50 pcs
WR-TT0247	17 mm	200	13	300	51	12 - 19	17	20	406	1 / 50 pcs
WR-TT0248	19 mm	201	12	300	51	12 - 26	19	23	404	1 / 50 pcs

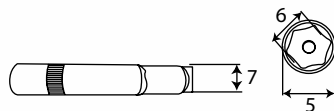

- Chrome vanadium steel on socket head
- With heat treatment for extra durability and strength
- Free rotating grip for better control and speed

T-TYPE WRENCH (ROTARY TYPE)

T-TYPE SOCKET (PUTAR)

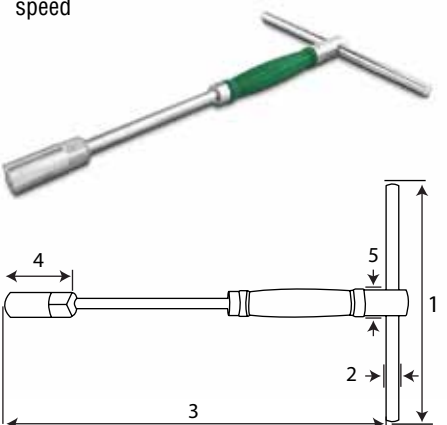

ITEM CODE	SIZE	1 (mm)	2 (mm)	3 (mm)	4 (mm)	5 (mm)	6 (mm)	7 (mm)	WEIGHT (gr)	QTY / BOX INNER/MASTER
WR-TT0249	8 mm	200	10	300	50	17	17	8	379	1 / 50 pcs
WR-TT0250	10 mm	200	10	300	50	15	13	10	394	1 / 50 pcs
WR-TT0251	11 mm	200	10	300	50	16	16	11	406	1 / 50 pcs
WR-TT0252	12 mm	200	10	300	50	16	17	12	415	1 / 50 pcs
WR-TT0253	13 mm	200	10	300	50	15	18	13	425	1 / 50 pcs
WR-TT0254	14 mm	200	10	300	50	18	19	14	430	1 / 50 pcs
WR-TT0255	17 mm	200	10	300	50	18	24	17	460	1 / 50 pcs
WR-TT0256	19 mm	200	10	300	50	17	25	19	466	1 / 50 pcs



T-TYPE ADAPTOR (ROTARY TYPE)

T-TYPE SOCKET WITH ADAPTOR (PUTAR)

ITEM CODE	SIZE	1 (mm)	2 (mm)	3 (mm)	4 (mm)	5 (mm)	WEIGHT (gr)	QTY / BOX INNER/MASTER
WR-TT0257	1/2"	200	95	175	9	12	420	1 / 50 pcs

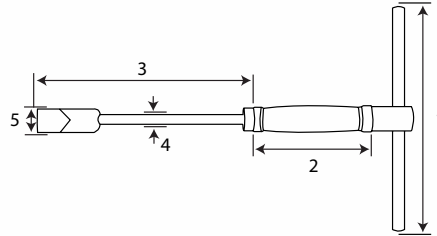

- Material is Chrome vanadium steel on head socket
- With heat treatment for extra durability and strength
- Free rotating grip for better control and speed
- 1/2" DR. Adaptor head



T-TYPE SCREWDRIVER

T-TYPE SOCKET OBENG

ITEM CODE	SIZE	1 (mm)	2 (mm)	3 (mm)	4 (mm)	5 (mm)	WEIGHT (gr)	QTY / BOX INNER/MASTER
WR-TT0258	PH2	200	97	161	6	6	171	1 / 50 pcs
WR-TT0259	PH3	200	95	170	7	7	246	1 / 50 pcs

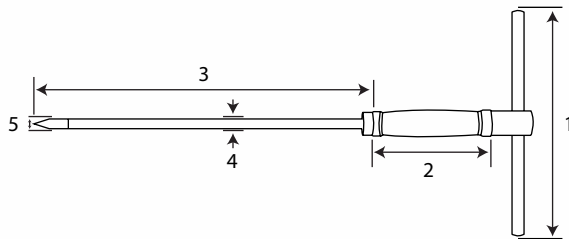

- Material is Chrome vanadium steel on head socket
- With heat treatment for extra durability and strength
- Free rotating grip for better control and speed
- Magnetic tip



T HANDLE

T-TYPE SOCKET EXTRA PANJANG

ITEM CODE	SIZE	1 (mm)	2 (mm)	3 (mm)	4 (mm)	5 (mm)	6 (mm)	WEIGHT (gr)	QTY / BOX INNER/MASTER
WR-TT0261	500 X 8 mm	199	450	47	8	18	10	470	1 / 50 pcs
WR-TT0262	500 X 10 mm	200	460	46	10	19	9	479	1 / 50 pcs
WR-TT0263	500 X 12 mm	200	460	45	15	20	9	479	1 / 50 pcs
WR-TT0264	500 X 14 mm	200	460	45	17	20	9	481	1 / 50 pcs

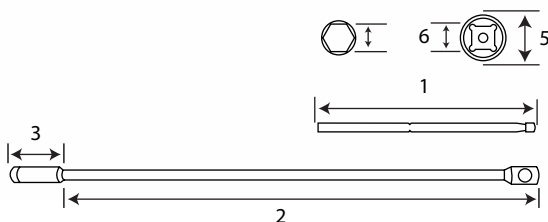

- Material is Chrome vanadium steel on head socket
- With heat treatment for extra durability and strength
- Universal joint model with removable sliding bar handle
- Extra-Long design to avoid burns from engine heat



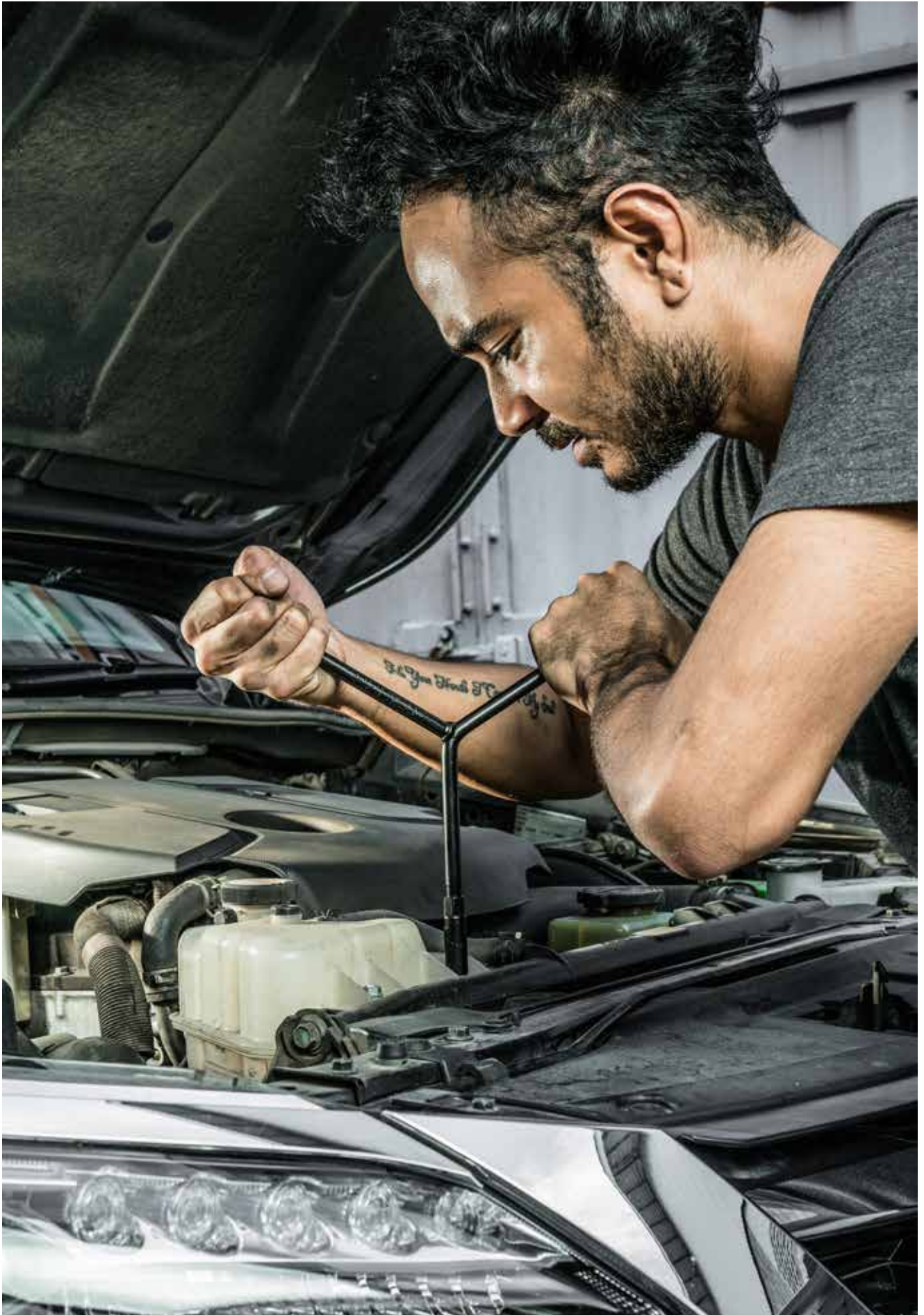

Y-SOCKET WRENCH

Y-TYPE SOCKET

ITEM CODE	SIZE	1 (mm)	2 (mm)	3 (mm)	4 (mm)	WEIGHT (gr)	QTY / BOX INNER/MASTER
WR-YT0265	08 - 09 - 10 mm	90	18	8 - 9 - 10	13 - 13 - 16	172	12 / 96 pcs
WR-YT0266	08 - 10 - 12 mm	90	18	8 - 10 - 12	13 - 16 - 19	172	12 / 96 pcs
WR-YT0267	10 - 11 - 13 mm	90	18	10 - 11 - 13	16 - 15 - 18	182	12 / 96 pcs
WR-YT0268	10 - 12 - 14 mm	90	18	10 - 12 - 14	16 - 19 - 19	193	12 / 96 pcs
WR-YT0269	12 - 14 - 17 mm	90	18	12 - 14 - 17	19 - 20 - 24	219	12 / 96 pcs

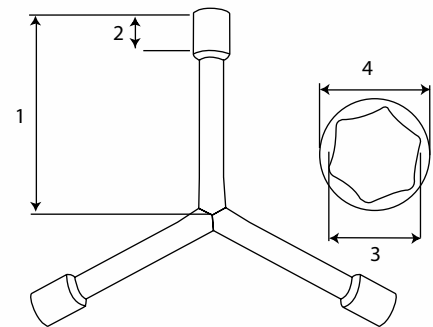

- Chrome vanadium steel on socket head
- Dropped forged

Y-TYPE WRENCH (LONG)

Y-TYPE WRENCH (PANJANG)

ITEM CODE	SIZE	1 (mm)	2 (mm)	3 (mm)	4 (mm)	WEIGHT (gr)	QTY / BOX INNER/MASTER
WR-YT0270	08 - 09 - 10 mm	144	50	8 - 9 - 10	12 - 14 - 14	290	1 / 50 pcs
WR-YT0271	08 - 10 - 12 mm	144	50	8 - 10 - 12	12 - 14 - 17	310	1 / 50 pcs
WR-YT0272	10 - 11 - 13 mm	144	50	10 - 11 - 13	14 - 16 - 18	340	1 / 50 pcs
WR-YT0273	10 - 12 - 14 mm	144	50	10 - 12 - 14	14 - 17 - 20	370	1 / 50 pcs
WR-YT0274	12 - 14 - 17 mm	144	50	12 - 14 - 17	17 - 20 - 24	400	1 / 50 pcs

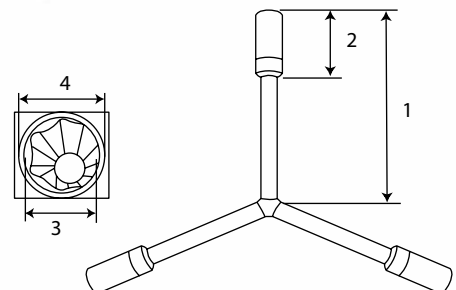

- Chrome vanadium steel on socket head
- Dropped forged
- Extra long shafts for additional leverage and torque

ADJUSTABLE WRENCHES

TEKIRO adjustable wrenches are made for Professional users. It features a large knurl worm for easy adjustment and a tight jaw fit. Its jaw design help reduces slippage and grips tightly on fasteners. The wide I-Beam handle design provides comfort for long term use. Tekiro adjustable wrenches are drop forged for increased toughness and durability.

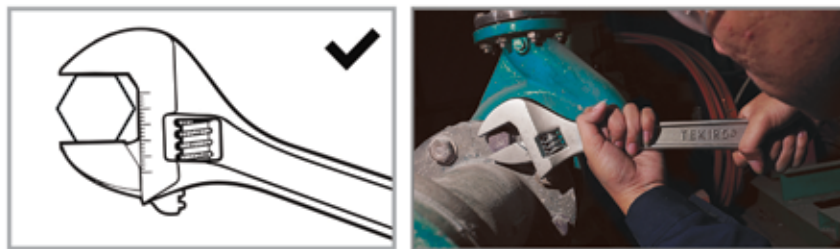
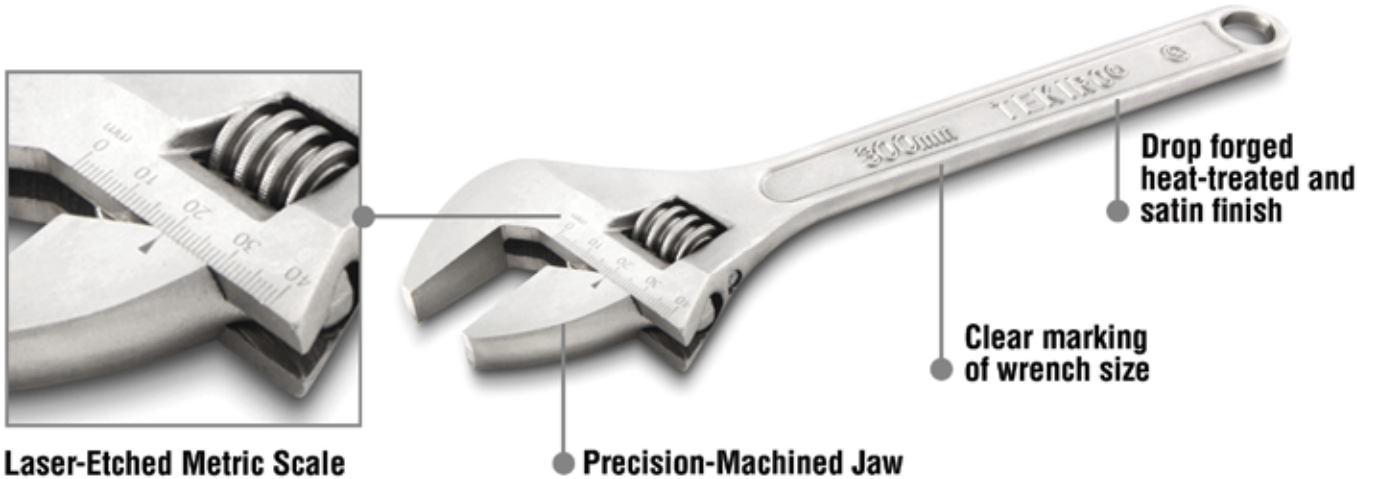

Always ensure there is positive fit onto the fastener

PIPE WRENCHES

TEKIRO Pipe Wrenches are made of one-piece ductile iron casting for heavy duty use. It features a drop forged jaw that is resistant to wear, distortion and breakage. The various sizes of its pipe wrenches are ideal for surfaces such as black, galvanized, PVC and copper pipes.





ADJUSTABLE WRENCH

KUNCI INGGRIS NEW

ITEM CODE	SIZE	1 (mm)	2 (mm)	3 (mm)	4 (mm)	5 (mm)	6 (mm)	WEIGHT (gr)	QTY / BOX INNER/MASTER
WR-AD0280	6"	150	6	12	45	19	20	140	6 / 60 pcs
WR-AD0281	8"	200	7	14	59	24	24	255	6 / 60 pcs
WR-AD0282	10"	250	7	16	70	28	29	425	6 / 36 pcs
WR-AD0283	12"	300	8	20	83	31	34	725	6 / 24 pcs
WR-AD0284	15"	375	11	23	100	39	44	1,370	6 / 12 pcs
WR-AD0285	18"	450	11	25	120	43	55	2,150	1 / 8 pcs
WR-AD0286	24"	595	14	30	412	50	62	4,370	1 / 4 pcs

- Chrome vanadium
- Dropped Forged with heat treatment for extra durability and strength
- Nickel plated finish to resist corrosion
- Laser etched scale
- Precision Machined Jaws
- Knurled Adjustment Worm

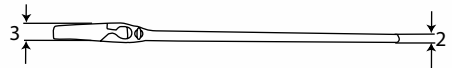
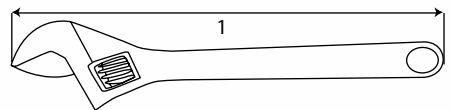

PIPE WRENCH WITHOUT RUBBER HANDLE

KUNCI PIPA

ITEM CODE	SIZE	1 (mm)	2 (mm)	3 (mm)	4 (mm)	5 (mm)	6 (mm)	7 (mm)	8 (mm)	WEIGHT (gr)	QTY / BOX INNER/MASTER
WR-PP0287	6"	77	113	13	10	40	19	12	25	200	6 / 60 pcs
WR-PP0288	8"	91	162	15	11	50	22	16	35	400	6 / 60 pcs
WR-PP0289	10"	115	217	17	14	60	26	19	40	700	6 / 36 pcs
WR-PP0290	12"	139	239	19	16	69	30	21	55	950	6 / 36 pcs
WR-PP0291	14"	158	282	21	17	74	32	23	70	1,400	6 / 24 pcs
WR-PP0292	18"	179	369	24	16	87	37	28	80	2,050	6 / 12 pcs
WR-PP0293	24"	210	470	29	23	99	40	30	90	3,550	6 / 12 pcs
WR-PP0294	36"	250	720	31	25	129	48	36	100	6,500	3 / 6 pcs
WR-PP0295	48"	316	980	33	29	160	59	46	125	11,500	2 / 4 pcs

- One piece ductile iron casted with I-Beam design for extra strength
- The full floating forged hook jaw allows for superior gripping and quick adjustments
- Hardened and tempered teeth provide excellent bite

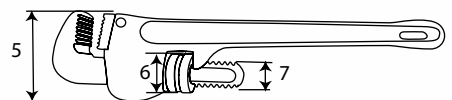
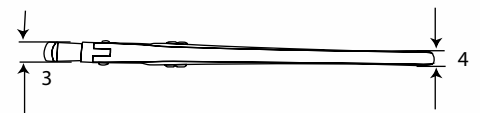
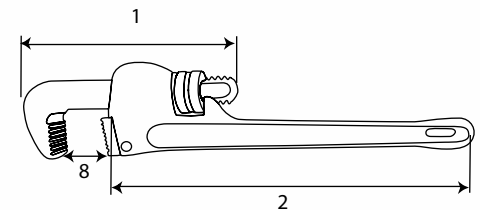

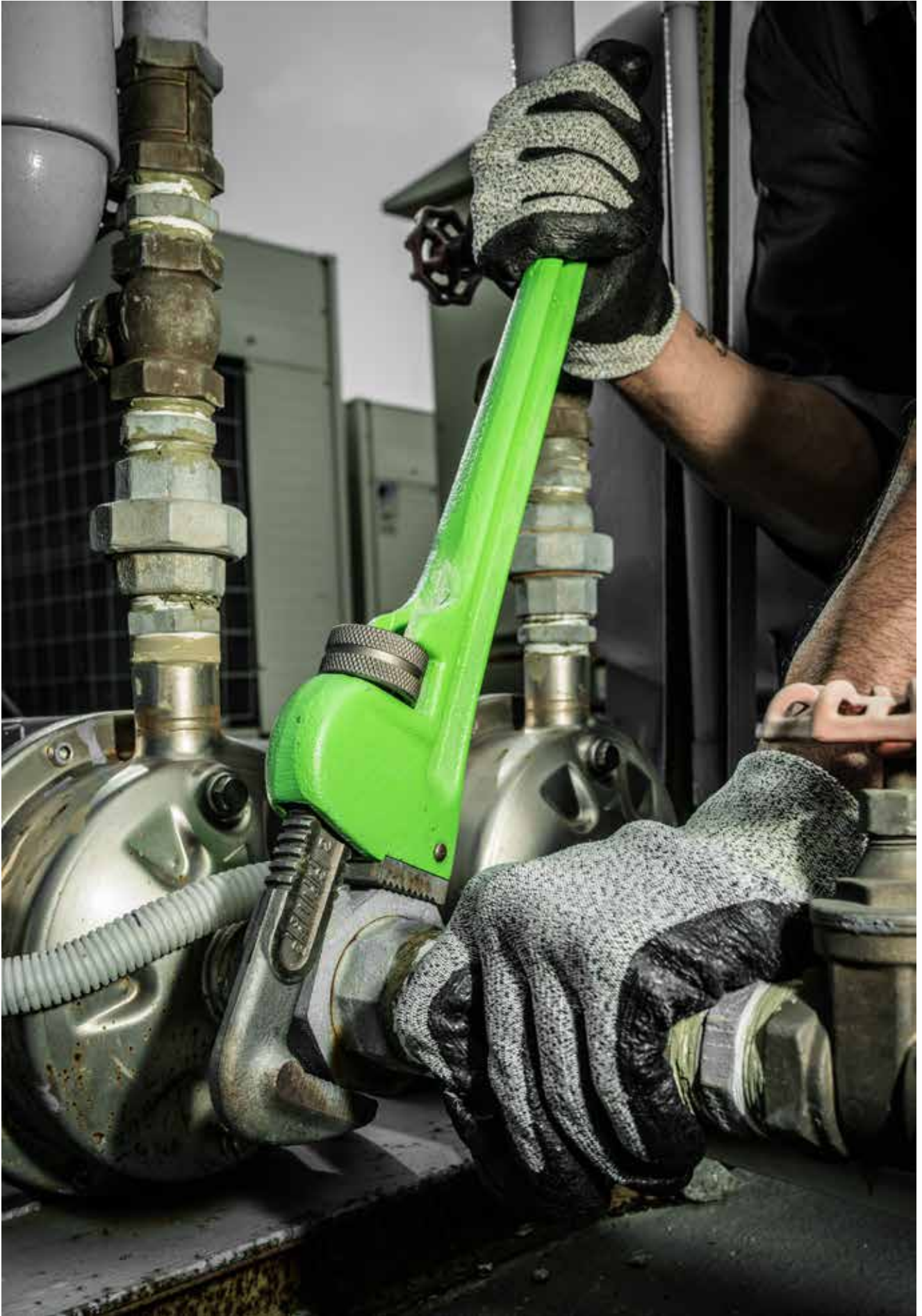

COMBINATION WRENCH SET

KUNCI RING PAS SET

ITEM CODE	SIZE	CONTENT	WEIGHT (gr)	QTY / BOX INNER/MASTER
WR-SE0296	11 pcs (8 - 24 mm)	8mm, 9 mm, 10 mm, 11 mm, 12 mm, 13 mm 14 mm, 17 mm, 19 mm, 22 mm, 24 mm	1,667	1 / 10 set
WR-SE0297	14 pcs (8 - 24 mm)	8 mm, 9 mm, 10 mm, 11 mm, 12 mm, 13 mm 14 mm, 15 mm, 16 mm, 17 mm, 19 mm, 21 mm 22 mm, 24 mm	2,101	1 / 10 set
WR-SE0298	14 pcs (8 - 32 mm)	8 mm, 9 mm, 10 mm, 11 mm, 12 mm, 13 mm 14 mm, 17 mm, 19 mm, 22 mm, 24 mm, 27 mm 30 mm, 32 mm	3,778	1 / 6 set
WR-SE0299	11 pcs (5/16" - 1")	5/16", 3/8", 7/16", 1/2", 9/16", 5/8", 11/16", 3/4" 13/16", 7/8", 1"	1,992	1 / 10 set
WR-SE0300	14 pcs (3/8"-1 1/4")	3/8", 7/16", 1/2", 9/16", 5/8", 11/16", 3/4", 13/16" 7/8", 15/16", 1", 1 1/8", 1 1/8", 1 1/4"	4,481	1 / 6 set

- Set comes with a heavy duty storage pouch
- Raised panel wrench design provides better strength and grip



BOX END WRENCH SET

KUNCI RING SET

ITEM CODE	SIZE	CONTENT	WEIGHT (gr)	QTY / BOX INNER/MASTER
WR-SE0301	8 pcs (6 - 24 mm)	6 X 7 mm, 8 X 9 mm, 10 X 11 mm 12 X 13 mm, 14 X 15 mm, 16 X 17 mm 19 X 21 mm, 22 X 24 mm	1,064	1 / 10 set
WR-SE0302	12 pcs (6 - 32 mm)	6 X 7 mm, 8 X 9 mm, 10 X 11 mm 12 X 13 mm, 14 X 15 mm, 16 X 17 mm 19 X 21 mm, 21 X 23 mm, 22 X 24 mm 24 X 27 mm, 25 X 28 mm, 30 X 32 mm	3,833	1 / 6 set
WR-SE0303	8 pcs (1/4" - 1 1/4")	1/4" X 5/16", 3/8" X 7/16", 1/2" X 9/16" 5/8" X 11/16", 3/4" X 13/16", 7/8" X 15/16" 1 X 1 1/8", 1 1/8" X 1 1/4"	2,767	1 / 6 set
WR-SE0304	8 pcs 75 degree (6 - 24 mm)	6 X 7 mm, 8 X 9 mm, 10 X 11 mm 12 X 13 mm, 14 X 15 mm, 16 X 17 mm 19 X 21 mm, 22 X 24 mm	1,690	1 / 10 set

- Set comes with a heavy duty storage pouch
- Raised panel wrench design provides better strength and grip
- Offset at 45° for ease of access



OPEN END WRENCH SET

KUNCI PAS SET

ITEM CODE	SIZE	CONTENT	WEIGHT (gr)	QTY / BOX INNER/MASTER
WR-SE0305	8 pcs (6 - 24 mm)	6 X 7 mm, 8 X 9 mm, 10 X 11 mm 12 X 13 mm, 14 X 15 mm, 16 X 17 mm 19 X 21 mm, 22 X 24 mm	1,042	1 / 10 set
WR-SE0306	12 pcs (6 - 32 mm)	6 X 7 mm, 8 X 9 mm, 10 X 11 mm 12 X 13 mm, 14 X 15 mm, 16 X 17 mm 19 X 21 mm, 21 X 23 mm, 22 X 24 mm 24 X 27 mm, 25 X 28 mm, 30 X 32 mm	3,050	1 / 10 set
WR-SE0307	8 pcs (1/4" - 1 1/4")	1/4" X 5/16", 3/8" X 7/16", 1/2" X 9/16" 3/8" X 11/16", 3/4" X 13/16" 7/8" X 15/16", 1 X 1 1/8", 1 1/8" X 1 1/4"	2,161	1 / 10 set

- Set comes with a heavy duty storage pouch
- Raised panel wrench design provides better strength and grip



WRENCH

TORQUE

SOCKET

IMPACT SOCKET

PLIER

SCREWDRIVER

- Set comes with a heavy duty storage pouch
- Sunk Panel type with Silver Matt Finish
- Dropped forged Chrome Vanadium Material



COMBINATION WRENCH SET - SUNK PANEL

KUNCI RING PAS SET - SUNK PANEL

ITEM CODE	SIZE	CONTENT	WEIGHT (gr)	QTY / BOX INNER/MASTER
WR-SE0308	11 pcs (8 - 24 mm)	8 mm, 9 mm, 10 mm, 11 mm	1,450	1 / 10 set
		12 mm, 13 mm, 14 mm, 17 mm		
		17 mm, 19 mm, 22 mm, 24 mm		
WR-SE0309	14 pcs (8 - 24 mm)	8 mm, 9 mm, 10 mm, 11 mm	1,650	1 / 10 set
		12 mm, 13 mm, 14 mm, 15 mm		
		16 mm, 17 mm, 19 mm, 21 mm		
		22 mm, 24 mm		
WR-SE0310	14 pcs (8 - 32 mm)	8 mm, 9 mm, 10 mm, 11 mm	3,766	1 / 6 set
		12 mm, 13 mm, 14 mm, 17 mm		
		19 mm, 22 mm, 24 mm, 27 mm		
		30 mm, 32 mm		

- Set comes with a heavy duty storage pouch
- Offset at 45° for ease of access
- Sunk Panel type with Silver Matt Finish
- Dropped forged Chrome Vanadium Material



BOX END WRENCH SET - SUNK PANEL

KUNCI RING SET - SUNK PANEL

ITEM CODE	SIZE	CONTENT	WEIGHT (gr)	QTY / BOX INNER/MASTER
WR-SE0311	8 pcs (6 - 24 mm)	6 X 7 mm, 8 X 9 mm, 10 X 11 mm	1,690	1 / 10 set
		12 X 13 mm, 14 X 15 mm, 16 X 17 mm		
		19 X 21 mm, 22 X 24 mm		
WR-SE0312	12 pcs (6 - 32 mm)	6 X 7 mm, 8 X 9 mm, 10 X 11 mm	2,817	1 / 6 set
		12 X 13 mm, 14 X 15 mm, 16 X 17 mm		
		19 X 21 mm, 21 X 23 mm, 22 X 24 mm		
		24 X 27 mm, 25 X 28 mm, 30 X 32 mm		

- Set comes with a heavy duty storage pouch
- Sunk Panel type with Silver Matt Finish
- Dropped forged Chrome Vanadium Material



OPEN END WRENCH SET - SUNK PANEL

KUNCI PAS SET - SUNK PANEL

ITEM CODE	SIZE	CONTENT	WEIGHT (gr)	QTY / BOX INNER/MASTER
WR-SE0313	8 pcs (6 - 24 mm)	6 X 7 mm, 8 X 9 mm, 10 X 11 mm	1,200	1 / 10 set
		12 X 13 mm, 14 X 15 mm, 16 X 17 mm		
		19 X 21 mm, 22 X 24 mm		
WR-SE0314	12 pcs (6 - 32 mm)	6 X 7 mm, 8 X 9 mm, 10 X 11 mm	2,700	1 / 8 set
		12 X 13 mm, 14 X 15 mm, 16 X 17 mm		
		19 X 21 mm, 21 X 23 mm, 22 X 24 mm		
		24 X 27 mm, 25 X 28 mm, 30 X 32 mm		

STAR WRENCH SET 6 PCS

KUNCI RING BINTANG SET 6 PCS

ITEM CODE	SIZE	CONTENT	WEIGHT (gr)	QTY / BOX INNER/MASTER
WR-SR0315	6 pcs (E6 - E24)	E6 X E8, E7 X E11, E10 X E12 E14 X E18, E16 X E22, E20 X E24	1,120	1 / 10 set

- Set comes with a heavy duty metal case
- Sunk Panel type with Silver Matt Finish
- Dropped forged Chrome Vanadium Material



OBSTRUCTION WRENCH SET

KUNCI RING BULAN SET

ITEM CODE	SIZE	CONTENT	WEIGHT (gr)	QTY / BOX INNER/MASTER
WR-OS0316	5 pcs (10 - 22 mm)	10 X 12 mm, 11 X 13 mm, 14 X 17 mm 16 X 18 mm, 19 X 22 mm	901	1 / 16 set

- Chrome Vanadium material
- Drop Forged for extra strength
- Polished finished
- Set comes with a heavy duty tray



BIKE TOOLKIT SET 6 PCS

KUNCI SEPEDA SET 6 PCS

ITEM CODE	CONTENT	WEIGHT (gr)	QTY / BOX INNER/MASTER
WR-BK0317	4 pcs Hex Key 3 mm, 4 mm, 5 mm, 6 mm	192	10 / 60 set
	1 pcs Torx Key T25		
	1 pcs Screwdriver Tip PH #2		

- Heat Treated
- Hardened and tempered
- Chrome Vanadium steel
- Placed in the pouch bag, easy to carry



WRENCH

TORQUE

SOCKET

IMPACT SOCKET

PLIER

SCREWDRIVER

- Heat Treated
- Hardened and tempered
- Chrome Vanadium steel
- Placed in the pouch bag, easy to carry



BIKE TOOLKIT SET 10 PCS

KUNCI SEPEDA SET 10 PCS

ITEM CODE	CONTENT		WEIGHT (gr)	QTY / BOX INNER/MASTER
WR-BK0318	7 pcs	Hex Key 2 mm, 2.5 mm, 3 mm, 4 mm, 5 mm 6 mm, 8 mm	233	10 / 60 set
	1 pcs	Torx Key T25		
	2 pcs	Screwdriver Tip Slotted 5 mm, PH #2		

- Heat Treated
- Hardened and tempered
- Chrome Vanadium steel
- Placed in the pouch bag, easy to carry



BIKE TOOLKIT SET 15 PCS

KUNCI SEPEDA SET 15 PCS

ITEM CODE	CONTENT		WEIGHT (gr)	QTY / BOX INNER/MASTER
WR-BK0319	7 pcs	Hex Key 2 mm, 2.5 mm, 3 mm, 4 mm, 5 mm 6 mm, 8 mm	300	10 / 40 set
	2 pcs	Torx Key T10, T25		
	1 pcs	Screwdriver Tip Flat 5 mm, PH #2		
	4 pcs	Chain Wrench + Screw Spoke Wrench 14 G, 15 G, 0.136"		

- Chrome vanadium
- Chrome nickel plated finishing
- Drop forged
- thin wall ideal for fastening and loosening coupling nuts

COUPLING NUT WRENCH

KUNCI BLOK MESIN

ITEM CODE	SIZE	1 (mm)	2 (mm)	3 (mm)	4 (mm)	5 (mm)	6 (mm)	7 (mm)	WEIGHT (gr)	QTY / BOX INNER/MASTER
WR-CN1456	39 X 41	270	39	41	62	62	24	4	403	6 / 36 pcs

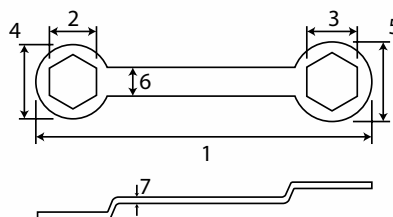

DOUBLE SWIVEL WRENCH

KUNCI SOCK GANDA FLEXIBLE

ITEM CODE	SIZE	1 (mm)	2 (mm)	3 (mm)	WEIGHT (gr)	QTY / BOX INNER/MASTER
WR-DS1594	8 X 10 mm (12 pt)	200	9	13	90.5	12 / 120 pcs
WR-DS1595	10 X 12 mm (12 pt)	220	11	14	124.5	12 / 120 pcs
WR-DS1596	12 X 14 mm (12 pt)	236	14	18	177.0	12 / 120 pcs
WR-DS1597	14 X 17 mm (12 pt)	250	16	20	220.5	12 / 60 pcs

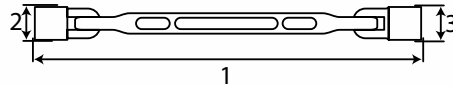

- Chrome vanadium material
- Drop forged for extra strength
- 12 pt polished socket head
- Body, silver matt finishing
- Swivel head for easy access to tight and narrow space



COMBINATION WRENCH SET 4 PCS

KUNCI RING PAS SET 4 PCS

ITEM CODE	SIZE	SIZE	WEIGHT (gr)	QTY / BOX INNER/MASTER
WR-SE1643	4 pcs	Combination Wrench 10 mm	374	5 / 50 set
		Combination Wrench 12 mm		
		Combination Wrench 14 mm		
		Combination Wrench 17 mm		

- Set comes with a heavy duty storage pouch
- Raised panel wrench design provides better strength and grip



COMBINATION WRENCH SET 8 PCS

KUNCI RING PAS SET 8 PCS

ITEM CODE	SIZE	SIZE	WEIGHT (gr)	QTY / BOX INNER/MASTER
WR-SE1644	8 pcs	Combination Wrench 8 mm	678	1 / 20 set
		Combination Wrench 10 mm		
		Combination Wrench 11 mm		
		Combination Wrench 12 mm		
		Combination Wrench 13 mm		
		Combination Wrench 14 mm		
		Combination Wrench 17 mm		
		Combination Wrench 19 mm		

- Set comes with a heavy duty storage pouch
- Raised panel wrench design provides better strength and grip



WRENCH

TORQUE

SOCKET

IMPACT SOCKET

PLIER

SCREWDRIVER

- Set comes with a heavy duty storage pouch
- Raised panel wrench design provides better strength and grip
- Offset at 45° for ease of access and feature



BOX END WRENCH SET 3 PCS

KUNCI RING SET 3 PCS

ITEM CODE	SIZE	CONTENT	WEIGHT (gr)	QTY / BOX INNER/MASTER
WR-SE1645	3 pcs	Box End Wrench 10 X 11 mm	409	5 / 50 set
		Box End Wrench 12 X 13 mm		
		Box End Wrench 14 X 15 mm		

- Set comes with a heavy duty storage pouch
- Raised panel wrench design provides better strength and grip
- Offset at 45° for ease of access and feature



BOX END WRENCH SET 5 PCS

KUNCI RING SET 5 PCS

ITEM CODE	SIZE	CONTENT	WEIGHT (gr)	QTY / BOX INNER/MASTER
WR-SE1646	5 pcs	Box End Wrench 8 X 9 mm	791	1 / 20 set
		Box End Wrench 10 X 11 mm		
		Box End Wrench 12 X 13 mm		
		Box End Wrench 14 X 15 mm		
		Box End Wrench 17 X 19 mm		

- Set comes with a heavy duty storage pouch
- Raised panel wrench design provides better strength and grip



OPEN END WRENCH SET 3 PCS

KUNCI PAS SET 3 PCS

ITEM CODE	SIZE	CONTENT	WEIGHT (gr)	QTY / BOX INNER/MASTER
WR-SE1647	3 pcs	Open End Wrench 10 X 11 mm	256	5 / 50 set
		Open End Wrench 12 X 13 mm		
		Open End Wrench 14 X 15 mm		

OPEN END WRENCH SET 5 PCS

KUNCI PAS SET 5 PCS

ITEM CODE	SIZE	CONTENT	WEIGHT (gr)	QTY / BOX INNER/MASTER
WR-SE1648	5 pcs	Open End Wrench 8 X 9 mm	491	1 / 20 set
		Open End Wrench 10 X 11 mm		
		Open End Wrench 12 X 13 mm		
		Open End Wrench 14 X 15 mm		
		Open End Wrench 17 X 19 mm		

- Set comes with a heavy duty storage pouch
- Raised panel wrench design provides better strength and grip



T-TYPE BOX WRENCH SET 3 PCS 8-10-12 MM

T-TYPE SOCKET SET 3 PCS 8-10-12 MM

ITEM CODE	SIZE	CONTENT	WEIGHT (gr)	QTY / BOX INNER/MASTER
WR-TT1871	3	T-Type Socket 8 mm	165	1 / 10 Sets
		T-Type Socket 10 mm		
		T-Type Socket 12 mm		

- Chrome vanadium steel on socket head
- Heat treated for extra durability and strength



HOOK WRENCH

KUNCI KOMSTIR DAN KNALPOT FLEXIBLE

ITEM CODE	SIZE	1 (mm)	2 (mm)	3 (mm)	4 (mm)	WEIGHT (gr)	QTY / BOX INNER/MASTER
WR-HW1848	3/4" - 2"	109	54	8	6	126	20 / 120 pcs
WR-HW1849	1 1/4" - 3"	134	69	6	10	235.5	10 / 80 pcs
WR-HW1850	2" - 4 3/4"	190	97	8	11	450	10 / 40 pcs

- Material is Chrome vanadium steel with heat treatment for extra durability and strength
- Used to tighten side slot nuts on collars, lock nuts and bearings
- Convenient and easy to use

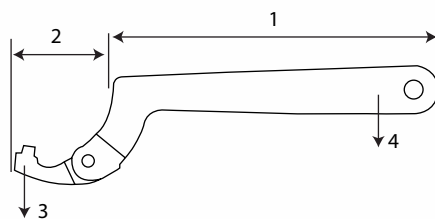



- For adjusting nuts on machines, motorbike shocks, car adjustable shocks and anything with castle style nuts

WRENCH D

WRENCH D

ITEM CODE	SIZE	1 (mm)	2 (mm)	3 (mm)	WEIGHT (gr)	QTY / BOX INNER/MASTER
SA-YH1337	164 X 43 X 17 mm	164	43	17	198	5 / 50 pcs

HOW TO USE

