

Superior Clamping and Gripping



Product Information

Sealed universal gripper DPZ-plus 125

DPZ-plus

Sealed universal gripper

Fully encapsulated. Reliable. Precise.

Sealed gripper DPZ-plus

Despite the high moment load of the base jaws, this sealed 3-finger centric gripper meets the requirements of IP67 and does not permit the ingress of any substances from the working environment into the interior of the component.

Field of application

The gripper is ideally suitable for handling of rough or dirty workpieces. Its field of application extends from the loading and unloading of machines, such as in the case of sanitary blocks, grinding machines, lathes or milling machines, to handling tasks in painting plants, in powder-processing or underwater.

Advantages – Your benefits

Robust interior multi-tooth guidance for the precise handling of different workpieces

Lip seal at the outside round guidance for permanent, secure gripper sealing

High maximum moments possible suitable for using long gripper fingers

Sealed 3-finger centric gripper complies to IP67 requirements despite a high moment load

Fastening at one gripper side in two screw directions for universal and flexible gripper assembly

Maximum gripping forces at a compact design for a wide range of applications

Air supply via hose-free direct connection or screw connections for flexible pressure supply in all automated systems

Compact dimensions for minimal interfering contours in handling

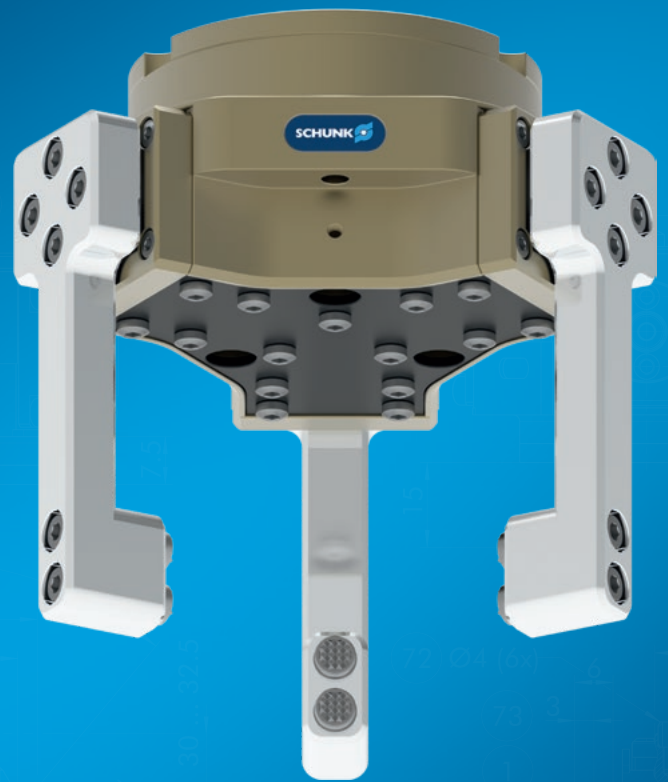

Sizes
Quantity: 8



Weight
0.2 .. 20.1 kg



Gripping force
230 .. 16500 N



Stroke per jaw
2 .. 25 mm



Workpiece weight
1.15 .. 60 kg

Functional description

The piston is moved up and down by compressed air.
The angled active surfaces of the wedge-hook produce a synchronized, centric jaw movement.

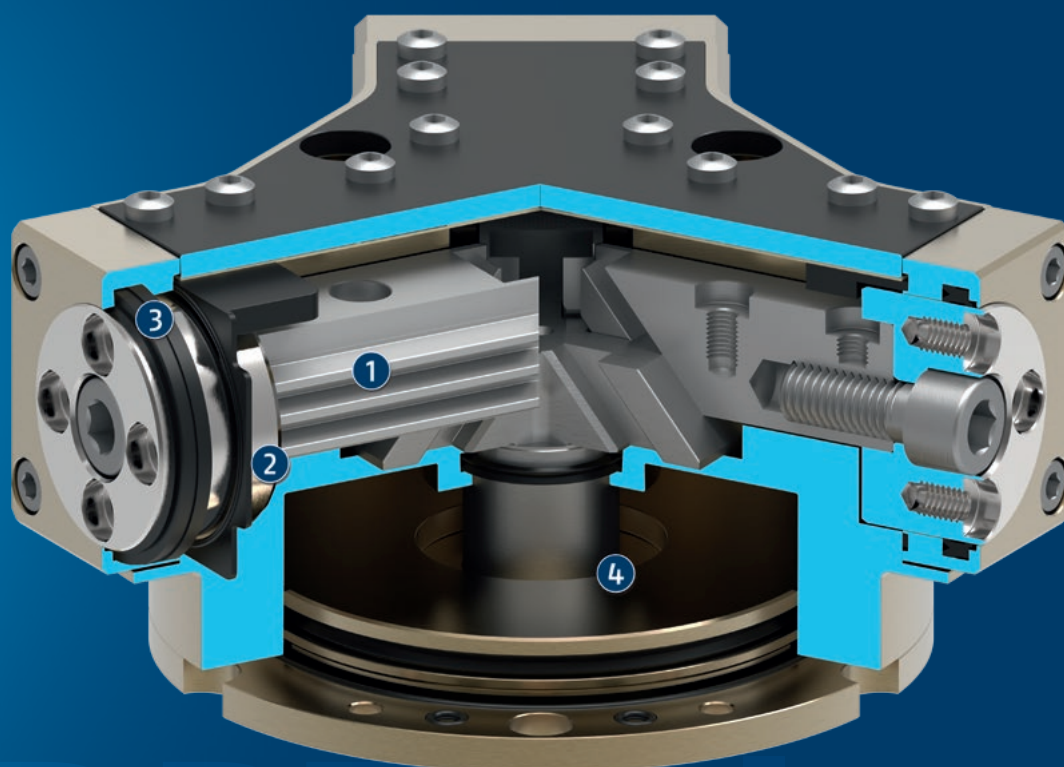

- ① **Inner base jaw with multi-tooth guidance**
for high moment loads
- ② **External round base jaw**
providing a sealable, round surface
- ③ **Lip seal**
for permanent, secure gripper sealing
- ④ **Round piston with rod and wedge-hook**
for power generation

DPZ-plus

Sealed universal gripper

General notes about the series

Operating principle: Wedge-hook kinematics

Housing material: Aluminum alloy, anodized

Base jaw material: Steel

Actuation: pneumatic, with filtered compressed air as per ISO 8573-1:2010 [7:4:4].

Warranty: 36 months

Scope of delivery: Centering sleeves, centering pins, O-rings for direct connection, assembly instructions (operating manual with declaration of incorporation is available online)

Gripping force maintenance device: possible by using the version with mechanical gripping force maintenance or pressure maintenance valve SDV-P

Finger length: is measured from the reference surface as the distance P in direction to the main axis. The maximum permissible finger length applies until the nominal operating pressure is achieved. With higher pressures, the finger length must be reduced proportionally to the nominal operating pressure.

Note – tightness: Please note that to achieve an IP 67 protection class, the gripper requires an additional hose for ventilation or a switchable air purge connection. For detailed information, please refer to the assembly and operating manual. Alternatively, a sinter filter (supplied) mounted on the air purge connection can prevent the penetration of dirt particles > 0.12 mm. However, this reduces the protection class to IP 54.

Gripping force: is the arithmetic sum of the individual force applied to each jaw at distance P (see illustration).

Repeat accuracy: is defined as a distribution of the end Position for 100 consecutive strokes.

Workpiece weight: is calculated for force-fit gripping with a coefficient of static friction of 0.1 and a safety factor of 2 against workpiece slippage at acceleration due to gravity g. For form-fit or capture gripping, there are significantly higher permissible workpiece weights.

Closing and opening times: are purely the times that the base jaws or fingers are in motion. Valve switching times, hose fill times, or PLC reaction times are not included, and are to be considered when cycle times are calculated.

Application example

Insertion tool for assembly of small to medium-sized workpieces. The tool can be used in both clean and dirty environments. Due to its quick-change system, other tools can alternately be fixed to the robot flange.

- 1 3-finger centric gripper DPZ-plus
- 2 Quick-change system SWS



SCHUNK offers more ...

The following components make the product even more productive – the suitable addition for the highest functionality, flexibility, reliability, and controlled production.



Compensation unit

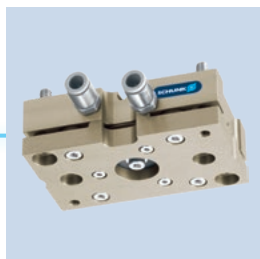

Tolerance compensation unit



Pressure maintenance valve



Universal intermediate jaw



Magnetic switches



Intermediate jaw



Jaw quick-change system

① For more information on these products can be found on the following product pages or at schunk.com.

Options and special information

Gripping force maintenance version AS/IS: The mechanical gripping force maintenance version ensures minimum gripping force even in the event of a pressure drop. In the AS/S version this acts as a closing force, in the IS version as an opening force.

Power booster version KVZ: if higher gripping forces are required

ATEX version EX: for explosive environments

Additional versions: Various options can be combined with each other. Numerous additional options are also available – just tell us what your task is!

Integrated air purge connection: impedes the ingress of dirt into the inside of the gripper

Please note that to achieve an IP 67 protection class, the gripper requires an additional hose for ventilation or a switchable air purge connection. For detailed information, please refer to the assembly and operating manual. Alternatively, a sinter filter (supplied) mounted on the air purge connection can prevent the penetration of dirt particles > 0.12 mm. However, this reduces the protection class to IP 54.

DPZ-plus 125

Sealed universal gripper

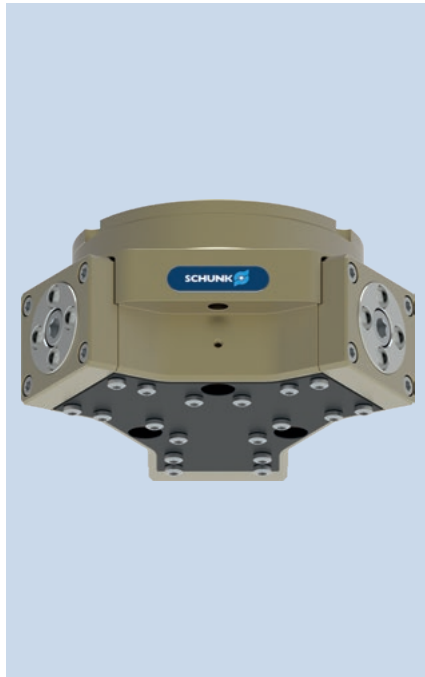

Gripping force O.D. gripping

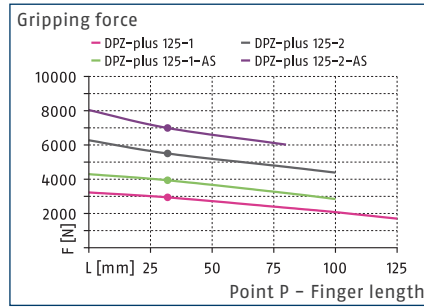

Gripping force I.D. gripping

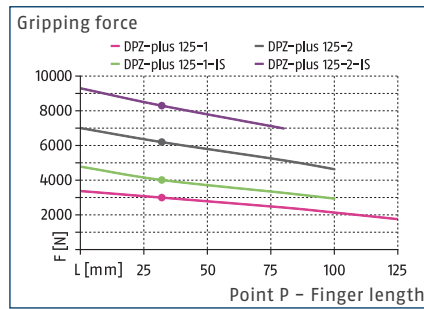

Dimensions and maximum loads

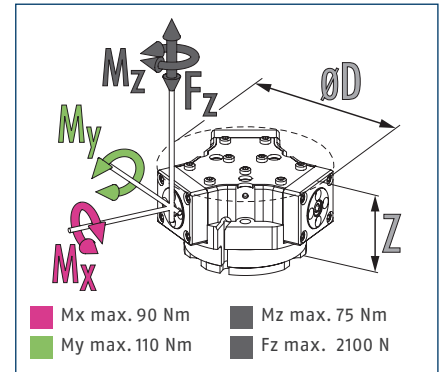

ⓘ The indicated moments and forces are static values, apply for each base jaw and may appear simultaneously. Loads may additionally occur to the moment produced by the gripping force itself.

Technical data

Description		DPZ-plus 125-1	DPZ-plus 125-2	DPZ-plus 125-1-AS	DPZ-plus 125-2-AS	DPZ-plus 125-1-IS	DPZ-plus 125-2-IS
ID		0304441	0304442	0304443	0304444	0304445	0304446
Stroke per jaw	[mm]	13	6	13	6	13	6
Closing/opening force	[N]	2945/3000	5510/6200	3940/-	7000/-	-/4015	-/8300
Min. spring force	[N]			995	1490	1015	2100
Weight	[kg]	3.5	3.5	4.7	4.7	4.7	4.7
Recommended workpiece weight	[kg]	14.7	27.5	14.7	27.5	14.7	27.5
Fluid consumption double stroke	[cm³]	230	230	383	383	383	383
Min./nom./max. operating pressure	[bar]	2.5/6/8	2.5/6/8	4/6/6.5	4/6/6.5	4/6/6.5	4/6/6.5
Min./max. air purge pressure	[bar]	0.2/0.5	0.2/0.5	0.2/0.5	0.2/0.5	0.2/0.5	0.2/0.5
Closing/opening time	[s]	0.25/0.25	0.25/0.25	0.22/0.45	0.22/0.45	0.45/0.22	0.45/0.22
Max. permissible finger length	[mm]	125	100	100	80	100	80
Max. permissible mass per finger	[kg]	1.75	1.75	1.75	1.75	1.75	1.75
IP protection class		67	67	67	67	67	67
Min./max. ambient temperature	[°C]	5/90	5/90	5/90	5/90	5/90	5/90
Repeat accuracy	[mm]	0.01	0.01	0.01	0.01	0.01	0.01
Cleanroom class ISO 14644-1:1999		5	5	5	5	5	5
Dimensions Ø D x Z	[mm]	172.2 x 76.2	172.2 x 76.2	172.2 x 101.15	172.2 x 101.15	172.2 x 101.15	172.2 x 101.15

ⓘ Please note that to achieve an IP 67 protection class, the gripper requires an additional hose for ventilation or a switchable air purge connection. For detailed information, please refer to the assembly and operating manual. Alternatively, a sinter filter (supplied) mounted on the air purge connection can prevent the penetration of dirt particles > 0.12 mm. However, this reduces the protection class to IP 54. It may take a few 100 gripping cycles until the full gripping force (as indicated in the data table) will be available.

Main view

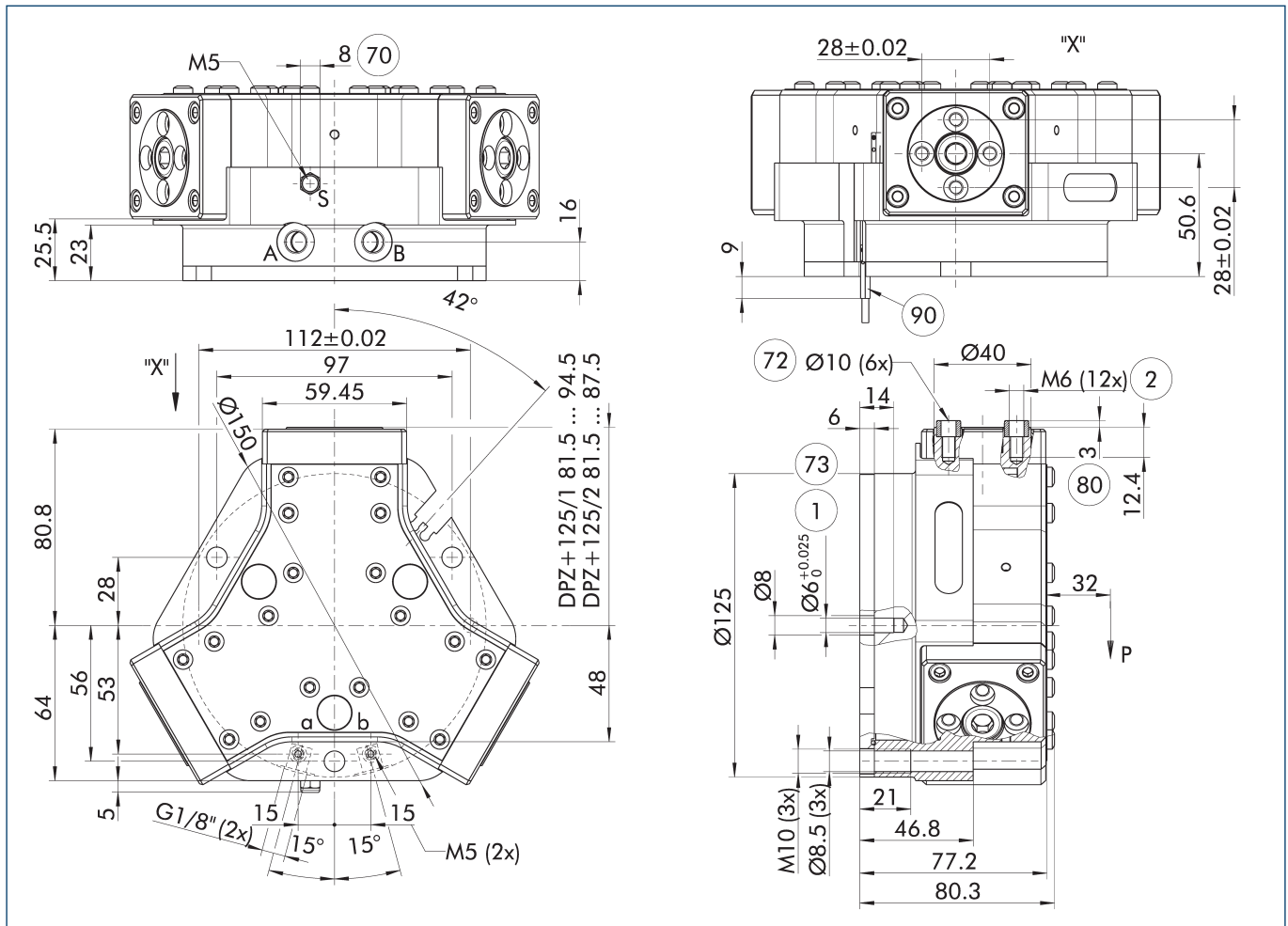

For finger connection, we recommend only to use two of the four centering bores for each finger. The drawing shows the gripper in the basic version with closed jaws, the dimensions do not include the options described below.

① The SDV-P pressure maintenance valve can also be used for I.D. or O.D. gripping alternatively or in addition to the spring-loaded, mechanical gripping force maintenance device (see catalog section on accessories).

- A, a Main / direct connection, gripper opening
- B, b Main / direct connection, gripper closing
- S, E Air purge connection, or deaeration bore
- ① Gripper connection

- ② Finger connection
- ⑦ Wrench size
- ⑦ Fit for centering sleeves
- ⑦ Fit for centering pins
- ⑧ Depth of the centering sleeve hole in the counter part
- ⑨ Sensor MMS 22..

DPZ-plus 125

Sealed universal gripper

Hose-free direct connection M5

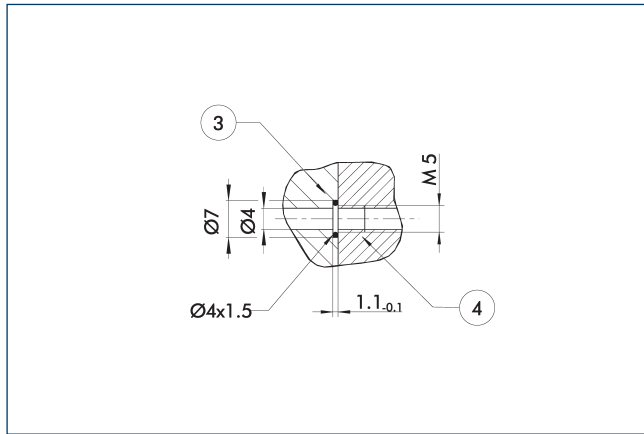

③ Adapter

④ Grippers

The direct connection is used for supplying compressed air without hoses. Instead, the pressure medium is fed through bore-holes in the mounting plate.

Connect the air purge connection

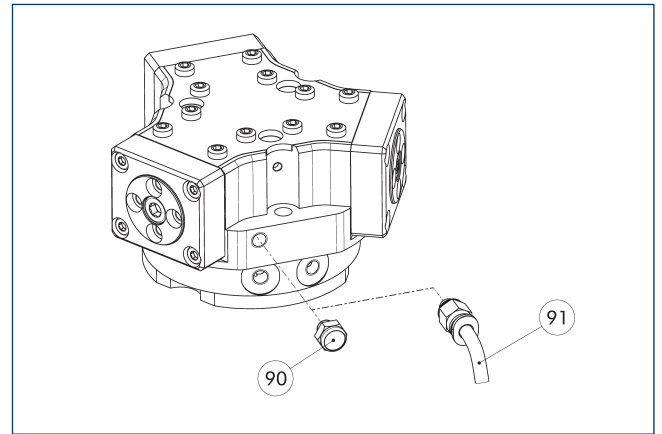

⑨⑩ Sinter filter

⑨① Hose for ventilation or air purge connection

Please note that to achieve an IP 67 protection class, the gripper requires an additional hose for ventilation or a switchable air purge connection. For detailed information, please refer to the assembly and operating manual. Alternatively, a sinter filter (supplied) mounted on the air purge connection can prevent the penetration of dirt particles > 0.12 mm. However, this reduces the protection class to IP 54.

Gripping force maintenance device AS / IS

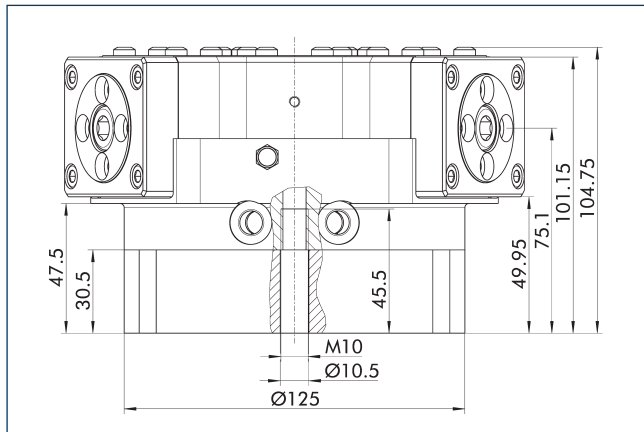

The mechanical gripping force maintenance device ensures that a minimum clamping force will be applied even if there is a drop in pressure. This acts as closing force in the AS / S version, and as opening force in the IS version. Besides this, the gripping force maintenance device can be used to increase the gripping force or for single actuated gripping.

Proposed jaw design

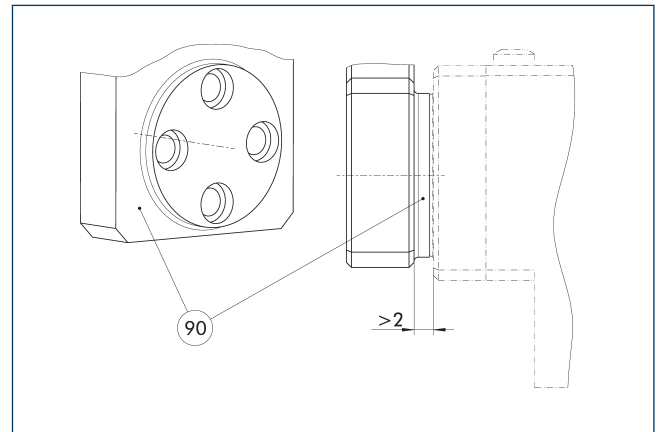

⑨⑩ Step

In order to avoid impairment of the stroke due to contamination or chips, there should be a sufficient distance between the top jaws and the gripper.

Spring-loaded pressure piece

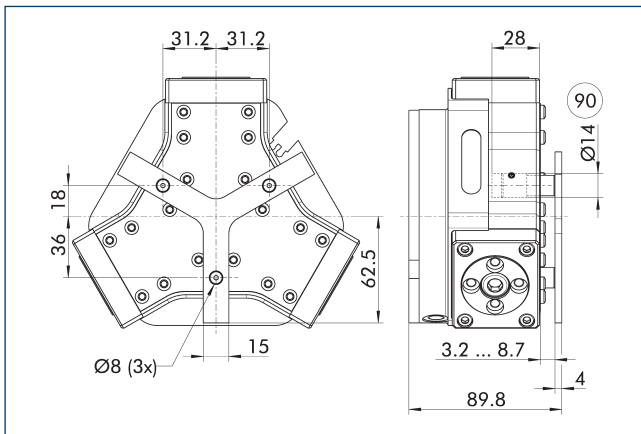

90 Guide pin

For spring-supported positioning of the workpiece against a stop after the gripper has opened. Especially developed for loading machines.

Description	ID	Stroke [mm]	Min. force [N]
Spring-loaded pressure piece			
A-PZN-plus/DPZ-plus 125	0303723	5.5	105

SDV-P pressure maintenance valve

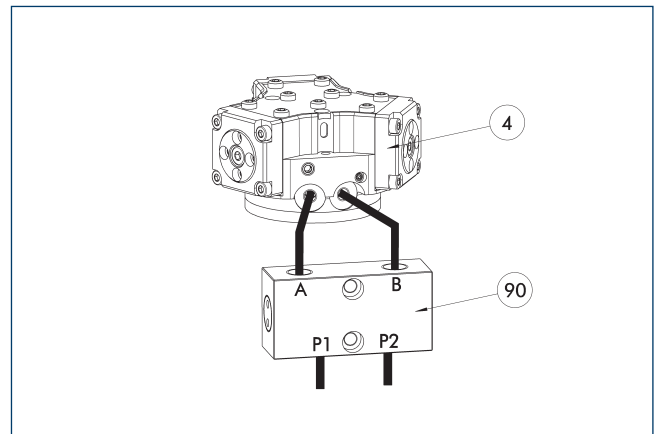

4 Grippers

90 SDV-P pressure maintenance valve

The SDV-P pressure maintenance valve ensures in emergency STOP situations that the pressure in the piston chamber of pneumatic gripper, swivel, linear, and quick-change modules is temporarily maintained.

Description	ID	Recommended hose diameter [mm]
Pressure maintenance valve		
SDV-P 04	0403130	6
SDV-P 07	0403131	8
Pressure maintenance valve with air bleed screw		
SDV-P 04-E	0300120	6
SDV-P 07-E	0300121	8

① In order to achieve the specified closing and opening time for each gripper variant, the recommended hose diameter must be used. The direct allocation of the respective variant of the gripper for the respective SDV-P can be found at schunk.com.

Intermediate jaw interface

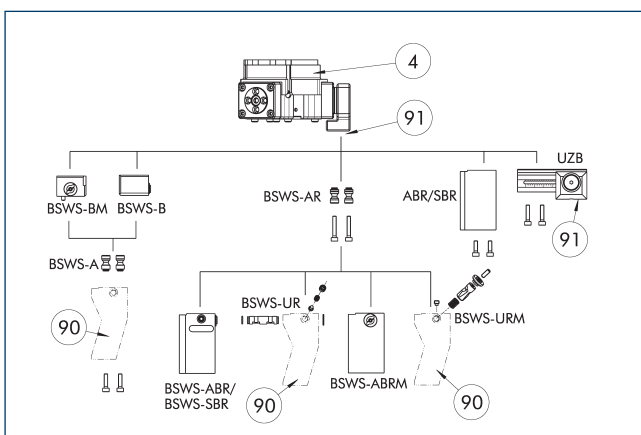

4 Grippers

91 Uniform screw connection pattern

90 Customized gripper fingers

By using the intermediate jaw, you have the possibility of directly connecting a wide range of accessories directly. This includes jaw quick-change systems, finger blanks, and universal intermediate jaws.

ZBA DPG-plus/DPZ-plus 125-100 intermediate jaw

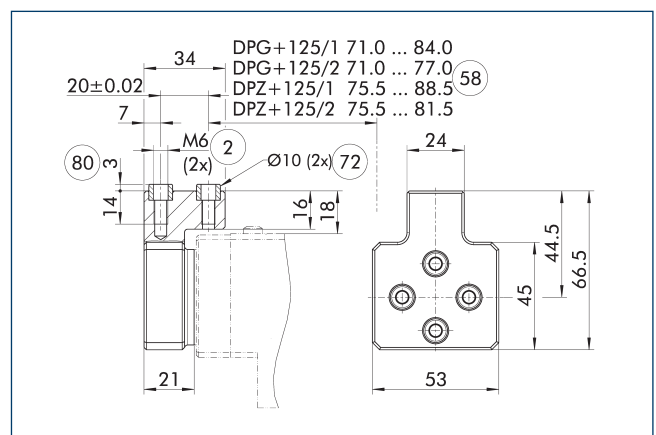

2 Finger connection

72 Fit for centering sleeves

58 Distance from center of gripper

80 Depth of the centering sleeve hole in the counter part

Optionally intermediate jaws can be used, enabling direct connection and alignment of top jaws and various standard accessories in Z-direction.

Description	ID	Material	Finger interface	Scope of delivery
Intermediate jaw				
ZBA-DPG-DPZ-plus 125-100	0300195	Aluminum	PGN-plus 100	1

DPZ-plus 125

Sealed universal gripper

Tolerance compensation unit TCU

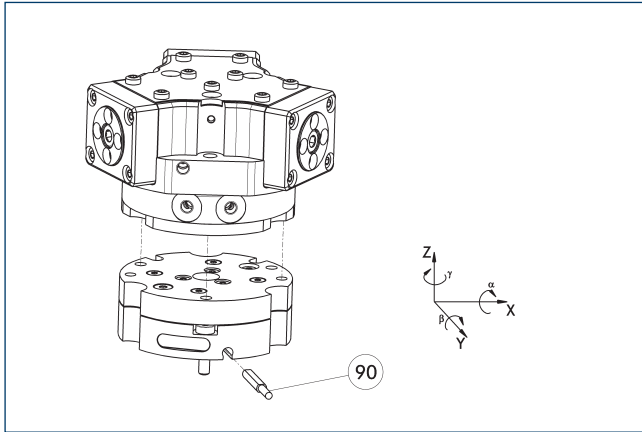

90 Monitoring of locking

Grippers can be directly mounted without an adapter plate. Tolerance compensation unit and gripper have an identical screw connection diagram. Therefore the tolerance compensation units can be assembled later. Please consider the additional assembly height of the tolerance compensation unit. For details please refer to our catalog robot accessories.

Description	ID	Locking	Deflection	Often combined
Compensation unit				
TCU-Z-125-3-MV	0324820	yes	$\pm 1^\circ/\pm 1^\circ/\pm 1^\circ$	●
TCU-Z-125-3-0V	0324821	no	$\pm 1^\circ/\pm 1^\circ/\pm 1^\circ$	

Compensation unit AGE-F

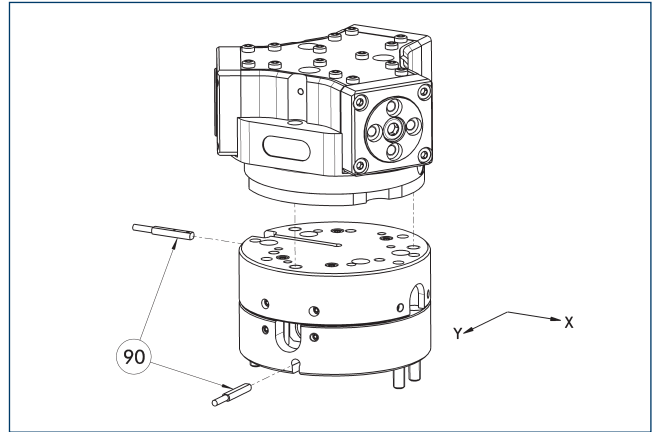

90 Monitoring

Grippers can be directly mounted without an adapter plate. For details see our catalog Gripping or Robot Accessories.

Description	ID	Compensation XY	Reset force	Often combined
		[mm]	[N]	
Compensation unit				
AGE-F-XY-080-1	0324960	± 5	39	
AGE-F-XY-080-2	0324961	± 5	85	
AGE-F-XY-080-3	0324962	± 5	90	●

Electronic magnetic switch MMS

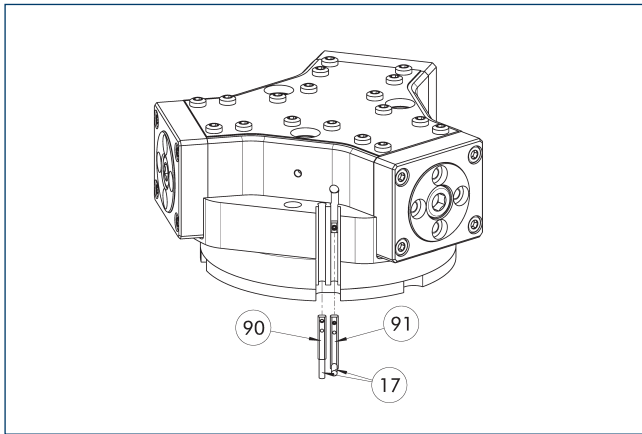

- 17 Cable outlet
- 91 Sensor MMS 22...-SA
- 90 Sensor MMS 22..

End position monitoring for mounting in the C-slot.

Description	ID	Often combined
Electronic magnetic switch		
MMS 22-S-M8-PNP	0301032	●
MMSK 22-S-PNP	0301034	
Electronic magnetic switches with lateral cable outlet		
MMS 22-S-M8-PNP-SA	0301042	●
MMSK 22-S-PNP-SA	0301044	
Reed Switches		
RMS 22-S-M8	0377720	●
Connection cables		
KA BG08-L 3P-0300-PNP	0301622	●
KA BG08-L 3P-0500-PNP	0301623	
KA BW08-L 3P-0300-PNP	0301594	
KA BW08-L 3P-0500-PNP	0301502	
clip for plug/socket		
CLI-M8	0301463	
Wireless sensor system		
RSS-T2	0377715	
RSS-T2-US/CA	0377717	
Cable extension		
KV BW08-SG08 3P-0030-PNP	0301495	
KV BW08-SG08 3P-0100-PNP	0301496	
KV BW08-SG08 3P-0200-PNP	0301497	●
Sensor distributor		
V2-M8	0301775	●
V4-M8	0301746	
V8-M8	0301751	

- ① Two sensors are required per unit for monitoring two positions. On option, extension cables and sensor distributors are available. Additional product variants of the sensor, and further information and technical data can be found in the catalog chapter sensor system.

Programmable magnetic switch MMS 22-PI1

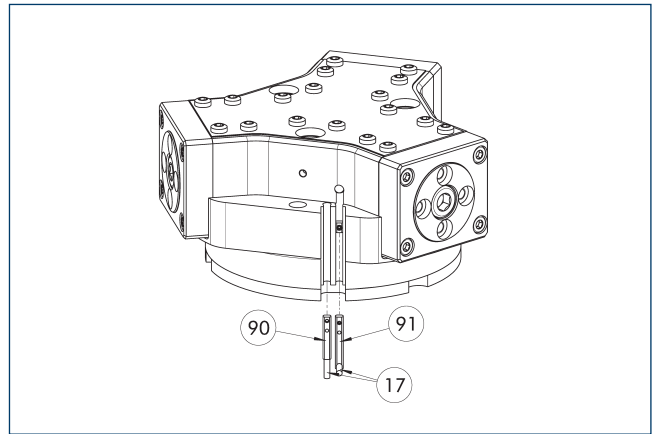

- 17 Cable outlet
- 91 Sensor MMS 22 ..-PI1...-SA
- 90 Sensor MMS 22 PI1...

Position monitoring with one programmable position per sensor and integrated electronic system in the sensor. Can be programmed using MT magnetic teaching tool (included in the scope of delivery) or ST plug teaching tool (optional). End position monitoring for mounting in the C-slot. If the ST plug teaching tools are listed in the table provided, teaching is only possible with the ST teaching tools.

Description	ID	Often combined
Programmable magnetic switch		
MMS 22-PI1-S-M8-PNP	0301160	●
MMSK 22-PI1-S-PNP	0301162	
Programmable magnetic switch with lateral cable outlet		
MMS 22-PI1-S-M8-PNP-SA	0301166	●
MMSK 22-PI1-S-PNP-SA	0301168	
Programmable magnetic switch with stainless steel housing		
MMS 22-PI1-S-M8-PNP-HD	0301110	●
MMSK 22-PI1-S-PNP-HD	0301112	

- ① Two sensors are required per unit for monitoring two positions. On option, extension cables and sensor distributors are available. Additional product variants of the sensor, and further information and technical data can be found in the catalog chapter sensor system.

DPZ-plus 125

Sealed universal gripper

Programmable magnetic switch MMS 22-PI2

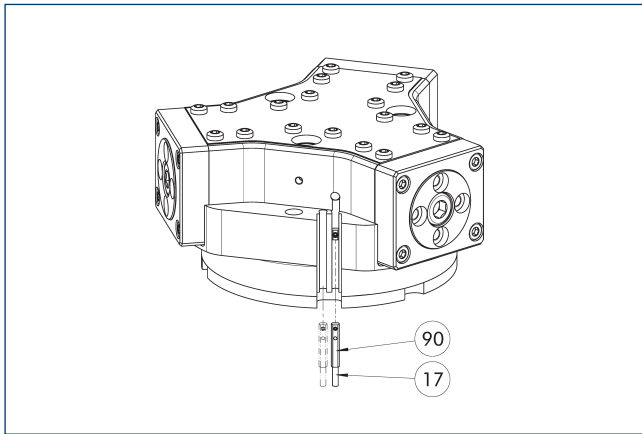

17 Cable outlet

90 MMS 22...-PI2-... sensor

Position monitoring with two programmable positions per sensor and electronics built into the sensor. Can be programmed using MT magnetic teaching tool (included in the scope of delivery) or ST plug teaching tool (optional). End position monitoring for mounting in the C-slot. If the ST plug teaching tools are listed in the table provided, teaching is only possible with the ST teaching tools.

Description	ID	Often combined
Programmable magnetic switch		
MMS 22-PI2-S-M8-PNP	0301180	●
MMSK 22-PI2-S-PNP	0301182	
Programmable magnetic switch with lateral cable outlet		
MMS 22-PI2-S-M8-PNP-SA	0301186	●
MMSK 22-PI2-S-PNP-SA	0301188	
Programmable magnetic switch with stainless steel housing		
MMS 22-PI2-S-M8-PNP-HD	0301130	●
MMSK 22-PI2-S-PNP-HD	0301132	

- ① One sensor is required per unit for monitoring two positions. Extension cables and sensor distributors are optionally available. Additional product variants of the sensor, and further information and technical data can be found in the catalog chapter sensor systems.

MMS-P programmable magnetic switch

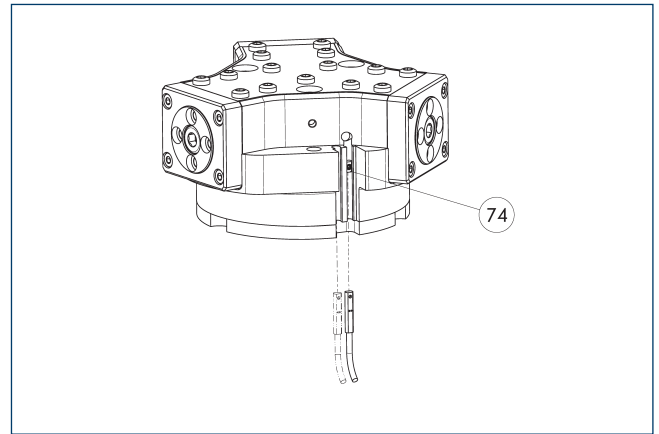

74 Limit stop for sensor

Position monitoring with two programmable positions per sensor. End position monitoring for mounting in the C-slot.

Description	ID	Often combined
Programmable magnetic switch		
MMSK-P 22-S-PNP	0301371	
MMS-P 22-S-M8-PNP	0301370	●
Connection cables		
KA BG08-L 4P-0500	0307767	●
KA BG08-L 4P-1000	0307768	
KA BW08-L 4P-0500	0307765	
KA BW08-L 4P-1000	0307766	
clip for plug/socket		
CLI-M8	0301463	
Sensor distributor		
V2-M8-4P-2XM8-3P	0301380	

- ① One sensor is required per unit for monitoring two positions. Extension cables and sensor distributors are optionally available. Additional product variants of the sensor, and further information and technical data can be found in the catalog chapter sensor systems.

Programmable magnetic switch MMS-IO-Link

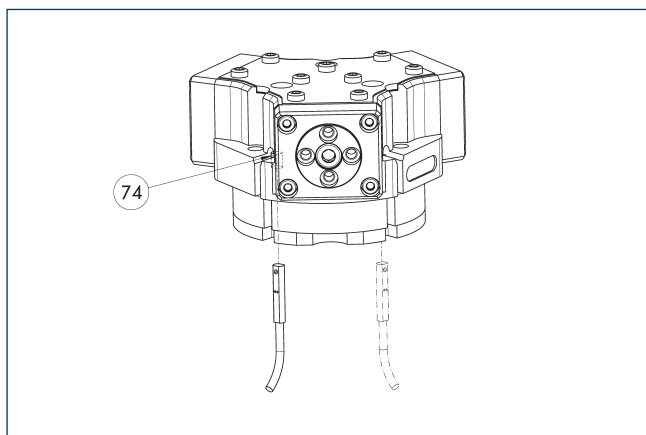

74 Limit stop for sensor

Sensor for multi-position monitoring through detection of the complete gripper stroke. The sensor is mounted directly in the C-slot of the gripper. Sensor programming on the gripper takes place via the IO-Link interface or the MT magnetic teach tool (included in scope of delivery). An IO-Link master is required for operation.

Description	ID
Programmable magnetic switch	
MMS 22-IO-L-M08	0315830
MMS 22-IO-L-M12	0315835

① One sensor is required for each gripper. No additional mounting kit is required – the gripper is equipped for use of the sensor by default. Further information and technical data can be found in the catalog chapter sensor systems.



SCHUNK GmbH & Co. KG
Spann- und Greiftechnik

Bahnhofstr. 106 - 134
D-74348 Lauffen/Neckar
Tel. +49-7133-103-0
Fax +49-7133-103-2399
info@de.schunk.com
schunk.com

Folgen Sie uns | *Follow us*

