



Superior Clamping and Gripping



Product Information

Universal gripper JGZ 125

Loadable. Reliable. Compact.

Universal gripper JGZ

Universal 3-finger centric gripper of the compact class with T-slot guidance and best cost-performance ratio

Field of application

Optimum standard solution for many fields of application. Universal application in clean and slightly dirty surroundings in machine building and plant building industry, assembly and handling as well as automotive industry.

Advantages – Your benefits

A firm focus on the essentials for maximum profitability

Sturdy T-slot guidance for the precise handling of different workpieces

Compact dimensions and low weight for minimal interfering contours in handling

High maximum moments possible suitable for using long gripper fingers

Wedge-hook design for high power transmission and synchronized gripping

Comprehensive sensor accessories for monitoring and control of the stroke position

Fastening at one gripper side in two screw directions for universal and flexible gripper assembly

Air supply via hose-free direct connection or screw connections for flexible pressure supply in all automated systems



Sizes
Quantity: 7



Weight
0.12 .. 8 kg



Gripping force
255 .. 7990 N



Stroke per jaw
2.5 .. 16 mm



Workpiece weight
1.25 .. 30 kg

Functional description

The piston is moved up and down by compressed air.
The angled active surfaces of the wedge-hook produce a synchronized, centric jaw movement.

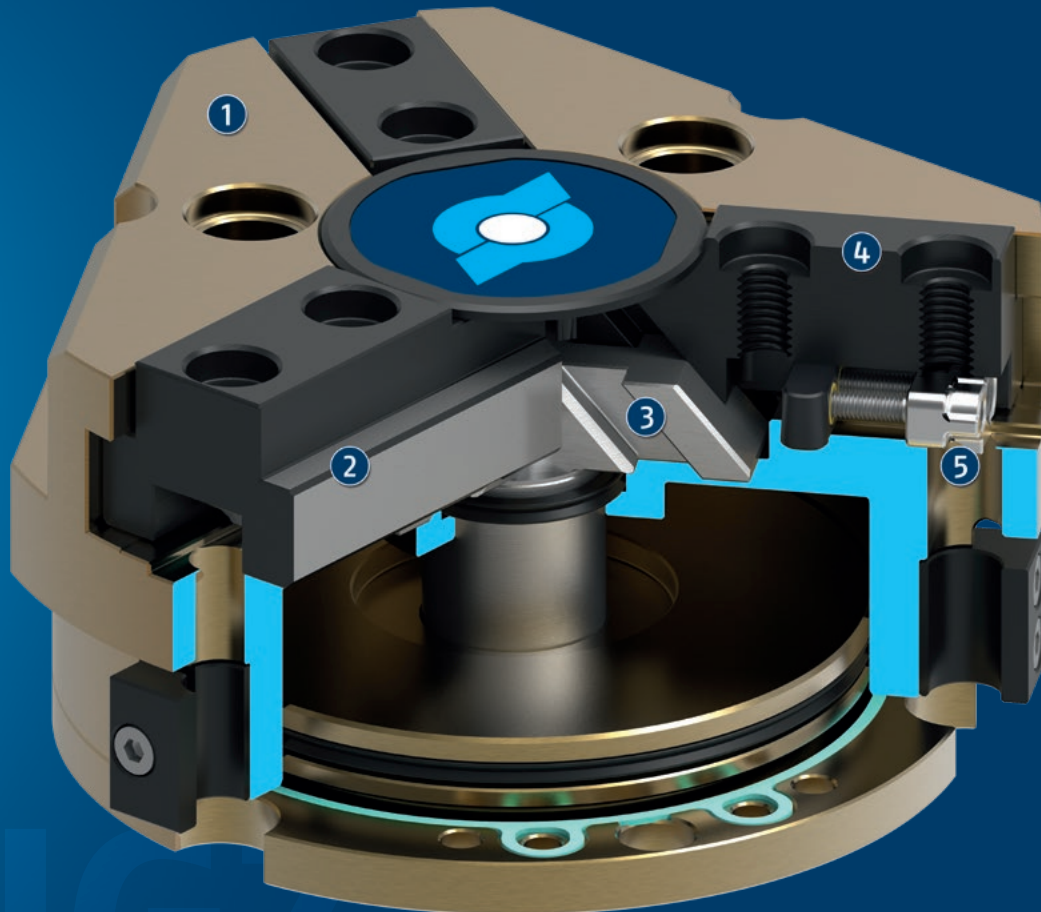

- ① **Housing**
is weight-optimized due to the use of high-strength aluminum alloy
- ② **T-slot guidance**
loadable, robust base jaw guidance for extremely long gripper fingers
- ③ **Wedge-hook design**
for high force transmission and centric gripping
- ④ **Base Jaw**
for the connection of workpiece-specific gripper fingers
- ⑤ **Sensor system**
Proximity switch can be assembled without mounting kit

General notes about the series

Operating principle: Wedge-hook kinematics

Housing material: Aluminum alloy, anodized

Base jaw material: Steel

Actuation: pneumatic, with filtered compressed air as per ISO 8573-1:2010 [7:4:4].

Warranty: 24 months

Scope of delivery: Brackets for proximity switches, centering sleeves, O-rings for direct connection, assembly instructions (operating manual with declaration of incorporation is available online)

Gripping force maintenance device: possible by using the version with mechanical gripping force maintenance or pressure maintenance valve SDV-P

Gripping force: is the arithmetic sum of the individual force applied to each jaw at distance P (see illustration).

Finger length: is measured from the reference surface as the distance P in direction to the main axis.

The maximum permissible finger length applies until the nominal operating pressure is achieved. With higher pressures, the finger length must be reduced proportionally to the nominal operating pressure.

Repeat accuracy: is defined as a distribution of the end Position for 100 consecutive strokes.

Workpiece weight: is calculated for force-fit gripping with a coefficient of static friction of 0.1 and a safety factor of 2 against workpiece slippage at acceleration due to gravity g. For form-fit or capture gripping, there are significantly higher permissible workpiece weights.

Closing and opening times: are purely the times that the base jaws or fingers are in motion. Valve switching times, hose fill times, or PLC reaction times are not included, and are to be considered when cycle times are calculated.

Application example

Tactile assembly of insertion aids in cylinder heads

- 1 3-finger centric gripper JGZ with workpiece-specific gripper fingers
- 2 Compensation unit AGE-F

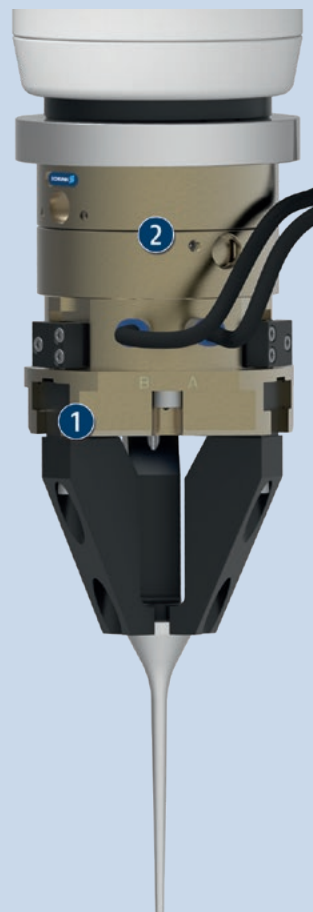

SCHUNK offers more ...

The following components make the product even more productive – the suitable addition for the highest functionality, flexibility, reliability, and controlled production.



Compensation unit

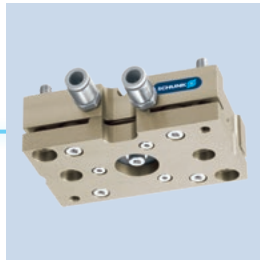

Tolerance compensation unit



Pressure maintenance valve



Universal intermediate jaw



Flexible position sensor



Analog position sensor



Finger blank



Jaw quick-change system



Magnetic switches



Inductive proximity switches

① For more information on these products can be found on the following product pages or at schunk.com.

Options and special information

Gripping force maintenance version AS/IS: The mechanical gripping force maintenance version ensures minimum gripping force even in the event of a pressure drop. In the AS/S version this acts as a closing force, in the IS version as an opening force.

The JGZ series is especially suitable for economic handling solutions and distinguishes by its high cost-benefit ratio.



Gripping force O.D. gripping

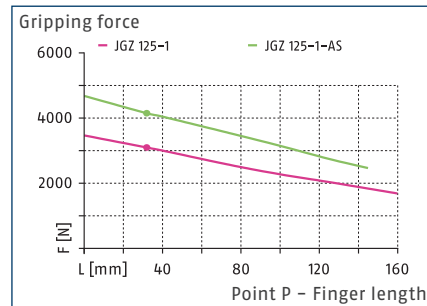

Gripping force I.D. gripping

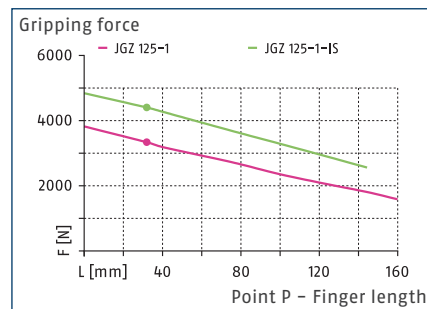

Dimensions and maximum loads

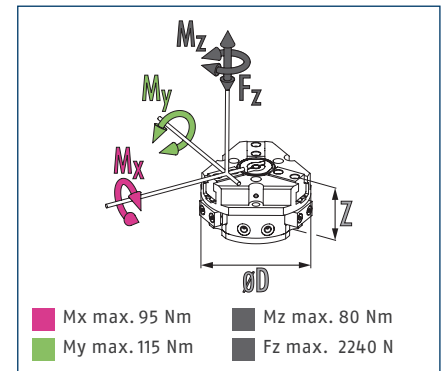

① The indicated moments and forces are static values, apply for each base jaw and may appear simultaneously. Loads may additionally occur to the moment produced by the gripping force itself.

Technical data

Description		JGZ 125-1	JGZ 125-1-AS	JGZ 125-1-IS
ID		0308950	0308951	0308952
Stroke per jaw	[mm]	13	13	13
Closing/opening force	[N]	3100/3330	4150/-	-/4400
Min. spring force	[N]		1050	1070
Weight	[kg]	2.8	3.6	3.6
Recommended workpiece weight	[kg]	15.5	15.5	15.5
Fluid consumption double stroke	[cm ³]	230	230	230
Min./nom./max. operating pressure	[bar]	2/6/8	4/6/6.5	4/6/6.5
Min./max. air purge pressure	[bar]	0.5/1	0.5/1	0.5/1
Closing/opening time	[s]	0.2/0.2	0.17/0.35	0.35/0.17
Closing/opening time with spring	[s]		0.40	0.40
Max. permissible finger length	[mm]	160	145	145
Max. permissible mass per finger	[kg]	2.1	2.1	2.1
IP protection class		40	40	40
Min./max. ambient temperature	[°C]	5/90	5/90	5/90
Repeat accuracy	[mm]	0.01	0.01	0.01
Dimensions Ø D x Z	[mm]	140 x 67	140 x 91.5	140 x 91.5

① It may take a few 100 gripping cycles until the full gripping force (as indicated in the data table) will be available.

Main view

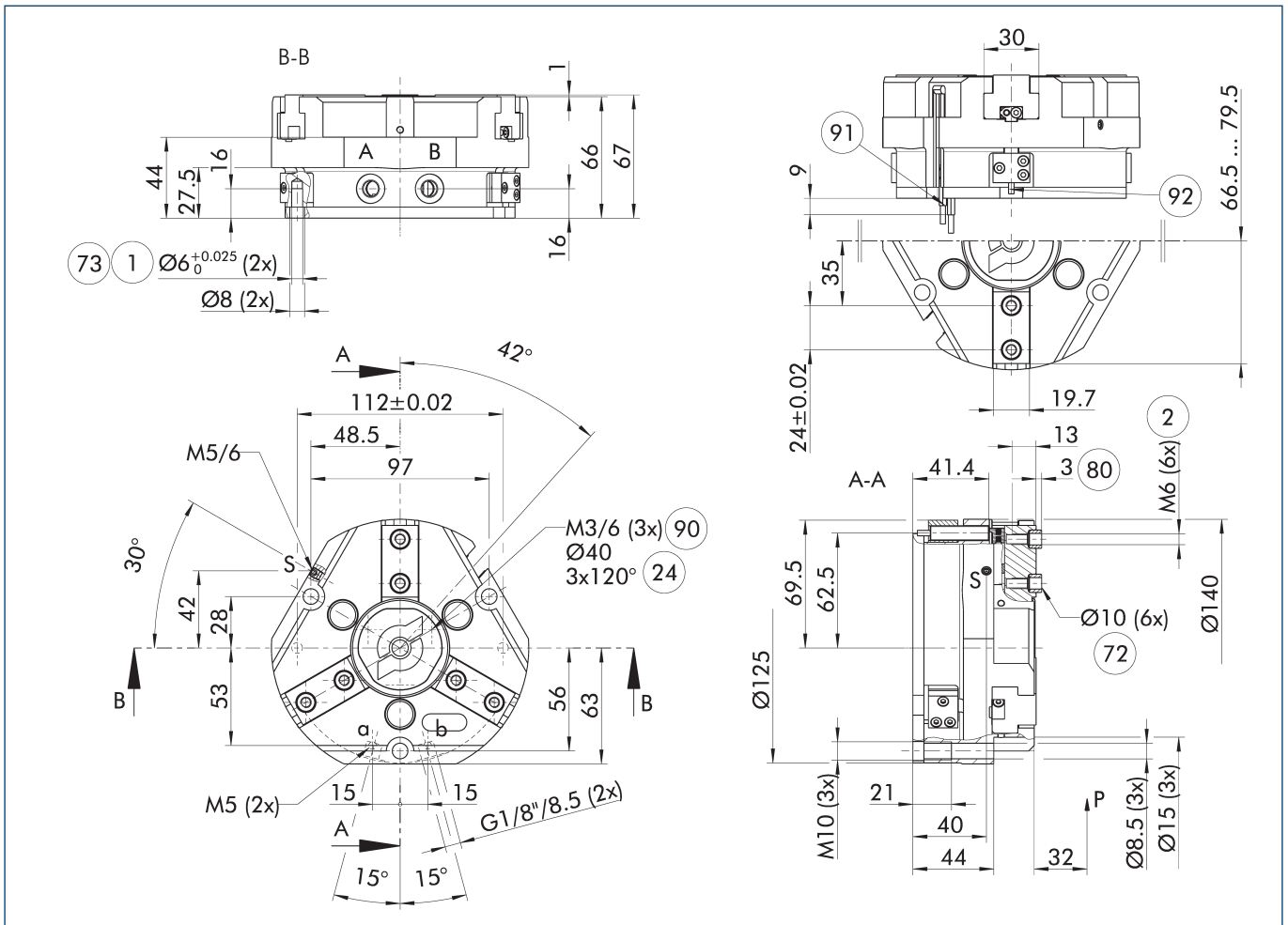

The drawing shows the gripper in the basic version with closed jaws, without dimensional consideration of the options described below.

① The SDV-P pressure maintenance valve can also be used for I.D. or O.D. gripping alternatively or in addition to the spring-loaded, mechanical gripping force maintenance device (see catalog section on accessories).

- A, a Main / direct connection, gripper opening
- B, b Main / direct connection, gripper closing
- S Air purge connection
- ① Gripper connection
- ② Finger connection
- ②④ Bolt circle
- ⑦② Fit for centering sleeves
- ⑦③ Fit for centering pins
- ⑧⑩ Depth of the centering sleeve hole in the counter part
- ⑨⑩ Thread below the cover for fastening external attachments
- ⑨① Sensor MMS 22..
- ⑨② Sensor IN ...

Hose-free direct connection M5

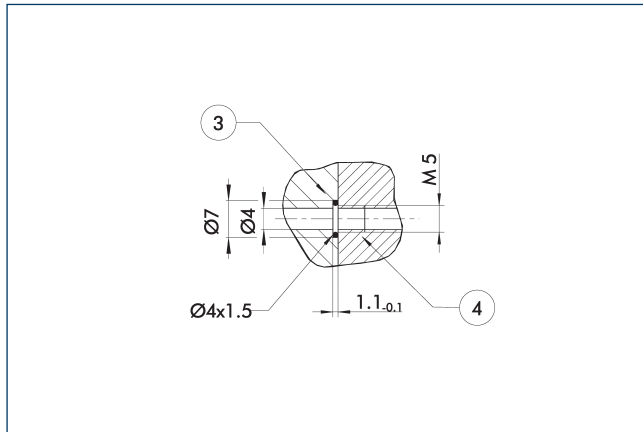

③ Adapter

④ Grippers

The direct connection is used for supplying compressed air without hoses. Instead, the pressure medium is fed through bore-holes in the mounting plate.

Gripping force maintenance device AS / IS

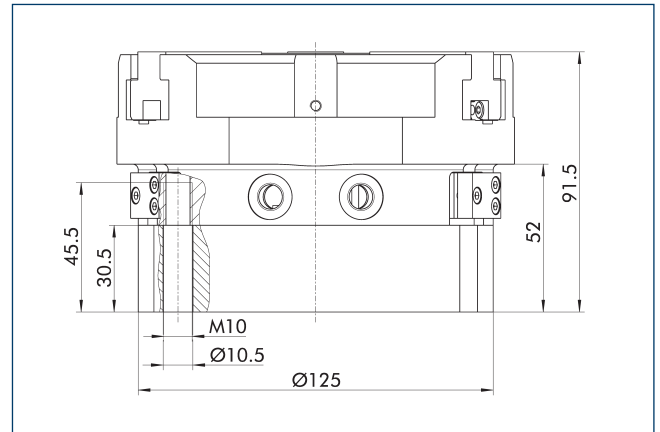

The mechanical gripping force maintenance device ensures that a minimum clamping force will be applied even if there is a drop in pressure. This acts as closing force in the AS / S version, and as opening force in the IS version. Besides this, the gripping force maintenance device can be used to increase the gripping force or for single actuated gripping.

Spring-loaded pressure piece

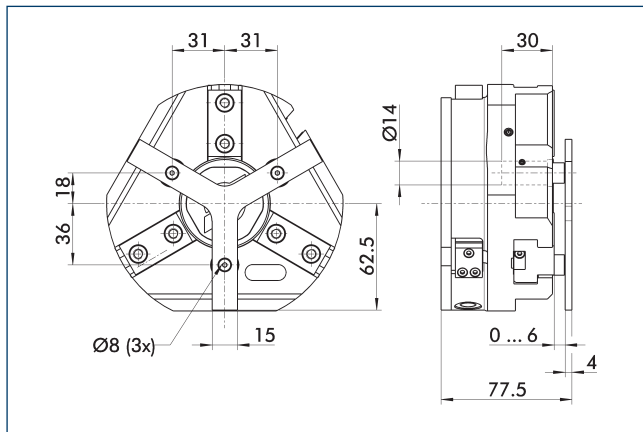

For spring-supported positioning of the workpiece against a stop after the gripper has opened. Especially developed for loading machines.

Description	ID	Stroke [mm]	Min. force [N]
Spring-loaded pressure piece			
A-PZN-plus/DPZ-plus 125	0303723	6	105

SDV-P pressure maintenance valve

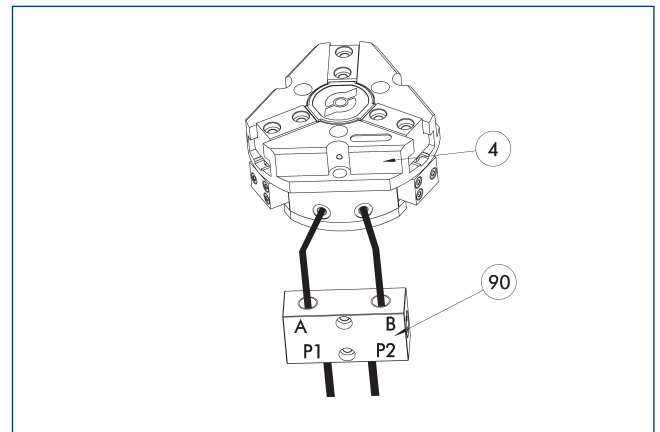

④ Grippers

⑨ SDV-P pressure maintenance valve

The SDV-P pressure maintenance valve ensures in emergency STOP situations that the pressure in the piston chamber of pneumatic gripper, swivel, linear, and quick-change modules is temporarily maintained.

Description	ID	Recommended hose diameter [mm]
Pressure maintenance valve		
SDV-P 07	0403131	8
Pressure maintenance valve with air bleed screw		
SDV-P 07-E	0300121	8

① In order to achieve the specified closing and opening time for each gripper variant, the recommended hose diameter must be used. The direct allocation of the respective variant of the gripper for the respective SDV-P can be found at schunk.com.

BSWS jaw quick-change jaw systems

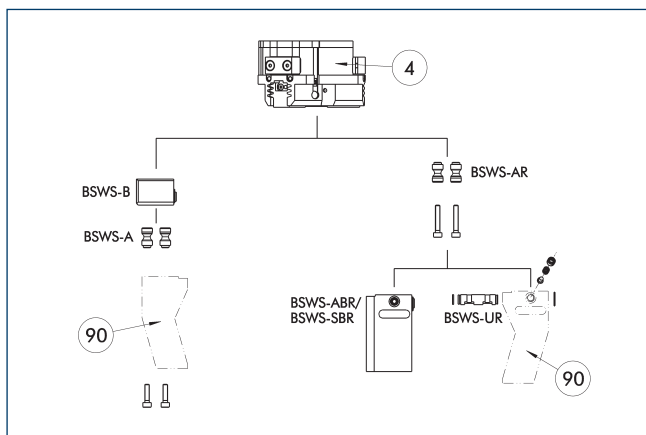

④ Grippers ⑨0 Customized gripper fingers

There are various jaw quick-change systems available for the gripper. For detailed information, please refer to the corresponding product.

Description	ID	Scope of delivery
Jaw quick-change system adapter pin		
BSWS-A 125	0303028	2
BSWS-AR 125	0300095	2
Quick-change jaw system base		
BSWS-B 125	0303029	1
Jaw quick-change system finger blank		
BSWS-ABR-PGZN-plus 125	0300075	1
BSWS-SBR-PGZN-plus 125	0300085	1
Jaw quick-change system locking mechanism		
BSWS-UR 125	0302994	1

① Only systems that are listed in the table, can be used.

Jaw quick-change system BSWS-M

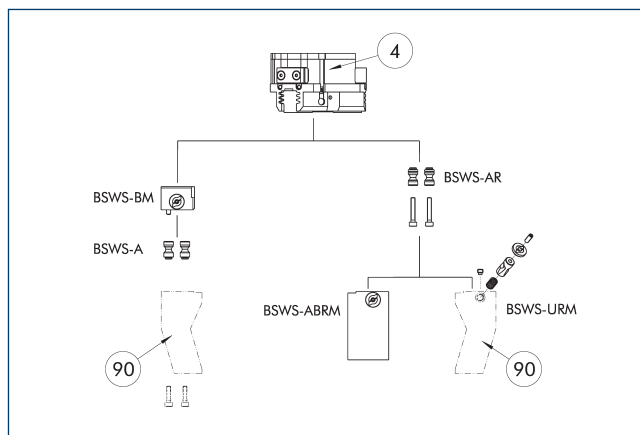

④ Grippers ⑨0 Customized gripper fingers

There are various jaw quick-change systems available for the gripper. For detailed information, please refer to the corresponding product.

Description	ID	Scope of delivery
Jaw quick-change system adapter pin		
BSWS-A 125	0303028	2
BSWS-AR 125	0300095	2
Quick-change jaw system base		
BSWS-BM 125	1302006	1
Jaw quick-change system finger blank		
BSWS-ABRM-PGZN-plus 125	1420854	1
Jaw quick-change system locking mechanism		
BSWS-URM 125	1398404	1

① Only systems that are listed in the table, can be used.

ZBA-L-plus 125 intermediate jaws

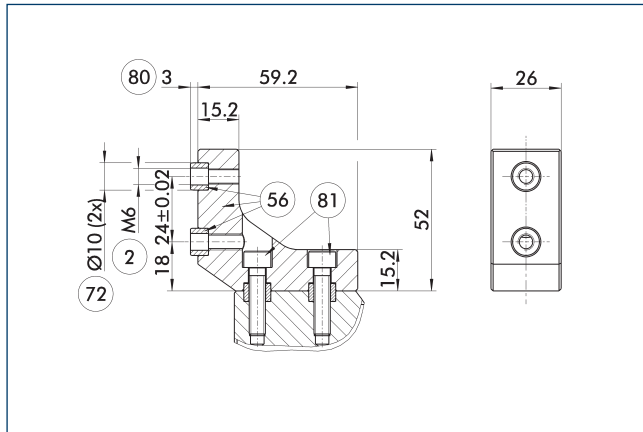

- ② Finger connection
- ⑤⑥ Included in the scope of delivery
- ⑦② Fit for centering sleeves
- ⑧⑩ Depth of the centering sleeve hole in the counter part
- ⑧① Not included in the scope of delivery

The optional ZBA-L-plus intermediate jaws allow the screw connection diagram of the top jaws to be rotated by 90°. This makes it easier to design and produce top jaws (particularly for long versions) because no deep through-bores are required.

Description	ID	Material	Finger interface	Scope of delivery
Intermediate jaw				
ZBA-L-plus 125	0311752	Aluminum	PGN-plus 125	1

UZB 125 universal intermediate jaw

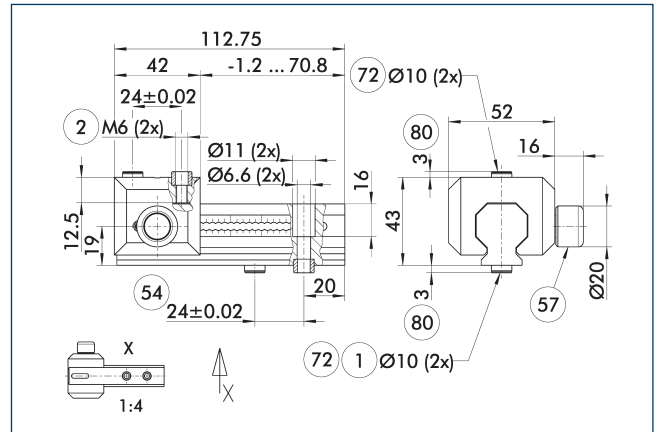

- ① Gripper connection
- ② Finger connection
- ⑤④ Optional right or left connection
- ⑤⑦ Locking
- ⑦② Fit for centering sleeves
- ⑧⑩ Depth of the centering sleeve hole in the counter part

The drawing shows the UZB universal intermediate jaw. The fully removable UZB-S slide (can also be ordered separately) allows for a quick jaw change.

Description	ID	Grid dimension
Universal intermediate jaw		
UZB 125	0300045	3
Finger blank		
ABR-PGZN-plus 125	0300013	
SBR-PGZN-plus 125	0300023	
Slide for universal intermediate jaw		
UZB-S 125	5518273	3

Finger blanks ABR- / SBR-PGZN-plus 125

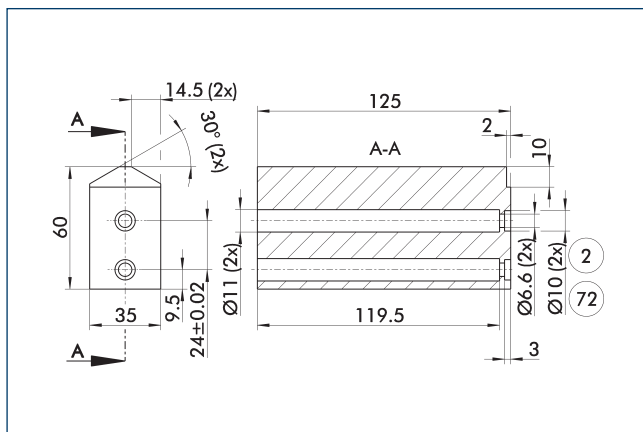

- ② Finger connection
- ⑦② Fit for centering sleeves

The drawing shows the finger blank which can be reworked by the customer.

Description	ID	Material	Scope of delivery
Finger blank			
ABR-PGZN-plus 125	0300013	Aluminum	1
SBR-PGZN-plus 125	0300023	Steel	1

Tolerance compensation unit TCU

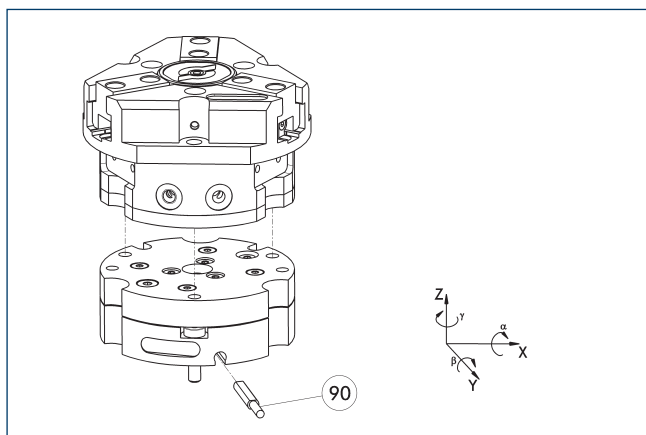

90 Monitoring of locking

Grippers can be directly mounted without an adapter plate. Tolerance compensation unit and gripper have an identical screw connection diagram. Therefore the tolerance compensation units can be assembled later. Please consider the additional assembly height of the tolerance compensation unit. For details please refer to our catalog robot accessories.

Description	ID	Locking	Deflection	Often combined
Compensation unit				
TCU-Z-125-3-MV	0324820	yes	$\pm 1^\circ/\pm 1^\circ/\pm 1^\circ$	●
TCU-Z-125-3-0V	0324821	no	$\pm 1^\circ/\pm 1^\circ/\pm 1^\circ$	

Compensation unit AGE-F

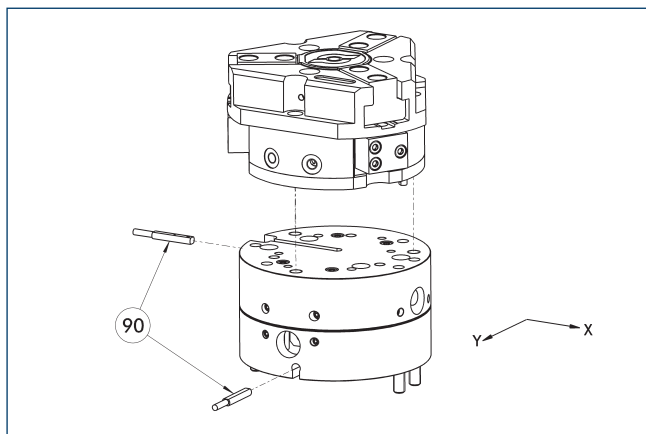

90 Monitoring

Grippers can be directly mounted without an adapter plate. For details see our catalog Gripping or Robot Accessories.

Description	ID	Compensation XY	Reset force	Often combined
		[mm]	[N]	
Compensation unit				
AGE-F-XY-080-1	0324960	± 5	39	
AGE-F-XY-080-2	0324961	± 5	85	
AGE-F-XY-080-3	0324962	± 5	90	●

Inductive Proximity Switches

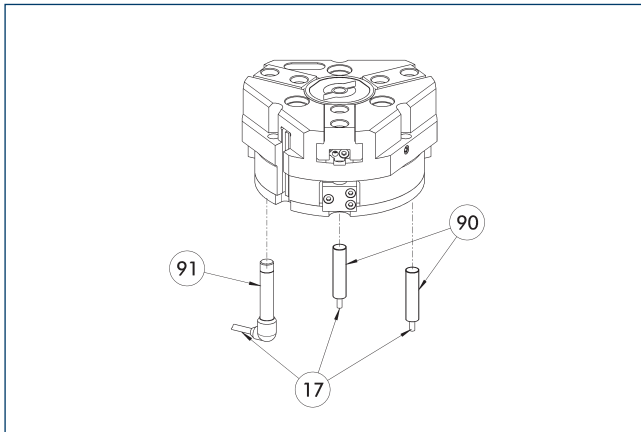

17 Cable outlet

91 Sensor IN..-SA

90 Sensor IN ...

Directly mounted end position monitoring.

Description	ID	Often combined
Inductive proximity switches		
IN 80-S-M12	0301578	
IN 80-S-M8	0301478	●
INK 80-S	0301550	
Inductive proximity switch with lateral cable outlet		
IN 80-S-M12-SA	0301587	
IN 80-S-M8-SA	0301483	●
INK 80-S-SA	0301566	
Connection cables		
KA BG08-L 3P-0300-PNP	0301622	●
KA BG08-L 3P-0500-PNP	0301623	
KA BG12-L 3P-0500-PNP	30016369	
KA BW08-L 3P-0300-PNP	0301594	
KA BW08-L 3P-0500-PNP	0301502	
KA BW12-L 3P-0300-PNP	0301503	
KA BW12-L 3P-0500-PNP	0301507	
clip for plug/socket		
CLI-M12	0301464	
CLI-M8	0301463	
Cable extension		
KV BG12-SG12 3P-0030-PNP	0301999	
KV BG12-SG12 3P-0060-PNP	0301998	
KV BW08-SG08 3P-0030-PNP	0301495	
KV BW08-SG08 3P-0100-PNP	0301496	
KV BW08-SG08 3P-0200-PNP	0301497	●
KV BW12-SG12 3P-0030-PNP	0301595	
KV BW12-SG12 3P-0100-PNP	0301596	
KV BW12-SG12 3P-0200-PNP	0301597	
Sensor distributor		
V2-M12	0301776	●
V2-M8	0301775	●
V4-M8	0301746	
V8-M8	0301751	

① Two sensors are required per unit for monitoring two positions. On option, extension cables and sensor distributors are available. Additional product variants of the sensor, and further information and technical data can be found in the catalog chapter sensor system.

Flexible position sensor

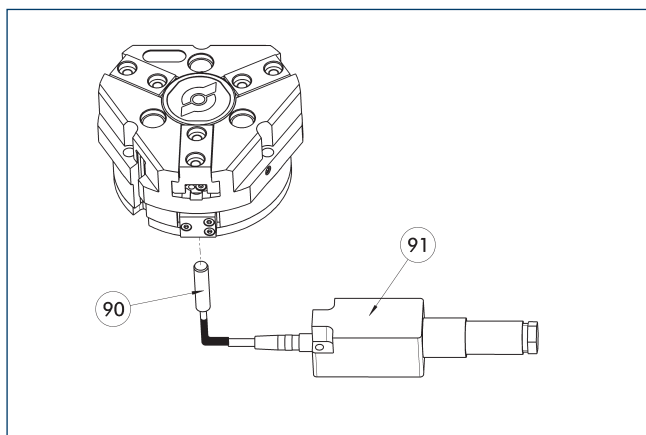

90 FPS-S sensor 91 FPS-F5 evaluation electronic

Flexible position monitoring of up to five positions.

Description	ID	
Attachment kit for FPS		
AS-FPS-PGZN-plus 125-1/PZB 160	0301636	
Sensor		
FPS-S M8	0301704	
Evaluation electronics		
FPS-F5	0301805	
Cable extension		
KV BG08-SG08 3P-0050	0301598	
KV BG08-SG08 3P-0100	0301599	

① When using an FPS system, an FPS sensor (FPS-S) as well as an electronic processor (FPS-F5 / F5 T) are required for each gripper as well as a mounting kit (AS), if listed. Cable extensions (KV) are optionally available – see catalog chapter “Accessories.”

Electronic magnetic switch MMS

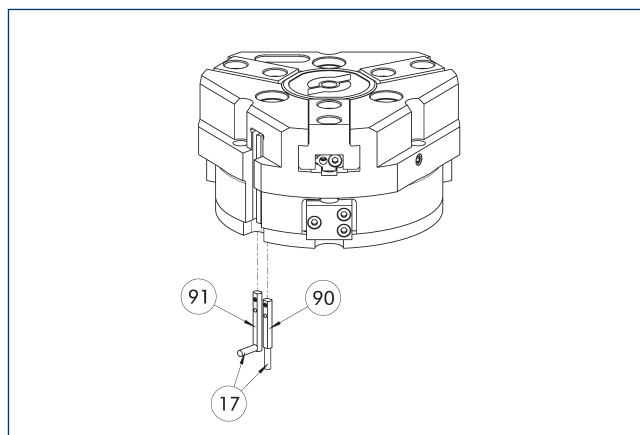

17 Cable outlet 91 Sensor MMS 22...-SA
90 Sensor MMS 22..

End position monitoring for mounting in the C-slot.

Description	ID	Often combined
Electronic magnetic switch		
MMS 22-S-M8-PNP	0301032	●
MMSK 22-S-PNP	0301034	
Electronic magnetic switches with lateral cable outlet		
MMS 22-S-M8-PNP-SA	0301042	●
MMSK 22-S-PNP-SA	0301044	
Reed Switches		
RMS 22-S-M8	0377720	●
Connection cables		
KA BG08-L 3P-0300-PNP	0301622	●
KA BG08-L 3P-0500-PNP	0301623	
KA BW08-L 3P-0300-PNP	0301594	
KA BW08-L 3P-0500-PNP	0301502	
clip for plug/socket		
CLI-M8	0301463	
Wireless sensor system		
RSS-T2	0377715	
RSS-T2-US/CA	0377717	
Cable extension		
KV BW08-SG08 3P-0030-PNP	0301495	
KV BW08-SG08 3P-0100-PNP	0301496	
KV BW08-SG08 3P-0200-PNP	0301497	●
Sensor distributor		
V2-M8	0301775	●
V4-M8	0301746	
V8-M8	0301751	

① Two sensors are required per unit for monitoring two positions. On option, extension cables and sensor distributors are available. Additional product variants of the sensor, and further information and technical data can be found in the catalog chapter sensor system.

Programmable magnetic switch MMS 22-PI1

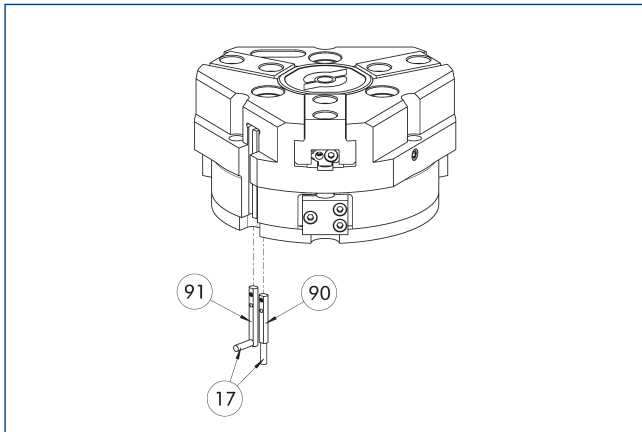

- ⑰ Cable outlet
- ① Sensor MMS 22 ..-PI1-...-SA
- ⑨ Sensor MMS 22 PI1-...

Position monitoring with one programmable position per sensor and integrated electronic system in the sensor. Can be programmed using MT magnetic teaching tool (included in the scope of delivery) or ST plug teaching tool (optional). End position monitoring for mounting in the C-slot. If the ST plug teaching tools are listed in the table provided, teaching is only possible with the ST teaching tools.

Description	ID	Often combined
Programmable magnetic switch		
MMS 22-PI1-S-M8-PNP	0301160	●
MMSK 22-PI1-S-PNP	0301162	
Programmable magnetic switch with lateral cable outlet		
MMS 22-PI1-S-M8-PNP-SA	0301166	●
MMSK 22-PI1-S-PNP-SA	0301168	
Programmable magnetic switch with stainless steel housing		
MMS 22-PI1-S-M8-PNP-HD	0301110	●
MMSK 22-PI1-S-PNP-HD	0301112	

- ① Two sensors are required per unit for monitoring two positions. On option, extension cables and sensor distributors are available. Additional product variants of the sensor, and further information and technical data can be found in the catalog chapter sensor system.

Programmable magnetic switch MMS 22-PI2

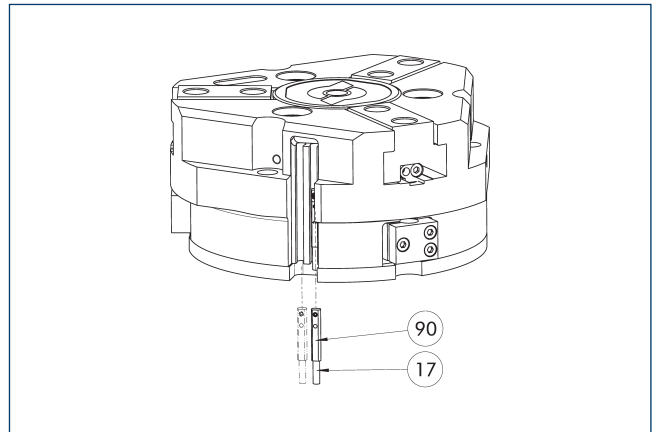

- ⑰ Cable outlet
- ⑨ MMS 22...-PI2-... sensor

Position monitoring with two programmable positions per sensor and electronics built into the sensor. Can be programmed using MT magnetic teaching tool (included in the scope of delivery) or ST plug teaching tool (optional). End position monitoring for mounting in the C-slot. If the ST plug teaching tools are listed in the table provided, teaching is only possible with the ST teaching tools.

Description	ID	Often combined
Programmable magnetic switch		
MMS 22-PI2-S-M8-PNP	0301180	●
MMSK 22-PI2-S-PNP	0301182	
Programmable magnetic switch with lateral cable outlet		
MMS 22-PI2-S-M8-PNP-SA	0301186	●
MMSK 22-PI2-S-PNP-SA	0301188	
Programmable magnetic switch with stainless steel housing		
MMS 22-PI2-S-M8-PNP-HD	0301130	●
MMSK 22-PI2-S-PNP-HD	0301132	

- ① One sensor is required per unit for monitoring two positions. Extension cables and sensor distributors are optionally available. Additional product variants of the sensor, and further information and technical data can be found in the catalog chapter sensor systems.

MMS-P programmable magnetic switch

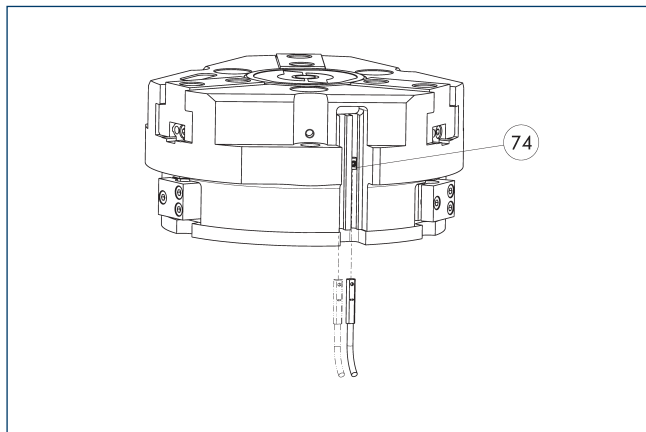

74 Limit stop for sensor

Position monitoring with two programmable positions per sensor. End position monitoring for mounting in the C-slot.

Description	ID	Often combined
Programmable magnetic switch		
MMSK-P 22-S-PNP	0301371	
MMS-P 22-S-M8-PNP	0301370	●
Connection cables		
KA GLN0804-LK-00500-A	0307767	●
KA GLN0804-LK-01000-A	0307768	
KA WLN0804-LK-00500-A	0307765	
KA WLN0804-LK-01000-A	0307766	
clip for plug/socket		
CLI-M8	0301463	
Sensor distributor		
V2-M8-4P-2XM8-3P	0301380	

① One sensor is required per unit for monitoring two positions. Extension cables and sensor distributors are optionally available. Additional product variants of the sensor, and further information and technical data can be found in the catalog chapter sensor systems.

Programmable magnetic switch MMS-IO-Link

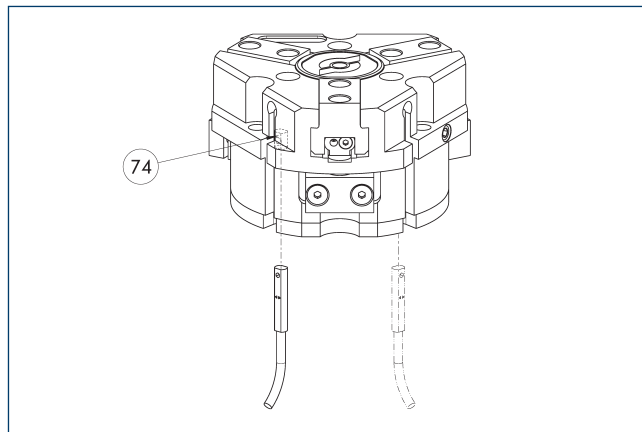

74 Limit stop for sensor

Sensor for multi-position monitoring through detection of the complete gripper stroke. The sensor is mounted directly in the C-slot of the gripper. Sensor programming on the gripper takes place via the IO-Link interface or the MT magnetic teach tool (included in scope of delivery). An IO-Link master is required for operation.

Description	ID	
Programmable magnetic switch		
MMS 22-IO-L-M08	0315830	
MMS 22-IO-L-M12	0315835	

① One sensor is required for each gripper. No additional mounting kit is required – the gripper is equipped for use of the sensor by default. Further information and technical data can be found in the catalog chapter sensor systems.

APS-Z80 analog position sensor

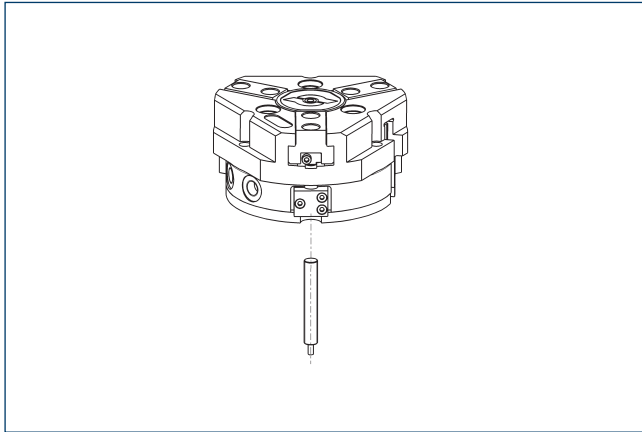

No-contact measuring, analog multi-position monitoring for any number of positions.

Description	ID	Often combined
Mounting kit for APS-Z80		
AS-APS-Z80-PGZN-plus 125-1	0302111	
Analog position sensor		
APS-Z80-K	0302072	
APS-Z80-M8	0302070	●

① When using an APS system, one mounting kit (AS-APS-Z80) and one APS-Z80 sensor is required per gripper. The resolution of the sensor can be lower in the peripheral areas of the gripper. You can find further information on the product in the operating manual.

APS-M1 analog position sensor

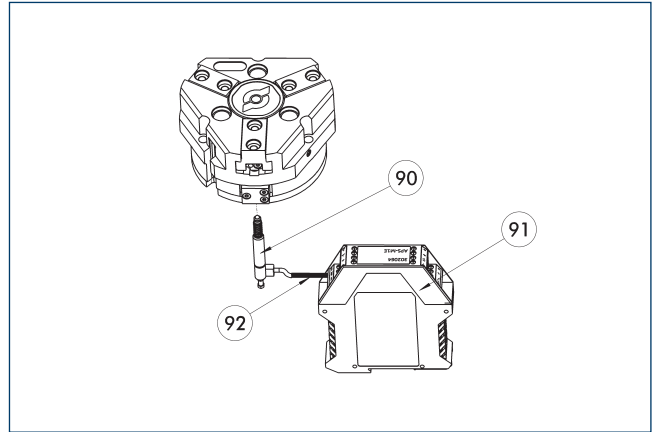

- ⑨⑩ APS-M1S sensor
- ⑨① APS-M1E electronic processor
- ⑨② APS-K extension cable

Analog multi position monitoring for any desired positions

Description	ID	
Mounting kit for APS-M1		
AS-APS-M1-PGZN-plus 125-1	0302081	
Analog position sensor		
APS-M1S	0302062	
Connection cables		
APS-K0200	0302066	
APS-K0700	0302068	
Evaluation electronics		
APS-M1E	0302064	

① When using an APS system, for each gripper an attachment kit (AS-APS-M1), an APS-M1S sensor (incl. 3 m cable) as well as an electronics (APS-M1e) are required. An extension cable (APS-K) can be connected between the sensor and the electronics as an option. The max. cable length between the sensor and the electronics is 10 m, between the electronics and their control unit (PLC) it is max. 1 m.

Cylindrical reed switches

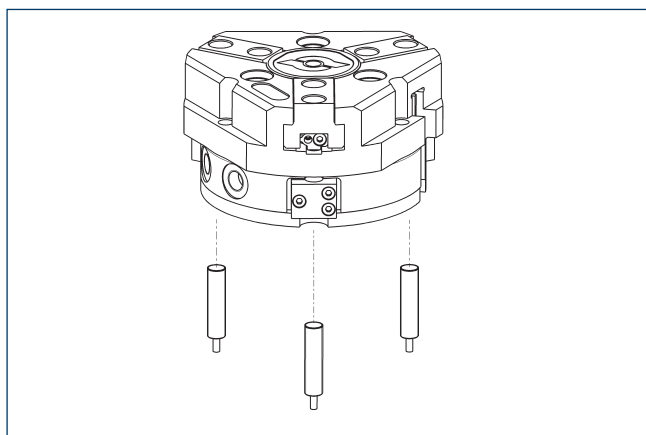

End position monitoring can be mounted with an attachment kit.

Description	ID	
Attachment kit for proximity switch		
AS-RMS 80 PGN/PZN-plus 100/125	0377726	
Reed Switches		
RMS 80-S-M8	0377721	

① Two sensors (closer/S) are required for each unit and extension cables are available as an option. This attachment kit needs to be ordered optionally as an accessory. Two mounting kits are required for each gripper. For sensor cables, note the minimum permissible bending radii. These are generally 35 mm.



SCHUNK GmbH & Co. KG
Spann- und Greiftechnik

Bahnhofstr. 106 - 134
D-74348 Lauffen/Neckar
Tel. +49-7133-103-0
Fax +49-7133-103-2399
info@de.schunk.com
schunk.com

Folgen Sie uns | *Follow us*

