



Superior Clamping and Gripping



## Product Information

Gripper for small components MPZ

# MPZ

Gripper for small components

## Precise. Compact. Reliable.

# Gripper for small components MPZ

Small 3-finger centric gripper with base jaws guided on T-slots

## Field of application

for universal use in clean to slightly dirty working environments, especially suitable for gripping small workpieces

## Advantages – Your benefits

**T-slot guidance** for precise gripping at high moment loads

**Finger position monitoring** also possible via FPS

**Air supply via hose-free direct connection or screw connections** for flexible pressure supply in all automated systems

**Compact dimensions** for minimal interfering contours in handling



Sizes  
Quantity: 6



Weight  
0.01 .. 0.29 kg



Gripping force  
20 .. 310 N



Stroke per jaw  
1 .. 5 mm



Workpiece weight  
0.05 .. 1.15 kg

## Functional description

The piston is moved up and down by compressed air.  
The angled active surfaces of the wedge-hook produce a synchronized, centric jaw movement.

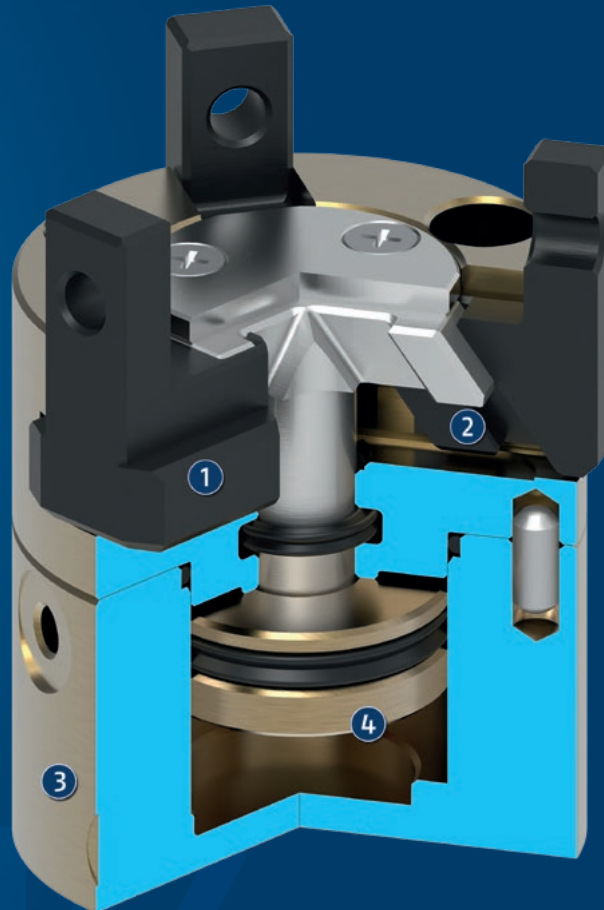

- ① **T-slot guidance**  
for precise gripping with high moment loads
- ② **Wedge-hook design**  
for high force transmission and centric gripping
- ③ **Housing**  
is weight-optimized due to the use of high-strength aluminum alloy
- ④ **Drive**  
pneumatic, efficient, and easy to handle

## General notes about the series

**Operating principle:** Wedge-hook kinematics

**Housing material:** Aluminum alloy, anodized

**Base jaw material:** Steel

**Actuation:** pneumatic, with filtered compressed air as per ISO 8573-1:2010 [7:4:4].

**Warranty:** 24 months

**Scope of delivery:** Centering sleeves, centering pins, O-rings for direct connection, assembly instructions (operating manual with declaration of incorporation is available online)

**Gripping force maintenance device:** possible by using the version with mechanical gripping force maintenance or pressure maintenance valve SDV-P

**Gripping force:** is the arithmetic sum of the individual force applied to each jaw at distance P (see illustration).

**Finger length:** is measured from the reference surface as the distance P in direction to the main axis.

The maximum permissible finger length applies until the nominal operating pressure is achieved. With higher pressures, the finger length must be reduced proportionally to the nominal operating pressure.

**Repeat accuracy:** is defined as a distribution of the end Position for 100 consecutive strokes.

**Workpiece weight:** is calculated for force-fit gripping with a coefficient of static friction of 0.1 and a safety factor of 2 against workpiece slippage at acceleration due to gravity g. For form-fit or capture gripping, there are significantly higher permissible workpiece weights.

**Closing and opening times:** are purely the times that the base jaws or fingers are in motion. Valve switching times, hose fill times, or PLC reaction times are not included, and are to be considered when cycle times are calculated.

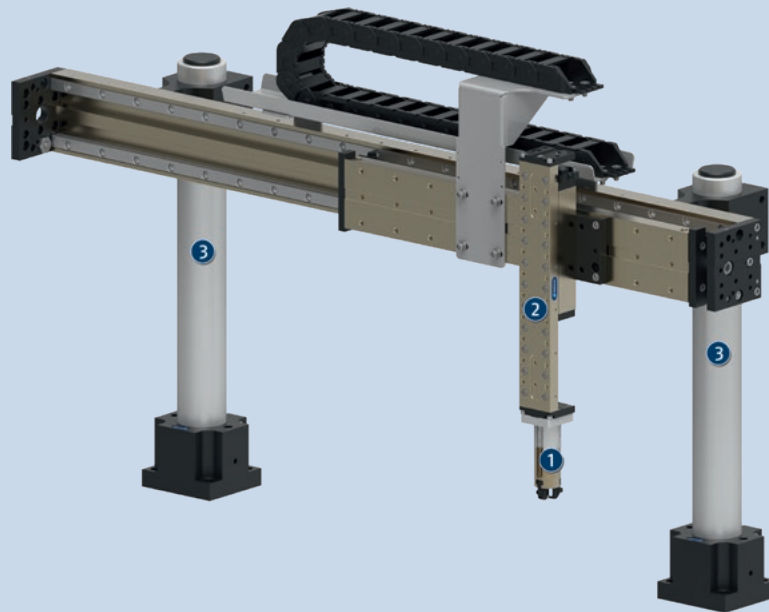

## Application example

Pneumatically driven 2-axis line gantry with centric gripper for gripping and repositioning small round workpieces.

- ① 3-finger centric gripper MPZ
- ② Linear module LM

- ③ Pillar assembly system SAS

## SCHUNK offers more ...

The following components make the product even more productive – the suitable addition for the highest functionality, flexibility, reliability, and controlled production.



Miniature swivel unit



Linear module



Pick & Place Unit



Quick change system



Flexible position sensor



Micro valve



Pressure maintenance valve



Finger blank



Magnetic switches

① For more information on these products can be found on the following product pages or at [schunk.com](http://schunk.com).

## Options and special information

**Gripping force maintenance version AS/IS:** The mechanical gripping force maintenance version ensures minimum gripping force even in the event of a pressure drop. In the AS/S version this acts as a closing force, in the IS version as an opening force.

**Version FPS for flexible position sensor:** This version is prepared for the use with the flexible position sensor FPS, and allows monitoring of several gripping positions.

**NEW: H1 grease version H1G:** with H1 compliant lubrication as a solution for easy entry into medical technology, lab automation, the pharmaceutical industry and food industry

# MPZ 16

Gripper for small components



## Gripping force O.D. gripping

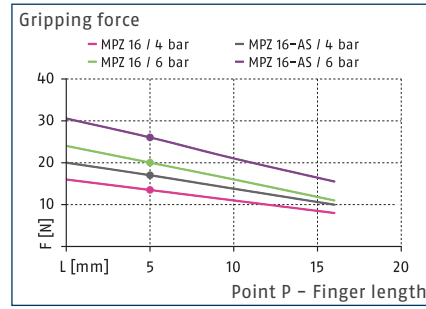

## Gripping force I.D. gripping

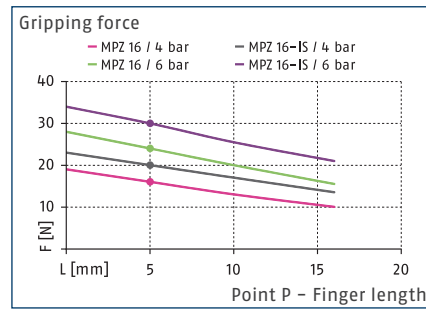

## Dimensions and maximum loads

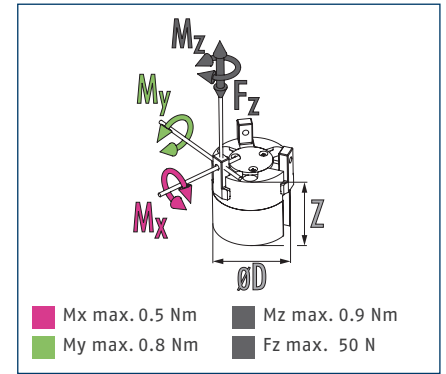

① The indicated moments and forces are static values, apply for each base jaw and may appear simultaneously. Loads may additionally occur to the moment produced by the gripping force itself.

## Technical data

Description		MPZ 16	MPZ 16-AS	MPZ 16-IS
ID		0340480	0340481	0340482
Stroke per jaw	[mm]	1	1	1
Closing/opening force	[N]	20/24	26/-	-/30
Min. spring force	[N]		6	6
Weight	[kg]	0.01	0.02	0.02
Recommended workpiece weight	[kg]	0.05	0.05	0.05
Fluid consumption double stroke	[cm <sup>3</sup> ]	0.15	0.4	0.4
Min./nom./max. operating pressure	[bar]	2/6/8	4/6/6.5	4/6/6.5
Closing/opening time	[s]	0.02/0.02	0.02/0.04	0.04/0.02
Closing/opening time with spring	[s]		0.20	0.20
Max. permissible finger length	[mm]	16	16	16
Max. permissible mass per finger	[kg]	0.02	0.02	0.02
IP protection class		40	40	40
Min./max. ambient temperature	[°C]	5/90	5/90	5/90
Repeat accuracy	[mm]	0.01	0.01	0.01
Cleanroom class ISO 14644-1:1999		5	5	5
Dimensions Ø D x Z	[mm]	16 x 20	16 x 26	16 x 26
<b>Options and their characteristics</b>				
H1 grease version		1475795	1475796	1475797

① It may take a few 100 gripping cycles until the full gripping force (as indicated in the data table) will be available.

Main view

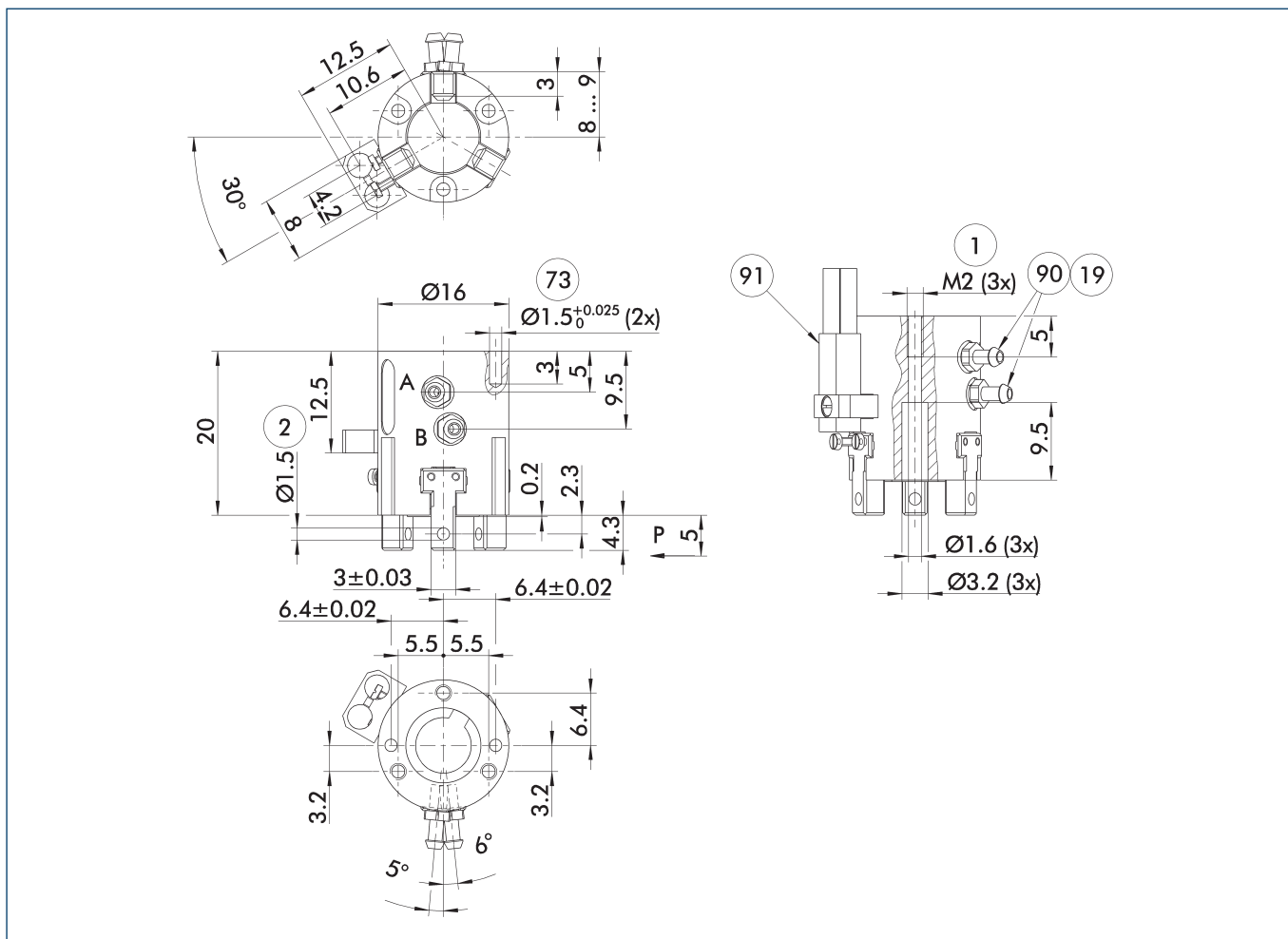

The drawing shows the gripper in the basic version with closed jaws, without dimensional consideration of the options described below.

① The SDV-P pressure maintenance valve can also be used for I.D. or O.D. gripping alternatively or in addition to the spring-loaded, mechanical gripping force maintenance device (see catalog section on accessories).

A, a Main / direct connection, gripper opening

B, b Main / direct connection, gripper closing

① Gripper connection

② Finger connection

①⑨ Air connection

⑦③ Fit for centering pins

⑨⑩ Bosch-Rexroth compressed air hose, TU1-S (Ø 3.0-0.6) series, Order no.: 1820712066 (-67/-68/-69)

⑨① Sensor IN ...

# MPZ 16

Gripper for small components

## Gripping force maintenance device AS / IS

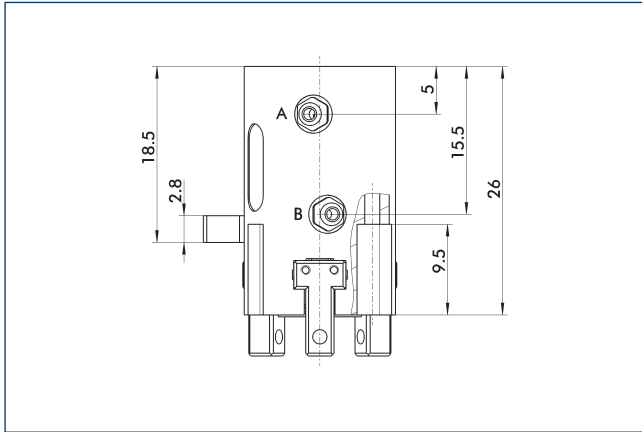

The mechanical gripping force maintenance device ensures that a minimum clamping force will be applied even if there is a drop in pressure. This acts as closing force in the AS / S version, and as opening force in the IS version. Besides this, the gripping force maintenance device can be used to increase the gripping force or for single actuated gripping.

## SDV-P pressure maintenance valve

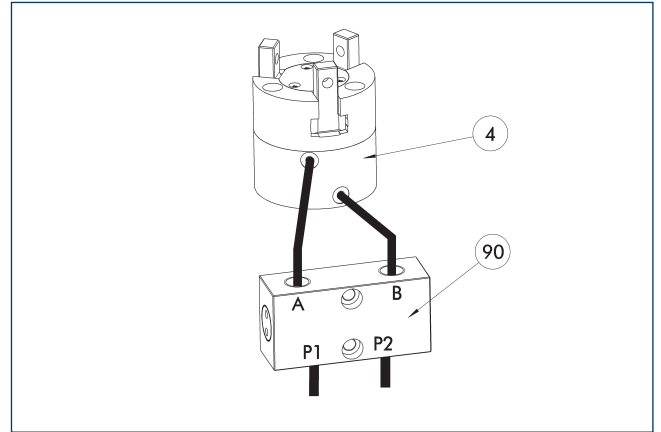

④ Grippers

⑨⑩ SDV-P pressure maintenance valve

The SDV-P pressure maintenance valve ensures in emergency STOP situations that the pressure in the piston chamber of pneumatic gripper, swivel, linear, and quick-change modules is temporarily maintained.

Description	ID	Recommended hose diameter [mm]
Pressure maintenance valve		
SDV-P 04	0403130	6
Pressure maintenance valve with air bleed screw		
SDV-P 04-E	0300120	6

① In order to achieve the specified closing and opening time for each gripper variant, the recommended hose diameter must be used. The direct allocation of the respective variant of the gripper for the respective SDV-P can be found at [schunk.com](http://schunk.com).



## Inductive Proximity Switches

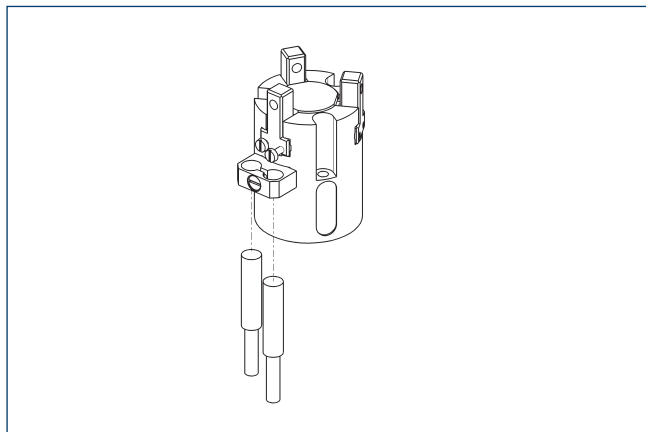

Directly mounted end position monitoring.

Description	ID	Often combined
<b>Inductive proximity switches</b>		
IN 30K-S-M8-PNP	1001272	
<b>Connection cables</b>		
KA BG08-L 3P-0300-PNP	0301622	●
KA BG08-L 3P-0500-PNP	0301623	
KA BW08-L 3P-0300-PNP	0301594	
KA BW08-L 3P-0500-PNP	0301502	
<b>clip for plug/socket</b>		
CLI-M8	0301463	
<b>Cable extension</b>		
KV BW08-SG08 3P-0030-PNP	0301495	
KV BW08-SG08 3P-0100-PNP	0301496	
KV BW08-SG08 3P-0200-PNP	0301497	●
<b>Sensor distributor</b>		
V2-M8	0301775	●
V4-M8	0301746	
V8-M8	0301751	

- ① Two sensors are required per unit for monitoring two positions. On option, extension cables and sensor distributors are available. Additional product variants of the sensor, and further information and technical data can be found in the catalog chapter sensor system.

# MPZ 20

Gripper for small components



## Gripping force O.D. gripping

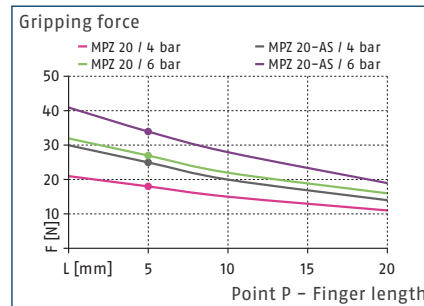

## Gripping force I.D. gripping

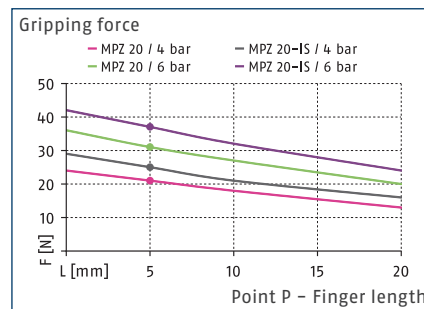

## Dimensions and maximum loads

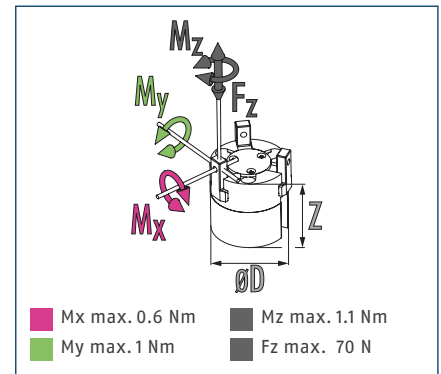

① The indicated moments and forces are static values, apply for each base jaw and may appear simultaneously. Loads may additionally occur to the moment produced by the gripping force itself.

## Technical data

Description		MPZ 20	MPZ 20-AS	MPZ 20-IS
ID		0340490	0340491	0340492
Stroke per jaw	[mm]	1.5	1.5	1.5
Closing/opening force	[N]	26/30	34/-	-/38
Min. spring force	[N]		8	8
Weight	[kg]	0.02	0.03	0.03
Recommended workpiece weight	[kg]	0.1	0.1	0.1
Fluid consumption double stroke	[cm <sup>3</sup> ]	0.3	0.7	0.7
Min./nom./max. operating pressure	[bar]	2/6/8	4/6/6.5	4/6/6.5
Closing/opening time	[s]	0.02/0.02	0.02/0.04	0.04/0.02
Closing/opening time with spring	[s]		0.20	0.20
Max. permissible finger length	[mm]	20	20	20
Max. permissible mass per finger	[kg]	0.03	0.03	0.03
IP protection class		40	40	40
Min./max. ambient temperature	[°C]	5/90	5/90	5/90
Repeat accuracy	[mm]	0.01	0.01	0.01
Cleanroom class ISO 14644-1:1999		5	5	5
Dimensions Ø D x Z	[mm]	20 x 27	20 x 33	20 x 33
<b>Options and their characteristics</b>				
H1 grease version		1475798	1475799	1475820

① It may take a few 100 gripping cycles until the full gripping force (as indicated in the data table) will be available.



## Gripping force maintenance device AS / IS

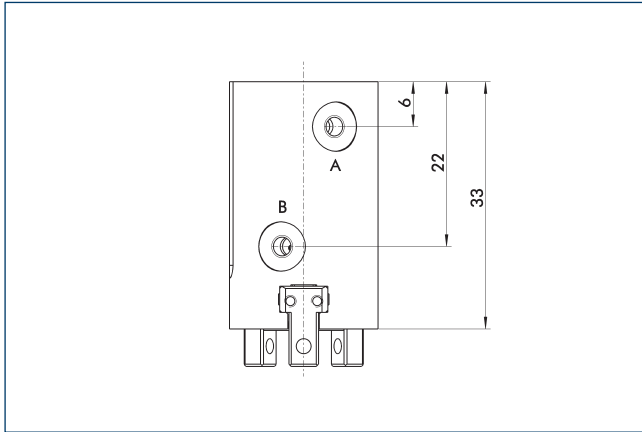

The mechanical gripping force maintenance device ensures that a minimum clamping force will be applied even if there is a drop in pressure. This acts as closing force in the AS / S version, and as opening force in the IS version. Besides this, the gripping force maintenance device can be used to increase the gripping force or for single actuated gripping.

## SDV-P pressure maintenance valve

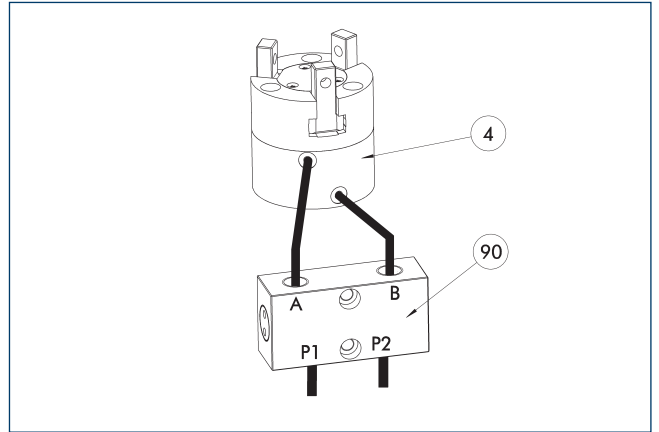

④ Grippers

⑨⑩ SDV-P pressure maintenance valve

The SDV-P pressure maintenance valve ensures in emergency STOP situations that the pressure in the piston chamber of pneumatic gripper, swivel, linear, and quick-change modules is temporarily maintained.

Description	ID	Recommended hose diameter [mm]
Pressure maintenance valve		
SDV-P 04	0403130	6
Pressure maintenance valve with air bleed screw		
SDV-P 04-E	0300120	6

① In order to achieve the specified closing and opening time for each gripper variant, the recommended hose diameter must be used. The direct allocation of the respective variant of the gripper for the respective SDV-P can be found at [schunk.com](http://schunk.com).

**Programmable magnetic switch MMS 22-PI1**

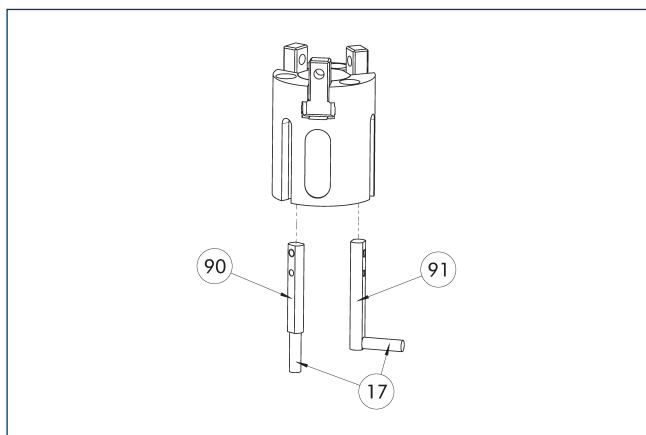

- ⑰ Cable outlet
- ① Sensor MMS 22 ..-PI1-...-SA
- ⑨ Sensor MMS 22 PI1-...

Position monitoring with one programmable position per sensor and integrated electronic system in the sensor. Can be programmed using MT magnetic teaching tool (included in the scope of delivery) or ST plug teaching tool (optional). End position monitoring for mounting in the C-slot. If the ST plug teaching tools are listed in the table provided, teaching is only possible with the ST teaching tools.

Description	ID	Often combined
<b>Programmable magnetic switch</b>		
MMS 22-PI1-S-M8-PNP	0301160	●
MMSK 22-PI1-S-PNP	0301162	
<b>Programmable magnetic switch with lateral cable outlet</b>		
MMS 22-PI1-S-M8-PNP-SA	0301166	●
MMSK 22-PI1-S-PNP-SA	0301168	
<b>Programmable magnetic switch with stainless steel housing</b>		
MMS 22-PI1-S-M8-PNP-HD	0301110	●
MMSK 22-PI1-S-PNP-HD	0301112	

① Two sensors are required per unit for monitoring two positions. On option, extension cables and sensor distributors are available. Additional product variants of the sensor, and further information and technical data can be found in the catalog chapter sensor system.

**Programmable magnetic switch MMS 22-PI2**

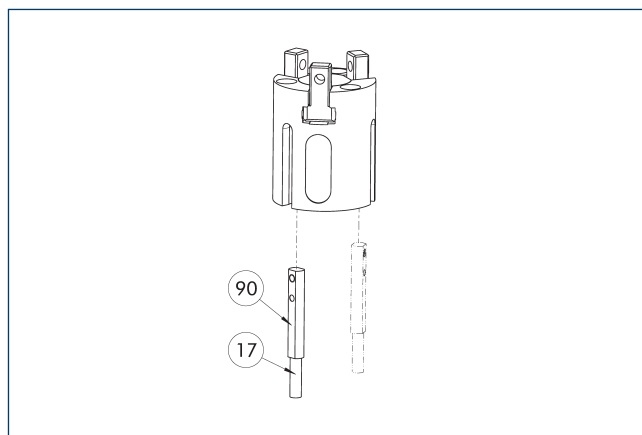

- ⑰ Cable outlet
- ⑨ MMS 22...-PI2-... sensor

Position monitoring with two programmable positions per sensor and electronics built into the sensor. Can be programmed using MT magnetic teaching tool (included in the scope of delivery) or ST plug teaching tool (optional). End position monitoring for mounting in the C-slot. If the ST plug teaching tools are listed in the table provided, teaching is only possible with the ST teaching tools.

Description	ID	Often combined
<b>Programmable magnetic switch</b>		
MMS 22-PI2-S-M8-PNP	0301180	●
MMSK 22-PI2-S-PNP	0301182	
<b>Programmable magnetic switch with lateral cable outlet</b>		
MMS 22-PI2-S-M8-PNP-SA	0301186	●
MMSK 22-PI2-S-PNP-SA	0301188	
<b>Programmable magnetic switch with stainless steel housing</b>		
MMS 22-PI2-S-M8-PNP-HD	0301130	●
MMSK 22-PI2-S-PNP-HD	0301132	

① One sensor is required per unit for monitoring two positions. Extension cables and sensor distributors are optionally available. Additional product variants of the sensor, and further information and technical data can be found in the catalog chapter sensor systems.

## MMS-P programmable magnetic switch

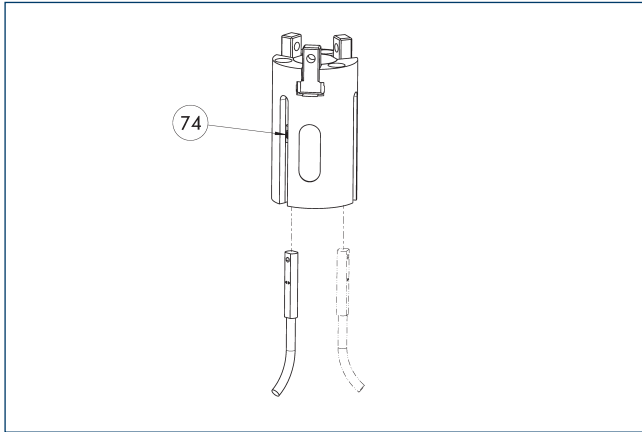

74 Limit stop for sensor

Position monitoring with two programmable positions per sensor. End position monitoring for mounting in the C-slot.

Description	ID	Often combined
Programmable magnetic switch		
MMSK-P 22-S-PNP	0301371	
MMS-P 22-S-M8-PNP	0301370	●
Connection cables		
KA GLN0804-LK-00500-A	0307767	●
KA GLN0804-LK-01000-A	0307768	
KA WLN0804-LK-00500-A	0307765	
KA WLN0804-LK-01000-A	0307766	
clip for plug/socket		
CLI-M8	0301463	
Sensor distributor		
V2-M8-4P-2XM8-3P	0301380	

① One sensor is required per unit for monitoring two positions. Extension cables and sensor distributors are optionally available. Additional product variants of the sensor, and further information and technical data can be found in the catalog chapter sensor systems.



# MPZ 25

Gripper for small components



## Gripping force O.D. gripping

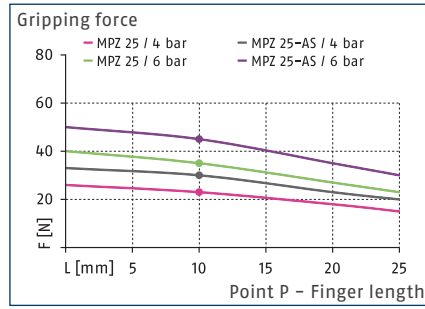

## Gripping force I.D. gripping

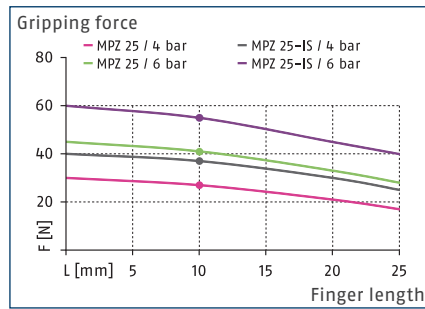

## Dimensions and maximum loads

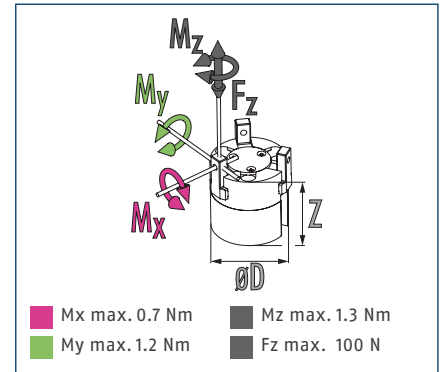

① The indicated moments and forces are static values, apply for each base jaw and may appear simultaneously. Loads may additionally occur to the moment produced by the gripping force itself.

## Technical data

Description		MPZ 25	MPZ 25-AS	MPZ 25-IS
ID		0340500	0340501	0340502
Stroke per jaw	[mm]	2	2	2
Closing/opening force	[N]	35/40	47/-	-/55
Min. spring force	[N]		12	15
Weight	[kg]	0.04	0.06	0.06
Recommended workpiece weight	[kg]	0.2	0.2	0.2
Fluid consumption double stroke	[cm <sup>3</sup> ]	0.6	1.8	1.8
Min./nom./max. operating pressure	[bar]	2/6/8	4/6/6.5	4/6/6.5
Closing/opening time	[s]	0.02/0.02	0.02/0.04	0.04/0.02
Closing/opening time with spring	[s]		0.20	0.20
Max. permissible finger length	[mm]	25	25	25
Max. permissible mass per finger	[kg]	0.03	0.03	0.03
IP protection class		40	40	40
Min./max. ambient temperature	[°C]	5/90	5/90	5/90
Repeat accuracy	[mm]	0.01	0.01	0.01
Cleanroom class ISO 14644-1:1999		5	5	5
Dimensions Ø D x Z	[mm]	25 x 30	25 x 42	25 x 42
<b>Options and their characteristics</b>				
H1 grease version		1377410	1314605	1475821

① It may take a few 100 gripping cycles until the full gripping force (as indicated in the data table) will be available.



Main view

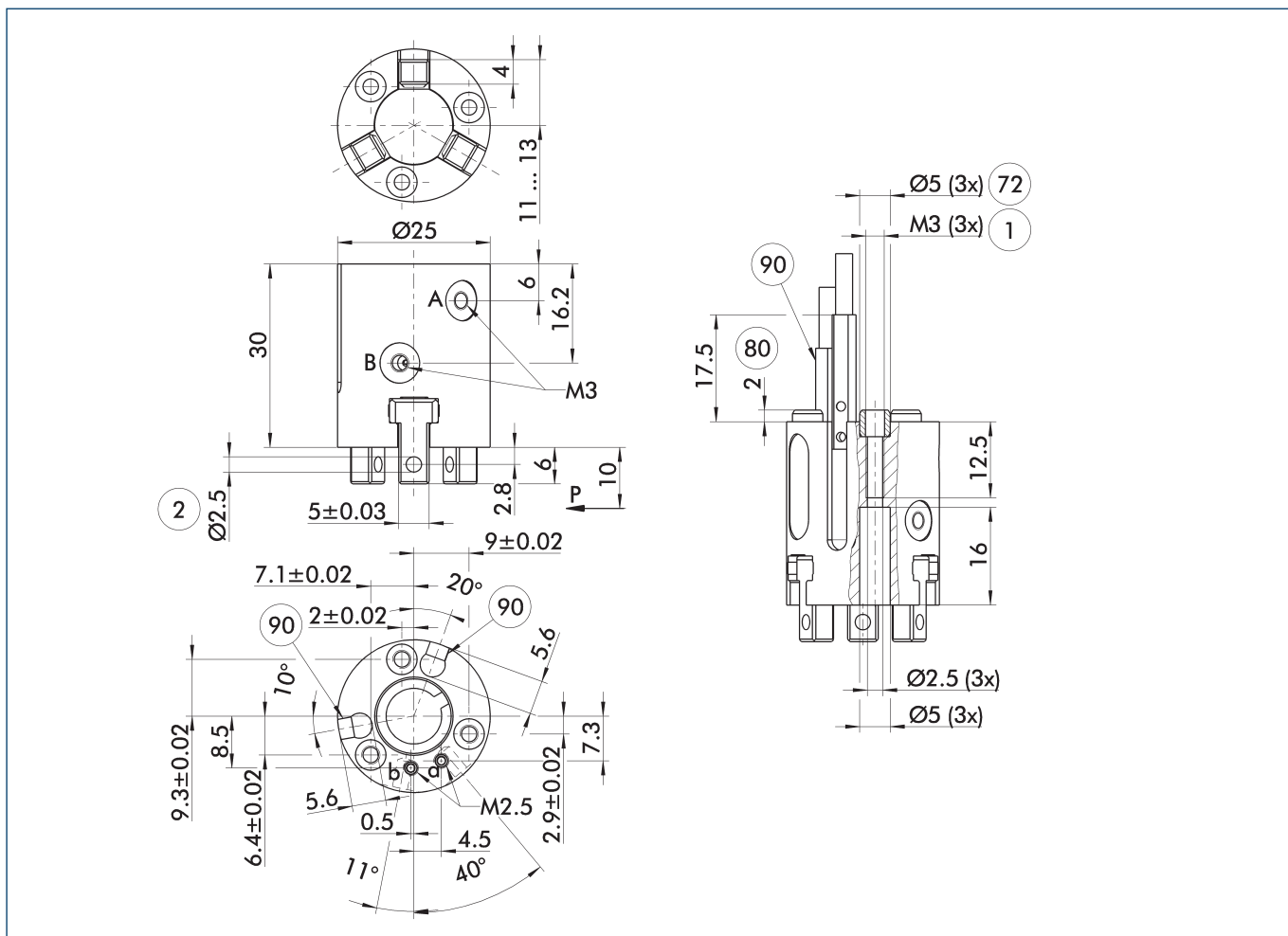

The drawing shows the gripper in the basic version with closed jaws, without dimensional consideration of the options described below.

① The SDV-P pressure maintenance valve can also be used for I.D. or O.D. gripping alternatively or in addition to the spring-loaded, mechanical gripping force maintenance device (see catalog section on accessories).

- A, a Main / direct connection, gripper opening
- B, b Main / direct connection, gripper closing
- ① Gripper connection

- ② Finger connection
- 72 Fit for centering sleeves
- 80 Depth of the centering sleeve hole in the counter part
- 90 Sensor MMS 22..

# MPZ 25

Gripper for small components

## Hose-free direct connection M2.5

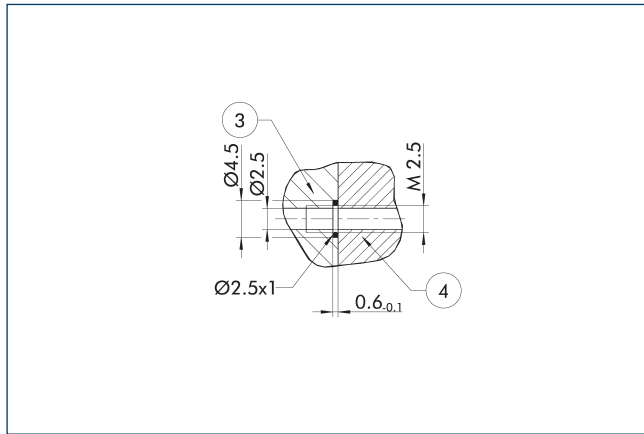

- ③ Adapter
- ④ Grippers

The direct connection is used for supplying compressed air without hoses. Instead, the pressure medium is fed through bore-holes in the mounting plate.

## Gripping force maintenance device AS / IS

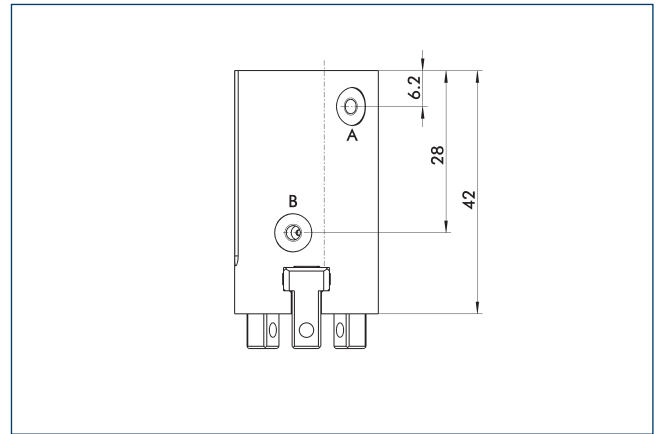

The mechanical gripping force maintenance device ensures that a minimum clamping force will be applied even if there is a drop in pressure. This acts as closing force in the AS / S version, and as opening force in the IS version. Besides this, the gripping force maintenance device can be used to increase the gripping force or for single actuated gripping.

## SDV-P pressure maintenance valve

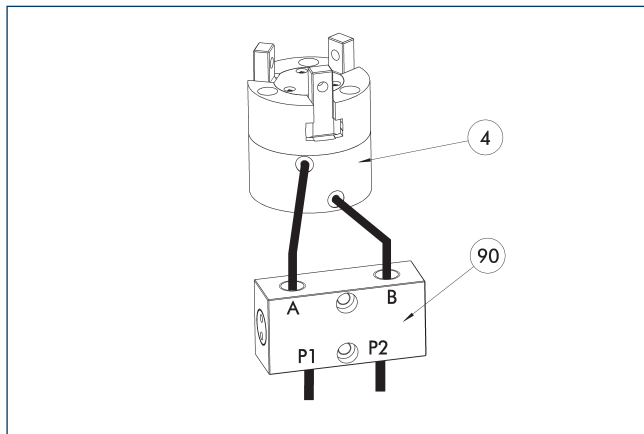

- ④ Grippers
- ⑨⑩ SDV-P pressure maintenance valve

The SDV-P pressure maintenance valve ensures in emergency STOP situations that the pressure in the piston chamber of pneumatic gripper, swivel, linear, and quick-change modules is temporarily maintained.

Description	ID	Recommended hose diameter [mm]
Pressure maintenance valve		
SDV-P 04	0403130	6
Pressure maintenance valve with air bleed screw		
SDV-P 04-E	0300120	6

① In order to achieve the specified closing and opening time for each gripper variant, the recommended hose diameter must be used. The direct allocation of the respective variant of the gripper for the respective SDV-P can be found at schunk.com.

## Programmable magnetic switch MMS 22-PI1

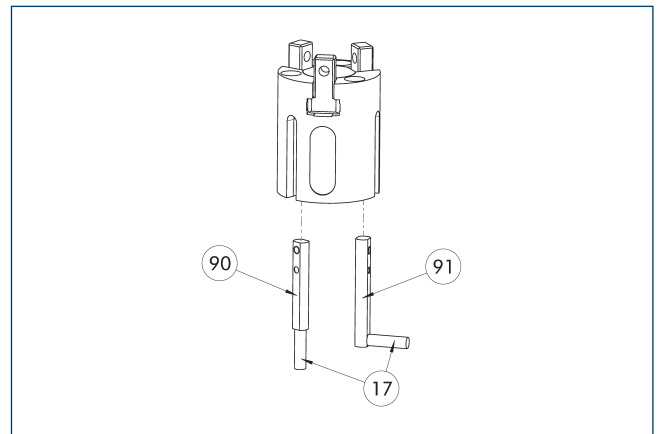

- ①⑦ Cable outlet
- ⑨⑩ Sensor MMS 22 PI1-...
- ⑨① Sensor MMS 22 ...-PI1-...-SA

Position monitoring with one programmable position per sensor and integrated electronic system in the sensor. Can be programmed using MT magnetic teaching tool (included in the scope of delivery) or ST plug teaching tool (optional). End position monitoring for mounting in the C-slot. If the ST plug teaching tools are listed in the table provided, teaching is only possible with the ST teaching tools.

Description	ID	Often combined
Programmable magnetic switch		
MMS 22-PI1-S-M8-PNP	0301160	●
MMSK 22-PI1-S-PNP	0301162	
Programmable magnetic switch with lateral cable outlet		
MMS 22-PI1-S-M8-PNP-SA	0301166	●
MMSK 22-PI1-S-PNP-SA	0301168	
Programmable magnetic switch with stainless steel housing		
MMS 22-PI1-S-M8-PNP-HD	0301110	●
MMSK 22-PI1-S-PNP-HD	0301112	

① Two sensors are required per unit for monitoring two positions. On option, extension cables and sensor distributors are available. Additional product variants of the sensor, and further information and technical data can be found in the catalog chapter sensor system.

**Programmable magnetic switch MMS 22-PI2**

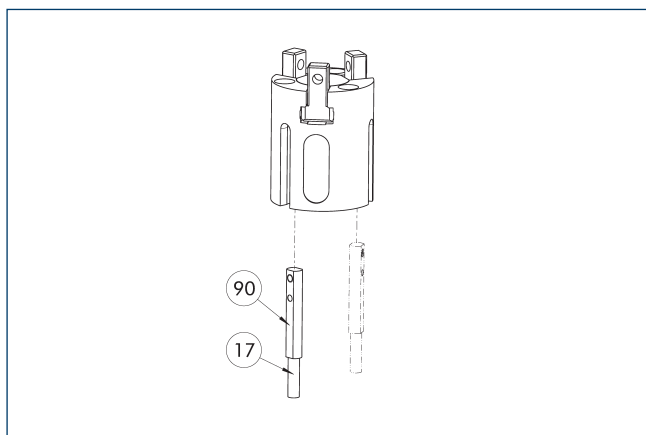

⑰ Cable outlet                      ⑨① MMS 22...-PI2-... sensor

Position monitoring with two programmable positions per sensor and electronics built into the sensor. Can be programmed using MT magnetic teaching tool (included in the scope of delivery) or ST plug teaching tool (optional). End position monitoring for mounting in the C-slot. If the ST plug teaching tools are listed in the table provided, teaching is only possible with the ST teaching tools.

Description	ID	Often combined
<b>Programmable magnetic switch</b>		
MMS 22-PI2-S-M8-PNP	0301180	●
MMSK 22-PI2-S-PNP	0301182	
<b>Programmable magnetic switch with lateral cable outlet</b>		
MMS 22-PI2-S-M8-PNP-SA	0301186	●
MMSK 22-PI2-S-PNP-SA	0301188	
<b>Programmable magnetic switch with stainless steel housing</b>		
MMS 22-PI2-S-M8-PNP-HD	0301130	●
MMSK 22-PI2-S-PNP-HD	0301132	

① One sensor is required per unit for monitoring two positions. Extension cables and sensor distributors are optionally available. Additional product variants of the sensor, and further information and technical data can be found in the catalog chapter sensor systems.

**MMS-P programmable magnetic switch**

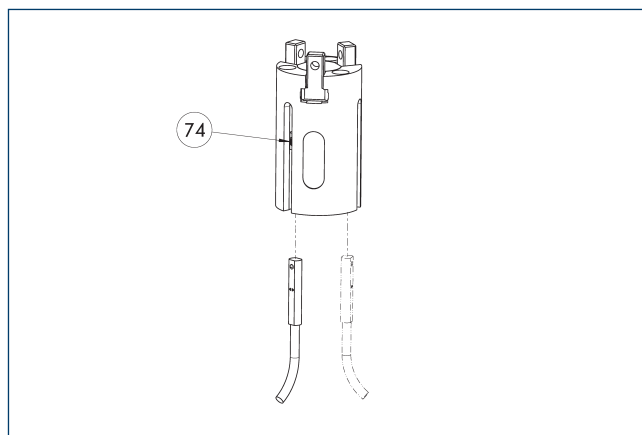

⑦④ Limit stop for sensor

Position monitoring with two programmable positions per sensor. End position monitoring for mounting in the C-slot.

Description	ID	Often combined
<b>Programmable magnetic switch</b>		
MMSK-P 22-S-PNP	0301371	
MMS-P 22-S-M8-PNP	0301370	●
<b>Connection cables</b>		
KA GLN0804-LK-00500-A	0307767	●
KA GLN0804-LK-01000-A	0307768	
KA WLN0804-LK-00500-A	0307765	
KA WLN0804-LK-01000-A	0307766	
<b>clip for plug/socket</b>		
CLI-M8	0301463	
<b>Sensor distributor</b>		
V2-M8-4P-2XM8-3P	0301380	

① One sensor is required per unit for monitoring two positions. Extension cables and sensor distributors are optionally available. Additional product variants of the sensor, and further information and technical data can be found in the catalog chapter sensor systems.

# MPZ 30

Gripper for small components



## Gripping force O.D. gripping

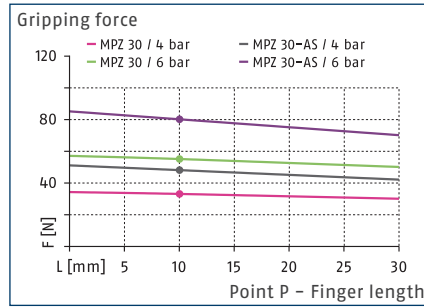

## Gripping force I.D. gripping

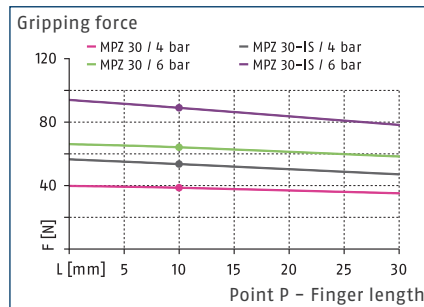

## Dimensions and maximum loads

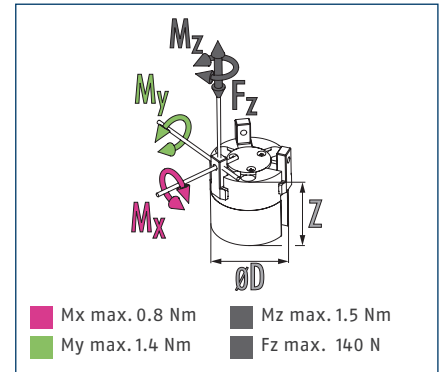

① The indicated moments and forces are static values, apply for each base jaw and may appear simultaneously. Loads may additionally occur to the moment produced by the gripping force itself.

## Technical data

Description		MPZ 30	MPZ 30-FPS	MPZ 30-AS	MPZ 30-IS
ID		0340510	0340513	0340511	0340512
Stroke per jaw	[mm]	3	3	3	3
Closing/opening force	[N]	55/65	55/65	80/-	-/90
Min. spring force	[N]			25	25
Weight	[kg]	0.08	0.1	0.09	0.09
Recommended workpiece weight	[kg]	0.28	0.28	0.28	0.28
Fluid consumption double stroke	[cm <sup>3</sup> ]	1.8	1.8	4.2	3.2
Min./nom./max. operating pressure	[bar]	2/6/8	2/6/8	4/6/6.5	4/6/6.5
Closing/opening time	[s]	0.02/0.02	0.02/0.02	0.02/0.04	0.04/0.02
Closing/opening time with spring	[s]			0.30	0.30
Max. permissible finger length	[mm]	30	30	30	30
Max. permissible mass per finger	[kg]	0.03	0.03	0.03	0.03
IP protection class		40	40	40	40
Min./max. ambient temperature	[°C]	5/90	5/90	5/90	5/90
Repeat accuracy	[mm]	0.01	0.01	0.01	0.01
Cleanroom class ISO 14644-1:1999		5	5	5	5
Dimensions Ø D x Z	[mm]	30 x 32	30 x 46	30 x 45	30 x 45
<b>Options and their characteristics</b>					
H1 grease version		30028778	1475822	30075342	30041802

① It may take a few 100 gripping cycles until the full gripping force (as indicated in the data table) will be available.

Main view

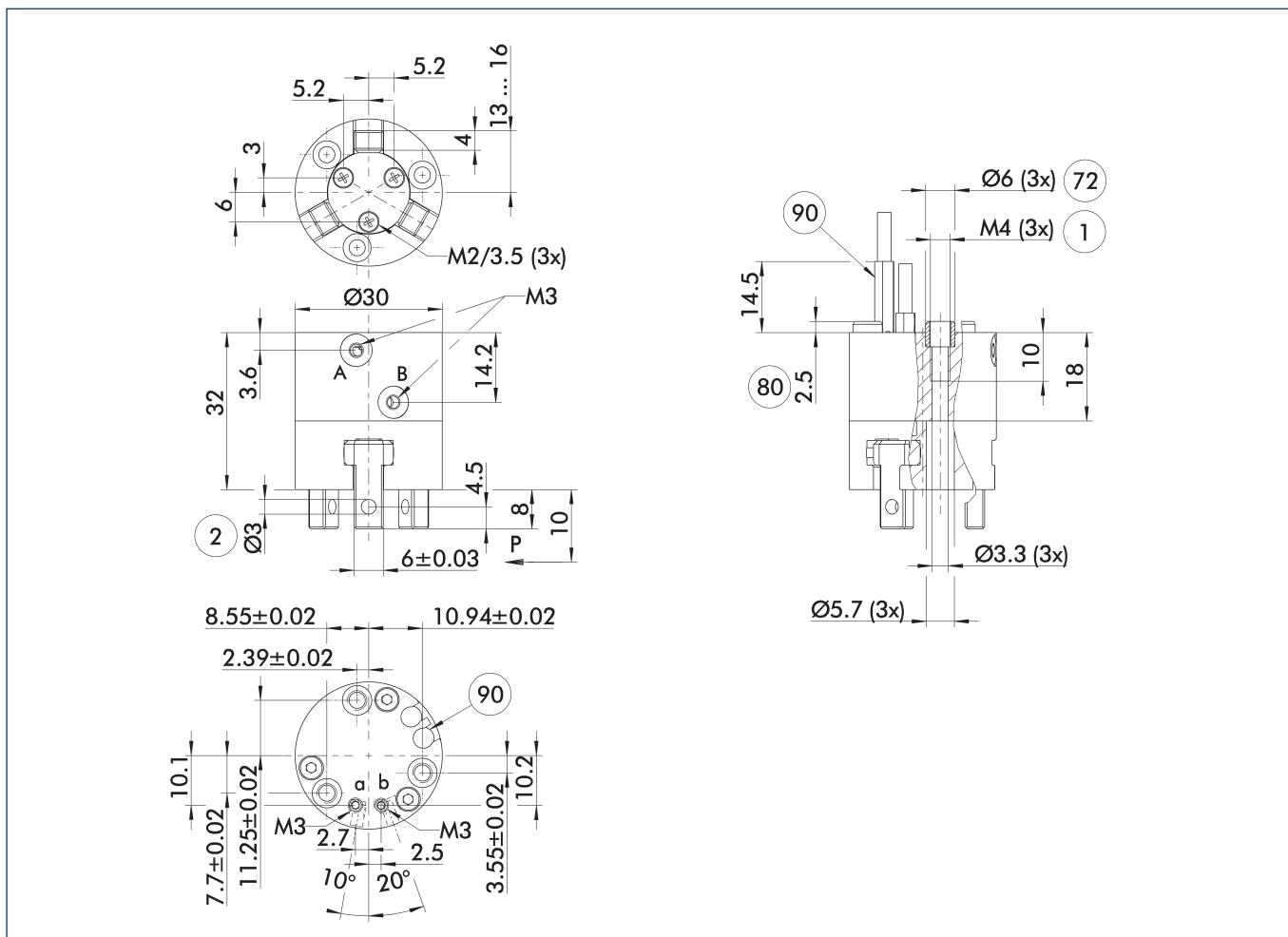

The drawing shows the gripper in the basic version with closed jaws, without dimensional consideration of the options described below.

① The SDV-P pressure maintenance valve can also be used for I.D. or O.D. gripping alternatively or in addition to the spring-loaded, mechanical gripping force maintenance device (see catalog section on accessories).

- A, a Main / direct connection, gripper opening
- B, b Main / direct connection, gripper closing
- ① Gripper connection
- ② Finger connection
- 72 Fit for centering sleeves
- 80 Depth of the centering sleeve hole in the counter part
- 90 Sensor MMS 22..

# MPZ 30

Gripper for small components

## Hose-free direct connection M3

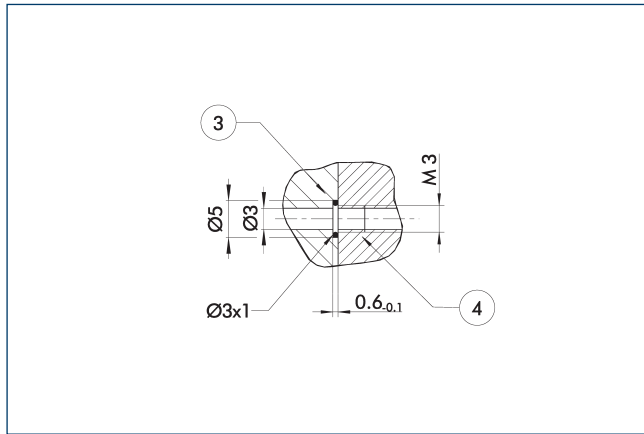

- ③ Adapter
- ④ Grippers

The direct connection is used for supplying compressed air without hoses. Instead, the pressure medium is fed through bore-holes in the mounting plate.

## Gripping force maintenance device AS / IS

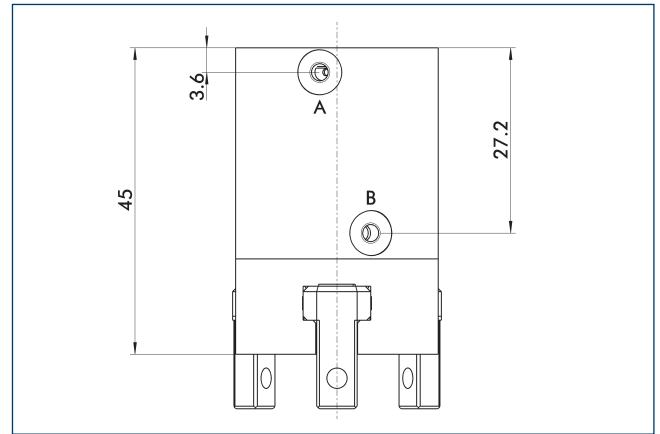

The mechanical gripping force maintenance device ensures that a minimum clamping force will be applied even if there is a drop in pressure. This acts as closing force in the AS / S version, and as opening force in the IS version. Besides this, the gripping force maintenance device can be used to increase the gripping force or for single actuated gripping.

## Flexible position sensor

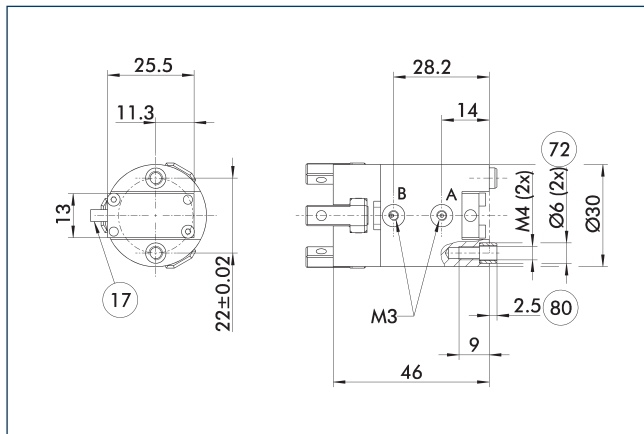

- ①⑦ Cable outlet
- ①⑦ Fit for centering sleeves
- ①⑧ Depth of the centering sleeve hole in the counter part

The following FPS position sensor can differentiate between five programmable areas or switching points for the stroke of a gripper, and can be used in connection with a PC as a measuring system.

## SDV-P pressure maintenance valve

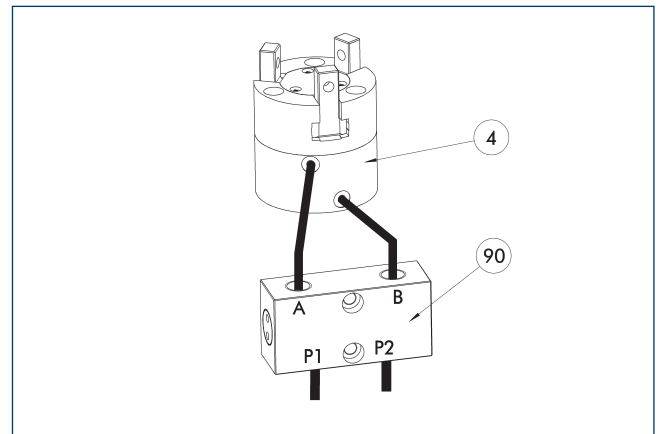

- ④ Grippers
- ⑨⑩ SDV-P pressure maintenance valve

The SDV-P pressure maintenance valve ensures in emergency STOP situations that the pressure in the piston chamber of pneumatic gripper, swivel, linear, and quick-change modules is temporarily maintained.

Description	ID	Recommended hose diameter [mm]
Pressure maintenance valve		
SDV-P 04	0403130	6
Pressure maintenance valve with air bleed screw		
SDV-P 04-E	0300120	6

① In order to achieve the specified closing and opening time for each gripper variant, the recommended hose diameter must be used. The direct allocation of the respective variant of the gripper for the respective SDV-P can be found at [schunk.com](http://schunk.com).

Finger blanks ABR-MPZ 30

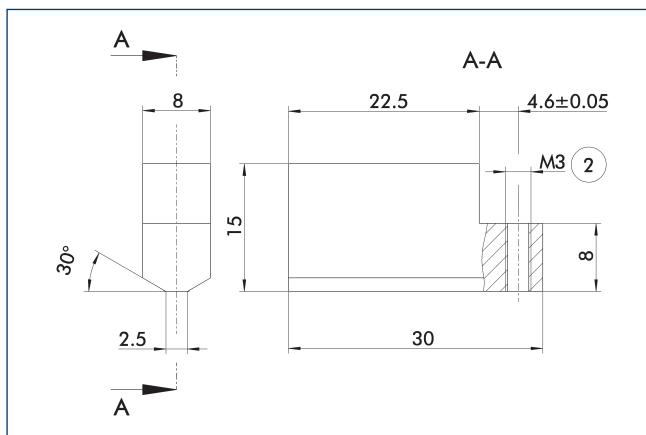

② Finger connection

The drawing shows the finger blank which can be reworked by the customer.

Description	ID	Material	Scope of delivery
Finger blank			
ABR-MPZ 30	0340519	Aluminum	3

Modular Assembly Automation

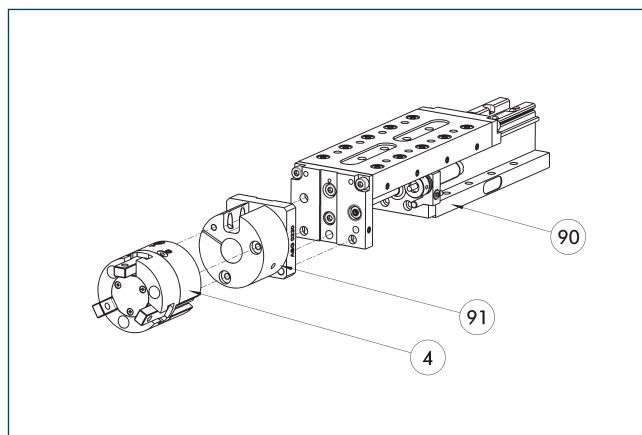

④ Grippers

⑨① ASG adapter plate

⑨② CLM/KLM/LM/ELP/ELM/ELS/HLM linear modules

Grippers and linear modules can be combined with standard adapter plates from the modular assembly system. For more information see our main catalog "Modular Assembly Automation".

Flexible position sensor

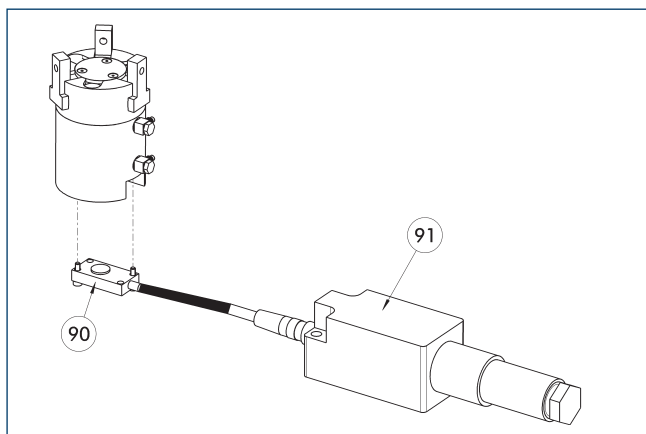

⑨② FPS-S sensor

⑨③ FPS-F5 evaluation electronic

Flexible position monitoring of up to five positions.

Description	ID	Often combined
Sensor		
FPS-S 13	0301705	
Evaluation electronics		
FPS-F5	0301805	●
Cable extension		
KV BG08-SG08 3P-0050	0301598	
KV BG08-SG08 3P-0100	0301599	
Connection cables		
KA BG16-L 12P-1000	0301801	
clip for plug/socket		
CLI-M8	0301463	

① When using an FPS system, an FPS sensor (FPS-S) as well as an electronic processor (FPS-F5 / F5 T) are required for each gripper as well as a mounting kit (AS), if listed. Cable extensions (KV) are optionally available – see catalog chapter "Accessories."

# MPZ 30

Gripper for small components

## Electronic magnetic switch MMS

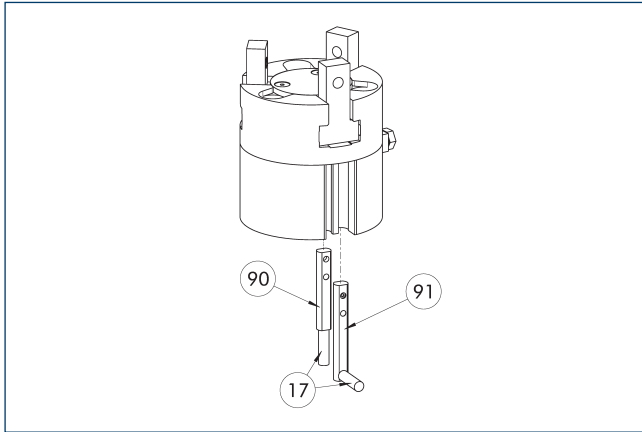

- 17 Cable outlet
- 90 Sensor MMS 22..
- 91 Sensor MMS 22...-SA

End position monitoring for mounting in the C-slot.

Description	ID	Often combined
<b>Electronic magnetic switch</b>		
MMS 22-S-M8-PNP	0301032	●
MMSK 22-S-PNP	0301034	
<b>Electronic magnetic switches with lateral cable outlet</b>		
MMS 22-S-M8-PNP-SA	0301042	●
MMSK 22-S-PNP-SA	0301044	
<b>Reed Switches</b>		
RMS 22-S-M8	0377720	●
<b>Connection cables</b>		
KA BG08-L 3P-0300-PNP	0301622	●
KA BG08-L 3P-0500-PNP	0301623	
KA BW08-L 3P-0300-PNP	0301594	
KA BW08-L 3P-0500-PNP	0301502	
<b>clip for plug/socket</b>		
CLI-M8	0301463	
<b>Wireless sensor system</b>		
RSS-T2	0377715	
RSS-T2-US/CA	0377717	
<b>Cable extension</b>		
KV BW08-SG08 3P-0030-PNP	0301495	
KV BW08-SG08 3P-0100-PNP	0301496	
KV BW08-SG08 3P-0200-PNP	0301497	●
<b>Sensor distributor</b>		
V2-M8	0301775	●
V4-M8	0301746	
V8-M8	0301751	

- ⓘ Two sensors are required per unit for monitoring two positions. On option, extension cables and sensor distributors are available. Additional product variants of the sensor, and further information and technical data can be found in the catalog chapter sensor system.



**Programmable magnetic switch MMS 22-PI1**

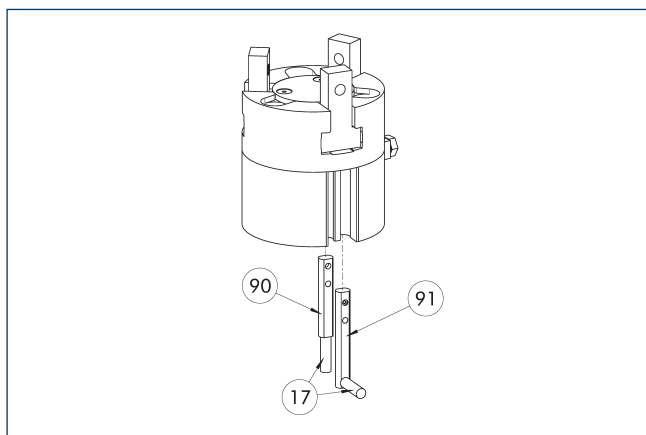

- ⑰ Cable outlet
- ① Sensor MMS 22 ..-PI1-...-SA
- ⑨ Sensor MMS 22 PI1-...

Position monitoring with one programmable position per sensor and integrated electronic system in the sensor. Can be programmed using MT magnetic teaching tool (included in the scope of delivery) or ST plug teaching tool (optional). End position monitoring for mounting in the C-slot. If the ST plug teaching tools are listed in the table provided, teaching is only possible with the ST teaching tools.

Description	ID	Often combined
<b>Programmable magnetic switch</b>		
MMS 22-PI1-S-M8-PNP	0301160	●
MMSK 22-PI1-S-PNP	0301162	
<b>Programmable magnetic switch with lateral cable outlet</b>		
MMS 22-PI1-S-M8-PNP-SA	0301166	●
MMSK 22-PI1-S-PNP-SA	0301168	
<b>Programmable magnetic switch with stainless steel housing</b>		
MMS 22-PI1-S-M8-PNP-HD	0301110	●
MMSK 22-PI1-S-PNP-HD	0301112	

- ① Two sensors are required per unit for monitoring two positions. On option, extension cables and sensor distributors are available. Additional product variants of the sensor, and further information and technical data can be found in the catalog chapter sensor system.

**Programmable magnetic switch MMS 22-PI2**

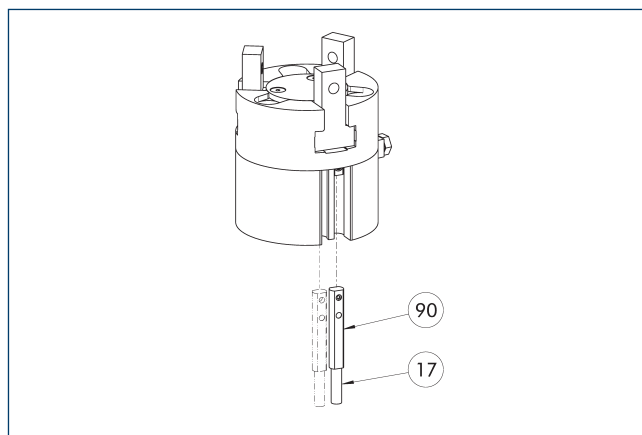

- ⑰ Cable outlet
- ⑨ MMS 22...-PI2-... sensor

Position monitoring with two programmable positions per sensor and electronics built into the sensor. Can be programmed using MT magnetic teaching tool (included in the scope of delivery) or ST plug teaching tool (optional). End position monitoring for mounting in the C-slot. If the ST plug teaching tools are listed in the table provided, teaching is only possible with the ST teaching tools.

Description	ID	Often combined
<b>Programmable magnetic switch</b>		
MMS 22-PI2-S-M8-PNP	0301180	●
MMSK 22-PI2-S-PNP	0301182	
<b>Programmable magnetic switch with lateral cable outlet</b>		
MMS 22-PI2-S-M8-PNP-SA	0301186	●
MMSK 22-PI2-S-PNP-SA	0301188	
<b>Programmable magnetic switch with stainless steel housing</b>		
MMS 22-PI2-S-M8-PNP-HD	0301130	●
MMSK 22-PI2-S-PNP-HD	0301132	

- ① One sensor is required per unit for monitoring two positions. Extension cables and sensor distributors are optionally available. Additional product variants of the sensor, and further information and technical data can be found in the catalog chapter sensor systems.

# MPZ 30

Gripper for small components

## MMS-P programmable magnetic switch

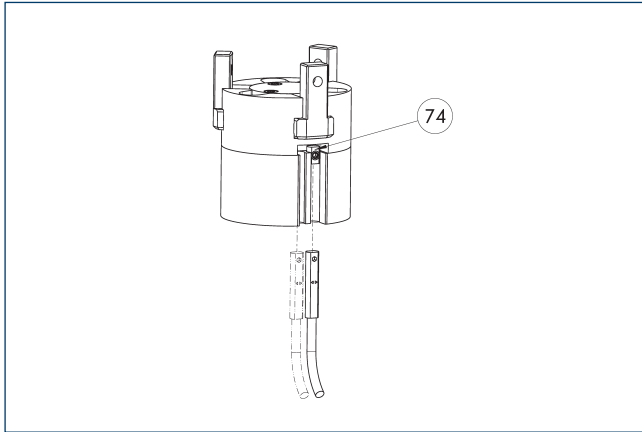

74 Limit stop for sensor

Position monitoring with two programmable positions per sensor. End position monitoring for mounting in the C-slot.

Description	ID	Often combined
Programmable magnetic switch		
MMSK-P 22-S-PNP	0301371	
MMS-P 22-S-M8-PNP	0301370	●
Connection cables		
KA GLN0804-LK-00500-A	0307767	●
KA GLN0804-LK-01000-A	0307768	
KA WLN0804-LK-00500-A	0307765	
KA WLN0804-LK-01000-A	0307766	
clip for plug/socket		
CLI-M8	0301463	
Sensor distributor		
V2-M8-4P-2XM8-3P	0301380	

① One sensor is required per unit for monitoring two positions. Extension cables and sensor distributors are optionally available. Additional product variants of the sensor, and further information and technical data can be found in the catalog chapter sensor systems.

## Programmable magnetic switch MMS-IO-Link

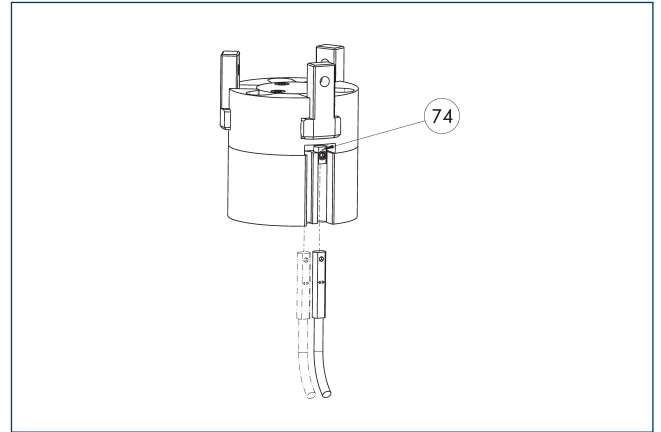

74 Limit stop for sensor

Sensor for multi-position monitoring through detection of the complete gripper stroke. The sensor is mounted directly in the C-slot of the gripper. Sensor programming on the gripper takes place via the IO-Link interface or the MT magnetic teach tool (included in scope of delivery). An IO-Link master is required for operation.

Description	ID	
Programmable magnetic switch		
MMS 22-IO-L-M08	0315830	
MMS 22-IO-L-M12	0315835	

① One sensor is required for each gripper. No additional mounting kit is required – the gripper is equipped for use of the sensor by default. Further information and technical data can be found in the catalog chapter sensor systems.



# MPZ 38

Gripper for small components



## Gripping force O.D. gripping

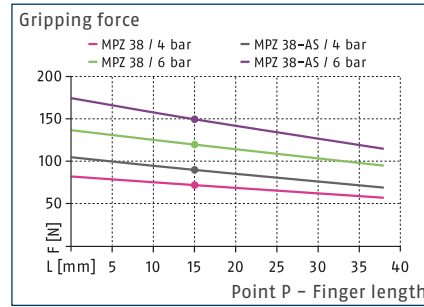

## Gripping force I.D. gripping

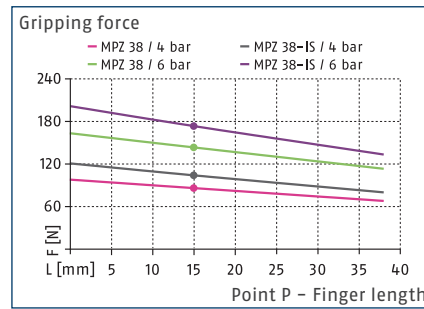

## Dimensions and maximum loads

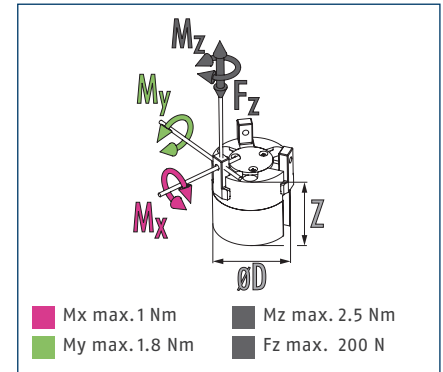

ⓘ The indicated moments and forces are static values, apply for each base jaw and may appear simultaneously. Loads may additionally occur to the moment produced by the gripping force itself.

## Technical data

Description		MPZ 38	MPZ 38-FPS	MPZ 38-AS	MPZ 38-IS
ID		0340520	0340523	0340521	0340522
Stroke per jaw	[mm]	4	4	4	4
Closing/opening force	[N]	120/140	120/140	150/-	-/180
Min. spring force	[N]			30	40
Weight	[kg]	0.14	0.19	0.19	0.19
Recommended workpiece weight	[kg]	0.6	0.6	0.6	0.6
Fluid consumption double stroke	[cm <sup>3</sup> ]	3.5	3.5	10.3	8.4
Min./nom./max. operating pressure	[bar]	2/6/8	2/6/8	4/6/6.5	4/6/6.5
Closing/opening time	[s]	0.02/0.02	0.02/0.02	0.02/0.04	0.04/0.02
Closing/opening time with spring	[s]			0.20	0.20
Max. permissible finger length	[mm]	38	38	38	38
Max. permissible mass per finger	[kg]	0.05	0.05	0.05	0.05
IP protection class		40	40	40	40
Min./max. ambient temperature	[°C]	5/90	5/90	5/90	5/90
Repeat accuracy	[mm]	0.01	0.01	0.01	0.01
Cleanroom class ISO 14644-1:1999		5	5	5	5
Dimensions Ø D x Z	[mm]	38 x 38	38 x 53	38 x 59	38 x 59
<b>Options and their characteristics</b>					
H1 grease version		30046783	1475823	1441506	30047905

ⓘ It may take a few 100 gripping cycles until the full gripping force (as indicated in the data table) will be available.

## Main view

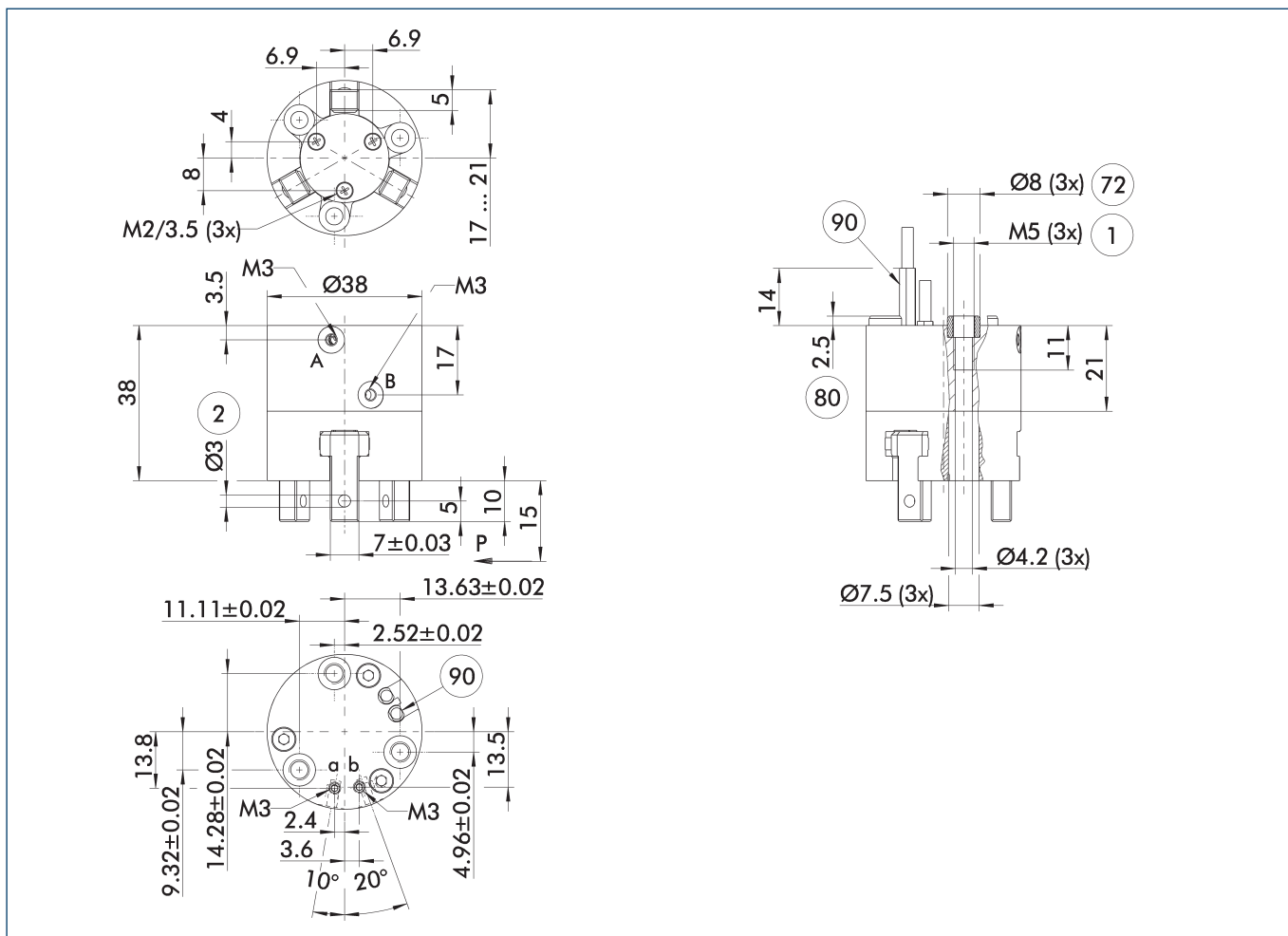

The drawing shows the gripper in the basic version with closed jaws, without dimensional consideration of the options described below.

① The SDV-P pressure maintenance valve can also be used for I.D. or O.D. gripping alternatively or in addition to the spring-loaded, mechanical gripping force maintenance device (see catalog section on accessories).

A, a Main / direct connection, gripper opening

B, b Main / direct connection, gripper closing

① Gripper connection

② Finger connection

⑦ Fit for centering sleeves

⑧ Depth of the centering sleeve hole in the counter part

⑨ Sensor MMS 22..



## Finger blanks ABR-MPZ 38

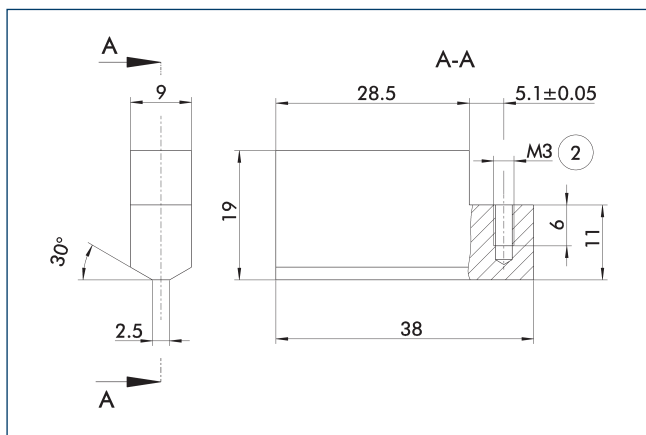

### ② Finger connection

The drawing shows the finger blank which can be reworked by the customer.

Description	ID	Material	Scope of delivery
Finger blank			
ABR-MPZ 38	0340529	Aluminum	3

## Modular Assembly Automation

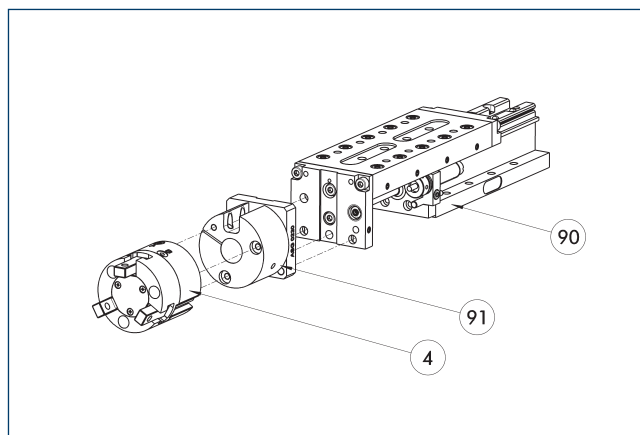

### ④ Grippers

### ⑨① ASG adapter plate

### ⑨② CLM/KLM/LM/ELP/ELM/ELS/HLM linear modules

Grippers and linear modules can be combined with standard adapter plates from the modular assembly system. For more information see our main catalog "Modular Assembly Automation".

## Flexible position sensor

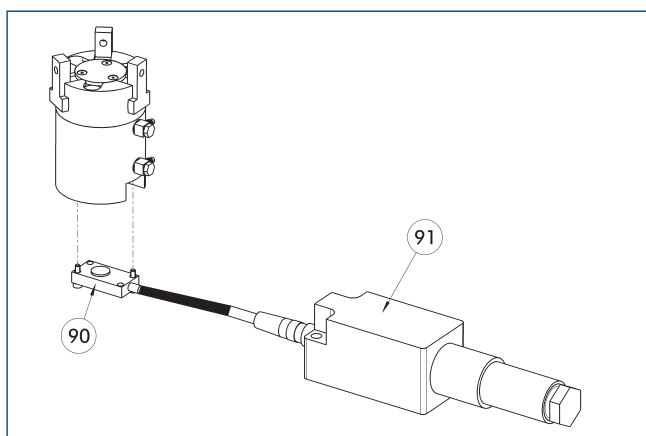

### ⑨② FPS-S sensor

### ⑨① FPS-F5 evaluation electronic

Flexible position monitoring of up to five positions.

Description	ID	Often combined
Sensor		
FPS-S 13	0301705	
Evaluation electronics		
FPS-F5	0301805	●
Cable extension		
KV BG08-SG08 3P-0050	0301598	
KV BG08-SG08 3P-0100	0301599	
Connection cables		
KA BG16-L 12P-1000	0301801	
clip for plug/socket		
CLI-M8	0301463	

① When using an FPS system, an FPS sensor (FPS-S) as well as an electronic processor (FPS-F5 / F5 T) are required for each gripper as well as a mounting kit (AS), if listed. Cable extensions (KV) are optionally available – see catalog chapter "Accessories."

# MPZ 38

Gripper for small components

## Electronic magnetic switch MMS

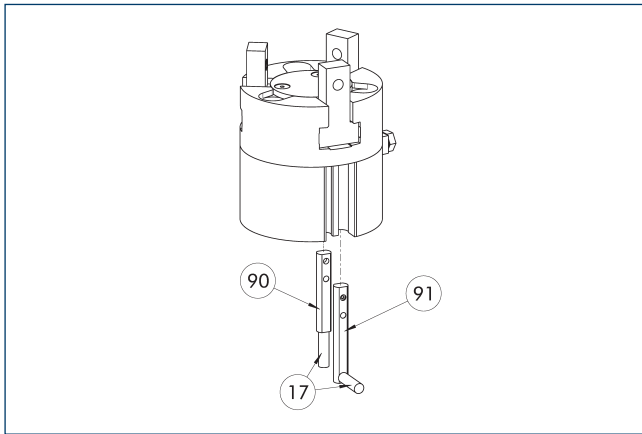

- ①⑦ Cable outlet
- ①⑨ Sensor MMS 22...-SA
- ①⑩ Sensor MMS 22..

End position monitoring for mounting in the C-slot.

Description	ID	Often combined
<b>Electronic magnetic switch</b>		
MMS 22-S-M8-PNP	0301032	●
MMSK 22-S-PNP	0301034	
<b>Electronic magnetic switches with lateral cable outlet</b>		
MMS 22-S-M8-PNP-SA	0301042	●
MMSK 22-S-PNP-SA	0301044	
<b>Connection cables</b>		
KA BG08-L 3P-0300-PNP	0301622	●
KA BG08-L 3P-0500-PNP	0301623	
KA BW08-L 3P-0300-PNP	0301594	
KA BW08-L 3P-0500-PNP	0301502	
<b>clip for plug/socket</b>		
CLI-M8	0301463	
<b>Cable extension</b>		
KV BW08-SG08 3P-0030-PNP	0301495	
KV BW08-SG08 3P-0100-PNP	0301496	
KV BW08-SG08 3P-0200-PNP	0301497	●
<b>Sensor distributor</b>		
V2-M8	0301775	●
V4-M8	0301746	
V8-M8	0301751	

- ① Two sensors are required per unit for monitoring two positions. On option, extension cables and sensor distributors are available. Additional product variants of the sensor, and further information and technical data can be found in the catalog chapter sensor system.



**Programmable magnetic switch MMS 22-PI1**

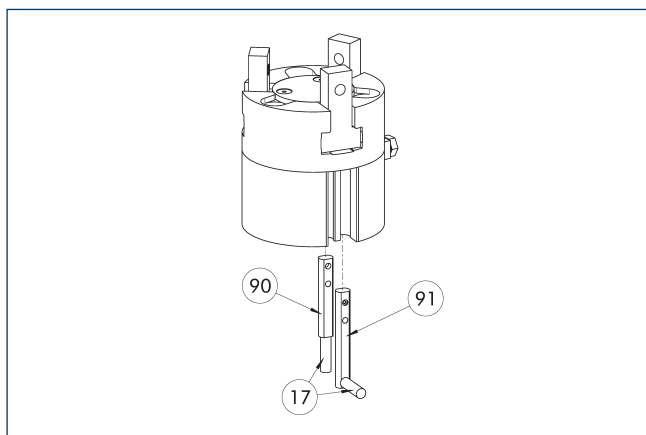

- ⑰ Cable outlet
- ⑲① Sensor MMS 22 ..-PI1-...-SA
- ⑲② Sensor MMS 22 PI1-...

Position monitoring with one programmable position per sensor and integrated electronic system in the sensor. Can be programmed using MT magnetic teaching tool (included in the scope of delivery) or ST plug teaching tool (optional). End position monitoring for mounting in the C-slot. If the ST plug teaching tools are listed in the table provided, teaching is only possible with the ST teaching tools.

Description	ID	Often combined
<b>Programmable magnetic switch</b>		
MMS 22-PI1-S-M8-PNP	0301160	●
MMSK 22-PI1-S-PNP	0301162	
<b>Programmable magnetic switch with lateral cable outlet</b>		
MMS 22-PI1-S-M8-PNP-SA	0301166	●
MMSK 22-PI1-S-PNP-SA	0301168	
<b>Programmable magnetic switch with stainless steel housing</b>		
MMS 22-PI1-S-M8-PNP-HD	0301110	●
MMSK 22-PI1-S-PNP-HD	0301112	

⑰ Two sensors are required per unit for monitoring two positions. On option, extension cables and sensor distributors are available. Additional product variants of the sensor, and further information and technical data can be found in the catalog chapter sensor system.

**Programmable magnetic switch MMS 22-PI2**

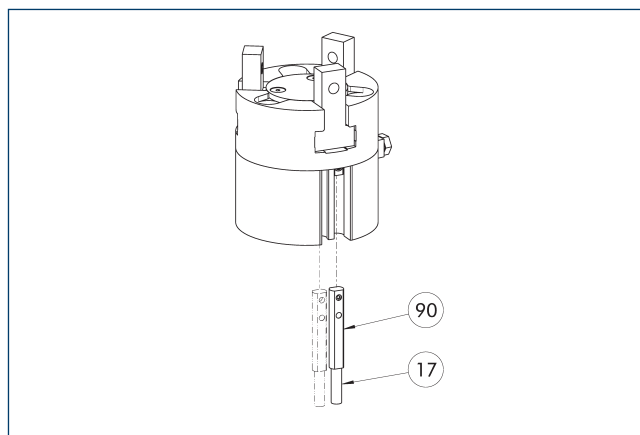

- ⑰ Cable outlet
- ⑲② MMS 22...-PI2-... sensor

Position monitoring with two programmable positions per sensor and electronics built into the sensor. Can be programmed using MT magnetic teaching tool (included in the scope of delivery) or ST plug teaching tool (optional). End position monitoring for mounting in the C-slot. If the ST plug teaching tools are listed in the table provided, teaching is only possible with the ST teaching tools.

Description	ID	Often combined
<b>Programmable magnetic switch</b>		
MMS 22-PI2-S-M8-PNP	0301180	●
MMSK 22-PI2-S-PNP	0301182	
<b>Programmable magnetic switch with lateral cable outlet</b>		
MMS 22-PI2-S-M8-PNP-SA	0301186	●
MMSK 22-PI2-S-PNP-SA	0301188	
<b>Programmable magnetic switch with stainless steel housing</b>		
MMS 22-PI2-S-M8-PNP-HD	0301130	●
MMSK 22-PI2-S-PNP-HD	0301132	

⑰ One sensor is required per unit for monitoring two positions. Extension cables and sensor distributors are optionally available. Additional product variants of the sensor, and further information and technical data can be found in the catalog chapter sensor systems.

# MPZ 38

Gripper for small components

## MMS-P programmable magnetic switch

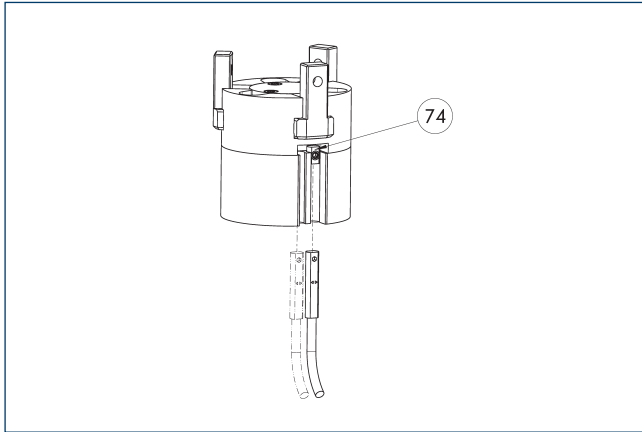

74 Limit stop for sensor

Position monitoring with two programmable positions per sensor. End position monitoring for mounting in the C-slot.

Description	ID	Often combined
Programmable magnetic switch		
MMSK-P 22-S-PNP	0301371	
MMS-P 22-S-M8-PNP	0301370	●
Connection cables		
KA GLN0804-LK-00500-A	0307767	●
KA GLN0804-LK-01000-A	0307768	
KA WLN0804-LK-00500-A	0307765	
KA WLN0804-LK-01000-A	0307766	
clip for plug/socket		
CLI-M8	0301463	
Sensor distributor		
V2-M8-4P-2XM8-3P	0301380	

① One sensor is required per unit for monitoring two positions. Extension cables and sensor distributors are optionally available. Additional product variants of the sensor, and further information and technical data can be found in the catalog chapter sensor systems.

## Programmable magnetic switch MMS-IO-Link

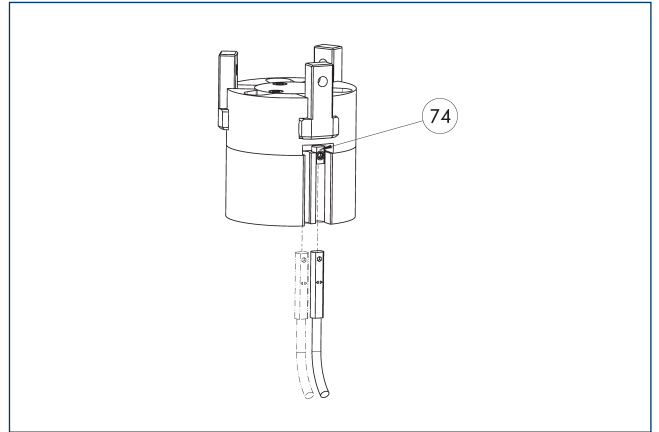

74 Limit stop for sensor

Sensor for multi-position monitoring through detection of the complete gripper stroke. The sensor is mounted directly in the C-slot of the gripper. Sensor programming on the gripper takes place via the IO-Link interface or the MT magnetic teach tool (included in scope of delivery). An IO-Link master is required for operation.

Description	ID	
Programmable magnetic switch		
MMS 22-IO-L-M08	0315830	
MMS 22-IO-L-M12	0315835	

① One sensor is required for each gripper. No additional mounting kit is required – the gripper is equipped for use of the sensor by default. Further information and technical data can be found in the catalog chapter sensor systems.



# MPZ 45

Gripper for small components



## Gripping force O.D. gripping

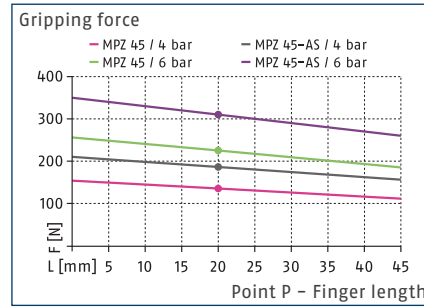

## Gripping force I.D. gripping

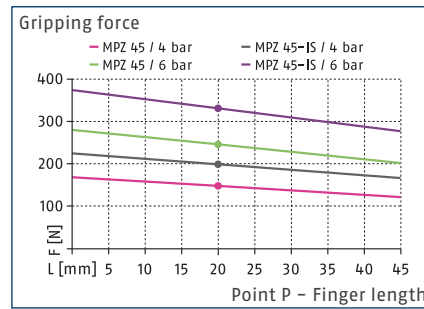

## Dimensions and maximum loads

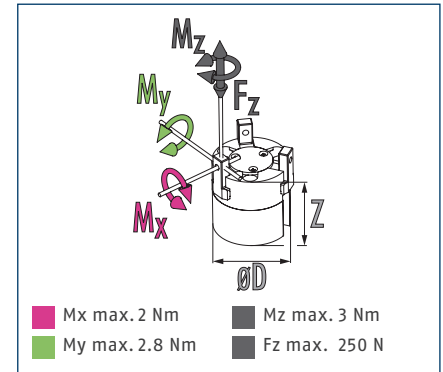

① The indicated moments and forces are static values, apply for each base jaw and may appear simultaneously. Loads may additionally occur to the moment produced by the gripping force itself.

## Technical data

Description		MPZ 45	MPZ 45-FPS	MPZ 45-AS	MPZ 45-IS
ID		0340530	0340533	0340531	0340532
Stroke per jaw	[mm]	5	5	5	5
Closing/opening force	[N]	225/245	225/245	310/-	-/340
Min. spring force	[N]			85	95
Weight	[kg]	0.22	0.29	0.28	0.28
Recommended workpiece weight	[kg]	1.15	1.15	1.15	1.15
Fluid consumption double stroke	[cm <sup>3</sup> ]	8.9	8.9	18.4	15.2
Min./nom./max. operating pressure	[bar]	2/6/8	2/6/8	4/6/6.5	4/6/6.5
Closing/opening time	[s]	0.05/0.05	0.05/0.05	0.05/0.06	0.06/0.05
Closing/opening time with spring	[s]			0.30	0.30
Max. permissible finger length	[mm]	45	45	45	45
Max. permissible mass per finger	[kg]	0.08	0.08	0.08	0.08
IP protection class		40	40	40	40
Min./max. ambient temperature	[°C]	5/90	5/90	5/90	5/90
Repeat accuracy	[mm]	0.01	0.01	0.01	0.01
Cleanroom class ISO 14644-1:1999		5	5	5	5
Dimensions Ø D x Z	[mm]	45 x 43	45 x 60	45 x 58	45 x 58
<b>Options and their characteristics</b>					
H1 grease version		30047560	1475826	1475824	1475825

① It may take a few 100 gripping cycles until the full gripping force (as indicated in the data table) will be available.

## Main view

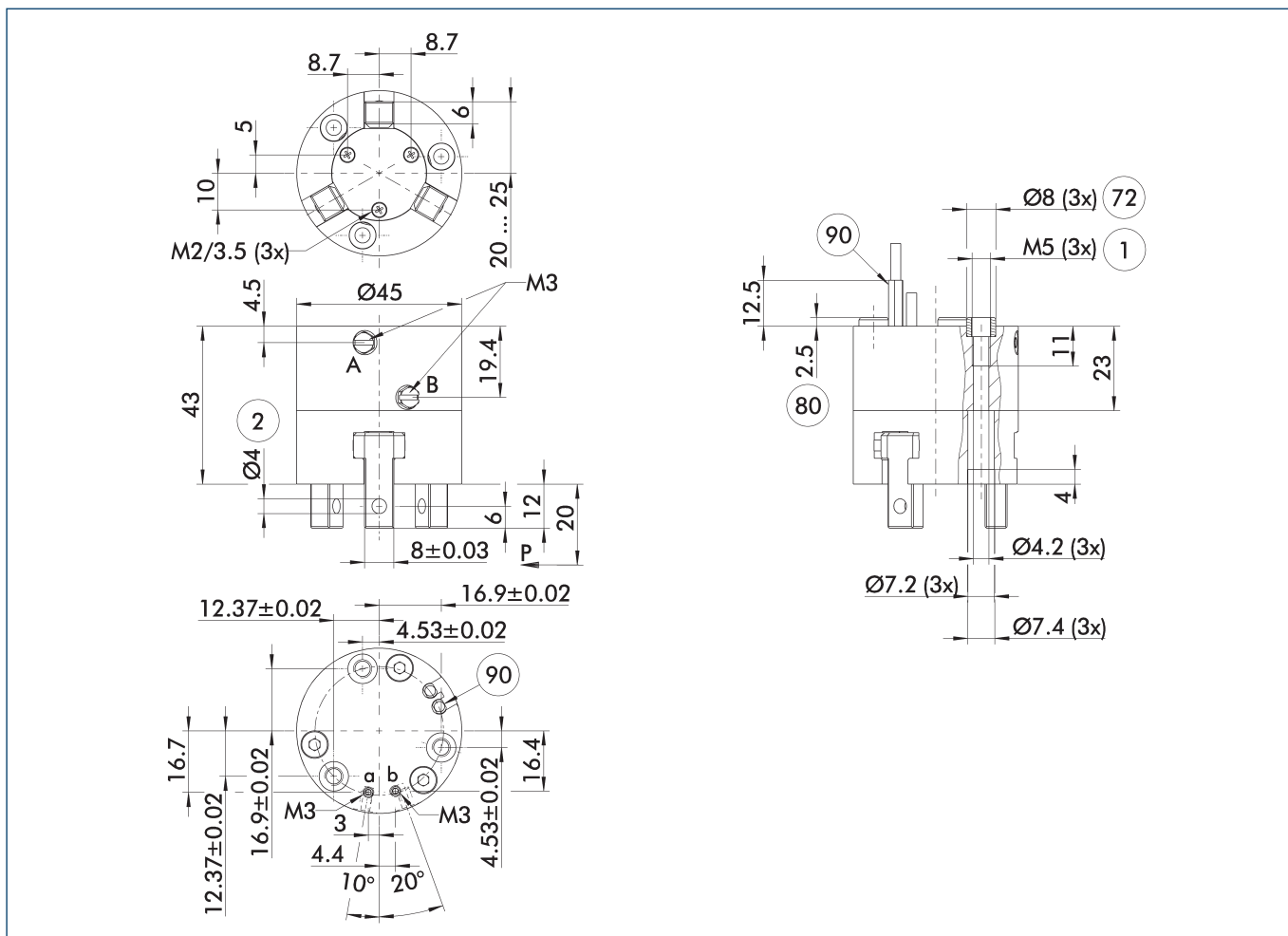

The drawing shows the gripper in the basic version with closed jaws, without dimensional consideration of the options described below.

① The SDV-P pressure maintenance valve can also be used for I.D. or O.D. gripping alternatively or in addition to the spring-loaded, mechanical gripping force maintenance device (see catalog section on accessories).

A, a Main / direct connection, gripper opening

B, b Main / direct connection, gripper closing

① Gripper connection

② Finger connection

⑦ Fit for centering sleeves

⑧ Depth of the centering sleeve hole in the counter part

⑨ Sensor MMS 22..

# MPZ 45

Gripper for small components

## Hose-free direct connection M3

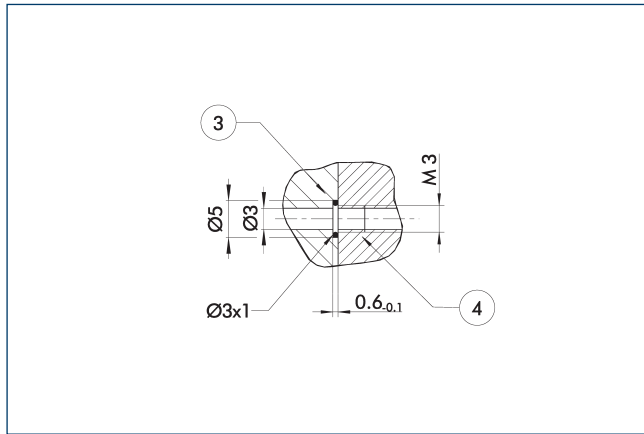

- ③ Adapter
- ④ Grippers

The direct connection is used for supplying compressed air without hoses. Instead, the pressure medium is fed through bore-holes in the mounting plate.

## Flexible position sensor

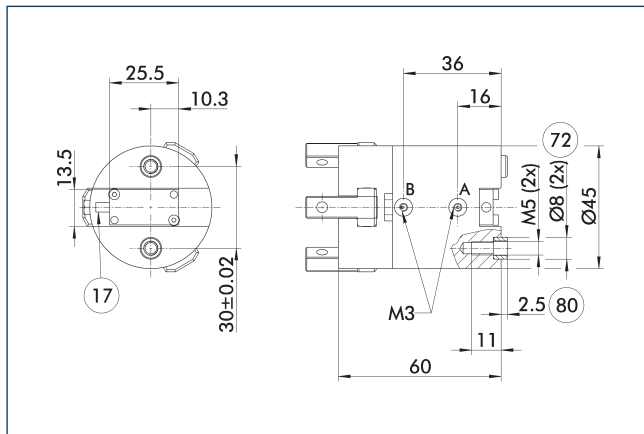

- ①⑦ Cable outlet
- ①⑦ Fit for centering sleeves
- ①⑧ Depth of the centering sleeve hole in the counter part

The following FPS position sensor can differentiate between five programmable areas or switching points for the stroke of a gripper, and can be used in connection with a PC as a measuring system.

## Gripping force maintenance device AS / IS

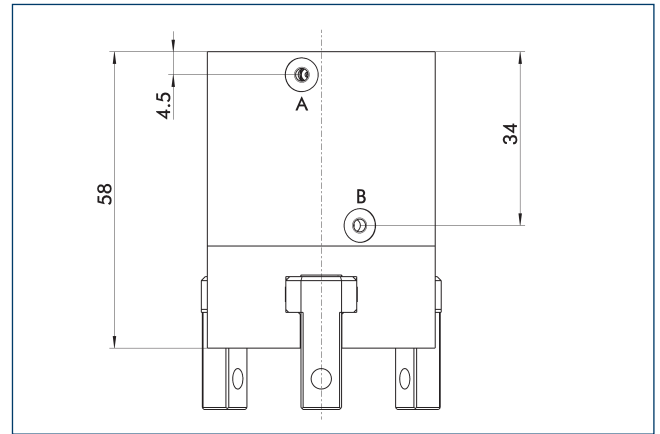

The mechanical gripping force maintenance device ensures that a minimum clamping force will be applied even if there is a drop in pressure. This acts as closing force in the AS / S version, and as opening force in the IS version. Besides this, the gripping force maintenance device can be used to increase the gripping force or for single actuated gripping.

## SDV-P pressure maintenance valve

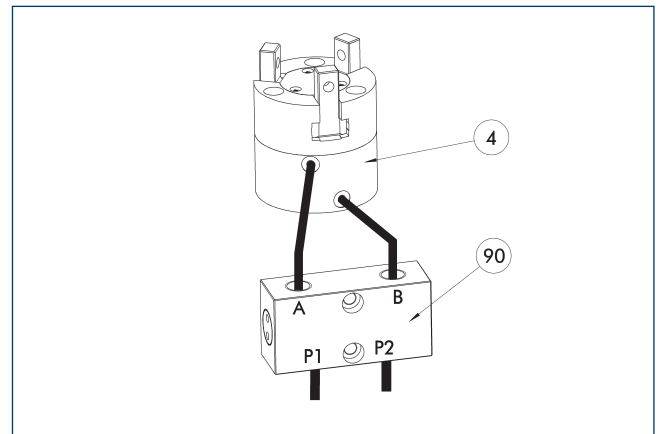

- ④ Grippers
- ①⑨ SDV-P pressure maintenance valve

The SDV-P pressure maintenance valve ensures in emergency STOP situations that the pressure in the piston chamber of pneumatic gripper, swivel, linear, and quick-change modules is temporarily maintained.

Description	ID	Recommended hose diameter [mm]
Pressure maintenance valve		
SDV-P 04	0403130	6
Pressure maintenance valve with air bleed screw		
SDV-P 04-E	0300120	6

① In order to achieve the specified closing and opening time for each gripper variant, the recommended hose diameter must be used. The direct allocation of the respective variant of the gripper for the respective SDV-P can be found at [schunk.com](http://schunk.com).

Finger blanks ABR-MPZ 45

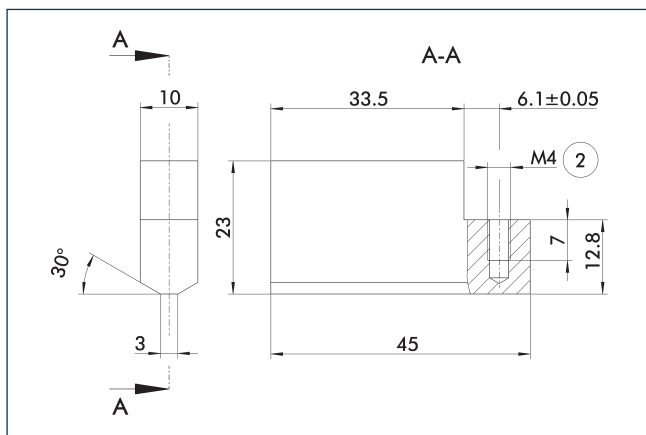

② Finger connection

The drawing shows the finger blank which can be reworked by the customer.

Description	ID	Material	Scope of delivery
Finger blank			
ABR-MPZ 45	0340539	Aluminum	3

Modular Assembly Automation

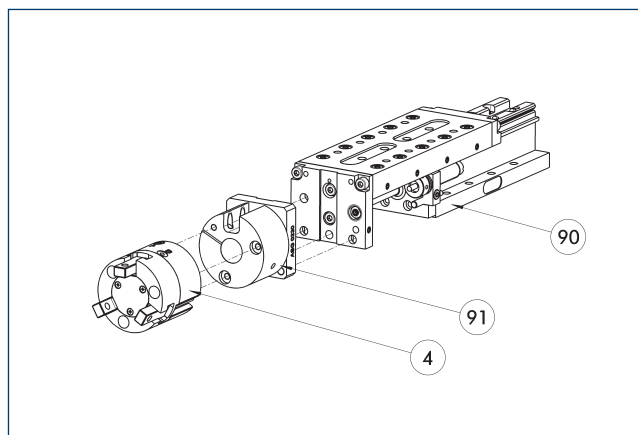

④ Grippers

⑨① ASG adapter plate

⑨② CLM/KLM/LM/ELP/ELM/ELS/HLM linear modules

Grippers and linear modules can be combined with standard adapter plates from the modular assembly system. For more information see our main catalog "Modular Assembly Automation".

Flexible position sensor

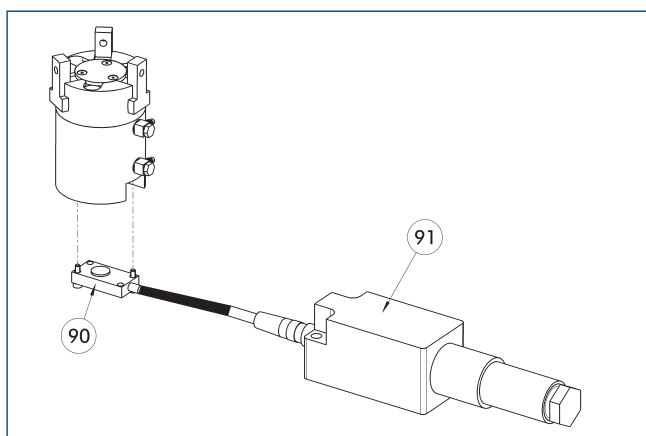

⑨② FPS-S sensor

⑨① FPS-F5 evaluation electronic

Flexible position monitoring of up to five positions.

Description	ID	Often combined
Sensor		
FPS-S 13	0301705	
Evaluation electronics		
FPS-F5	0301805	●
Cable extension		
KV BG08-SG08 3P-0050	0301598	
KV BG08-SG08 3P-0100	0301599	
Connection cables		
KA BG16-L 12P-1000	0301801	
clip for plug/socket		
CLI-M8	0301463	

① When using an FPS system, an FPS sensor (FPS-S) as well as an electronic processor (FPS-F5 / F5 T) are required for each gripper as well as a mounting kit (AS), if listed. Cable extensions (KV) are optionally available – see catalog chapter "Accessories."

# MPZ 45

Gripper for small components

## Electronic magnetic switch MMS

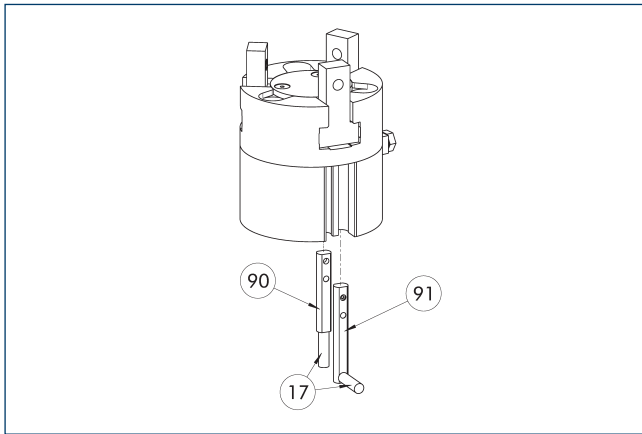

- ①⑦ Cable outlet
- ①⑨ Sensor MMS 22...-SA
- ①⑩ Sensor MMS 22..

End position monitoring for mounting in the C-slot.

Description	ID	Often combined
<b>Electronic magnetic switch</b>		
MMS 22-S-M8-PNP	0301032	●
MMSK 22-S-PNP	0301034	
<b>Electronic magnetic switches with lateral cable outlet</b>		
MMS 22-S-M8-PNP-SA	0301042	●
MMSK 22-S-PNP-SA	0301044	
<b>Connection cables</b>		
KA BG08-L 3P-0300-PNP	0301622	●
KA BG08-L 3P-0500-PNP	0301623	
KA BW08-L 3P-0300-PNP	0301594	
KA BW08-L 3P-0500-PNP	0301502	
<b>clip for plug/socket</b>		
CLI-M8	0301463	
<b>Cable extension</b>		
KV BW08-SG08 3P-0030-PNP	0301495	
KV BW08-SG08 3P-0100-PNP	0301496	
KV BW08-SG08 3P-0200-PNP	0301497	●
<b>Sensor distributor</b>		
V2-M8	0301775	●
V4-M8	0301746	
V8-M8	0301751	

- ① Two sensors are required per unit for monitoring two positions. On option, extension cables and sensor distributors are available. Additional product variants of the sensor, and further information and technical data can be found in the catalog chapter sensor system.



**Programmable magnetic switch MMS 22-PI1**

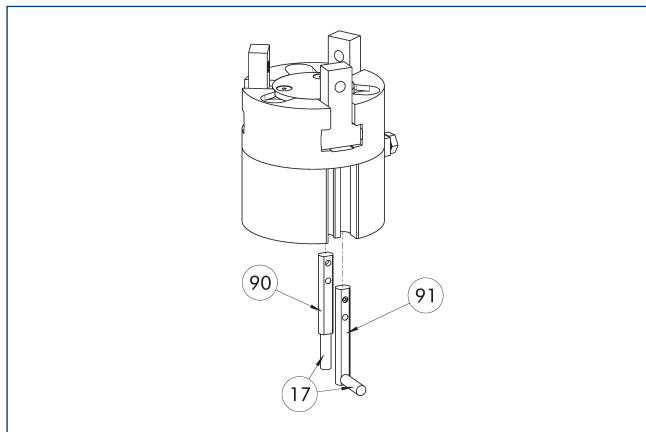

- ⑰ Cable outlet
- ① Sensor MMS 22 ..-PI1-...-SA
- ⑨ Sensor MMS 22 PI1-...

Position monitoring with one programmable position per sensor and integrated electronic system in the sensor. Can be programmed using MT magnetic teaching tool (included in the scope of delivery) or ST plug teaching tool (optional). End position monitoring for mounting in the C-slot. If the ST plug teaching tools are listed in the table provided, teaching is only possible with the ST teaching tools.

Description	ID	Often combined
<b>Programmable magnetic switch</b>		
MMS 22-PI1-S-M8-PNP	0301160	●
MMSK 22-PI1-S-PNP	0301162	
<b>Programmable magnetic switch with lateral cable outlet</b>		
MMS 22-PI1-S-M8-PNP-SA	0301166	●
MMSK 22-PI1-S-PNP-SA	0301168	
<b>Programmable magnetic switch with stainless steel housing</b>		
MMS 22-PI1-S-M8-PNP-HD	0301110	●
MMSK 22-PI1-S-PNP-HD	0301112	

① Two sensors are required per unit for monitoring two positions. On option, extension cables and sensor distributors are available. Additional product variants of the sensor, and further information and technical data can be found in the catalog chapter sensor system.

**Programmable magnetic switch MMS 22-PI2**

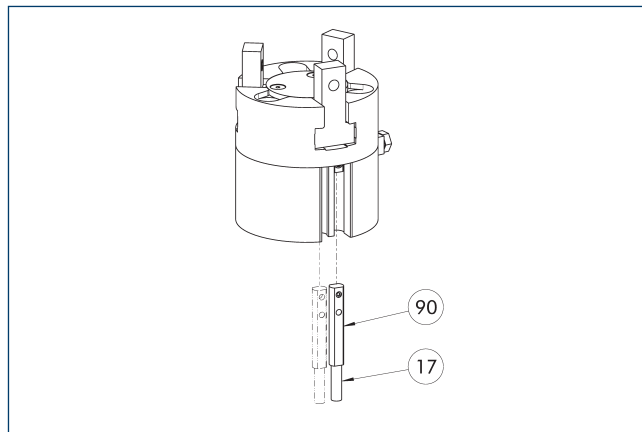

- ⑰ Cable outlet
- ⑨ MMS 22...-PI2-... sensor

Position monitoring with two programmable positions per sensor and electronics built into the sensor. Can be programmed using MT magnetic teaching tool (included in the scope of delivery) or ST plug teaching tool (optional). End position monitoring for mounting in the C-slot. If the ST plug teaching tools are listed in the table provided, teaching is only possible with the ST teaching tools.

Description	ID	Often combined
<b>Programmable magnetic switch</b>		
MMS 22-PI2-S-M8-PNP	0301180	●
MMSK 22-PI2-S-PNP	0301182	
<b>Programmable magnetic switch with lateral cable outlet</b>		
MMS 22-PI2-S-M8-PNP-SA	0301186	●
MMSK 22-PI2-S-PNP-SA	0301188	
<b>Programmable magnetic switch with stainless steel housing</b>		
MMS 22-PI2-S-M8-PNP-HD	0301130	●
MMSK 22-PI2-S-PNP-HD	0301132	

① One sensor is required per unit for monitoring two positions. Extension cables and sensor distributors are optionally available. Additional product variants of the sensor, and further information and technical data can be found in the catalog chapter sensor systems.

## MMS-P programmable magnetic switch

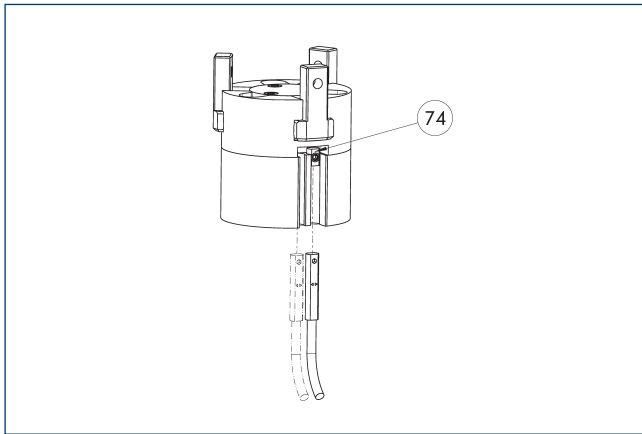

74 Limit stop for sensor

Position monitoring with two programmable positions per sensor. End position monitoring for mounting in the C-slot.

Description	ID	Often combined
Programmable magnetic switch		
MMSK-P 22-S-PNP	0301371	
MMS-P 22-S-M8-PNP	0301370	●
Connection cables		
KA GLN0804-LK-00500-A	0307767	●
KA GLN0804-LK-01000-A	0307768	
KA WLN0804-LK-00500-A	0307765	
KA WLN0804-LK-01000-A	0307766	
clip for plug/socket		
CLI-M8	0301463	
Sensor distributor		
V2-M8-4P-2XM8-3P	0301380	

① One sensor is required per unit for monitoring two positions. Extension cables and sensor distributors are optionally available. Additional product variants of the sensor, and further information and technical data can be found in the catalog chapter sensor systems.





**SCHUNK GmbH & Co. KG**  
**Spann- und Greiftechnik**

Bahnhofstr. 106 - 134  
D-74348 Lauffen/Neckar  
Tel. +49-7133-103-0  
Fax +49-7133-103-2399  
info@de.schunk.com  
schunk.com

Folgen Sie uns | *Follow us*

