



Superior Clamping and Gripping



## Product Information

Angular parallel gripper GAP 28

# GAP

Angular parallel gripper

## Flexible. Productive. Slim.

### Angular parallel gripper GAP

2-finger angular parallel gripper with gripper finger actuation of up to 90° per jaw

#### Field of application

Gripping and moving small to medium workpieces in low contamination environments

#### Advantages – Your benefits

**Positively driven angle and parallel stroke** in one functional unit

**Absolutely clamping in parallel stroke** for highest positioning accuracy

**Stable kinematics** for high power transmission and synchronized gripping

**High gripping force** in parallel stroke

**Opening angle of jaws up to 180°** for maximum flexibility in applications

**Integration of a gripping force maintenance is optional** for firm grip even in the event of power failure

**End-position monitoring** with optional standardized monitoring sets

**Standardized mounting bores** for numerous combinations with other components from the modular system



Sizes  
Quantity: 3



Weight  
0.3 .. 1.33 kg



Gripping force  
92 .. 430 N



Stroke per jaw  
1 .. 2 mm



Workpiece weight  
0.46 .. 1.25 kg

## Functional description

The piston is moved up or down with compressed air. The base jaws are first put into a rotating and then into a parallel movement via the toggle-lever kinematics.

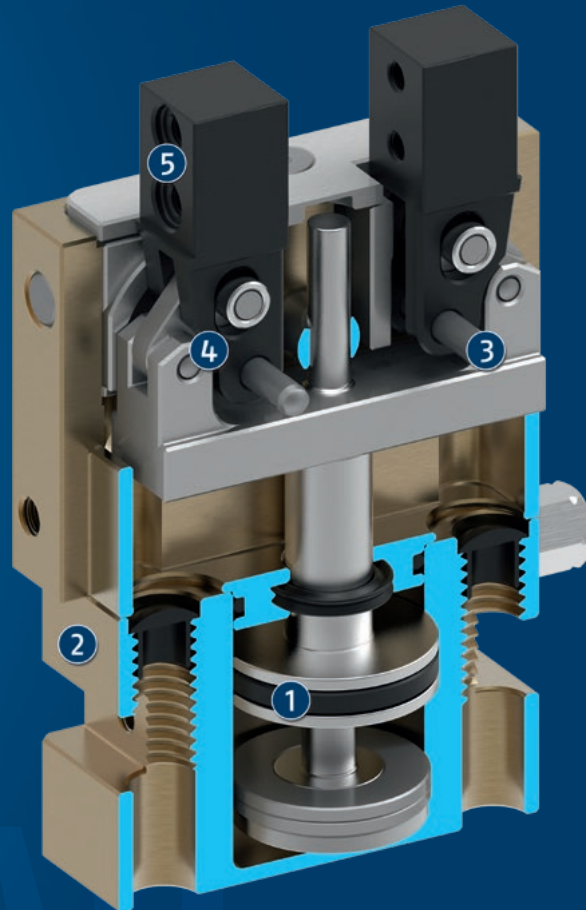

- ① **Drive**  
double-acting piston drive system
- ② **Housing**  
is weight-optimized due to the use of high-strength aluminum alloy
- ③ **Base jaw seated**  
for rotary movement over hardened cylindrical pivot pins
- ④ **Kinematics**  
Positively driven toggle-joint kinematics for rotating and parallel movement
- ⑤ **Base Jaws**  
for the connection of workpiece-specific gripper fingers

# GAP

Angular parallel gripper

## General notes about the series

**Operating principle:** Positively driven toggle-joint kinematics

**Housing material:** Aluminum alloy, anodized

**Base jaw material:** Steel

**Actuation:** pneumatic, with filtered compressed air as per ISO 8573-1:2010 [7:4:4].

**Warranty:** 24 months

**Scope of delivery:** Centering sleeves, O-rings for direct connection, assembly instructions (operating manual with declaration of incorporation is available online)

**Gripping force maintenance device:** possible by using the version with mechanical gripping force maintenance or pressure maintenance valve SDV-P

**Gripping force:** is the arithmetic sum of the individual force applied to each jaw at distance P (see illustration).

**Finger length:** is measured from the reference surface as the distance P in direction to the main axis.

The maximum permissible finger length applies until the nominal operating pressure is achieved. With higher pressures, the finger length must be reduced proportionally to the nominal operating pressure.

**Repeat accuracy:** is defined as a distribution of the end Position for 100 consecutive strokes.

**Workpiece weight:** is calculated for force-fit gripping with a coefficient of static friction of 0.1 and a safety factor of 2 against workpiece slippage at acceleration due to gravity g. For form-fit or capture gripping, there are significantly higher permissible workpiece weights.

**Closing and opening times:** are purely the times that the base jaws or fingers are in motion. Valve switching times, hose fill times, or PLC reaction times are not included, and are to be considered when cycle times are calculated.

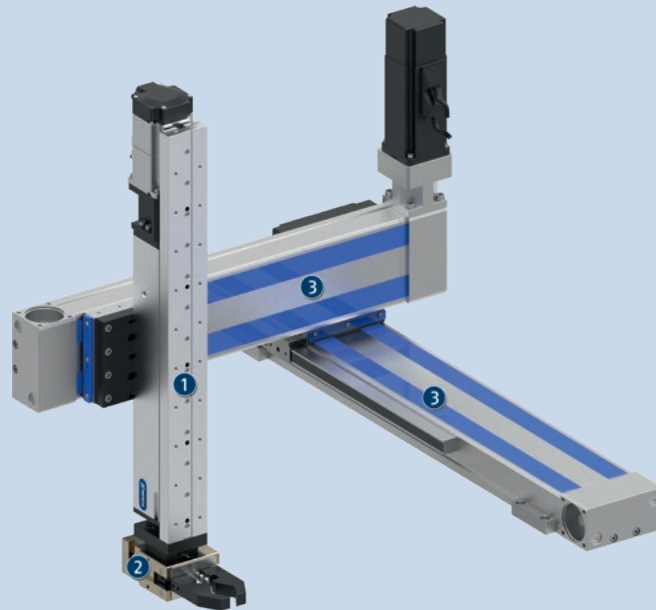

## Application example

Electric linear gantry to center or reposition small components.

- ① Compact linear module ELS
- ② 2-finger angular parallel gripper GAP
- ③ Flat linear module Delta with toothed-belt drive

## SCHUNK offers more ...

The following components make the product even more productive – the suitable addition for the highest functionality, flexibility, reliability, and controlled production.



Miniature swivel unit



Linear module



Pick & Place Unit



Line gantry



Magnetic switches



Pressure maintenance valve



Pillar assembly system

① For more information on these products can be found on the following product pages or at [schunk.com](http://schunk.com).

## Options and special information

**Gripping force maintenance version AS:** The mechanical gripping force maintenance ensures that a minimum clamping force will be applied even in case of pressure drop. This acts as closing force in the AS version. Besides this, the gripping force maintenance can be used to increase gripping force or for single actuated gripping.

**Shock absorber version:** A shock absorber version is available for particularly damping-intensive movements. Please ask for details.

As standard, this module can be combined with numerous components from the modular system. We would be happy to assist you.

# GAP 28

Angular parallel gripper



## Gripping force O.D. gripping

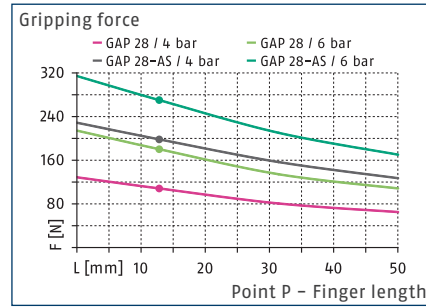

## Max. permissible inertia J\*

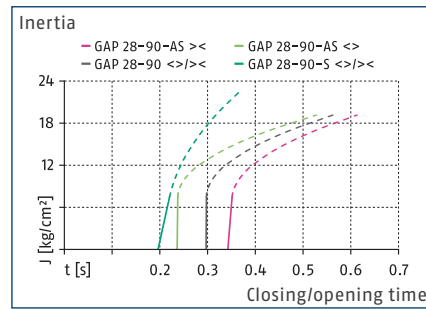

## Dimensions and maximum loads

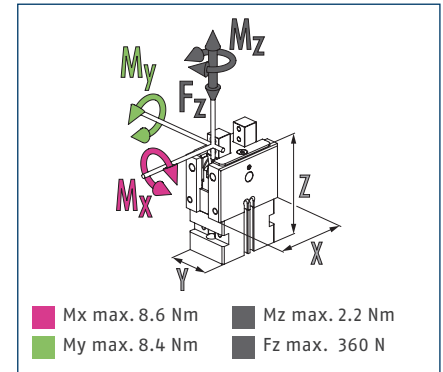

① The indicated moments and forces are static values, apply for each base jaw and may appear simultaneously. Loads may additionally occur to the moment produced by the gripping force itself.

## Technical data

Description		GAP 28-030	GAP 28-060	GAP 28-090
ID		0314610	0314611	0314612
Stroke per jaw	[mm]	1.5	1.5	1.5
Closing/opening force	[N]	180/-	180/-	180/-
Opening angle per jaw	[°]	30	60	90
Weight	[kg]	0.54	0.54	0.54
Recommended workpiece weight	[kg]	0.9	0.9	0.9
Fluid consumption double stroke	[cm³]	6.5	10.5	15
Min./nom./max. operating pressure	[bar]	3/6/7	3/6/7	3/6/7
Closing/opening time	[s]	0.17/0.17	0.23/0.23	0.3/0.3
Max. permissible finger length	[mm]	50	50	50
Max. permissible mass per finger	[kg]	0.17	0.17	0.17
Max. permissible mass moment of inertia per chuck jaw	[kgcm²]	7.45	7.45	7.45
IP protection class		40	40	40
Min./max. ambient temperature	[°C]	5/60	5/60	5/60
Repeat accuracy	[mm]	0.05	0.05	0.05
Dimensions X x Y x Z	[mm]	60 x 37 x 80.2	60 x 37 x 80.2	60 x 37 x 80.2

### Options and their characteristics

Description		GAP 28-030-AS	GAP 28-060-AS	GAP 28-090-AS
Gripping force maintenance version		GAP 28-030-AS	GAP 28-060-AS	GAP 28-090-AS
ID		0314613	0314614	0314615
Closing/opening force	[N]	270/-	270/-	270/-
Min. spring force	[N]	90	90	90
Weight	[kg]	0.7	0.7	0.7
Fluid consumption double stroke	[cm³]	9	15.5	22
Min./max. operating pressure	[bar]	4.5/6.5	4.5/6.5	4.5/6.5
Closing/opening time	[s]	0.2/0.16	0.26/0.2	0.35/0.24
Shock absorber version		GAP 28-030-S	GAP 28-060-S	GAP 28-090-S
ID		0314616	0314617	0314618
Weight	[kg]	0.58	0.58	0.58
Closing/opening time	[s]	0.13/0.13	0.15/0.15	0.2/0.2

\* The unit can be actuated without an external customized throttling at the given value of max. mass moment of inertia per jaw. In case of higher mass moments of inertia, an additional throttling is possible.

## Main view

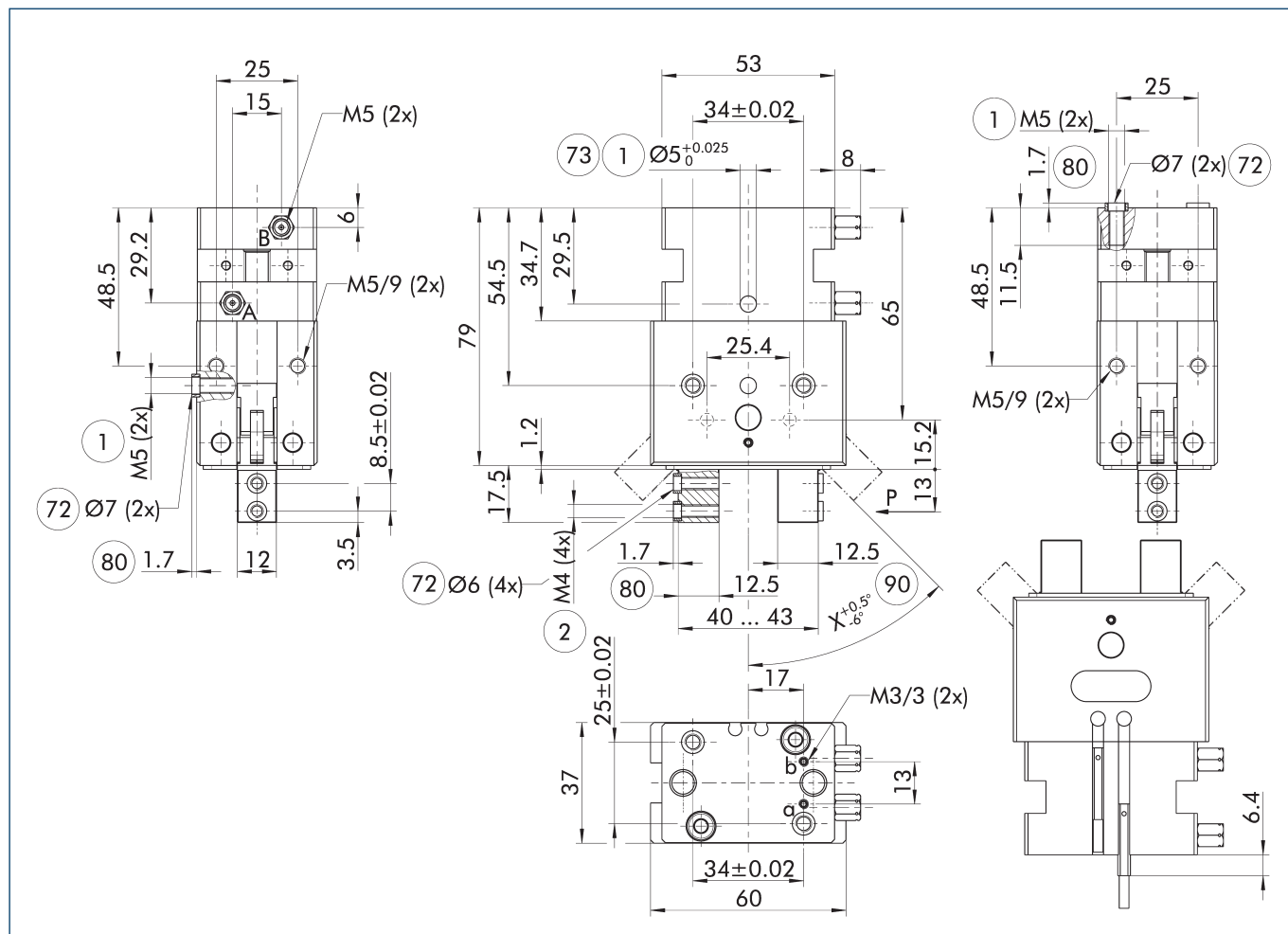

The drawing shows the gripper in the basic version with closed jaws, without dimensional consideration of the options described below.

- ① The SDV-P pressure maintenance valve can also be used for I.D. or O.D. gripping alternatively or in addition to the spring-loaded, mechanical gripping force maintenance device (see catalog section on accessories).

- A, a Main / direct connection, gripper opening
- B, b Main / direct connection, gripper closing
- ① Gripper connection
- ② Finger connection

- ⑦② Fit for centering sleeves
- ⑦③ Fit for centering pins
- ⑧① Depth of the centering sleeve hole in the counter part
- ⑨① See the technical data for "opening angle per jaw"

### Max. permissible inertia J\*

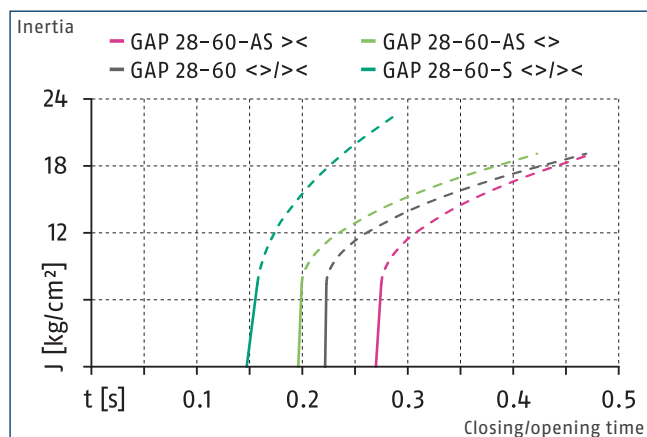

\* The unit can be actuated without an external customized throttling at the given value of max. mass moment of inertia per jaw. In case of higher mass moments of inertia, an additional throttling is possible.

### Max. permissible inertia J\*

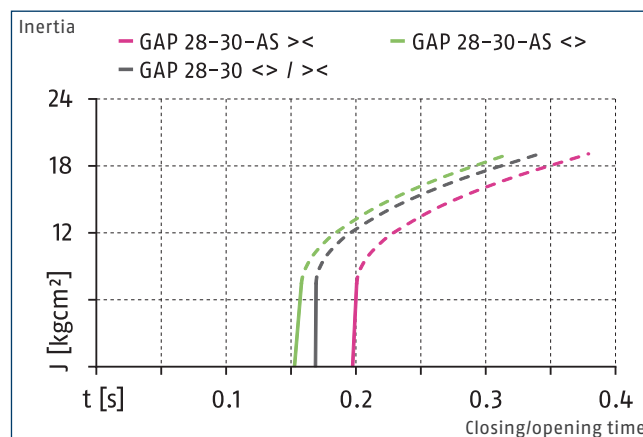

\* The unit can be actuated without an external customized throttling at the given value of max. mass moment of inertia per jaw. In case of higher mass moments of inertia, an additional throttling is possible.

# GAP 28

Angular parallel gripper

## Hose-free direct connection M3

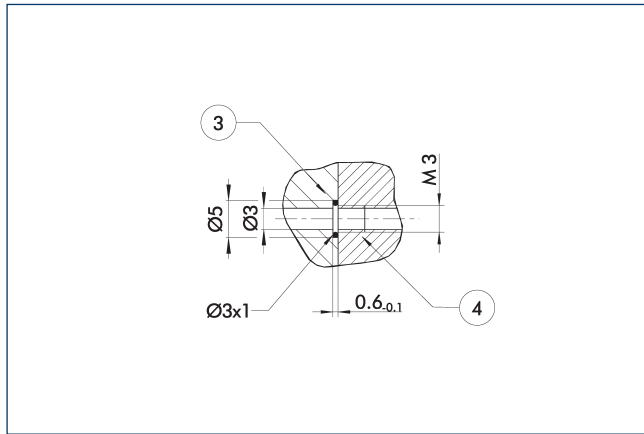

- ③ Adapter
- ④ Grippers

The direct connection is used for supplying compressed air without hoses. Instead, the pressure medium is fed through bore-holes in the mounting plate.

## Finger design

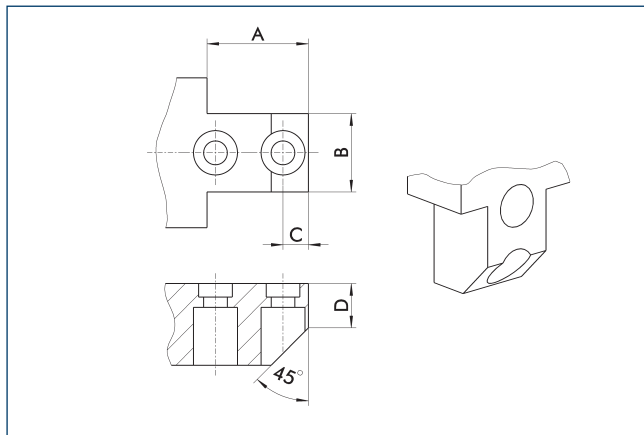

The drawing shows a suggestion of how to design the gripper fingers.

A (min.)	B (max.)	C (max.)	D
[mm]	[mm]	[mm]	[mm]
16	11.9	3.9	11

## Gripping force maintenance AS

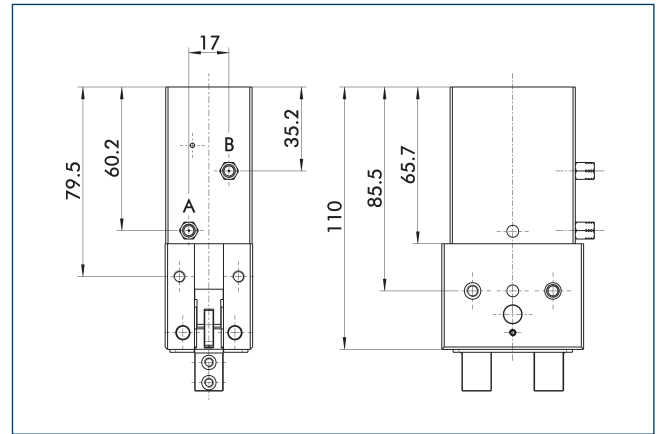

The mechanical gripping force maintenance ensures that a minimum gripping force will be applied even if there is a drop in pressure. This acts on the closing force. The gripping force maintenance can also be used to increase the gripping force or for one-way gripping.

## Version with shock absorbers

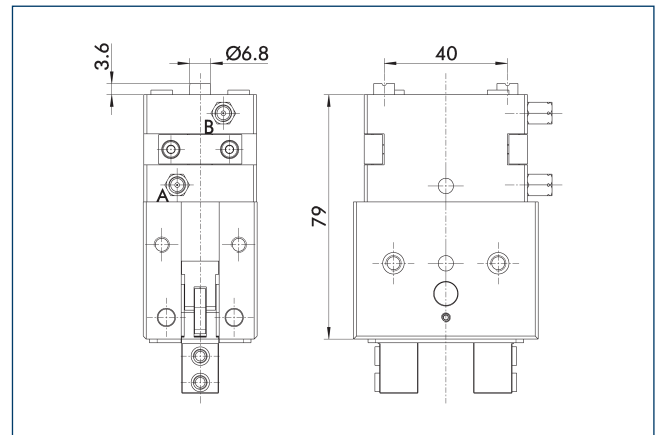

In the shock absorber variant, the opening movement of the fingers is braked via hydraulic shock absorbers. Therefore faster opening times are achieved.



## Electronic magnetic switch MMS

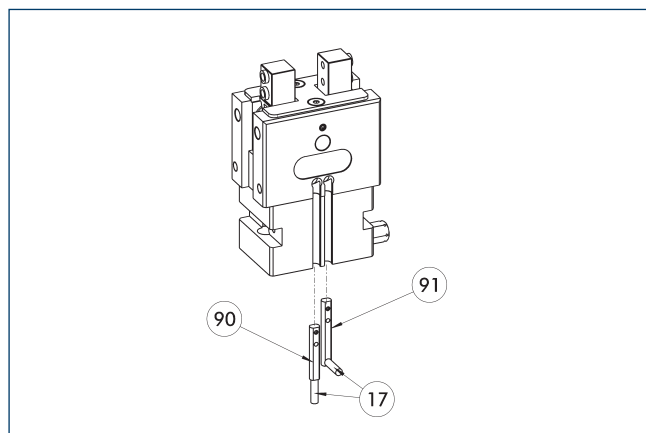

- ① Cable outlet  
 ② Sensor MMS 22...-SA  
 ③ Sensor MMS 22..

End position monitoring for mounting in the C-slot.

Description	ID	Often combined
<b>Electronic magnetic switch</b>		
MMS 22-S-M8-PNP	0301032	●
MMSK 22-S-PNP	0301034	
<b>Electronic magnetic switches with lateral cable outlet</b>		
MMS 22-S-M8-PNP-SA	0301042	●
MMSK 22-S-PNP-SA	0301044	
<b>Connection cables</b>		
KA BG08-L 3P-0300-PNP	0301622	●
KA BG08-L 3P-0500-PNP	0301623	
KA BW08-L 3P-0300-PNP	0301594	
KA BW08-L 3P-0500-PNP	0301502	
<b>clip for plug/socket</b>		
CLI-M8	0301463	
<b>Cable extension</b>		
KV BW08-SG08 3P-0030-PNP	0301495	
KV BW08-SG08 3P-0100-PNP	0301496	
KV BW08-SG08 3P-0200-PNP	0301497	●
<b>Sensor distributor</b>		
V2-M8	0301775	●
V4-M8	0301746	
V8-M8	0301751	

- ④ Two sensors are required per unit for monitoring two positions. On option, extension cables and sensor distributors are available. Additional product variants of the sensor, and further information and technical data can be found in the catalog chapter sensor system.



**SCHUNK GmbH & Co. KG**  
**Spann- und Greiftechnik**

Bahnhofstr. 106 - 134  
D-74348 Lauffen/Neckar  
Tel. +49-7133-103-0  
Fax +49-7133-103-2399  
info@de.schunk.com  
schunk.com

Folgen Sie uns | *Follow us*

