



Superior Clamping and Gripping



Product Information

Radial gripper PRG 64

PRG

Radial gripper

Flexible. Powerful. Slim.

Universal gripper PRG

180° radial gripper with powerful 1-shift slotted link gear and oval piston

Field of application

For areas of application which, in addition to a large gripping force, require the shortest possible motion sequences through the radial design of the jaw stroke.

Advantages – Your benefits

Kinematics the 1-shift slotted link gear assures a consistent closing moment from -5° to $+7^\circ$.

Optimized cycle time due to innovative damping directly integrated drive chain

Maximum compact performance for higher closing moments, longer and stable gripper fingers

Many options ensure a higher degree of flexibility adjusted to the individual application, the PRG is also available with a mechanic gripping force maintenance, as a high-temperature version, and with three opening angle versions $30^\circ/60^\circ/90^\circ$.

Air supply via hose-free direct connection or screw connections for flexible pressure supply in all automated systems



Sizes
Quantity: 8



Weight
0.13 .. 6.72 kg



Gripping moment
2 .. 265 Nm



Angle per jaw
30 .. 90°



Workpiece weight
0.3 .. 6.96 kg

Functional description

The patented "1-pin link guide" converts the movement into a powerful closing torque. The closing moment is additionally reinforced by the curved shape of the guidance.

In addition to a rapid stroke behaviour the slotted link also assures a nearly constant closing torque over a large closing angle range.

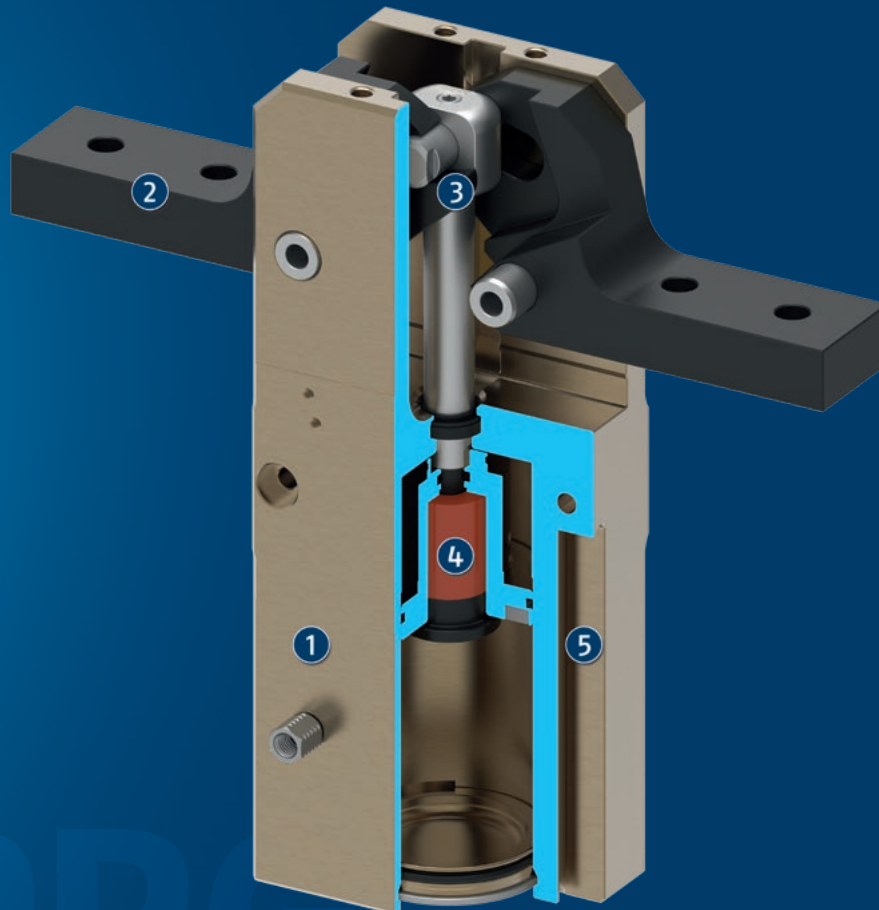

- ① **Housing**
is weight-optimized due to the use of high-strength aluminum alloy
- ② **Base Jaw**
for the connection of workpiece-specific gripper fingers
- ③ **Kinematics**
Slotted link gear for very high gripping forces when the workpiece is contacted
- ④ **Damping**
decouples the drive, for shorter cycle times
- ⑤ **Monitoring**
integrated end position monitoring with magnetic switches

General notes about the series

Operating principle: Slotted link gear

Housing material: Aluminum alloy, anodized

Base jaw material: Steel

Actuation: pneumatic, with filtered compressed air as per ISO 8573-1:2010 [7:4:4].

Warranty: 24 months

Scope of delivery: Centering sleeves, O-rings for direct connection, assembly instructions (operating manual with declaration of incorporation is available online)

Gripping force maintenance device: possible by using the version with mechanical gripping force maintenance or pressure maintenance valve SDV-P

Closing moment: is the arithmetic sum of the individual moment applied to each jaw.

The indicated closing moment will be reached at an opening angle of 0°. A detailed closing moment course depending on the opening angle can be taken out of the diagram "closing moment course".

Finger length: is measured from the reference surface as the distance P in direction to the main axis.

Repeat accuracy: is defined as a distribution of the end Position for 100 consecutive strokes.

Workpiece weight: is calculated for force-fit gripping with a coefficient of static friction of 0.1 and a safety factor of 2 against workpiece slippage at acceleration due to gravity g. For form-fit or capture gripping, there are significantly higher permissible workpiece weights.

Closing and opening times: are purely the times that the base jaws or fingers are in motion. Valve switching times, hose fill times, or PLC reaction times are not included, and are to be considered when cycle times are calculated.

Application example

Gripper swivel combination for handling of small shafts. The 180° opening angle of the gripper replaces a stroke unit which otherwise would be necessary.

- ① 2-finger radial gripper PRG
- ② Rotary actuator SRU-plus
- ③ Universal linear module Beta



SCHUNK offers more ...

The following components make the product even more productive – the suitable addition for the highest functionality, flexibility, reliability, and controlled production.

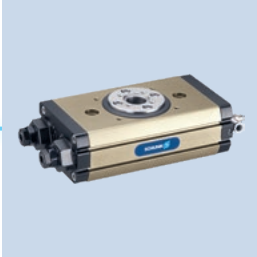

Universal swivel unit



Linear module



Quick change system



Rotary feed-through



Inductive proximity switches



Magnetic switches



Programmable magnetic switch



Pressure maintenance valve

① For more information on these products can be found on the following product pages or at schunk.com.

Options and special information

180° radial grippers are advantageous since further stroke motions are no more necessary. Since every jaw swivels away by 90°, the gripper is outside of the working area, and a stroke motion back of the whole gripper is no more necessary.

Gripping force maintenance version AS/IS: The mechanical gripping force maintenance version ensures minimum gripping force even in the event of a pressure drop. In the AS/S version this acts as a closing force, in the IS version as an opening force.

High-temperature version VHT: for use in hot environments

Additional versions: Various options can be combined with each other. Numerous additional options are also available – just tell us what your task is!



Gripping force O.D. gripping

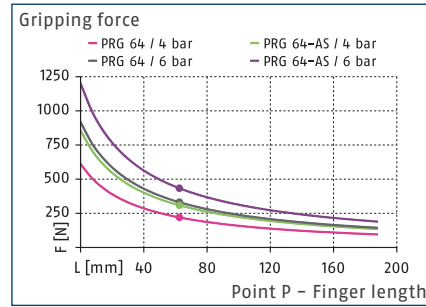

Max. permissible inertia J*

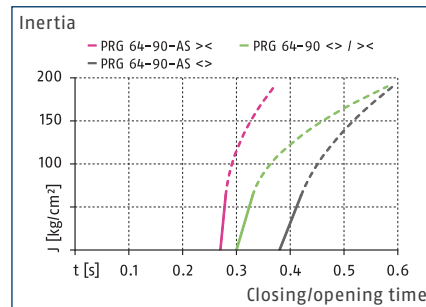

Dimensions and maximum loads

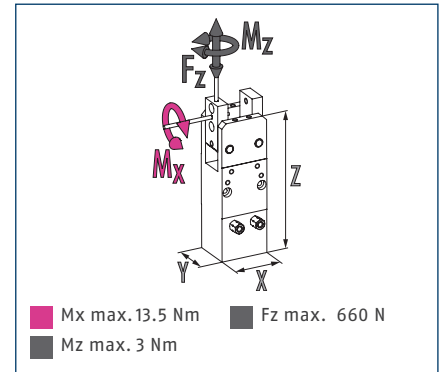

① The indicated torques and forces are static values, apply for each base jaw, and may occur simultaneously.

Technical data

Description		PRG 64-30	PRG 64-30-AS	PRG 64-60	PRG 64-60-AS	PRG 64-90	PRG 64-90-AS
ID		0303655	0303665	0303695	0303705	0303675	0303685
Opening angle per jaw	[°]	30	30	60	60	90	90
Closed angle per jaw	[°]	3	3	3	3	3	3
Closing moment	[Nm]	32.5	42.5	32.5	42.5	32.5	42.5
Closing moment generated by spring	[Nm]		10		10		10
Weight	[kg]	1.35	1.42	1.34	1.41	1.33	1.4
Recommended workpiece weight	[kg]	1.69	1.69	1.69	1.69	1.69	1.69
Fluid consumption double stroke	[cm³]	88	88	102	102	120	120
Min./nom./max. operating pressure	[bar]	2/6/8	4/6/6.5	2/6/8	4/6/6.5	2/6/8	4/6/6.5
Closing/opening time	[s]	0.22/0.22	0.21/0.29	0.3/0.3	0.27/0.38	0.38/0.38	0.37/0.47
Closing time with spring only	[s]		0.14		0.28		0.42
Max. permissible finger length	[mm]	125	125	125	125	125	125
Max. permissible mass moment of inertia per chuck jaw	[kgcm²]	63.37	63.37	63.37	63.37	63.37	63.37
IP protection class		20	20	20	20	20	20
Min./max. ambient temperature	[°C]	5/90	5/90	5/90	5/90	5/90	5/90
Repeat accuracy	[mm]	0.05	0.05	0.05	0.05	0.05	0.05
Dimensions X x Y x Z	[mm]	64 x 42 x 170	64 x 42 x 170	64 x 42 x 170	64 x 42 x 170	64 x 42 x 170	64 x 42 x 170
Options and their characteristics							
High-temperature version		39303655	39303665	39303695	39303705	39303675	39303685
Min./max. ambient temperature	[°C]	5/130	5/130	5/130	5/130	5/130	5/130

* The unit can be actuated without an external customized throttling at the given value of max. mass moment of inertia per jaw. In case of higher mass moments of inertia, an additional throttling is possible.
 The curve applies for 90° versions. For other versions the curve must be parallelly off-set according to the opening and closing times.

Main view

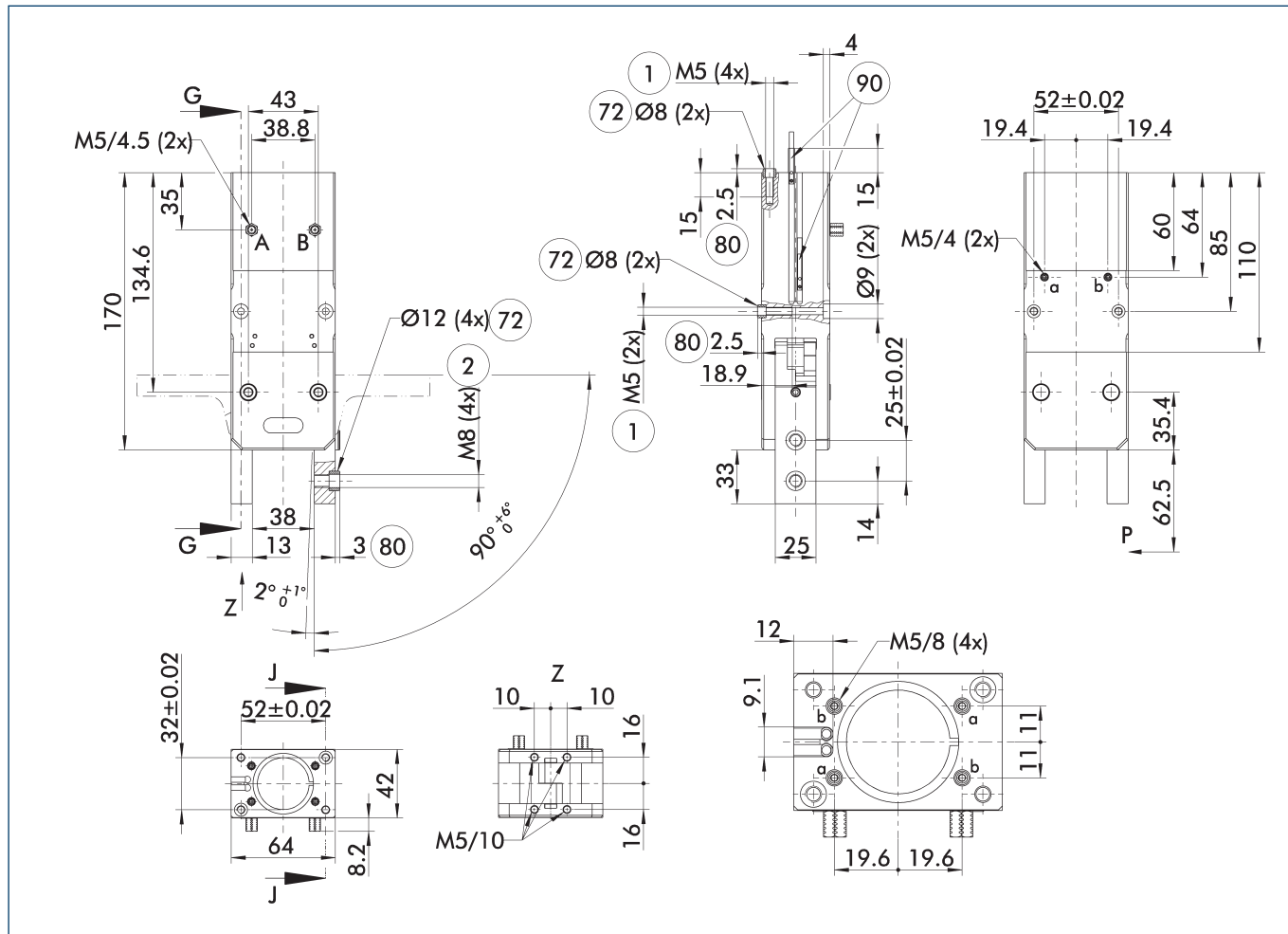

The drawing shows the gripper in the basic version with closed jaws, without dimensional consideration of the options described below.

① The SDV-P pressure maintenance valve can also be used for I.D. or O.D. gripping alternatively or in addition to the spring-loaded, mechanical gripping force maintenance device (see catalog section on accessories).

- A, a Main / direct connection, gripper opening
- B, b Main / direct connection, gripper closing
- ① Gripper connection
- ② Finger connection
- 72 Fit for centering sleeves
- 80 Depth of the centering sleeve hole in the counter part
- 90 Sensor MMS 22..

Closing torque curve**

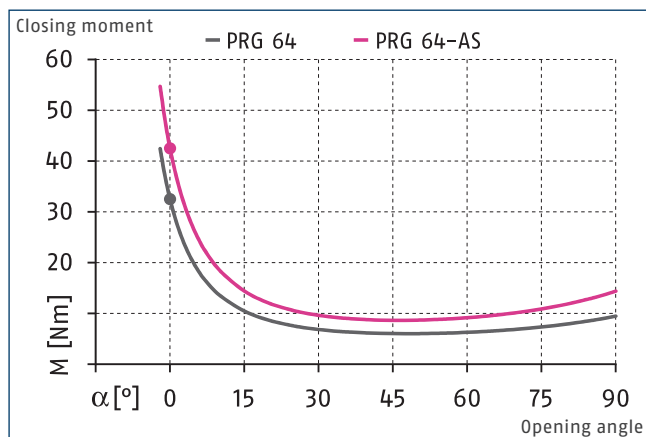

** The diagram is valid for all opening angle variants.

PRG 64

Radial gripper

Maximum permitted finger projection

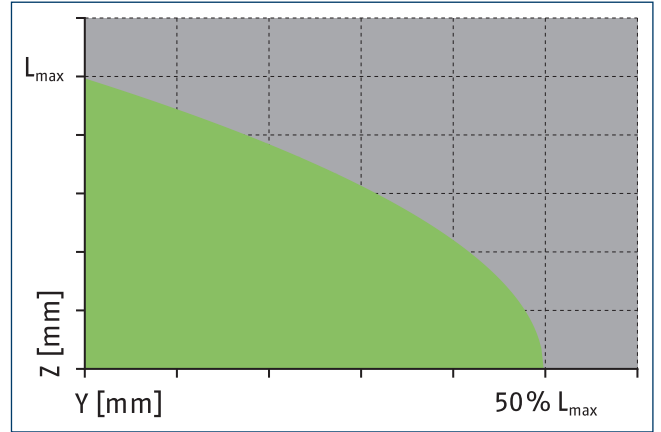
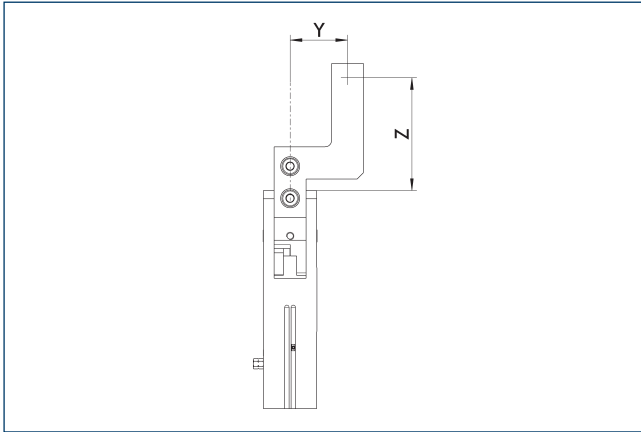

■ Permitted range ■ Inadmissible range

L_{max} is equivalent to the maximum permitted finger length, see the technical data table.

Hose-free direct connection M5

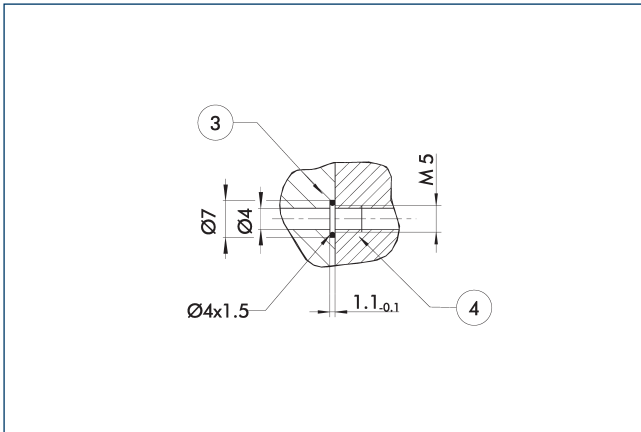

③ Adapter

④ Grippers

The direct connection is used for supplying compressed air without hoses. Instead, the pressure medium is fed through bore-holes in the mounting plate.

Finger design

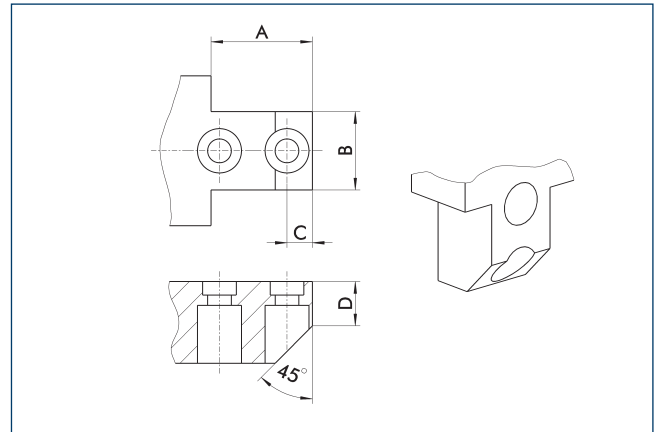

The drawing shows a suggestion of how to design the gripper fingers.

A	B	C	D
[mm]	[mm]	[mm]	[mm]
24	24.5	15	18

SDV-P pressure maintenance valve

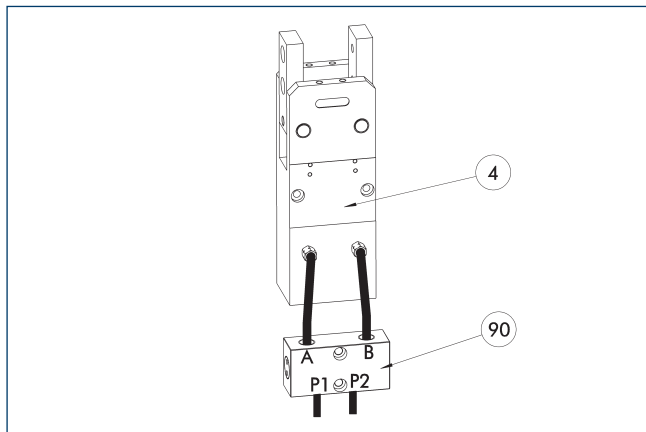

④ Grippers

⑨⑩ SDV-P pressure maintenance valve

The SDV-P pressure maintenance valve ensures in emergency STOP situations that the pressure in the piston chamber of pneumatic gripper, swivel, linear, and quick-change modules is temporarily maintained.

Description	ID	Recommended hose diameter [mm]
Pressure maintenance valve		
SDV-P 04	0403130	6
Pressure maintenance valve with air bleed screw		
SDV-P 04-E	0300120	6

① In order to achieve the specified closing and opening time for each gripper variant, the recommended hose diameter must be used. The direct allocation of the respective variant of the gripper for the respective SDV-P can be found at schunk.com.

IN 40 inductive proximity switches

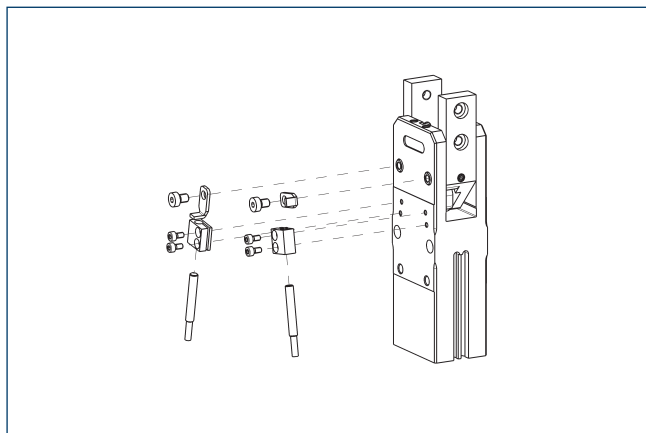

End position monitoring can be mounted with an attachment kit.

Description	ID	Often combined
Attachment kit for proximity switch		
AS-PRG 64-IN40	0303625	
Inductive proximity switches		
IN 40-S-M12	0301574	
IN 40-S-M8	0301474	●
INK 40-S	0301555	

① Two sensors (closer/S) are required for each unit and extension cables are available as an option. This attachment kit needs to be ordered optionally as an accessory. For sensor cables, note the minimum permissible bending radii. These are generally 35 mm.

Attachment kit for proximity switch IN 40

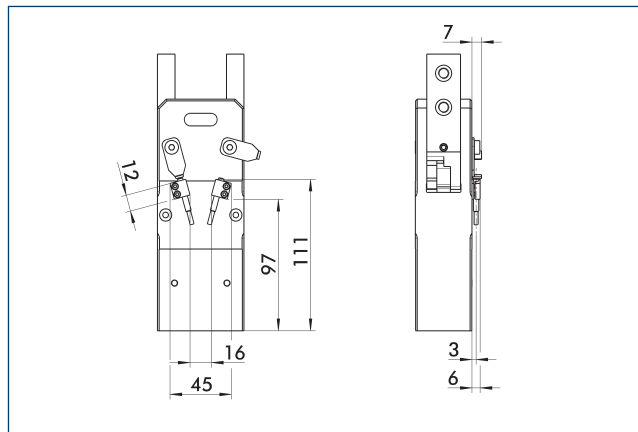

The attachment kit consists of brackets, control cams, and appropriate fastening materials. The proximity switches must be ordered separately.

Description	ID
Attachment kit for proximity switch	
AS-PRG 64-IN40	0303625

① This attachment kit needs to be ordered optionally as an accessory.

Attachment kit for proximity switch IN 80

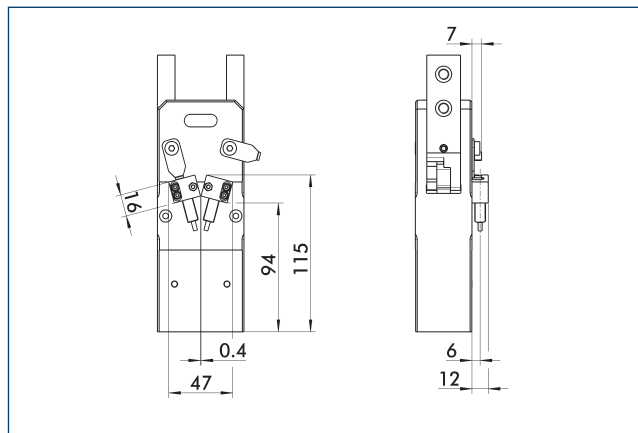

The attachment kit consists of brackets, control cams, and appropriate fastening materials. The proximity switches must be ordered separately.

Description	ID
Attachment kit for proximity switch	
AS-PRG 64-IN80	0304136

① This attachment kit needs to be ordered optionally as an accessory.

IN 80 inductive proximity switches

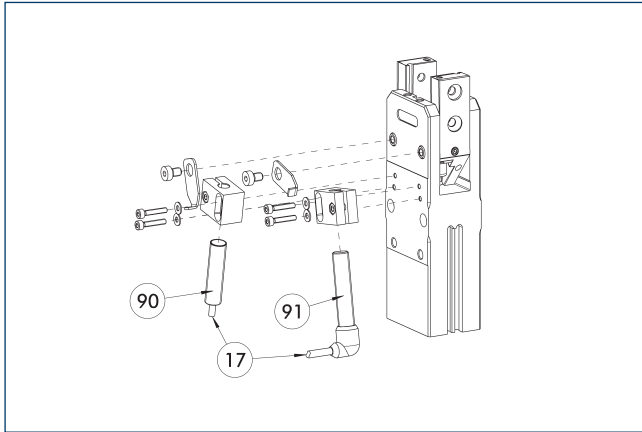

- 17 Cable outlet
- 91 Sensor IN..-SA
- 90 Sensor IN ...

End position monitoring can be mounted with an attachment kit.

Description	ID	Often combined
Attachment kit for proximity switch		
AS-PRG 64-IN80	0304136	
Inductive proximity switches		
IN 80-S-M12	0301578	
IN 80-S-M8	0301478	●
INK 80-S	0301550	

- ① Two sensors (closer/S) are required for each unit and extension cables are available as an option. This attachment kit needs to be ordered optionally as an accessory. For sensor cables, note the minimum permissible bending radii. These are generally 35 mm.

Electronic magnetic switch MMS

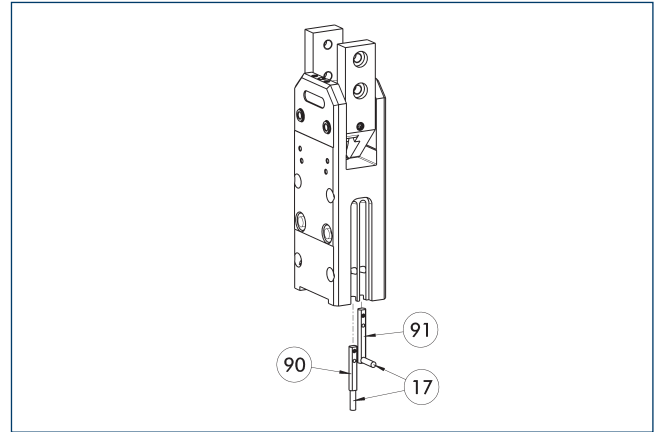

- 17 Cable outlet
- 91 Sensor MMS 22...-SA
- 90 Sensor MMS 22..

End position monitoring for mounting in the C-slot.

Description	ID	Often combined
Electronic magnetic switch		
MMS 22-S-M8-PNP	0301032	●
MMSK 22-S-PNP	0301034	
Electronic magnetic switches with lateral cable outlet		
MMS 22-S-M8-PNP-SA	0301042	●
MMSK 22-S-PNP-SA	0301044	
Reed Switches		
RMS 22-S-M8	0377720	●
Connection cables		
KA BG08-L 3P-0300-PNP	0301622	●
KA BG08-L 3P-0500-PNP	0301623	
KA BW08-L 3P-0300-PNP	0301594	
KA BW08-L 3P-0500-PNP	0301502	
clip for plug/socket		
CLI-M8	0301463	
Wireless sensor system		
RSS-T2	0377715	
RSS-T2-US/CA	0377717	
Cable extension		
KV BW08-SG08 3P-0030-PNP	0301495	
KV BW08-SG08 3P-0100-PNP	0301496	
KV BW08-SG08 3P-0200-PNP	0301497	●
Sensor distributor		
V2-M8	0301775	●
V4-M8	0301746	
V8-M8	0301751	

- ① Two sensors are required per unit for monitoring two positions. On option, extension cables and sensor distributors are available. Additional product variants of the sensor, and further information and technical data can be found in the catalog chapter sensor system.

Programmable magnetic switch MMS 22-PI1

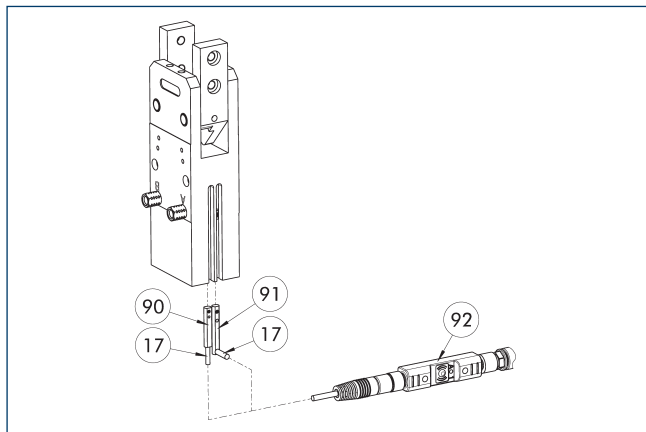

- ①⑦ Cable outlet
- ①⑨ Sensor MMS 22 ..-PI1-...-SA
- ①⑩ Sensor MMS 22 PI1-...
- ①⑫ Connector teaching tool ST

Position monitoring with one programmable switching point per sensor, directly mountable in the C-slot. The electronics are built into the sensor. The cable outlet can be located either axially or laterally (MMS 22...-SA). Programmed using the plug teaching tool ST (to be ordered separately).

Description	ID	Often combined
Programmable magnetic switch		
MMS 22-PI1-S-M8-PNP	0301160	●
MMSK 22-PI1-S-PNP	0301162	
Programmable magnetic switch with lateral cable outlet		
MMS 22-PI1-S-M8-PNP-SA	0301166	●
MMSK 22-PI1-S-PNP-SA	0301168	
Programmable magnetic switch with stainless steel housing		
MMS 22-PI1-S-M8-PNP-HD	0301110	●
MMSK 22-PI1-S-PNP-HD	0301112	
Plug teaching tool		
ST-MMS 22-PI1-PNP	0301025	

- ① Two sensors (closer/S) are required for each unit and extension cables are available as an option.

Programmable magnetic switch MMS 22-PI2

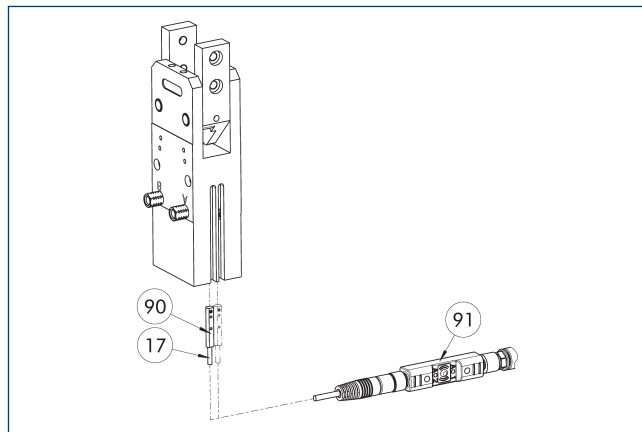

- ①⑦ Cable outlet
- ①⑨ Connector teaching tool ST
- ①⑩ MMS 22...-PI2-... sensor

Position monitoring with two programmable switching points per sensor, mountable directly in the C-slot. The electronics are built into the sensor. Programmed using the plug teaching tool ST (to be ordered separately).

Description	ID	Often combined
Programmable magnetic switch		
MMS 22-PI2-S-M8-PNP	0301180	●
MMSK 22-PI2-S-PNP	0301182	
Programmable magnetic switch with lateral cable outlet		
MMS 22-PI2-S-M8-PNP-SA	0301186	●
MMSK 22-PI2-S-PNP-SA	0301188	
Programmable magnetic switch with stainless steel housing		
MMS 22-PI2-S-M8-PNP-HD	0301130	●
MMSK 22-PI2-S-PNP-HD	0301132	
Plug teaching tool		
ST-MMS 22-PI2-PNP	0301026	

- ① Per unit, at least one sensor (closer/S) and an optional cable extension are required. A maximum of one sensor per C-slot or sensor bracket can be mounted.

MMS-P programmable magnetic switch

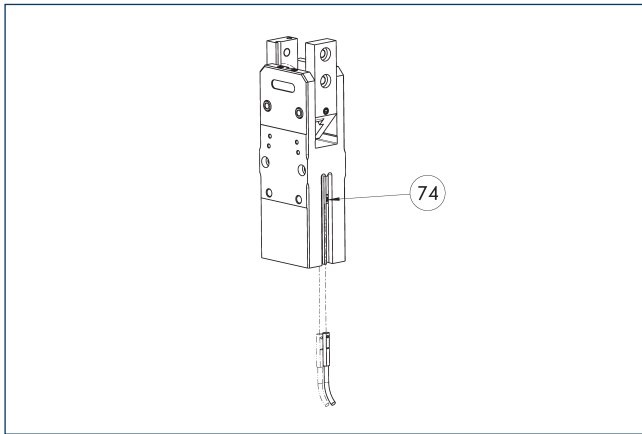

74 Limit stop for sensor

Position monitoring with two programmable positions per sensor. End position monitoring for mounting in the C-slot.

Description	ID	Often combined
Programmable magnetic switch		
MMSK-P 22-S-PNP	0301371	
MMS-P 22-S-M8-PNP	0301370	●
Connection cables		
KA GLN0804-LK-00500-A	0307767	●
KA GLN0804-LK-01000-A	0307768	
KA WLN0804-LK-00500-A	0307765	
KA WLN0804-LK-01000-A	0307766	
clip for plug/socket		
CLI-M8	0301463	
Sensor distributor		
V2-M8-4P-2XM8-3P	0301380	

① One sensor is required per unit for monitoring two positions. Extension cables and sensor distributors are optionally available. Additional product variants of the sensor, and further information and technical data can be found in the catalog chapter sensor systems.



SCHUNK GmbH & Co. KG
Spann- und Greiftechnik

Bahnhofstr. 106 - 134
D-74348 Lauffen/Neckar
Tel. +49-7133-103-0
Fax +49-7133-103-2399
info@de.schunk.com
schunk.com

Folgen Sie uns | *Follow us*

