



Superior Clamping and Gripping



Product Information

Angular gripper SGB

SGB

Angular gripper

Light. Slim. Fast.

Gripper for small components SGB

Small, simple pressurized plastic angular gripper with spring return

Field of application

Universal application in clean and slightly dirty environments, with special requirements on corrosion resistance and anti-static properties of the gripping unit

Advantages – Your benefits

Housing made from glass fiber reinforced plastic Making the gripper extremely light and free from corrosion

One-way acting double piston drive with lever gear drive for high power transmission and synchronized gripping

Basic version generally equipped with a pressure piece for the spring-supported pressing of workpieces

favorable in price especially suitable for low-budget applications



Sizes
Quantity: 3



Weight
0.04 .. 0.06 kg



Gripping moment
0.9 .. 4.95 Nm



Angle per jaw
8°



Workpiece weight
0.2 .. 0.8 kg

Functional description

The horizontally arranged pistons are pressed away from each other by compressed air.

The base jaws are opened at an angle and in a synchronized fashion by the bearing-mounted lever mechanism.

Reset is done by compression spring.

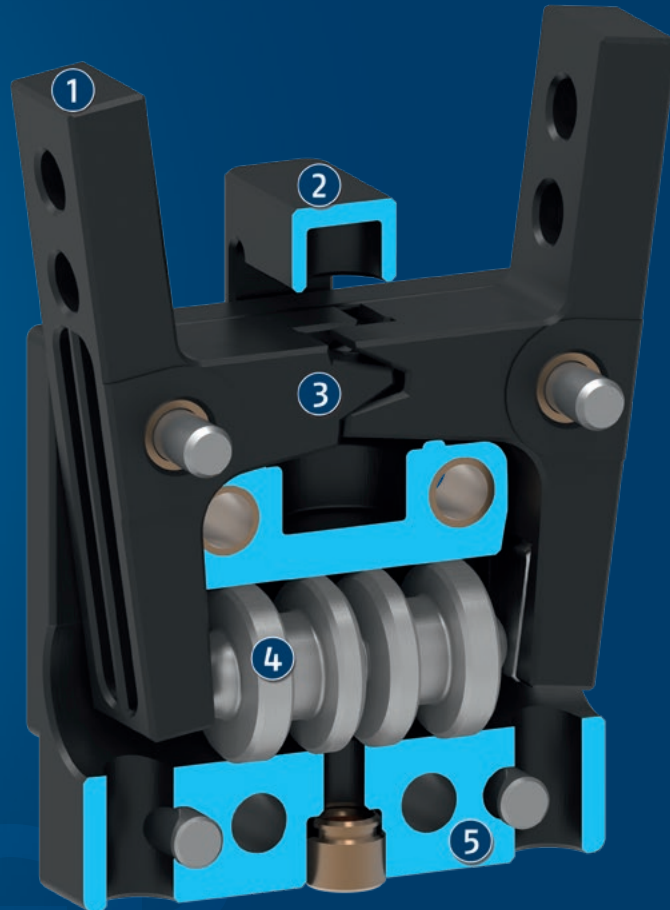

- ① **Base Jaw**
for the connection of workpiece-specific gripper fingers
- ② **Pressure piece**
spring-loaded, for pressing workpieces into place
- ③ **Lever mechanism**
for precise and synchronized gripping
- ④ **Drive**
single-acting double piston system with spring return
- ⑤ **Housing**
weight-optimized due to the use of plastics

General notes about the series

Operating principle: single-acting cylinder piston with lever gear drive and spring reset

Housing material: Plastic with metal functional components

Base jaw material: Plastic

Actuation: pneumatic, with filtered compressed air as per ISO 8573-1:2010 [7:4:4].

Warranty: 24 months

Scope of delivery: integrated spring-loaded press-on bar, assembly instructions (operating manual with declaration of incorporation available online)

Gripping force maintenance device: not possible

Closing moment: is the arithmetic sum of the individual moment applied to each jaw.

Finger length: is measured from the reference surface as the distance P in direction to the main axis.

Repeat accuracy: is defined as a distribution of the end Position for 100 consecutive strokes.

Workpiece weight: is calculated for force-fit gripping with a coefficient of static friction of 0.1 and a safety factor of 2 against workpiece slippage at acceleration due to gravity g. For form-fit or capture gripping, there are significantly higher permissible workpiece weights.

Closing and opening times: are purely the times that the base jaws or fingers are in motion. Valve switching times, hose fill times, or PLC reaction times are not included, and are to be considered when cycle times are calculated.



Application example

Rotary unit for simultaneous rotation of two small components by 90°

① 2-finger angular gripper SGB

② Miniature swivel unit SRU-mini

SCHUNK offers more ...

The following components make the product even more productive – the suitable addition for the highest functionality, flexibility, reliability, and controlled production.



Miniature swivel unit



Linear module



Manual change system



Pressure maintenance valve



Inductive proximity switches

① For more information on these products can be found on the following product pages or at schunk.com.

Options and special information

Due to the use of plastics, this gripper is characterized by a low weight.

SGB 32

Angular gripper



Gripping force O.D. gripping

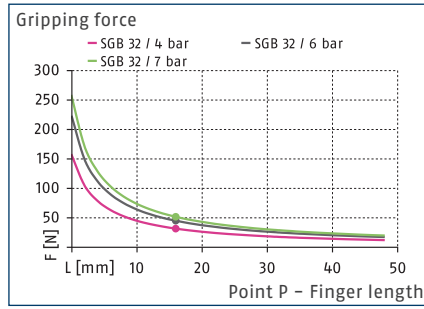

Closing moment curve

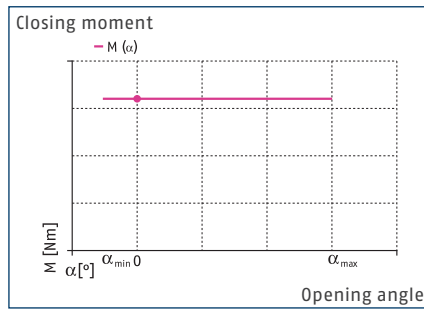

Dimensions and maximum loads

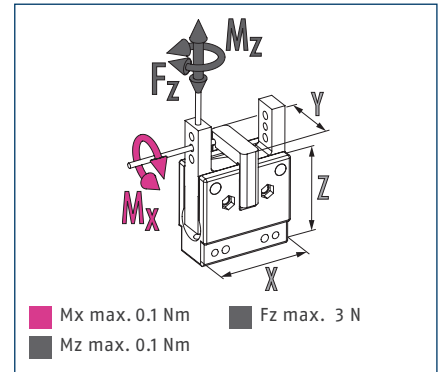

① The indicated torques and forces are static values, apply for each base jaw, and may occur simultaneously.

Technical data

Description		SGB 32
ID		0305199
Opening angle per jaw	[°]	8
Closed angle per jaw up to	[°]	2
Closing moment	[Nm]	0.9
Weight	[kg]	0.04
Recommended workpiece weight	[kg]	0.2
Fluid consumption double stroke	[cm ³]	0.5
Min./nom./max. operating pressure	[bar]	4/6/7
Closing/opening time	[s]	0.06/0.04
Max. permissible finger length	[mm]	32
Max. permissible mass per finger	[kg]	0.03
IP protection class		20
Min./max. ambient temperature	[°C]	5/90
Repeat accuracy	[mm]	0.1
Min. pressing on force	[N]	2
Pressure stroke	[mm]	3.2
Dimensions X x Y x Z	[mm]	32 x 20 x 32

Main view

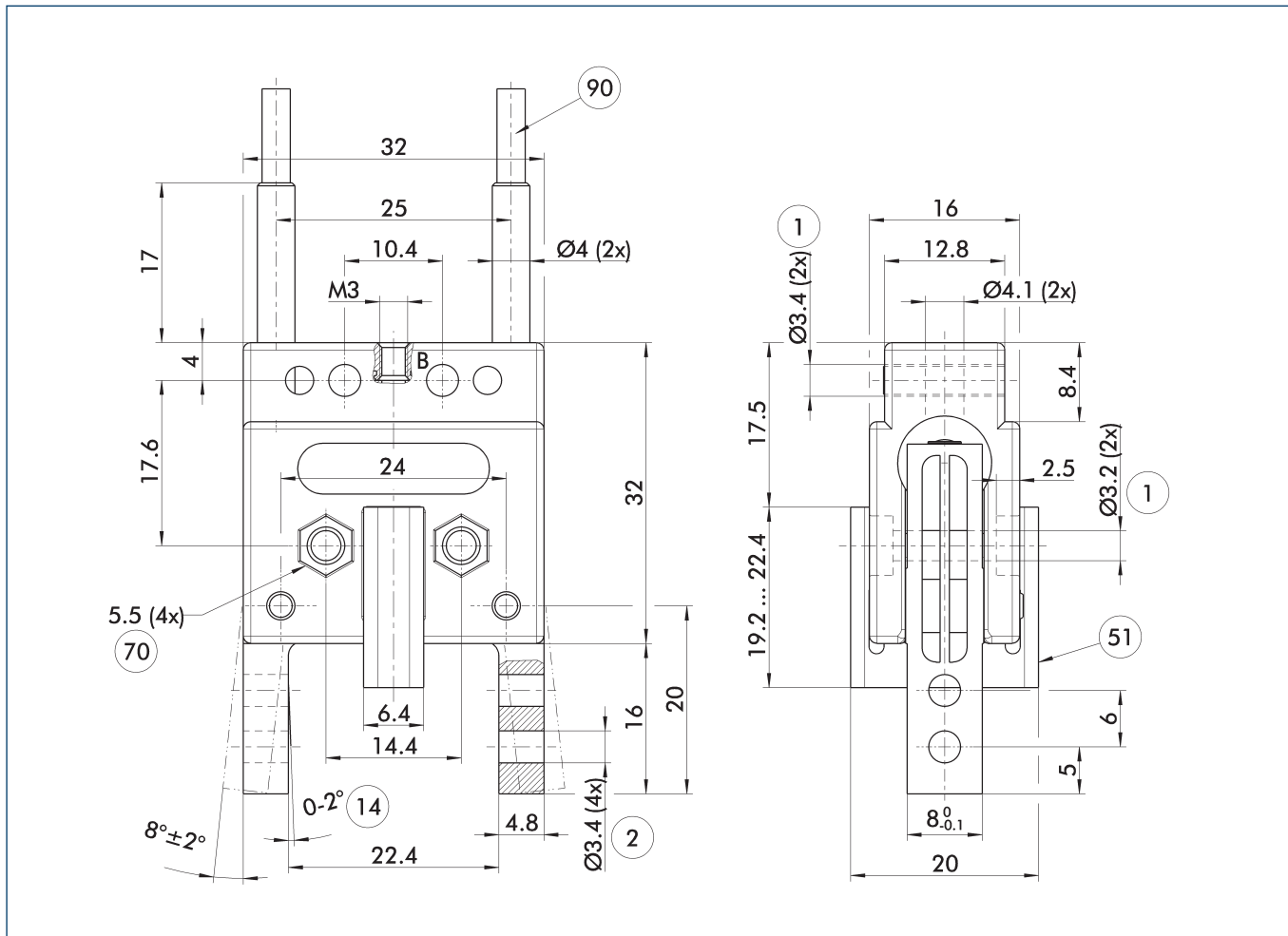

The drawing shows the gripper in the basic version with closed jaws, without dimensional consideration of the options described below.

① The SDV-P pressure maintenance valve can be used as a gripping force maintenance device (see catalog section on accessories).

B, b Main / direct connection, gripper closing

① Gripper connection
② Finger connection

⑭ Clamping reserve per finger

⑤① Pressure piece
⑦⑦ Wrench size
⑨⑨ Sensor IN ...

Mounting

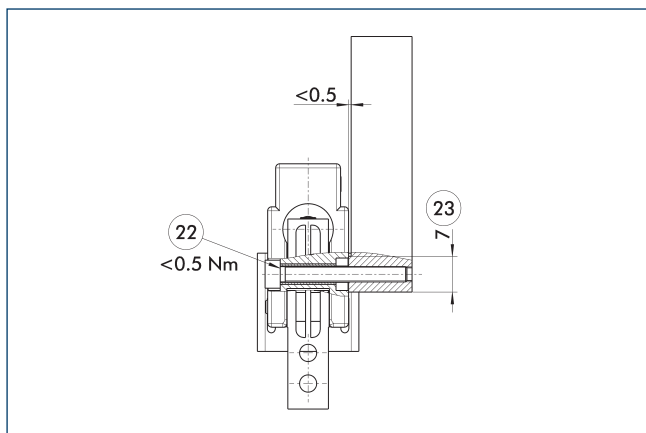

②② Tightening torque

②③ Width of path

Recommended for achieving distortion-free gripper mounting.

Inductive Proximity Switches

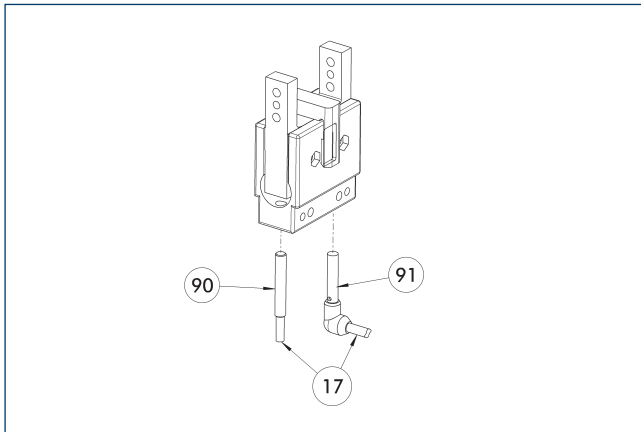

17 Cable outlet

91 Sensor IN..-SA

90 Sensor IN ...

Directly mounted end position monitoring.

Description	ID	Often combined
Inductive proximity switches		
IN 40-0-M12	0301584	
IN 40-0-M8	0301484	●
IN 40-S-M12	0301574	
IN 40-S-M8	0301474	●
INK 40-0	0301556	
INK 40-S	0301555	
Inductive proximity switch with lateral cable outlet		
IN 40-S-M12-SA	0301577	
IN 40-S-M8-SA	0301473	●
INK 40-S-SA	0301565	
Connection cables		
KA BG08-L 3P-0300-PNP	0301622	●
KA BG08-L 3P-0500-PNP	0301623	
KA BG12-L 3P-0500-PNP	30016369	
KA BW08-L 3P-0300-PNP	0301594	
KA BW08-L 3P-0500-PNP	0301502	
KA BW12-L 3P-0300-PNP	0301503	
KA BW12-L 3P-0500-PNP	0301507	
clip for plug/socket		
CLI-M12	0301464	
CLI-M8	0301463	
Cable extension		
KV BG12-SG12 3P-0030-PNP	0301999	
KV BG12-SG12 3P-0060-PNP	0301998	
KV BW08-SG08 3P-0030-PNP	0301495	
KV BW08-SG08 3P-0100-PNP	0301496	
KV BW08-SG08 3P-0200-PNP	0301497	●
KV BW12-SG12 3P-0030-PNP	0301595	
KV BW12-SG12 3P-0100-PNP	0301596	
KV BW12-SG12 3P-0200-PNP	0301597	
Sensor distributor		
V2-M12	0301776	●
V2-M8	0301775	●
V4-M8	0301746	
V8-M8	0301751	

① Two sensors are required per unit, one normally open (S) and one normally closed (O), as well as an optionally available extension cable.

SGB 40

Angular gripper



Gripping force O.D. gripping

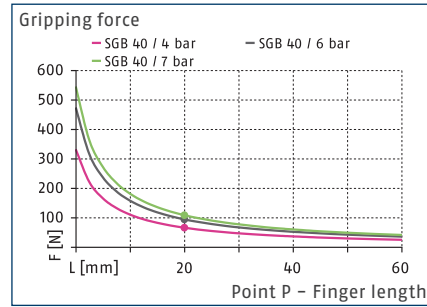

Closing moment curve

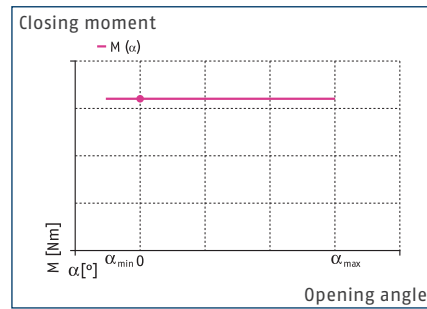

Dimensions and maximum loads

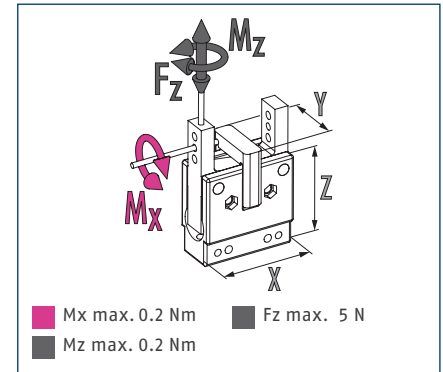

① The indicated torques and forces are static values, apply for each base jaw, and may occur simultaneously.

Technical data

Description		SGB 40
ID		0305200
Opening angle per jaw	[°]	8
Closed angle per jaw up to	[°]	2
Closing moment	[Nm]	2.37
Weight	[kg]	0.05
Recommended workpiece weight	[kg]	0.4
Fluid consumption double stroke	[cm ³]	1
Min./nom./max. operating pressure	[bar]	4/6/7
Closing/opening time	[s]	0.08/0.05
Max. permissible finger length	[mm]	40
Max. permissible mass per finger	[kg]	0.05
IP protection class		20
Min./max. ambient temperature	[°C]	5/90
Repeat accuracy	[mm]	0.1
Min. pressing on force	[N]	4
Pressure stroke	[mm]	4
Dimensions X x Y x Z	[mm]	40 x 25 x 40

Main view

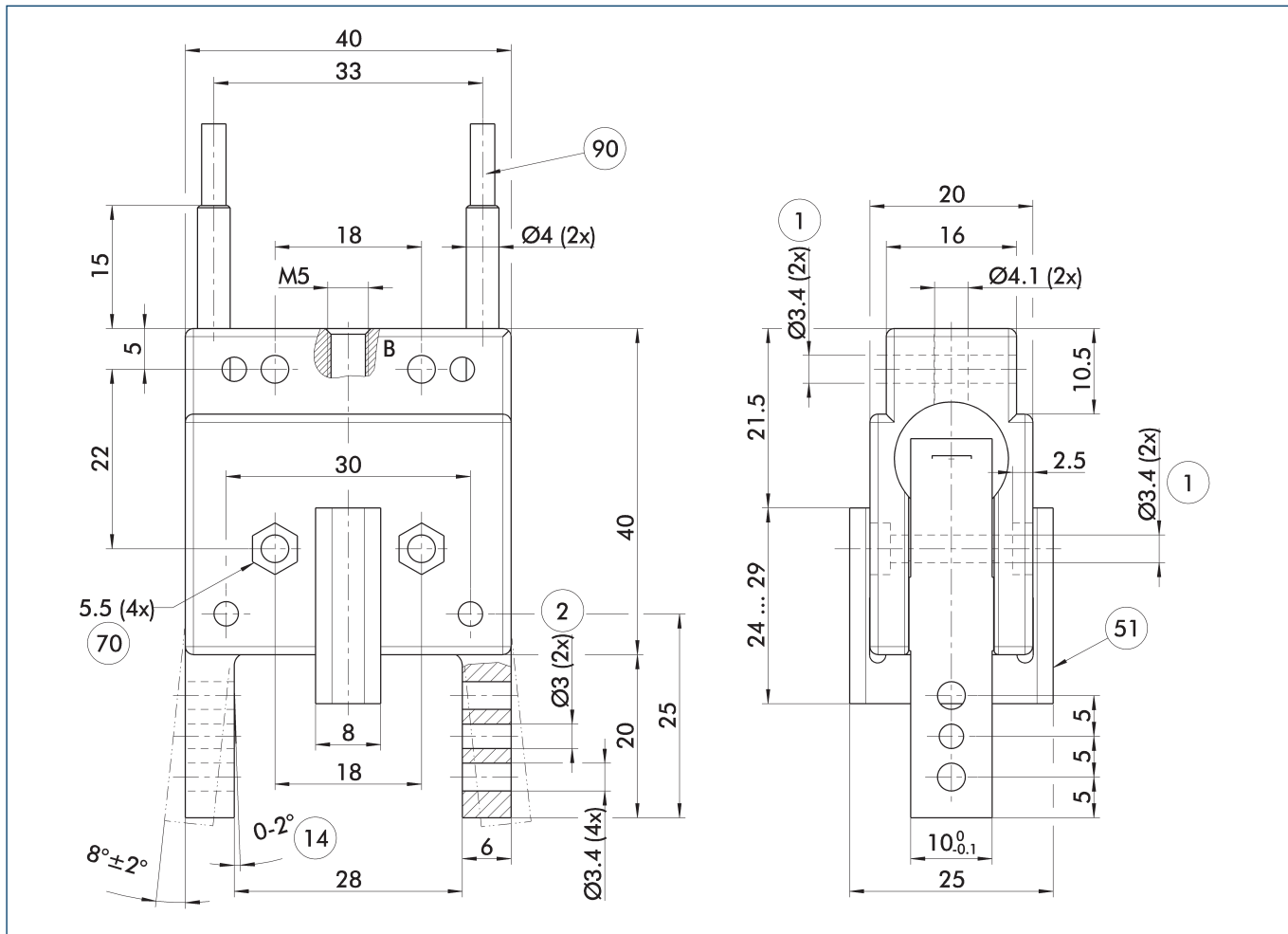

The drawing shows the gripper in the basic version with closed jaws, without dimensional consideration of the options described below.

① The SDV-P pressure maintenance valve can be used as a gripping force maintenance device (see catalog section on accessories).

B, b Main / direct connection, gripper closing

① Gripper connection
② Finger connection

⑭ Clamping reserve per finger

⑤① Pressure piece
⑦⑦ Wrench size
⑨⑨ Sensor IN ...

Mounting

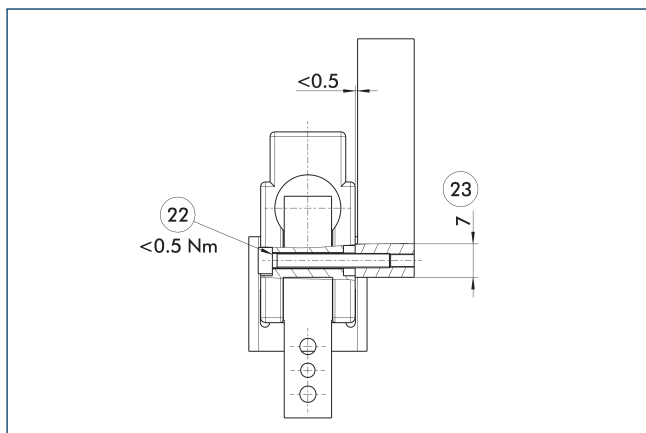

②② Tightening torque

②③ Width of path

Recommended for achieving distortion-free gripper mounting.

Inductive Proximity Switches

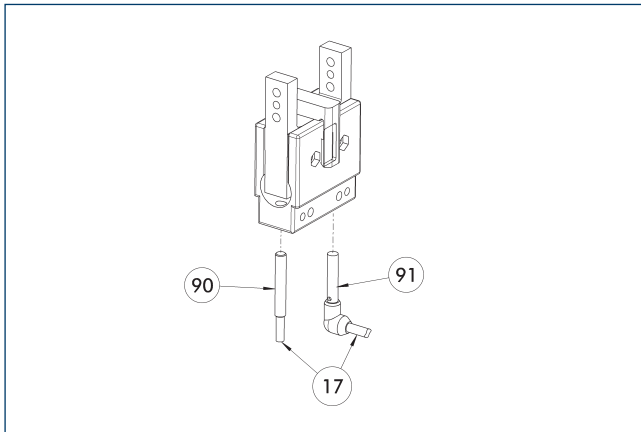

17 Cable outlet

91 Sensor IN..-SA

90 Sensor IN ...

Directly mounted end position monitoring.

Description	ID	Often combined
Inductive proximity switches		
IN 40-0-M12	0301584	
IN 40-0-M8	0301484	●
IN 40-S-M12	0301574	
IN 40-S-M8	0301474	●
INK 40-0	0301556	
INK 40-S	0301555	
Inductive proximity switch with lateral cable outlet		
IN 40-S-M12-SA	0301577	
IN 40-S-M8-SA	0301473	●
INK 40-S-SA	0301565	
Connection cables		
KA BG08-L 3P-0300-PNP	0301622	●
KA BG08-L 3P-0500-PNP	0301623	
KA BG12-L 3P-0500-PNP	30016369	
KA BW08-L 3P-0300-PNP	0301594	
KA BW08-L 3P-0500-PNP	0301502	
KA BW12-L 3P-0300-PNP	0301503	
KA BW12-L 3P-0500-PNP	0301507	
clip for plug/socket		
CLI-M12	0301464	
CLI-M8	0301463	
Cable extension		
KV BG12-SG12 3P-0030-PNP	0301999	
KV BG12-SG12 3P-0060-PNP	0301998	
KV BW08-SG08 3P-0030-PNP	0301495	
KV BW08-SG08 3P-0100-PNP	0301496	
KV BW08-SG08 3P-0200-PNP	0301497	●
KV BW12-SG12 3P-0030-PNP	0301595	
KV BW12-SG12 3P-0100-PNP	0301596	
KV BW12-SG12 3P-0200-PNP	0301597	
Sensor distributor		
V2-M12	0301776	●
V2-M8	0301775	●
V4-M8	0301746	
V8-M8	0301751	

① Two sensors are required per unit, one normally open (S) and one normally closed (O), as well as an optionally available extension cable.

SGB 50

Angular gripper



Gripping force O.D. gripping

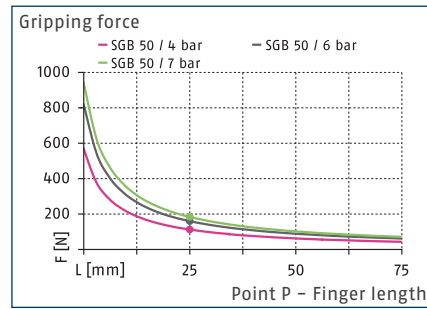

Closing moment curve

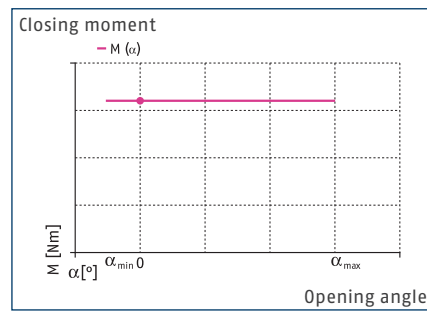

Dimensions and maximum loads

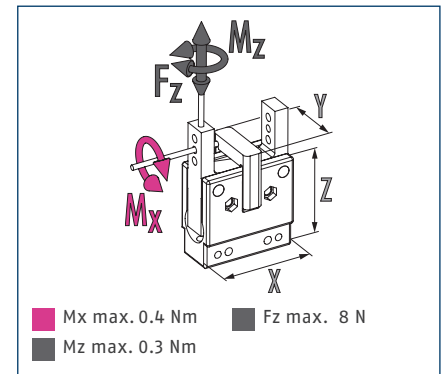

① The indicated torques and forces are static values, apply for each base jaw, and may occur simultaneously.

Technical data

Description		SGB 50
ID		0305201
Opening angle per jaw	[°]	8
Closed angle per jaw up to	[°]	2
Closing moment	[Nm]	4.95
Weight	[kg]	0.06
Recommended workpiece weight	[kg]	0.8
Fluid consumption double stroke	[cm ³]	1.8
Min./nom./max. operating pressure	[bar]	4/6/7
Closing/opening time	[s]	0.08/0.05
Max. permissible finger length	[mm]	50
Max. permissible mass per finger	[kg]	0.07
IP protection class		20
Min./max. ambient temperature	[°C]	5/90
Repeat accuracy	[mm]	0.1
Min. pressing on force	[N]	4
Pressure stroke	[mm]	5
Dimensions X x Y x Z	[mm]	50 x 31.2 x 50

Inductive Proximity Switches

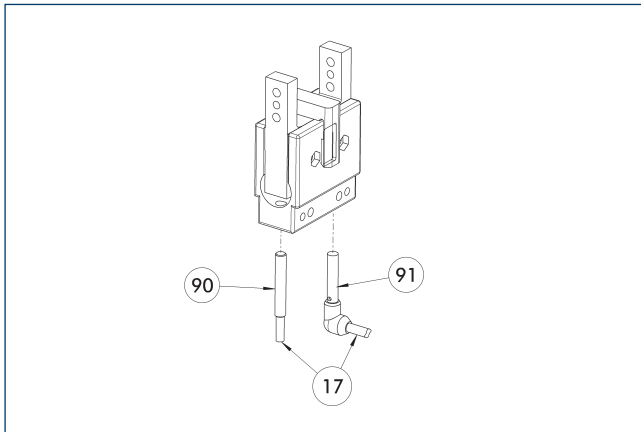

17 Cable outlet

91 Sensor IN..-SA

90 Sensor IN ...

Directly mounted end position monitoring.

Description	ID	Often combined
Inductive proximity switches		
IN 40-0-M12	0301584	
IN 40-0-M8	0301484	●
IN 40-S-M12	0301574	
IN 40-S-M8	0301474	●
INK 40-0	0301556	
INK 40-S	0301555	
Inductive proximity switch with lateral cable outlet		
IN 40-S-M12-SA	0301577	
IN 40-S-M8-SA	0301473	●
INK 40-S-SA	0301565	
Connection cables		
KA BG08-L 3P-0300-PNP	0301622	●
KA BG08-L 3P-0500-PNP	0301623	
KA BG12-L 3P-0500-PNP	30016369	
KA BW08-L 3P-0300-PNP	0301594	
KA BW08-L 3P-0500-PNP	0301502	
KA BW12-L 3P-0300-PNP	0301503	
KA BW12-L 3P-0500-PNP	0301507	
clip for plug/socket		
CLI-M12	0301464	
CLI-M8	0301463	
Cable extension		
KV BG12-SG12 3P-0030-PNP	0301999	
KV BG12-SG12 3P-0060-PNP	0301998	
KV BW08-SG08 3P-0030-PNP	0301495	
KV BW08-SG08 3P-0100-PNP	0301496	
KV BW08-SG08 3P-0200-PNP	0301497	●
KV BW12-SG12 3P-0030-PNP	0301595	
KV BW12-SG12 3P-0100-PNP	0301596	
KV BW12-SG12 3P-0200-PNP	0301597	
Sensor distributor		
V2-M12	0301776	●
V2-M8	0301775	●
V4-M8	0301746	
V8-M8	0301751	

① Two sensors are required per unit, one normally open (S) and one normally closed (O), as well as an optionally available extension cable.



SCHUNK GmbH & Co. KG
Spann- und Greiftechnik

Bahnhofstr. 106 - 134
D-74348 Lauffen/Neckar
Tel. +49-7133-103-0
Fax +49-7133-103-2399
info@de.schunk.com
schunk.com

Folgen Sie uns | *Follow us*

