

8908 - 8 Pc. Ratcheting Nut Driver Set SAE

Item No.	Description
890005GD	Ratcheting Screwdriver Stubby Handle - Red
890060GD	3/16" Nut Driver Shaft
890080GD	1/4" Nut Driver Shaft
890100GD	5/16" Nut Driver Shaft
890110GD	11/32" Nut Driver Shaft
890120GD	3/8" Nut Driver Shaft
890140GD	7/16" Nut Driver Shaft
890160GD	1/2" Nut Driver Shaft



8909 - 9 Pc. Ratcheting Nut Driver Set METRIC

Item No.	Description
890005GD	Ratcheting Screwdriver Stubby Handle - Red
891050GD	5mm Nut Driver Shaft
891060GD	6mm Nut Driver Shaft
891070GD	7mm Nut Driver Shaft
891080GD	8mm Nut Driver Shaft
891090GD	9mm Nut Driver Shaft
891100GD	10mm Nut Driver Shaft
891110GD	11mm Nut Driver Shaft
891120GD	12mm Nut Driver Shaft



Open Stock - Bit Sets and Adapters

Item No.	Description	Weight (lbs)
312901GD	Adapter for 13 mm Vortex® Socket	0.040
890002GD	1/4" Hex Shank Bit Adapter	0.030
890003GD	30 Pc. Bit Set in Box	0.539
890004GD	31 Pc. Bit Set in Box: Includes 1/4" Drive to Bit Adapter	0.030
890007GD	Adapter for Connecting Two 1/4" Shafts	0.048
890010GD	10 Pc. Bit Set with Holder	0.508

Open Stock - Ratcheting Screwdriver Handles and Shafts



Item No.	Description	Length	Weight (lbs)
890006GD	Ratcheting Screwdriver T-Handle - Red		0.364
890001GD	Ratcheting Screwdriver Handle - Red		0.300
890005GD	Ratcheting Screwdriver Stubby Handle - Red		0.293
310903GR	1/4" Shank Magnetic Bit Shaft	10"	0.239
310902GR	1/4" Shank Magnetic Bit Shaft	6"	0.142
310901GR	1/4" Shank Magnetic Bit Shaft	3.5"	0.085
311902GR	1/4" Shank Socket Shaft	6"	0.130
311903GR	1/4" Shank Flexible Socket Shaft	6"	0.136
311904GR	1/4" Shank Socket Shaft	10"	0.134
311901GR	1/4" Shank Socket Shaft	3.5"	0.076

Open Stock - Ratcheting Nut Driver Shafts



Item No.	Description	Weight (lbs)	Item No.	Description	Weight (lbs)
890008GD	11" 1/4" Shank 180® Flex Bit Shaft	0.272	891050GD	5 mm Nut Driver Shaft	0.082
890009GD	11" 1/4" Shank 180® Flex Socket Shaft	0.27	891060GD	6 mm Nut Driver Shaft	0.082
890060GD	3/16" Nut Driver Shaft	0.083	891070GD	7 mm Nut Driver Shaft	0.083
890080GD	1/4" Nut Driver Shaft	0.083	891080GD	8 mm Nut Driver Shaft	0.086
890140GD	7/16" Nut Driver Shaft	0.106	891090GD	9 mm Nut Driver Shaft	0.091
890160GD	1/2" Nut Driver Shaft	0.115	891100GD	10 mm Nut Driver Shaft	0.093
890120GD	3/8" Nut Driver Shaft	0.093	891110GD	11 mm Nut Driver Shaft	0.106
890100GD	5/16" Nut Driver Shaft	0.089	891120GD	12 mm Nut Driver Shaft	0.114
890110GD	11/32" Nut Driver Shaft	0.09			

SCREWDRIVERS OPEN STOCK

PLIERS

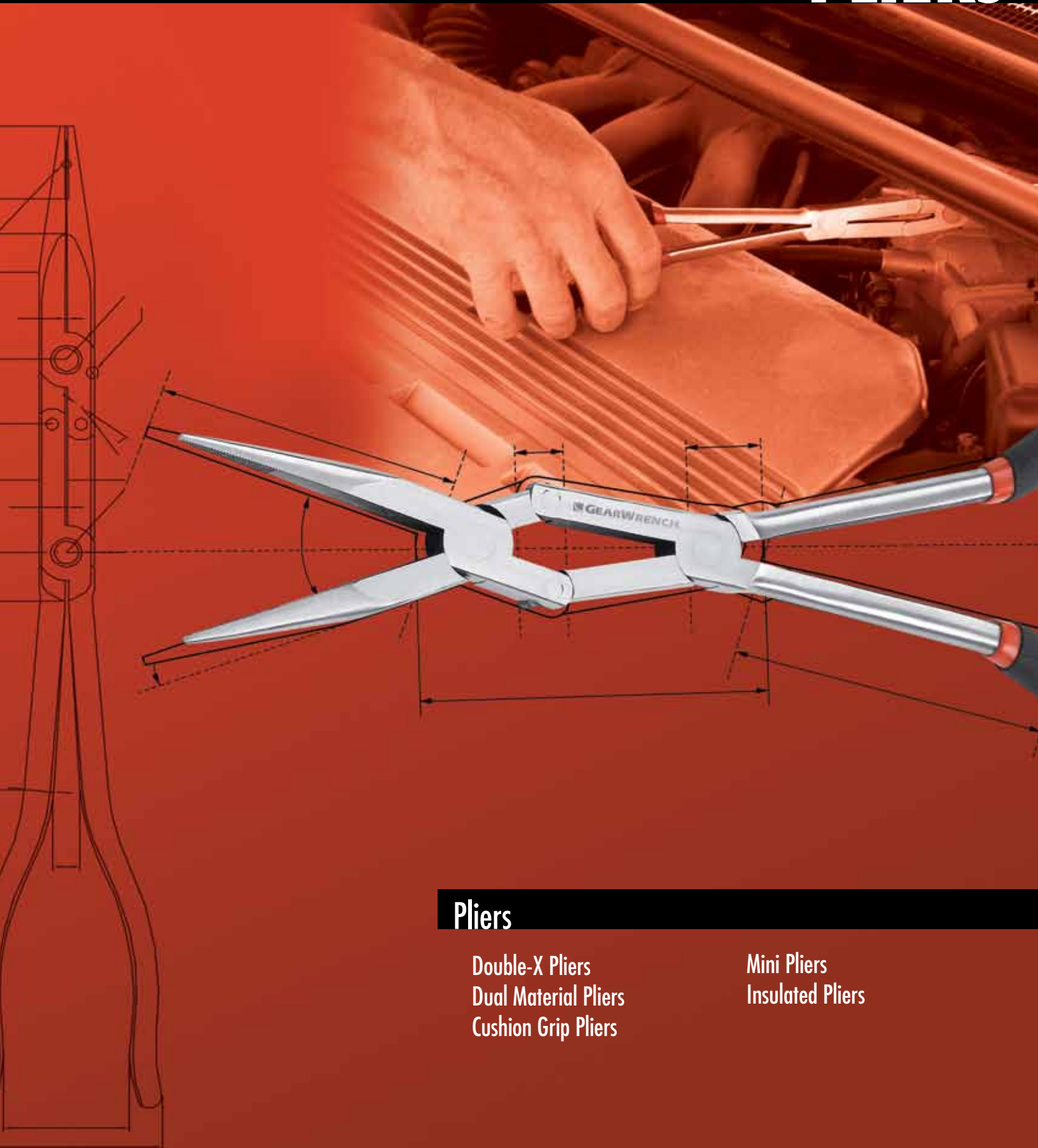

Pliers

Double-X Pliers
Dual Material Pliers
Cushion Grip Pliers

Mini Pliers
Insulated Pliers

**DOUBLE-X™
PLIERS**

PLIERS

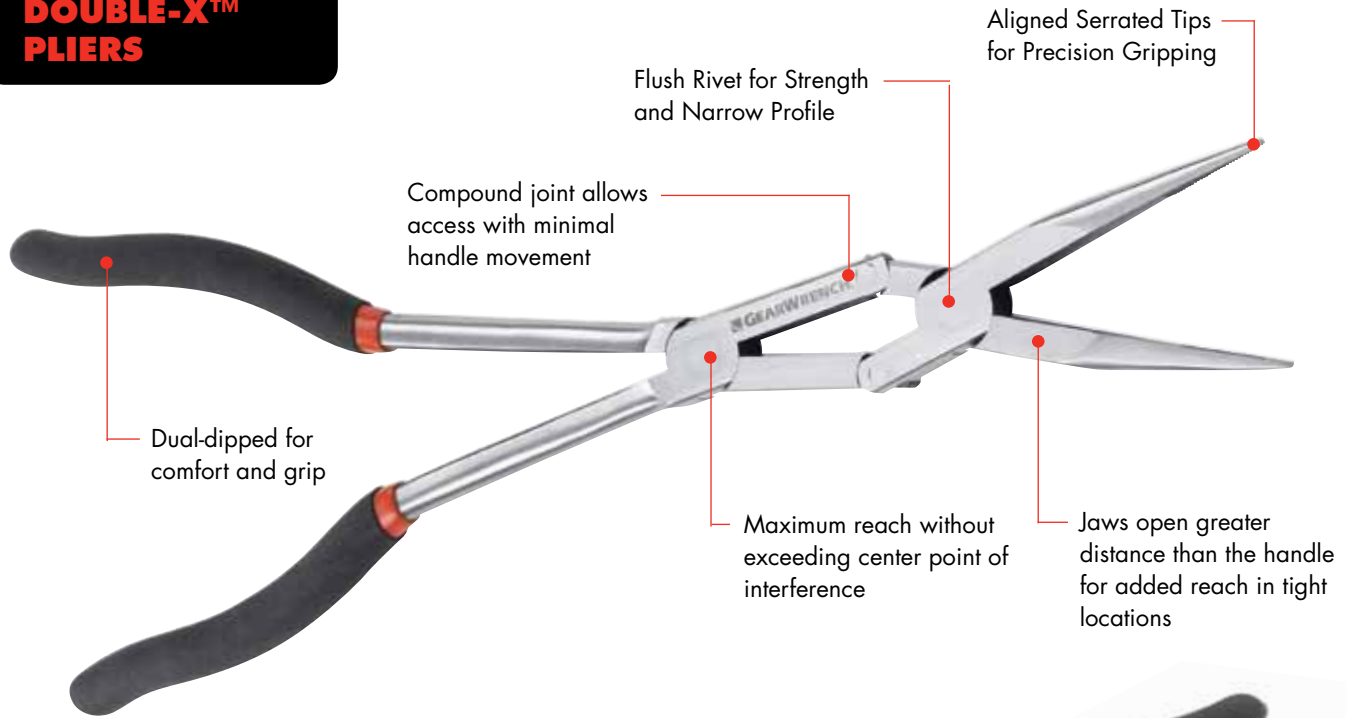

AVAILABLE IN:

- Straight Standard Pliers
- 45° Standard Pliers
- Duck Bill Standard Pliers
- Internal / External Snap Ring Pliers
- Straight Hemostat Pliers
- 45° Hemostat Pliers



APPLICATIONS

- Long reach cotter pin removal
- Use as a pick-up tool
- Tight access under engine cowlings in aviation and automotive
- Electrical terminal removal and installation

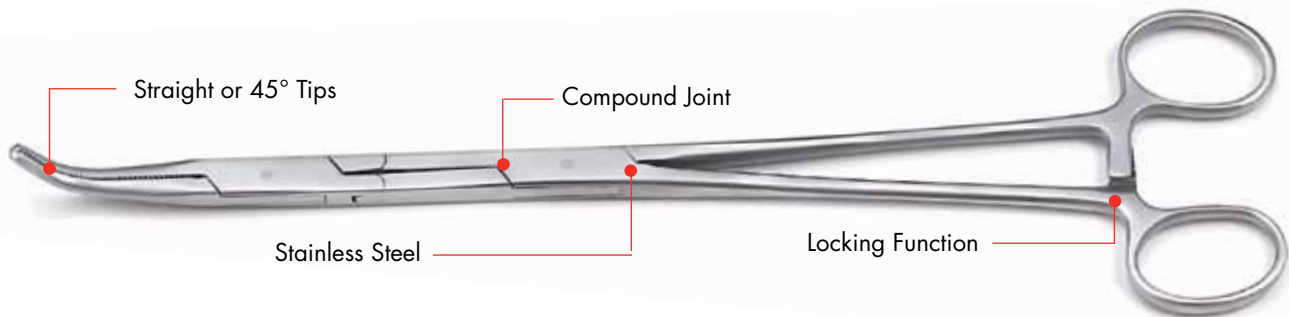

DUAL MATERIAL GRIP PLIERS

- AVAILABLE IN:**
- Slip Joint Pliers
 - Duck Bill Pliers
 - Diagonal Pliers
 - Linesmans Pliers
 - Bent Nose Pliers
 - Groove Joint Pliers
 - Long Nose Pliers
 - Fence Pliers



CUSHION GRIP PLIERS





82108 - 7 Pc. Mixed Pliers Set

Item No.	Description
82011	Tongue and Groove Pliers
82012	Diagonal Cutting Pliers
82013	Long Nose Pliers
82014	Slip Joint Pliers
82020	12" Groove Joint Pliers with Straight Jaw
82025	8" Linesman Pliers
82028	8" End Nipper Pliers

Weight 5.5 lbs

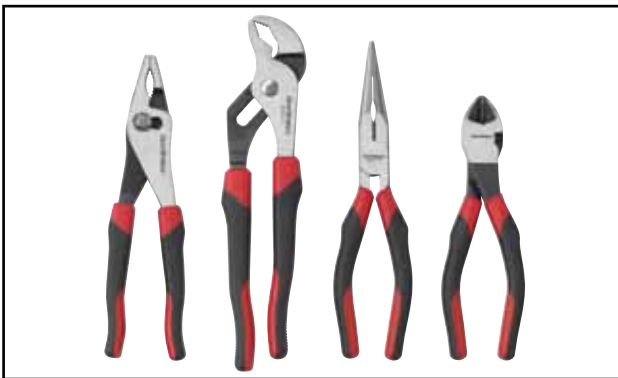

82103 - 4 Pc. Mixed Pliers Set

Item No.	Description
82011	Tongue and Groove Pliers
82012	Diagonal Cutting Pliers
82013	Long Nose Pliers
82014	Slip Joint Pliers

Weight 3.1 lbs



82104 - 3 Pc. Mixed Pliers Set

Item No.	Description
82011	Tongue and Groove Pliers
82012	Diagonal Cutting Pliers
82013	Long Nose Pliers

Weight 2.5 lbs



80058 - 8 Pc. Mini Screwdriver & Pliers Set

Item No.	Description
82001	Long Nose Mini Pliers
82000	Diagonal Cutting Mini Pliers
80034	1.5 mm Mini Slotted Screwdriver
80035	2.0 mm Mini Slotted Screwdriver
80036	2.5 mm Mini Slotted Screwdriver
80031	#00 Mini Phillips Screwdriver
80032	#0 Mini Phillips Screwdriver
80033	#1 Mini Phillips Screwdriver

Weight 1.5 lbs

82100 - 5 Pc. Mixed Mini Pliers Set

Item No.	Description
82000	Diagonal Cutting Mini Pliers
82001	Long Nose Mini Pliers
82002	Needle Nose Mini Pliers
82003	End Cutting Nipper Mini Pliers
82004	Flat Nose Mini Pliers

Weight 0.99 lbs



Open Stock - Slip Joint Pliers

Item No.	Size	Jaw Length A	Jaw Width B	Jaw Thickness C	Overall Length D	Weight (lbs)
82022	6"	1.73"	1.17"	0.41"	6.85"	0.16
82014	8"	1.72"	1.24"	0.14"	8.15"	0.29

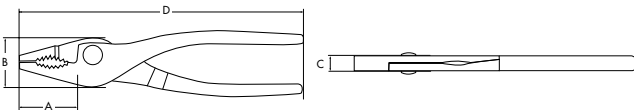

82011 - 9.5" Tongue and Groove Pliers

Jaw Length A	Jaw Width B	Jaw Thickness C	Overall Length D	Weight (lbs)
1.61"	0.73"	0.41"	9.45"	0.59

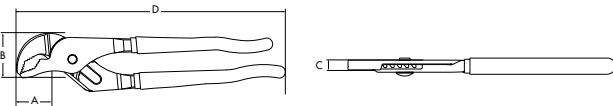

82020 - 12" Groove Joint Pliers with Straight Jaw

Jaw Length A	Jaw Width B	Jaw Thickness C	Overall Length D	Weight (lbs)
2.09"	0.65"	0.47"	11.85"	1.19

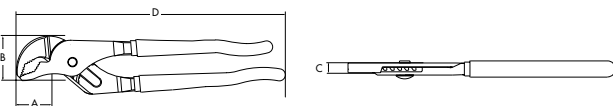



Open Stock - Diagonal Cutting Pliers

Item No.	Size	Jaw Length A	Jaw Width B	Jaw Thickness C	Overall Length D	Weight (lbs)
82008	6"	1.13"	0.75"	0.42"	6.06"	0.16
82012	7"	1.12"	1.2"	0.46"	7.01"	0.26

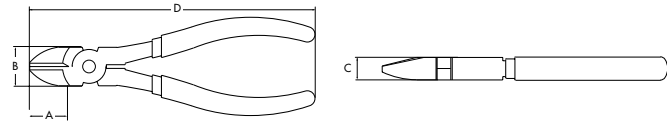

Open Stock - Long Nose Pliers

Item No.	Size	Jaw Length A	Jaw Width B	Jaw Thickness C	Overall Length D	Weight (lbs)
82010	6"	2.32"	0.69"	0.35"	6.5"	0.17
82013	8"	3.28"	0.84"	0.42"	8.23"	0.24

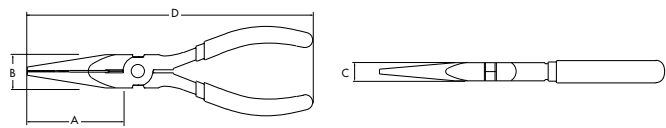

82038 - 8" Long Bent Nose Bent Pliers

Jaw Length A	Jaw Width B	Jaw Thickness C	Overall Length D	Weight (lbs)
3.28"	0.84"	0.42"	8.23"	0.24

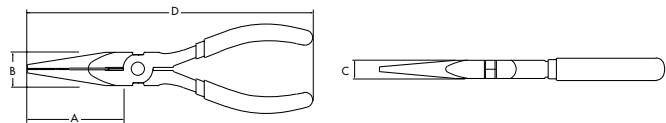

82025 - 8" Linesman Pliers

Jaw Length A	Jaw Width B	Jaw Thickness C	Overall Length D	Weight (lbs)
2.14"	1.13"	0.48"	8.03"	0.46

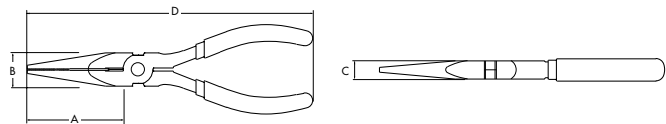

82028 - 8" End Nipper Pliers

Jaw Length A	Jaw Width B	Jaw Thickness C	Overall Length D	Weight (lbs)
0.59"	1.17"	1.02"	7.8"	0.33

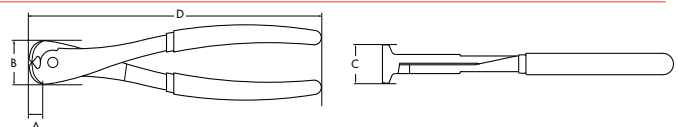

82000 - 5" Mini Diagonal Cutting Pliers

Jaw Length A	Jaw Width B	Jaw Thickness C	Overall Length D	Weight (lbs)
0.51"	0.33"	0.51"	4.45"	0.09

- Springed Handles

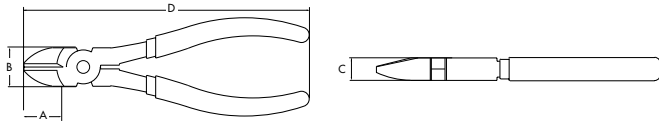

81999 - 5" Mini Bent Nose Pliers

Jaw Length A	Jaw Width B	Jaw Thickness C	Overall Length D	Weight (lbs)
1.32"	0.5"	0.33"	5.2"	0.09

- Springed Handles

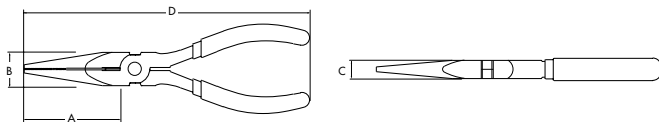

82001 - 5" Mini Long Nose Pliers

Jaw Length A	Jaw Width B	Jaw Thickness C	Overall Length D	Weight (lbs)
1.47"	0.5"	0.33"	5.2"	0.09

- Springed Handles

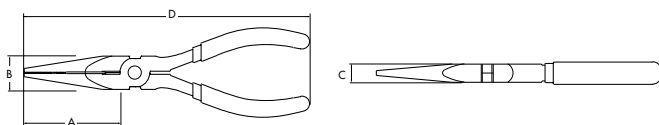

82002 - 5" Mini Needle Nose Pliers

Jaw Length A	Jaw Width B	Jaw Thickness C	Overall Length D	Weight (lbs)
1.84"	0.5"	0.33	5.59"	0.09

- Springed Handles

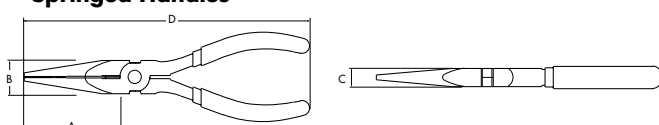



82003 - Mini End Cutting Nipper Pliers

Jaw Length A	Jaw Width B	Jaw Thickness C	Overall Length D	Weight (lbs)
0.51"	0.5"	0.51"	4.25"	0.09

- Springed Handles

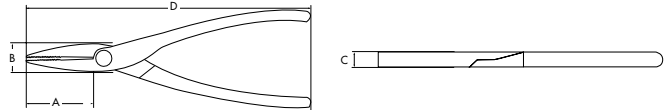

82004 - Mini Flat Nose Pliers

Jaw Length A	Jaw Width B	Jaw Thickness C	Overall Length D	Weight (lbs)
1.47"	0.5"	0.33"	5.2"	0.09

- Springed Handles

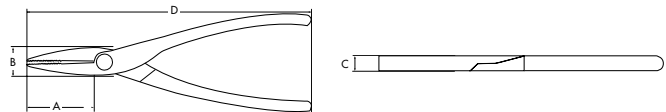

82106 - 2 Pc. Double-X™ Pliers Set

Item No.	Description
82005	Straight Double-X™ Pliers
82006	45 Degree Double-X™ Pliers

Weight 1.81 lbs



82107 - 3 Pc. Double-X™ Hose Grip Pliers Set

Item No.	Description
82017	5/16" Dia. Hose Grip Double-X™ Pliers
82018	1/2" Dia. Hose Grip Double-X™ Pliers
82019	3/4" Dia. Hose Grip Double-X™ Pliers

Weight 3.07 lbs

82110 - 2 Pc. Double-X™ Internal/External Snap Ring Pliers Set

Item No.	Description
82032	Double-X™ Internal Snap Ring Pliers
82033	Double-X™ External Snap Ring Pliers
	.038, Straight
	.038, 90°
	.047, Straight
	.047, 90°
	.070, Straight
	2 mm Hex Key
3151-77	Replacement Tip Set

Weight 1.81 lbs



82111 - 2 Pc. Double-X™ Hemostat Pliers Set

Item No.	Description
82034	Double-X™ Straight Hemostat Pliers
82035	Double-X™ 45 Degree Hemostat Pliers

Weight 0.52 lbs



82005 - Straight Double-X™ Pliers

Jaw Length A	Jaw Width B	Jaw Thickness C	Overall Length D	Weight (lbs)
3.15"	0.68"	0.39"	13.46"	0.84

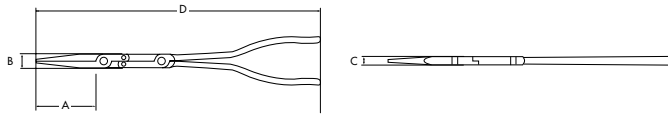

82006 - 45 Degree Double-X™ Pliers

Jaw Length A	Jaw Width B	Jaw Thickness C	Overall Length D	Weight (lbs)
2.95"	0.68"	0.39"	13.27"	0.86

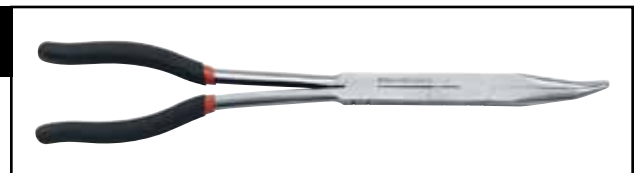
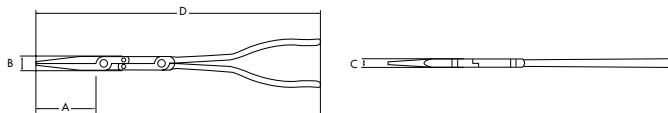



82007 - Duck Bill Double-X™ Pliers

Jaw Length A	Jaw Width B	Jaw Thickness C	Overall Length D	Weight (lbs)
1.65"	0.68"	0.39"	11.97"	0.79

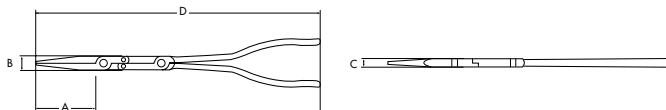

Open Stock - Hose Grip Double-X™ Pliers

Item No.	Size	Jaw Length A	Jaw Width B	Jaw Thickness C	Overall Length D	Weight (lbs)
82017	5/16"	2.87"	0.68"	0.39"	13.19"	0.83
82018	1/2"	2.81"	0.68"	0.39"	13.13"	0.83
82019	3/4"	2.72"	0.68"	0.39"	13.03"	0.83

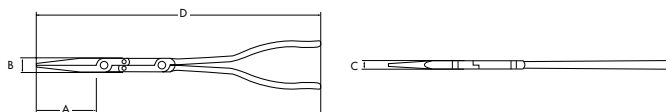

82032 - Double-X™ Internal Snap Ring Pliers

Jaw Length A	Jaw Width B	Jaw Thickness C	Overall Length D	Weight (lbs)
3.15"	0.68"	0.39"	13.46"	0.88

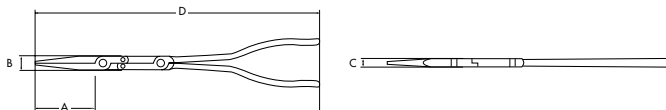

82033 - Double-X™ External Snap Ring Pliers

Jaw Length A	Jaw Width B	Jaw Thickness C	Overall Length D	Weight (lbs)
3.15"	0.68"	0.39"	13.46"	0.88

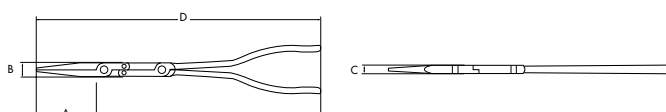

82034 - Double-X™ Straight Hemostat Pliers

Jaw Length A	Jaw Width B	Jaw Thickness C	Overall Length D	Weight (lbs)
4.22"	0.16"	0.13"	9.84"	0.21

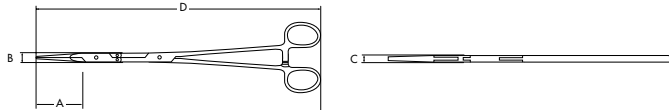

82035 - Double-X™ 45 Degree Hemostat Pliers

Jaw Length A	Jaw Width B	Jaw Thickness C	Overall Length D	Weight (lbs)
4.09"	0.16"	0.13"	9.73"	0.21

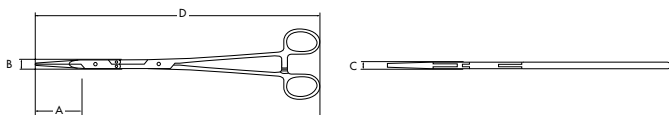

82097 - 6 Pc. Pliers Set

Item No.	Description
82079	6" Slip Joint Pliers
82081	6" Diagonal Pliers
82085	6" Long Nose Pliers
82088	8" Duck Bill Pliers
82090	9" Linesmans Pliers
82093	9-1/2" Groove Joint Pliers Diamond Jaw

Weight 5.00 lbs



82098 - 4 Pc. Pliers Set

Item No.	Description
82079	6" Slip Joint Pliers
82082	8" Wide Jaw Diagonal Pliers
82086	8" Long Nose Pliers
82093	9-1/2" Groove Joint Pliers Diamond Jaw

Weight 3.50 lbs





82099 - 3 Pc. Groove Joint Pliers Set

Item No.	Description
82093	9-1/2" Groove Joint Pliers Diamond Jaw
82094	12" Groove Joint Pliers Straight Jaw
82095	16" Groove Joint Pliers Straight Jaw

Weight 2.50 lbs



Open Stock - Slip Joint Pliers

Item No.	Size	Jaw Length A	Jaw Width B	Jaw Thickness C	Overall Length D	Weight (lbs)
82079	6"	1.73"	1.17"	0.41"	6.85"	0.16
82080	8"	1.72"	1.24"	0.41"	8.15"	0.29

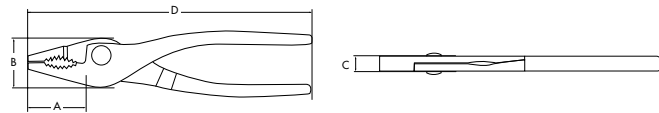

Open Stock - Groove Joint Pliers

Item No.	Description	Jaw Length A	Jaw Width B	Jaw Thickness C	Overall Length D	Weight (lbs)
82092	8" Straight Jaw	1.41"	1.81"	0.37"	7.72"	0.26
82093	9-1/2" Diamond Jaw	1.61"	0.73"	0.41"	9.45"	0.43
82094	12" Straight Jaw	2.09"	0.65"	0.47"	11.85"	0.62
82095	16" Straight Jaw	2.83"	0.95"	0.57"	16.02"	1.19

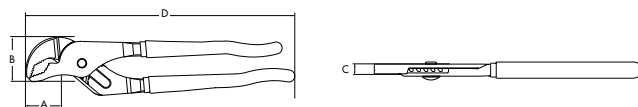

82081 - 6" Diagonal Pliers

Jaw Length A	Jaw Width B	Jaw Thickness C	Overall Length D	Weight (lbs)
1.27"	0.81"	0.47"	6.06"	0.16

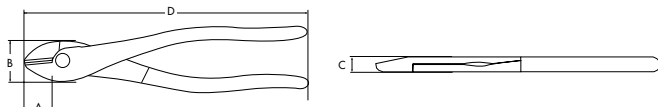

82082 - 7" Wide Jaw Diagonal Pliers

Jaw Length A	Jaw Width B	Jaw Thickness C	Overall Length D	Weight (lbs)
1.11"	1.21"	0.46"	7.99"	0.34

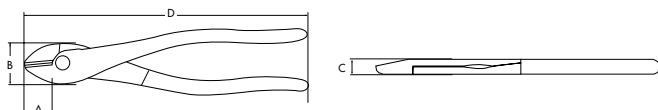

82083 - 8" Bent Nose Diagonal Pliers

Jaw Length A	Jaw Width B	Jaw Thickness C	Overall Length D	Weight (lbs)
1.11"	1.21"	0.46"	7.99"	0.34

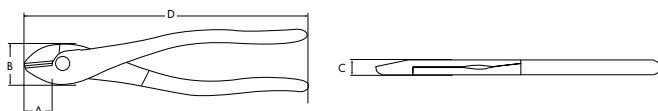

Open Stock - Long Nose Pliers

Item No.	Description	Jaw Length A	Jaw Width B	Jaw Thickness C	Overall Length D	Weight (lbs)
82085	6" Long Nose	2.61"	0.77"	0.41"	6.65"	0.17
82086	8" Long Nose	2.97"	0.89"	0.47"	7.99"	0.24

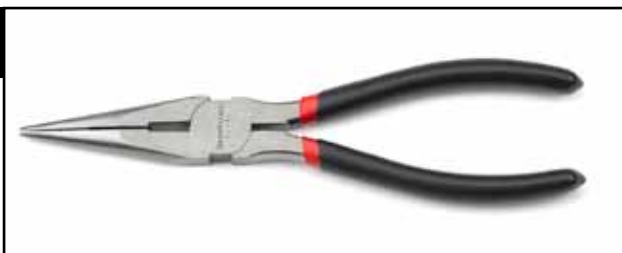
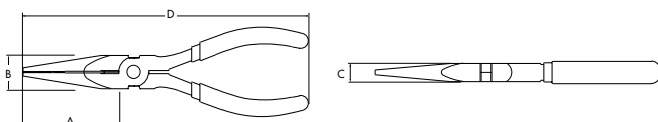



82087 - 6" Long Nose Bent Pliers

Jaw Length A	Jaw Width B	Jaw Thickness C	Overall Length D	Weight (lbs)
2.61"	0.77"	0.41"	6.65"	0.17

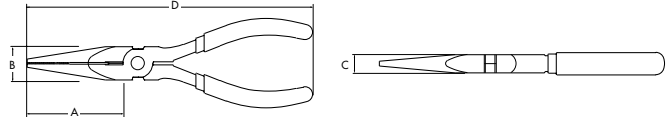

82088 - 8" Duck Bill Pliers

Jaw Length A	Jaw Width B	Jaw Thickness C	Overall Length D	Weight (lbs)
1.94"	0.51"	0.42"	7.83"	0.23

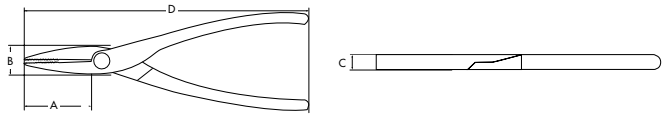

Open Stock - Linesman Pliers

Item No.	Size	Jaw Length A	Jaw Width B	Jaw Thickness C	Overall Length D	Weight (lbs)
82089	8"	1.76"	1.19"	0.61"	8.9"	0.36
82090	9"	1.88"	1.24"	0.61"	9.41"	0.40

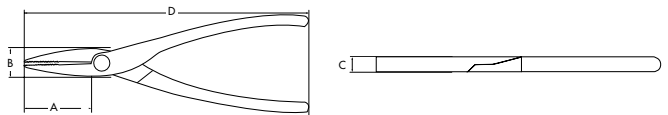

82084 - 8" End Nippers

Jaw Length A	Jaw Width B	Jaw Thickness C	Overall Length D	Weight (lbs)
0.59"	1.17"	1.02"	7.8"	0.33

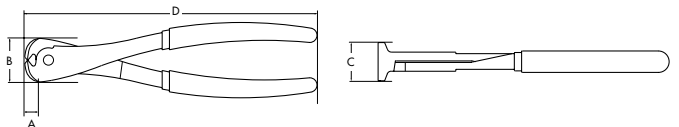

82096 - 10" Fence Pliers

Jaw Length A	Jaw Width B	Jaw Thickness C	Overall Length D	Weight (lbs)
1.55"	3.17"	0.57"	10.51"	0.68



82078 - 10" Universal Cutting Pliers

Jaw Length A	Jaw Width B	Jaw Thickness C	Overall Length D	Blade Length	Weight (lbs)
1.58"	2.56"	0.67"	10.24"	3-7/8"	1.02



80062 - 10 Pc. Insulated Pliers and Screwdriver Set

Item No.	Description
80047	3/32" (2.5mm) x 3" Insulated Slotted Screwdriver
80048	5/32" (4.0mm) x 4" Insulated Slotted Screwdriver
80049	7/32" (5.5mm) x 5" Insulated Slotted Screwdriver
80081	#1 x 3-1/8" Insulated Phillips Screwdriver
80082	#2 x 4" Insulated Phillips Screwdriver
80084	#1 x 3-1/8" Insulated Pozidriv-Plus Screwdriver
80085	#2 x 4" Insulated Pozidriv-Plus Screwdriver
82029	Lineman Insulated Pliers
82030	Long Nose Insulated Pliers
82031	Diagonal Cutting Insulated Pliers



Weight 3.50



82029 - 8" Lineman Insulated Pliers

Jaw Length A	Jaw Width B	Jaw Thickness C	Overall Length D	Weight (lbs)
2.22"	1.22"	0.51"	8.31"	0.40

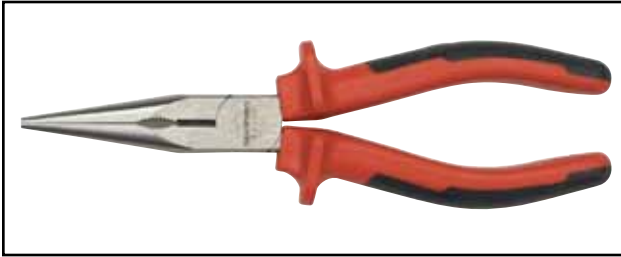
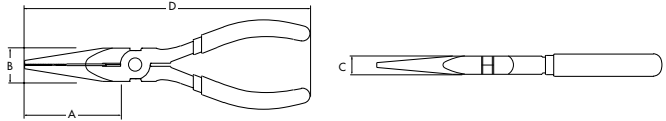

82030 - 8" Long Nose Insulated Pliers

Jaw Length A	Jaw Width B	Jaw Thickness C	Overall Length D	Weight (lbs)
3.26"	0.87"	0.43"	8.39"	0.30

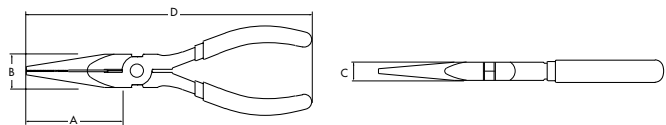

82031 - 7" Diagonal Cutting Insulated Pliers

Jaw Length A	Jaw Width B	Jaw Thickness C	Overall Length D	Weight (lbs)
1.22"	1.18"	0.47"	7.4"	0.30

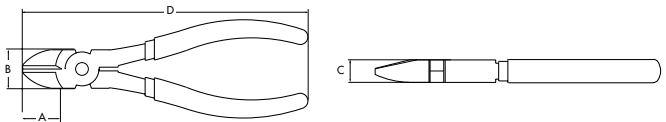

82102 - 3 Pc. Locking Pliers Set

Item No.	Description
82043	6" Long Nose Locking Pliers
82040	5" Curved Jaw Locking Pliers
82041	10" Curved Jaw Locking Pliers

Weight 4.00

82112 - 5 Pc. Locking Pliers Set

Item No.	Description
82043	6" Long Nose Locking Pliers
82040	5" Curved Jaw Locking Pliers
82041	10" Curved Jaw Locking Pliers
82045	6" C-Clamp Locking Pliers
82046	11" C-Clamp Locking Pliers

Weight 5.50



Open Stock - Jaw Locking Pliers

Item No.	Description	Jaw Length A	Jaw Width B	Jaw Thickness C	Overall Length D	Weight (lbs)
82040	5" Curved	1.57"	1.73"	0.31"	5.51"	0.38
82041	10" Curved	2.36"	2.63"	0.43"	8.79"	1.11
82042	10" Straight	2.56"	2.65"	0.55"	8.71"	1.13

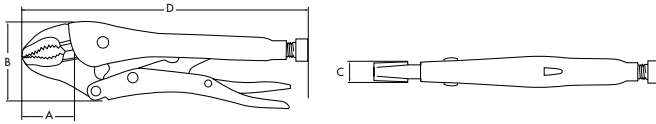

Open Stock - Long Nose Locking Pliers

Item No.	Size	Jaw Length A	Jaw Width B	Jaw Thickness C	Overall Length D	Weight (lbs)
82043	6"	2.76"	1.57"	0.12"	6.56"	0.41
82044	9"	3.7"	2.16"	0.2"	8.94"	0.84

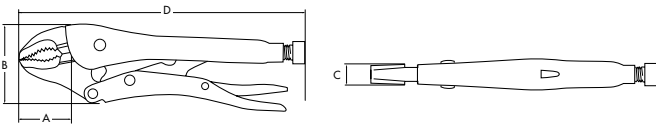



C-Clamp Locking Pliers

Item No.	Size	Jaw Length A	Jaw Width B	Jaw Thickness C	Overall Length D	Weight (lbs)
82045	6"	2.68"	3.38"	0.35"	6.79"	0.48
82046	11"	4.53"	5.62"	0.41"	11.28"	1.66
82047	18"	11.81"	6.37"	0.41"	18.57"	2.97
82048	24"	17.72"	7.1"	0.41"	24.45"	3.19

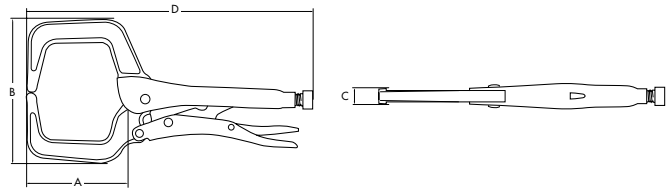

Swivel Pad C-Clamp Locking Pliers

Item No.	Size	Jaw Length A	Jaw Width B	Jaw Thickness C	Overall Length D	Weight (lbs)
82049	6"	29.53"	3.38"	0.8"	6.79"	0.49
82050	11"	4.92"	5.62"	1.11"	11.28"	1.70
82051	18"	12.32"	6.36"	1.11"	18.13"	3.30
82052	24"	18.23"	7.12"	1.11"	24.03"	3.19

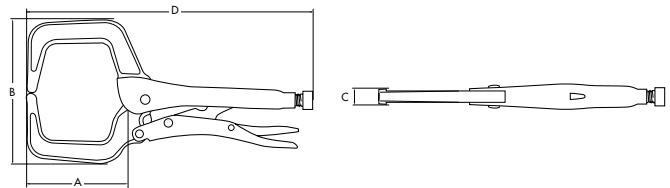

82053 - 20" Chain Clamp Locking Pliers

Jaw Length A	Jaw Width B	Jaw Thickness C	Overall Length D	Weight (lbs)
2.87"	2.49"	0.23"	8.5"	1.58

PRY BARS



Pry Bars

- Indexing Pry Bar
- Extendable Pry Bar
- Pry Bar Sets
- Indexing Nail Puller

INDEXING PRY BARS

PRY BARS

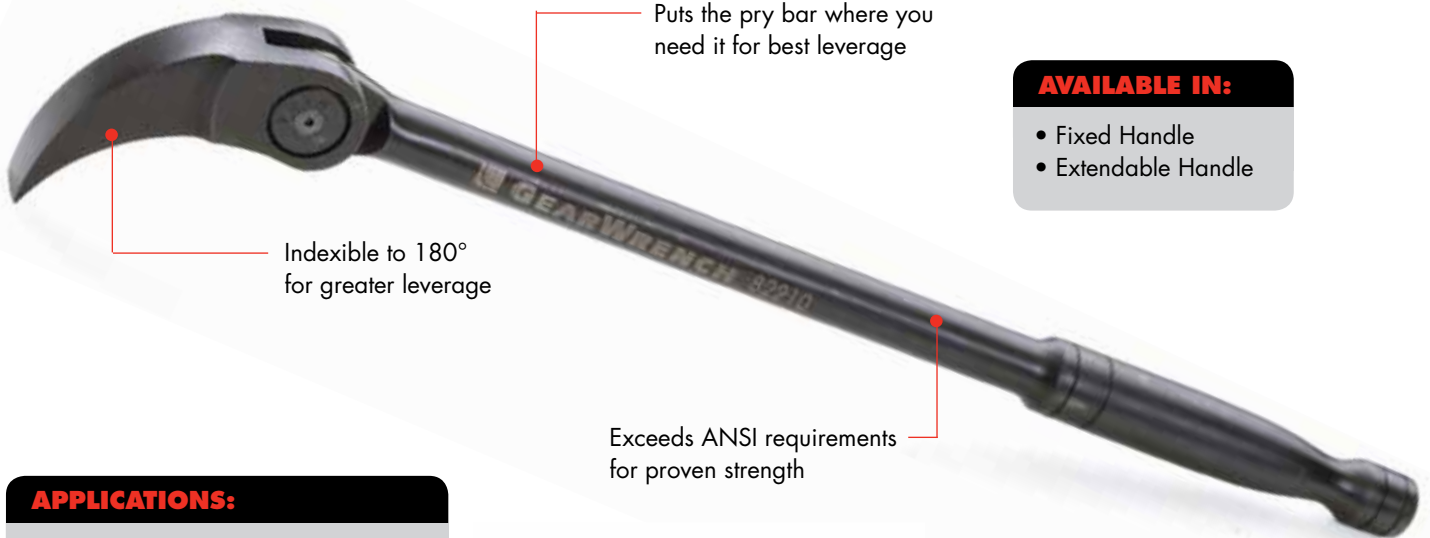

Indexible to 180° for greater leverage

Puts the pry bar where you need it for best leverage

Exceeds ANSI requirements for proven strength

- AVAILABLE IN:**
- Fixed Handle
 - Extendable Handle

- APPLICATIONS:**
- Demolition of roof rafters and floor joists
 - Removing broken concrete
 - Repositioning equipment
 - Aligning steel components and fabrications
 - Engine repositioning and placement



14 Locking positions for unmatched access

Grooved profile adds traction on 24", 33" and Extendable Models





Extendable pry bar extends for greater access and leverage and collapses so you can store it securely in your tool box



Extends from 29" to 48"



Push button to extend reach



INDEXIBLE NAIL PULLER



14 Locking positions for unmatched access

12" Long Handle for Access

Striking Face

Indexes to 180°

Fits Nail Sizes 4D to 10D

Products are covered by one or more of the following patents:
• US 6,840,141

PRY BARS



82300 - 2 Pc. Pry Bar Set

Item No.	Description
82216	16" Indexing Pry Bar
82208	8" Indexing Pry Bar



82301 - 3 Pc. Pry Bar Set

Item No.	Description
82216	16" Indexing Pry Bar
82210	10" Indexing Pry Bar
82208	8" Indexing Pry Bar



Open Stock - Indexing Pry Bar

Item No.	Description
82208	8" Indexing Pry Bar
82210	10" Indexing Pry Bar
82216	16" Indexing Pry Bar
82224	24" Indexing Pry Bar
82233	33" Indexing Pry Bar



Open Stock - Extendable Pry Bar

Item No.	Description
82220	18" to 29" Extendable Pry Bar
82248	29" to 48" Extendable Pry Bar



82212 - 12" Index Nail Puller

- Fits nail sizes 4D to 10D
- Indexible to 180°
- 14 locking positions

STRIKING & STRUCK TOOLS



Striking Tools

Hammers
Automotive Body Tools

Struck Tools

Punches
Chisels
Punch & Chisel Holder



CHISELS AND PUNCHES

AVAILABLE IN:

- Cold Chisels
- Center Punches
- Pin Punches
- Long Taper Punches
- Starter Punches

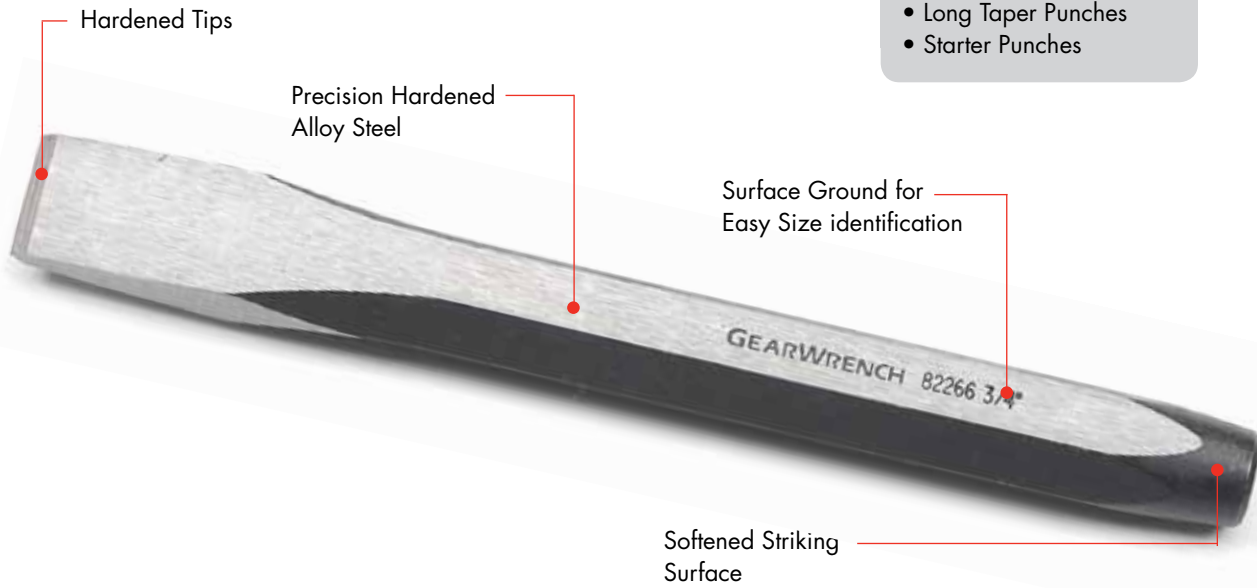

HAMMERS

AVAILABLE IN:

- Ball Pein
- Curved Claw
- Drilling
- Dead Blow
- Rubber Mallet
- Soft or Hard Face



STRIKING & STRUCK TOOLS

82303 - 5 Pc. Hammer Set

Item No.	Description
82251	16 oz. Ball Pein Hammer - Fiberglass
82255	3 lb Drilling Hammer
82260	12 oz. Soft Face Hammer - Removable Caps
82256	16 oz. Dead Blow Hammer - Composite Handle
82259	16 oz. Rubber Mallet - Wood Hickory Handle



82288 - 5 Pc. Ball Pein Hammer Set

Item No.	Description
82251	16 oz. Ball Pein Hammer - Fiberglass
82250	8 oz. Ball Pein Hammer - Fiberglass
82253	32 oz. Ball Pein Hammer - Fiberglass
82252	24 oz. Ball Pein Hammer - Fiberglass
82260	12 oz. Soft Face Hammer - Removable Caps



Open Stock - Ball Pein Hammers

Item No.	Description
82250	8 oz. Ball Pein Hammer - Fiberglass
82251	16 oz. Ball Pein Hammer - Fiberglass
82252	24 oz. Ball Pein Hammer - Fiberglass
82253	32 oz. Ball Pein Hammer - Fiberglass

- Use with struck tools, machine work, auto body, riveting, shaping metal



82254 - 16 oz. Claw Hammer Curved Claw - Fiberglass

- Driving nails, construction, multi-use, but not for punches and chisels



OPEN STOCK
STRIKING & STRUCK TOOLS



82255 - 3 lb Drilling Hammer

- For heavy duty use with punches, chisels, and star drills



82289 - 3 lb Engineers Hammer



82291 - 40 oz. Blacksmiths Hammer



82259 - 16 oz. Rubber Mallet - Wood Hickory Handle



82260 - 12 oz. Soft Face Hammer

- For light assembly applications where condition of work piece is important

Open Stock - Dead Blow Hammers

Item No.	Description
82258	48 oz. Dead Blow Hammer - Composite Handle
82256	16 oz. Dead Blow Hammer - Composite Handle
82257	32 oz. Dead Blow Hammer - Composite Handle

- **Multi-use applications in assembly, maintenance, production**



82306 - 27 Pc. Punch and Chisel Set

Item No.	Description
82261	1/4" x 4-3/4" x 1/4" Cold Chisel
82262	3/8" x 5" x 5/16" Cold Chisel
82263	7/16" x 5-1/2" x 3/8" Cold Chisel
82264	1/2" x 6" x 3/8" Cold Chisel
82265	5/8" x 6-1/2" x 3/8" Cold Chisel
82266	3/4" x 7" x 5/8" Cold Chisel
82267	7/8" x 7-1/2" x 3/4" Cold Chisel
82268	1" x 8" x 7/8" Cold Chisel
82269	1/4" x 4-1/4" Center Punch
82270	3/8" x 5" Center Punch
82271	7/16" x 5-1/2" Center Punch
82272	3/32" x 4-3/4" x 5/16" Pin Punch
82273	1/8" x 5" x 5/16" Pin Punch
82274	5/32" x 5-1/4" x 5/16" Pin Punch
82275	3/16" x 5-1/2" x 5/16" Pin Punch
82276	1/4" x 7" x 3/8" Pin Punch
82277	5/16" x 7" x 1/2" Pin Punch
82278	1/8" x 8" x 3/8" Long Taper Punch
82279	5/32" x 8-1/2" x 1/2" Long Taper
82280	3/16" x 9" x 1/2" Long Taper Punch
82281	1/4" x 11" x 5/8" Long Taper Punch
82282	5/32" x 5" x 3/8" Starter Punch
82283	3/16" x 5" x 3/8" Starter Punch
82284	1/4" x 6" x 1/2" Starter Punch
82285	1/8" x 4-1/2" x 5/16" Starter
82286	5/16" x 7" x 5/8" Starter Punch
82287	3/8" x 8" x 3/4" Starter Punch



OPEN STOCK

STRIKING & STRUCK TOOLS



82305 - 12 Pc. Punch and Chisel Set

Item No.	Description
82261	1/4" x 4-3/4" x 1/4" Cold Chisel
82262	3/8" x 5" x 5/16" Cold Chisel
82264	1/2" x 6" x 3/8" Cold Chisel
82265	5/8" x 6-1/2" x 3/8" Cold Chisel
82270	3/8" x 5" Center Punch
82272	3/32" x 4-3/4" x 5/16" Pin Punch
82273	1/8" x 5" x 5/16" Pin Punch
82274	5/32" x 5-1/4" x 5/16" Pin Punch
82275	3/16" x 5-1/2" x 5/16" Pin Punch
82278	1/8" x 8" x 3/8" Long Taper Punch
82283	3/16" x 5" x 3/8" Starter Punch
82285	1/8" x 4-1/2" x 5/16" Starter



82304 - 5 Pc. Punch and Chisel Set

Item No.	Description
82270	3/8" x 5" Center Punch
82273	1/8" x 5" x 5/16" Pin Punch
82274	5/32" x 5-1/4" x 5/16" Pin Punch
82275	3/16" x 5-1/2" x 5/16" Pin Punch
82264	1/2" x 6" x 3/8" Cold Chisel



82308 - 4 Pc. Cold Chisel Set

Item No.	Description
82263	7/16" x 5-1/2" x 3/8" Cold Chisel
82264	1/2" x 6" x 3/8" Cold Chisel
82265	5/8" x 6-1/2" x 3/8" Cold Chisel
82266	3/4" x 7" x 5/8" Cold Chisel

82309 - 5 Pc. Pin Punch Set

Item No.	Description
82273	1/8" x 5" x 5/16" Pin Punch
82274	5/32" x 5-1/4" x 5/16" Pin Punch
82275	3/16" x 5-1/2" x 5/16" Pin Punch
82276	1/4" x 7" x 3/8" Pin Punch
82277	5/16" x 7" x 1/2" Pin Punch



82307 - 4 Pc. Long Taper Punch Set

Item No.	Description
82278	1/8" x 8" x 3/8" Long Taper Punch
82279	5/32" x 8-1/2" x 1/2" Long Taper
82280	3/16" x 9" x 1/2" Long Taper Punch
82281	1/4" x 11" x 5/8" Long Taper Punch



84090 - Punch & Chisel Holder



Open Stock - Cold Chisels

Item No.	Description
82261	1/4" x 4-3/4" x 1/4" Cold Chisel
82262	3/8" x 5" x 5/16" Cold Chisel
82263	7/16" x 5-1/2" x 3/8" Cold Chisel
82264	1/2" x 6" x 3/8" Cold Chisel
82265	5/8" x 6-1/2" x 3/8" Cold Chisel
82266	3/4" x 7" x 5/8" Cold Chisel
82267	7/8" x 7-1/2" x 3/4" Cold Chisel
82268	1" x 8" x 7/8" Cold Chisel



- Designed to cut metal such as wrought iron, steel, brass, aluminum, as well as rivets, bolts and nuts



Open Stock - Center Punches

Item No.	Description
82269	1/4" x 4-1/4" Center Punch
82270	3/8" x 5" Center Punch
82271	7/16" x 5-1/2" Center Punch

- Used for marking center lines and pilot drill locations



Open Stock - Pin Punches

Item No.	Description
82272	3/32" x 4-3/4" x 5/16" Pin Punch
82273	1/8" x 5" x 5/16" Pin Punch
82274	5/32" x 5-1/4" x 5/16" Pin Punch
82275	3/16" x 5-1/2" x 5/16" Pin Punch
82276	1/4" x 7" x 3/8" Pin Punch
82277	5/16" x 7" x 1/2" Pin Punch

- Used for final removal to drive out pins and rivets



Open Stock - Long Taper Punches

Item No.	Description
82278	1/8" x 8" x 3/8" Long Taper Punch
82279	5/32" x 8-1/2" x 1/2" Long Taper
82280	3/16" x 9" x 1/2" Long Taper Punch
82281	1/4" x 11" x 5/8" Long Taper Punch

- Used to install and remove pins and shafts and to align holes



Open Stock - Starter Punches

Item No.	Description
82282	5/32" x 5" x 3/8" Starter Punch
82283	3/16" x 5" x 3/8" Starter Punch
82284	1/4" x 6" x 1/2" Starter Punch
82285	1/8" x 4-1/2" x 5/16" Starter Punch
82286	5/16" x 7" x 5/8" Starter Punch
82287	3/8" x 8" x 3/4" Starter Punch

- Designed for both starting and installing pins and rivets

82200 - 18" Rolling Wedge bar



82302 - 7 Pc. Body Tool Set

Item No.	Description
3719	Smooth Faced Bumping Hammer with Square & Round Face
3718	Smooth Faced Cross Chisel Hammer
3720	Cross Faced Shrinking Hammer
3725	Wedge Dolly
3724	General Purpose Dolly
3722	Toe Dolly
3723	Heel Dolly



3718 - Smooth Faced Cross Chisel Hammer



3719 - Smooth Faced Bumping Hammer with Square & Round Face



OPEN STOCK
STRIKING & STRUCK TOOLS

OPEN STOCK

STRIKING & STRUCK TOOLS



3720 - Cross Faced Shrinking Hammer



3722 - Toe Dolly



3723 - Heel Dolly

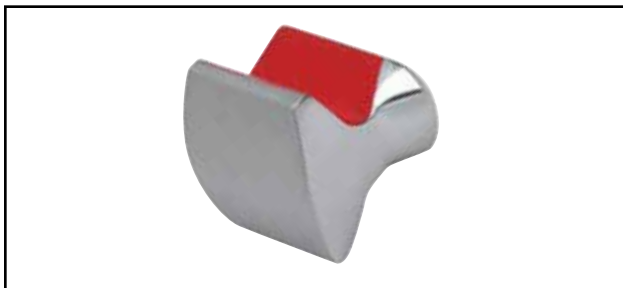

3724 - General Purpose Dolly



3725 - Wedge Dolly

RATCHETING TAPS & DIES



Tap & Die Tools

Ratcheting Tap & Die Sets
Extension Adapter Sets
T-Wrenches

Adapters
Tap Replacement Parts
Die Replacement Parts

RATCHETING TAP AND DIE DRIVE TOOLS

RATCHETING TAPS & DIES



Auto locking feature allows for safe removal of tap adapter

Spring-loaded cap allows for quick-release of large tap adapter

Extension adapters provide access in tight confined areas

Extend the length of tap and die system by combining adapters and any standard 3/8" drive extension.

Works on round and hex shaped dies

Die adapter works with Pass-Thru® Ratchet and Socket System as well as Vortex™ socket accessories.

5° Ratcheting arc with reversible lever eliminates hand over hand turning

Patented Twist Lock Guide System reduces "back walk" of die guard



Products are covered by one or more of the following patents:

- US 6,868,759
- US 7,231,851
- US 7,168,346

82812 - 114 Pc. MASTER Ratcheting Tap and Die Set SAE/METRIC

Item No.	Description
82800	Large Tap and Die Ratcheting "T" Wrench
82801	Large Locking Tap Adapter
82802	Large Hex Die Adapter
3881	Medium Tap and Die Ratcheting "T" Wrench
3883	Medium Tap Adapter
3882	Small Tap Adapter
3884	Medium Hex Die Adapter
82803	Male Extension Adapter - 3/8" Drive
82804	Female Extension Adapter - 3/8" Drive
	Sliding "T" for Adapters
	4mm Hex Key
	5 Screw Extractors
	Metric Thread Gauge
	SAE Thread Gauge



Taps

5/16 - 18 NC taper	1/8 - 28 BSP
5/16 - 24 NF plug	3 x .50 taper
3/8 - 16 NC plug	3 x .60 taper
3/8 - 24 NF plug	4 x .70 taper
7/16 - 14 NC plug	4 x .75 taper
7/16 - 20 NF plug	5 x .80 taper
1/2 - 13 NC plug	5 x .90 taper
1/2 - 20 NF plug	6 x .100 taper
1/8 - 27 NTP	7 x 1.00 taper
4 - 40 taper	1/4 - 19 BSP
6 - 32 taper	9/16 - 18 NF plug
8 - 32 taper	9/16 - 12 NC plug
10 - 24 taper	5/8 - 11 NC plug
10 - 32 taper	5/8 - 18 NF plug
12 - 24 taper	14 x 1.25 plug
1/4 - 20 NC taper	14 x 2.00 plug
1/4 - 28 NF taper	16 x 1.50 plug
8 x 1.25 plug	18 x 1.50 plug
9 x 1.00 plug	18 x 2.50 plug
9 x 1.25 plug	16 x 2.00 plug
10 x 1.25 plug	3/4 - 10 NC plug
10 x 1.50 plug	3/4 - 16 NF plug
11 x 1.50 plug	1/4 - 18 NPT
12 x 1.50 plug	
12 x 1.75 plug	

Hex Dies

4 - 40 taper	16 x 2.00 plug
6 - 32 taper	18 x 1.50 plug
8 - 32 taper	18 x 2.50 plug
10 - 24 taper	1/4 - 19 BSP
10 - 32 taper	9 x 1.25 plug
12 - 24 taper	10 x 1.25 plug
1/4 - 20 NC taper	10 x 1.50 plug
1/4 - 28 NF taper	11 x 1.50 plug
5/16 - 18 NC taper	12 x 1.50 plug
5/16 - 24 NF taper	12 x 1.75 plug
3/8 - 16 NC plug	1/8 - 28 BSP
3/8 - 24 NF plug	14 x 1.25 plug
7/16 - 14 NC plug	14 x 2.00 plug
7/16 - 20 NF plug	3 x .50 taper
1/2 - 13 NC plug	3 x .60 taper
1/2 - 20 NF plug	4 x .70 taper
9/16 - 12 NC plug	4 x .75 taper
9/16 - 18 NF plug	5 x .80 taper
5/8 - 11 NC plug	5 x .90 taper
5/8 - 18 NF plug	6 x 1.00 taper
3/4 - 10 NC plug	7 x 1.00 taper
3/4 - 16 NF plug	8 x 1.25 plug
1/8 - 27 NPT	9 x 1.00 plug
1/4 - 18 NPT	
16 x 1.50 plug	



3887 - 75 Pc. Medium Ratcheting Tap and Die Drive Tool Set SAE/METRIC

Item No.	Description
3881	Medium Tap and Die Ratcheting "T" Wrench
3882	Small Tap Adapter
3883	Medium Tap Adapter
3884	Medium Hex Die Adapter
	Sliding "T" for adapters
	SAE screw pitch gauge
	METRIC screw pitch gauge
	#5 screwdriver

SETS
RATCHETING TAPS & DIES

Taps

1/4 - 20 NC taper	1/4 - 20 NC taper
1/4 - 28 NF taper	1/4 - 28 NF taper
5/16 - 18 NC taper	5/16 - 18 NC taper
5/16 - 24 NF taper	5/16 - 24 NF taper
3/8 - 16 NC plug	3/8 - 16 NC plug
3/8 - 24 NF plug	3/8 - 24 NF plug
7/16 - 14 NC plug	7/16 - 14 NC plug
7/16 - 20 NF plug	7/16 - 20 NF plug
1/2 - 13 NC plug	1/2 - 13 NC plug
1/2 - 20 NF plug	1/2 - 20 NF plug
4 - 40 taper	4 - 40 taper
6 - 32 taper	6 - 32 taper
8 - 32 taper	8 - 32 taper
10 - 24 taper	10 - 24 taper
10 - 32 taper	10 - 32 taper
12 - 24 taper	12 - 24 taper
1/8 - 27 NPT	1/8 - 27 NPT

Hex Dies

1/4 - 20 NC	3 x .50 taper
1/4 - 28 NF	3 x .60 taper
5/16 - 18 NC	4 x .70 taper
5/16 - 24 NF	4 x .75 taper
3/8 - 16 NC	5 x .80 taper
3/8 - 24 NF	5 x .90 taper
7/16 - 14 NC	6 x 1.00 taper
7/16 - 20 NF	7 x 1.00 taper
1/2 - 13 NC	8 x 1.25 plug
1/2 - 20 NF	9 x 1.00 plug
4 - 40 taper	9 x 1.25 plug
6 - 32 taper	10 x 1.25 plug
8 - 32 taper	10 x 1.50 plug
10 - 24 taper	11 x 1.50 plug
10 - 32 taper	12 x 1.50 plug
12 - 24 taper	12 x 1.75 plug
1/8 - 27 NPT	1/8 - 28BSP

3885 - 40 Pc. Medium Ratcheting Tap and Die Drive Tool Set SAE

Item No.	Description
3881	Medium Tap and Die Ratcheting "T" Wrench
3882	Small Tap Adapter
3883	Medium Tap Adapter
3884	Medium Hex Die Adapter
	Sliding "T" for adapters
	Thread gauge
	#5 screwdriver

Taps

1/4 - 20 NC taper
1/4 - 28 NF taper
5/16 - 18 NC taper
5/16 24 NF taper
3/8 - 16 NC plug
3/8 - 24 NF plug
7/16 -14 NC plug
7/16 - 20 NF plug
1/2 - 13 NC plug
1/2 - 20 NF plug
4 - 40 taper
6 - 32 taper
8 - 32 taper
10 - 24 taper
10 - 32 taper
12 - 24 taper
1/8 - 27 NPT

Hex Dies

1/4 - 20 NC
1/4 - 28 NF
5/16 - 18 NC
5/16 - 24 NF
3/8 - 16 NC
3/8 - 24 NF
7/16 -14 NC
7/16 - 20 NF
1/2 -13 NC
1/2 - 20 NF
4 - 40 taper
6 - 32 taper
8 - 32 taper
10 - 24 taper
10 - 32 taper
12 - 24 taper
1/8 - 27 NPT



PATENTED



3886 - 40 Pc. Medium Ratcheting Tap and Die Drive Tool Set METRIC

Item No.	Description
3881	Medium Tap and Die Ratcheting "T" Wrench
3882	Small Tap Adapter
3883	Medium Tap Adapter
3884	Medium Hex Die Adapter
	Sliding "T" for adapters
	Thread gauge
	#5 screwdriver

Taps	Hex Dies
3 x .50 taper	3 x .60
3 x .60 taper	4 x .70
4 x .70 taper	4 x .75
4 x .75 taper	5 x .80
5 x .80 taper	5 x .90
5 x .90 taper	6 x 1.00
6 x 1.00 taper	7 x 1.00
7 x 1.00 taper	8 x 1.25
8 x 1.25 plug	9 x 1.00
9 x 1.00 plug	9 x 1.25
9 x 1.25 plug	10 x 1.25
10 x 1.25 plug	10 x 1.50
10 x 1.50 plug	11 x 1.50
11 x 1.50 plug	12 x 1.50
12 x 1.50 plug	12 x 1.75
12 x 1.75 plug	1/8 - 28BSP

SETS
RATCHETING TAPS & DIES

PATENTED