

Model TCS150ST and TCS150MT

- Carefully selected, intermediate assortment of Xcelite® hand tools
- Contains 23 individual hand tools, popular WP25 Weller® 25 watt soldering iron, 24 Series 99® interchangeable screwdriver / nutdriver blades and handles, XL75 offset ratchet screwdriver set, measuring tape and solder (as listed)
- Case made from rugged Cordura® with heavy-duty zipper and soft leather wrapped handles
- Contains (on outside) 1 pocket on 1 side and 2 smaller pockets on opposite
- Cordura® is a registered trademark of DUPONT
- Size: 17" x 12" X 3"/432mm x 305mm x 76mm



Cat No.	UPC No.	Description
TCS150ST	037103491275	Tool case with tools
TCS150MT	037103491282	Tool case only-NO TOOLS

Cat No.	Description	Qty.	Cat No.	Description	Qty.	Cat No.	Description	Qty.
991, 994R	Handles (regular and ratchet Tee)	1	51NCG	Long nose pliers 6"/152mm	1	S5166	Slotted screwdriver	1
99X5	Extension	1	54CG	4"/102mm Diagonal	1	S3161	Slotted screwdriver	1
9920 - 26,	Allen hex-socket type blades (9)	1	55NCG	5"/127mm Diagonal	1	SX101	Phillips screwdriver	1
99764, 99964			57CG	5 1/2"/102mm Diagonal	1	XL75	5-piece set in see-thru plastic pouch	1
996 - 12	Hex nutdriver blades (7)	1	59NCG	8"/203mm Chain nose pliers	1	600	Combination Dual Nutdriver Handle	1
99250 & 99811	Screwdriver blades	1	86CG	Electronic snips	1	W9210ME	10-foot tape	1
99821 & 99822	Phillips screw blades	1	101S	Wire stripper	1	HS14	Hollow shaft	1
9938	Reamer	1	K22	Electrician's knife	1	HS16	Hollow shaft	1
42H	Seizer	1	R181	Slotted screwdriver	1	8M	Magnetic	1
46CG	Adjustable wrench	1	R3323	Slotted screwdriver	1	10M	Magnetic	1
50CG	Midget slip joint pliers 5"/127mm	1	R184	Slotted screwdriver	1	WP25	Weller 25 watt soldering iron	1
53CG	7"/178mm Utility pliers	1	R3164	Slotted screwdriver	1			

Model TCS200ST



- Fine blending of quality, economy and flexibility
- Contains 10 individual hand tools and 27 Series 99® interchangeable screwdriver/nutdriver blades and handles (as listed)
- Case made from rugged Cordura® and features a heavy-duty zipper and soft leather wrapped handles
- Contains (on outside) 1 pocket on one side and 2 smaller pockets on opposite
- Size: 13 1/2" x 10 1/2" x 2 3/8"/343mm x 267mm x 60mm
- Cordura® is a registered trademark of DUPONT

Cat No.	UPC No.	Description
TCS200ST	037103490421	Tool case with tools

Cat No.	Description	Qty.	Cat No.	Description	Qty.	Cat No.	Description	Qty.
991	Straight handle	1	99811	Slotted screw blade	1	43H	Curved nose seizer 6"/152mm	1
994	Tee handle	1	99250	Slotted screw blade	1	46CG	Adjustable wrench 6"/152mm	1
9920 - 9926	Hex socket screw blades(7)	1	99312	Slotted screw blade	1	51NCG	Long nose pliers 6 1/2"/165mm	1
99764	Hex socket screw blade	1	996	Hex nutdriver blade	1	53CG	Utility pliers 7"/178mm	1
99964	Hex socket screw blade	1	998	Hex nutdriver blade	1	64CG	Diagonal pliers 4"/101mm	1
9938	Reamer	1	9910	Hex nutdriver blade	1	55NCG	Diagonal pliers 5"/127mm	1
99X5	Extension	1	9911	Hex nutdriver blade	1	57CG	Needle nose pliers 5 1/2"/139mm	1
99820	Phillips screw blade	1	9912	Hex nutdriver blade	1	86CG	Electronic snips	1
99821	Phillips screw blade	1	9914	Hex nutdriver blade	1	101S	Wire stripper-cutter	1
99822	Phillips screw blade	1	9916	Hex nutdriver blade	1	K22	Electrician's knife	1
99125	Slotted screw blade	1						

Model TCMG200ST

- Fine blending of quality, economy and flexibility
- Contains 10 individual hand tools and 27 Series 99® interchangeable screwdriver/nutdriver blades and handles (as listed)
- Durable, double skin blow-molded plastic case
- Size: 13 1/2" x 10 1/2" x 2 3/8"/343mm x 267mm x 60mm



Cat No.	UPC No.	Description
TCMG200ST	037103162731	Tool case with tools

Cat No.	Description	Qty.
991	Straight handle	1
994	Tee handle	1
9920 - 9926	Hex socket screw blades(7)	1
99764	Hex socket screw blade	1
99964	Hex socket screw blade	1
9938	Reamer	1
99X5	Extension	1
99820	Phillips screw blade	1
99821	Phillips screw blade	1
99822	Phillips screw blade	1
99125	Slotted screw blade	1

Cat No.	Description	Qty.
99811	Slotted screw blade	1
99250	Slotted screw blade	1
99312	Slotted screw blade	1
996	Hex nutdriver blade	1
998	Hex nutdriver blade	1
9910	Hex nutdriver blade	1
9911	Hex nutdriver blade	1
9912	Hex nutdriver blade	1
9914	Hex nutdriver blade	1
9916	Hex nutdriver blade	1

Cat No.	Description	Qty.
43H	Curved nose seizer 6"/152mm	1
46CG	Adjustable wrench 6"/152mm	1
51NCG	Long nose pliers 6 1/2"/165mm	1
53CG	Utility pliers 7"/178mm	1
64CG	Diagonal pliers 4"/101mm	1
55NCG	Diagonal pliers 5"/127mm	1
57CG	Needle nose pliers 5 1/2"/139mm	1
86CG	Electronic snips	1
101S	Wire stripper-cutter	1
K22	Electrician's knife	1

Tools for Cable Terminals and Connectors

Xcelite® ErgoCrimp Plus® Mechanical Crimping Tools

- ErgoCrimp Plus® are the world's most advanced crimping tools to date
- With a patented design, they deliver up to 50% better mechanical gain than any other kind
- With increased mechanical gain you will get significantly lower handle force which could result in an increase in productivity

These crimping tools have been designed to achieve maximum comfort, reliability, and durability.

Their main features are:

One-Handed Crimping

- The handle force needed for the crimping operation in most tools exceeds 60-70lbs. (27-32Kg)
- The average man and virtually all women cannot make a comfortable one-handed crimp
- Xcelite® crimping tools are designed with such a low handle force requirement that the crimp operation can be performed with only one hand

Crimping Pressure

- The configurations of the crimping nests and indentors are designed to increase the tensile strength of the crimp
- The jaw pressure applies is scientifically calculated for optimum connections

Reliability

- All components are made of high-quality Swedish steel and have been life tested for 50,000 cycles
- Precision manufacturing guarantees a uniform product of high accuracy
- After long wear, it is always possible to check the crimp dimensions with go/no-go gauges, and to adjust for eventual discrepancies by turning the patented excenter adjustment plate

Size

- Size has been minimized to allow single-handed operation and to ensure the tool fits easily into repair kits

Safety

- A ratchet device has been built in to guarantee that the user makes the exact same complete crimp every time
- Should the user start a faulty crimp, a safety release mechanism is built into the ratchet, allowing the user, with one finger, to open the tool before the cycle is complete

Economy

- Because of their considerable advantages in quality, speed, and efficiency, the payoff time for an investment in Xcelite® tools is extremely short

ErgoCrimp Plus® (ECP-000 Frame)
 Length: 10.0"
 Weight: 1.2lbs.

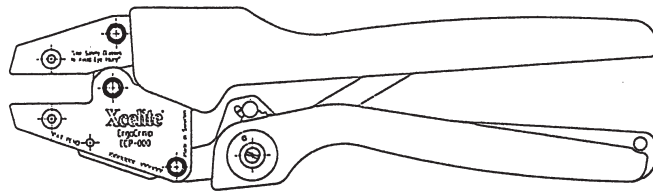

Xcelite

ErgoCrimp Plus® for 22-10 AWG Insulated Terminals and Splices



- ECP000 large ergonomic frame for large hands
- D100 die set for 22-10 AWG red, blue and yellow insulated terminals and splices
- Mechanical gain estimated 50%
- Guaranteed for at least 50,000 cycles
- Variety of die sets available



Cat No.	UPC No.	Packed	Description	Pack Wt.		Shelf Pack
				lb	kg	
ECP100	037103059307	Boxed	ECP000 frame and D100 die set	1.2	0.54	1
D100	037103059345	Boxed	Die set for ECP100	-	-	1

ErgoCrimp Plus® for 22-10 Non-Insulated Terminal Splices

- Die set designed for 22-10 AWG non-insulated terminal splices
- Patented ergonomic design makes this tool easy and comfortable to use
- Lowest possible handle forces required
- High quality construction with tight tolerances
- Superior crimp die design insures the highest quality crimp results
- High strength through-hardened alloy steel and precision manufacturing
- Guaranteed for 50,000 cycles
- Precise eccentric adjustment for consistent performance for life of tool
- Tools can be purchased complete with die set or separately
- Special dies are also available upon request



Cat No.	UPC No.	Packed	Description	Pack Wt.		Shelf Pack
				lb	kg	
ECP101	037103197146	Boxed	ECP101 frame and D101 die set	1.4	0.64	1

Frame only - ErgoCrimp Plus® Crimping Tool

- Large ergonomic frame for large hands
- Length 10"
- Width 2.83"
- Used with D100 through D109 die sets



Cat No.	UPC No.	Packed	Description	Pack Wt.		Shelf Pack
				lb	kg	
ECP000	037103059338	Boxed	ErgoCrimp Plus® crimping tool-large	1.00	0.45	1

Xcelite

ErgoCrimp® Die Set for Insulated Terminals and Splices

- For 22-10 AWG red, blue and yellow insulated terminals and splices
- Precision-machined hardened steel
- Fits ErgoCrimp® and ErgoCrimp Plus® tools



Cat No.	UPC No.	Packed	Description	Pack Wt.		Shelf Pack
				lb	kg	
D100	037103059345	Boxed	Die set			1

ErgoCrimp® Die Set for Non-insulated Terminals and Splices



- For 22-10 AWG non-insulated terminals and splices
- Precision-machined hardened steel
- Fits ErgoCrimp® and ErgoCrimp Plus® tools



Cat No.	UPC No.	Packed	Description	Shelf Pack
D101	037103059352	Boxed	Die set	1

ErgoCrimp® Die Set for RG58, RG59/62 AU BNC/TNC Coaxial Connectors



- For RG 58, RG 59/62 AU BNC/TNC - .213", .255" and .068" hex cavities
- Precision-machined hardened steel
- Fits ErgoCrimp® and ErgoCrimp Plus® tools

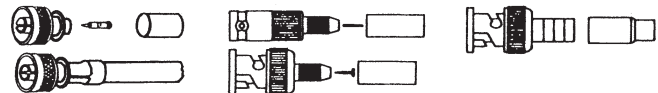

Cat No.	UPC No.	Packed	Description	Shelf Pack
D102	037103059369	Boxed	Die set	1

ErgoCrimp® Die Set for RG59, Belden® 8281 and Belden® 1694A, RG6, 50 and 75 ohm Coaxial Connectors



- For RG 59, Belden® 8281, RG6, 50 and 75 ohm center contacts - .324", .255", .068" and .042" hex cavities
- Precision-machined hardened steel
- Fits ErgoCrimp® and ErgoCrimp Plus® tools
- Belden® is a registered trademark of BELDEN, INC.

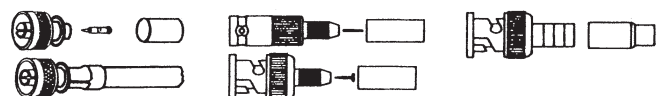

Cat No.	UPC No.	Packed	Description	Shelf Pack
D104	037103059383	Boxed	Die set	1

ErgoCrimp® Die Set for RG174, RG179 BNC/TNC Coaxial Connectors

- For RG 174 BNC/TNC - .178", .128", and .068" hex cavities
- Precision-machined hardened steel
- Fits ErgoCrimp® and ErgoCrimp Plus® tools

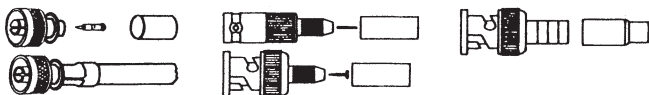

Cat No.	UPC No.	Packed	Description	Shelf Pack
D105	037103059390	Boxed	Die set	1

ErgoCrimp® Die Set for RG8, RG11, RG213, RG216 Coaxial Connectors

- For RG 8, RG 11, RG 213 and RG 216 ethernet N-series, .429"/.213"/.100"/.067" hex cavities
- Precision-machined hardened steel
- Fits ErgoCrimp® and ErgoCrimp Plus® tools

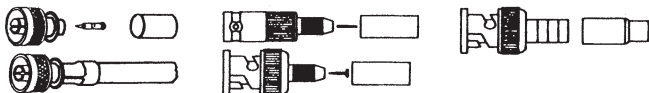

Cat No.	UPC No.	Packed	Description	Shelf Pack
D106	037103059444	Boxed	Die set	1

ErgoCrimp® Die Set for RG6, Belden® 1694A, Twinax, CATV Coaxial Connectors

- For RG 6 CATV "F" connectors - .360"/.324"/.068" hex cavities
- Hex BNC HDTV and cable "F" connectors
- Precision-machined hardened steel
- Fits ErgoCrimp® and ErgoCrimp Plus® tools

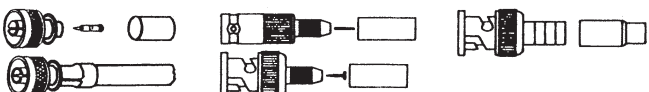

Cat No.	UPC No.	Packed	Description	Shelf Pack
D107	037103059413	Boxed	Die set	1

Xcelite

ErgoCrimp® Die Set for SMA, SMB, SFR, ST, SC Fiber Optic Connectors



- For fiber optic connectors requiring .128"/.151"/.213"/.197"/.178" hex crimps
- Precision-machined hardened steel
- Fits ErgoCrimp® and ErgoCrimp Plus® tools

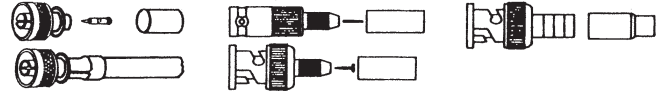

Cat No.	UPC No.	Packed	Description	Shelf Pack
D109	037103059437	Boxed	Die set	1

Modular Plug Die Set for RJ45 Connectors



- Modular plug die set for RJ45 connectors
- 8 position - 8 contact

Cat No.	UPC No.	Packed	Description	Shelf Pack
D110	037103197122	Boxed	Die set	1

Mini-Crimper/Maxi-Crimper Mechanical Crimping Tools

Xcelite® mechanical crimping tools have been designed to achieve maximum comfort, reliability, and durability. Their main features are:

One-handed Crimping

- The handle force needed for the crimping operation in most tools exceeds 60-70lbs. (27-32Kg)
- The average man and virtually all women cannot make a comfortable one-handed crimp
- Xcelite® crimping tools are designed with such a low handle force requirement that the crimp operation can be performed with only one hand

Handle Spread

- Other crimping tools on the market have open handle spreads equal to or greater than 6" at the point where the user places his grip
- This is too great a spread for the average male and female hand
- The Xcelite® mini-crimper has a handle spread of about 3 1/2"/88mm
- It is the smallest spread available in a tool this powerful
- The maxi-crimper, with about 20% more power, still has a handle spread under 4 1/2"/144mm
- Both tools fit comfortably in the average male or female hand
- With just one hand needed to hold the crimping tool, the user is now free to easily locate cable and connector in the jaw of the tool

Crimping Pressure

- The configurations of the crimping nests and indentors are designed to increase the tensile strength of the crimp
- The jaw pressure applies is scientifically calculated for optimum connections

Mini-crimper (MIC)

Length: 7.68"
 Weight: 0.55lbs.
 Open Handle Spread: 3.66"
 Closed Handle Spread: 1.90"
 Max. Crimp Force: 1,600lbs.

Maxi-crimper (MAC)

Length: 8.86"
 Weight: 1.10lbs.
 Open Handle Spread: 4.50"
 Closed Handle Spread: 2.10"
 Max. Crimp Force: 2,200lbs.

Reliability

- All components are made of high-quality Swedish steel and have been life tested for 50,000 cycles
- Precision manufacturing guarantees a uniform product of high accuracy
- After long wear, it is always possible to check the crimp dimensions with go/no-go gauges, and to adjust for eventual discrepancies by turning the patented excenter adjustment plate

Size

- Size has been **minimized** to allow single-handed operation and to ensure the tool fits easily into repair kits

Safety

- A ratchet device has been built in to guarantee that the user makes the exact same complete crimp every time
- Should the user start a faulty crimp, a safety release mechanism is built into the ratchet, allowing the user, with one finger, to open the tool before the cycle is complete

Economy

- Because of their considerable advantages in quality, speed, and efficiency, the payoff time for an investment in Xcelite® tools is extremely short.

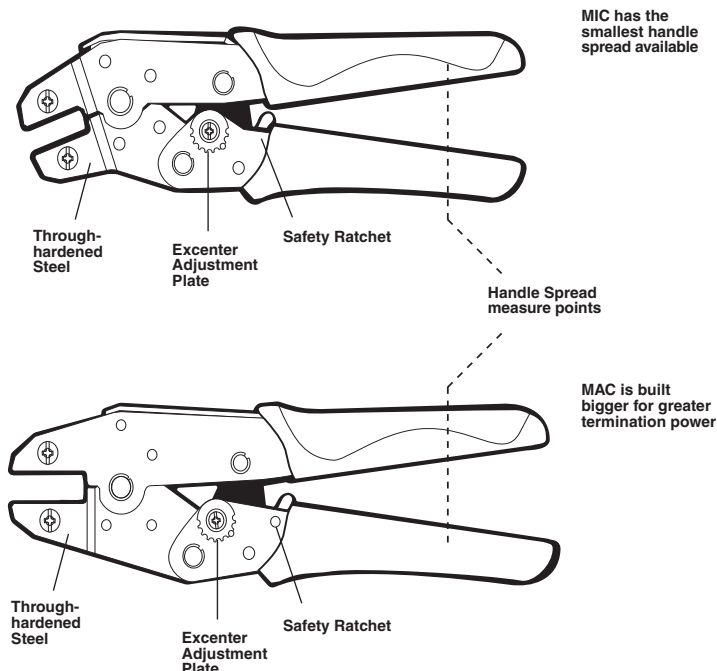

Maxi-Crimper for Insulated Terminals and Splices



- Maxi-Crimper built bigger for greater terminating power
- Crimps 22-10 AWG (.75-6.0mm²) red, blue and yellow insulated terminals and splices (die nests color-coded to AWG specs)
- Incorporates ratchet to ensure a full-cycle complete crimp every time
- Crimps exceed UL® standards for most terminals from AMP, 3M, T & B and many others

Cat No.	UPC No.	Packed	Description	Pack Wt.		Shelf Pack
				lb	kg	
MAC2210	037103489180	Boxed	Maxi-crimper tool	1.1	0.5	1
D2210	037103490186	Boxed	Die set for MAC2210	-	-	1

Mini-Crimper for Open Barrel D-subminiature Contacts

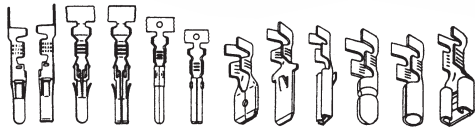

- Mini-Crimper smallest professional crimp tool of its kind
- Universal tool designed to crimp a wide range of open-barrel and D-subminiature contacts 30-20 AWG
- Versatile tool for pins, sockets, disconnects and other open-barrel contacts from AMP, MOLEX, ITT Cannon and others
- Incorporates ratchet to ensure a full-cycle complete crimp every time

Cat No.	UPC No.	Packed	Description	Pack Wt.		Shelf Pack
				lb	kg	
MIC3020BL	037103490391	Boxed	Mini-crimper tool	0.55	0.25	1

32 AWG to 10 AWG Combination, Self-adjusting Wire Stripper



- Tool capable of stripping wires from 32 AWG to 10 AWG without adjustment
- Widest stripping capacity of any tool of its type
- Easily interchangeable stripping cassettes enables precision stripping
- Strips a wide range of insulation types, PVC to PTFE with just one tool. Tested to over 150,000 cycles
- The ergonomic design is lightweight, strong, and comfortable
- The tool issuitable for production of field service work
- Fine insulation can be stripped without damage to the conductor
- Low friction moving handle optimized grip span, and angled head

Cat No.	UPC No.	Packed	Description	Shelf Pack
SAS3210	037103197306	Boxed	Self-adjusting wire stripper	1

Interchangeable Replacement Blade for SAS3210 Combination Wire Stripper

- Interchangeable replacement blade for SAS3210 combination wire stripper
- Capable of stripping wires from 34 to 8 AWG without adjustment



Cat No.	UPC No.	Packed	Description	Shelf Pack
SAS3210RB	037103197276	Boxed	Interchangeable replacement blade	1

Interchangeable Replacement Blade for SAS3210 Combination Wire Stripper

- Interchangeable replacement blade for SAS3210 combination wire stripper
- Capable of stripping Teflon® insulation from 32 AWG to 10 AWG



Cat No.	UPC No.	Packed	Description	Shelf Pack
SAS3210TRB	037103197283	Boxed	Interchangeable replacement blade	1

Economical Coaxial Wire Stripper - Pre-adjusted for RG59 & RG6



- Tool specially designed to quickly and easily strip RG 59 and RG 6 cables for CATV “F” connectors
- Built-in stop (no adjustments needed)
- Replaceable blade cassette lasts 1,000-2,000 strips
- Convenient built-in belt clip
- Full operating instructions listed on back of blister card

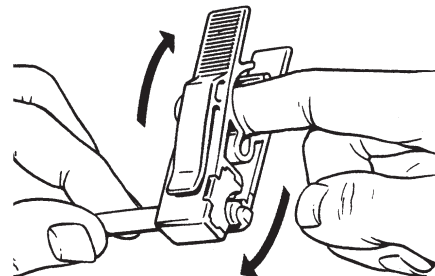
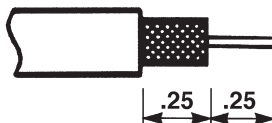

Cat No.	UPC No.	Packed	Description	Pack Wt.		Shelf Pack
				lb	kg	
2CSKCATV	037103045324	Carded	For RG59 and RG6	1/4	6	3
CATVC	037103045331	Boxed	Cassette, spare blades for 2CSKCATV	1/4	6	3

Cable Jacket Stripper, 0.43" Maximum Diameter

Xcelite



CJS100



- **Precise:** Fine adjustability and repeatability assured by 9 position blade cutting depth adjustment
- **Easy to use:** Simply squeeze together, insert cable, release and rotate once, remove from cable and pull off scrap insulation
- **Safe:** Smooth, rounded, pocketable, lightweight design. No exposed blades. Replacement blades are encased in a plastic cassette
- **Flexible:** Strips the jacket from most cables up to 0.43" (11 mm) in diameter
- **Durable:** Tested to over 50,000 cycles
- **Economical:** Replaceable blade (p/n CJS100B)

Cat No.	UPC No.	Packed	Description	Shelf Pack
CJS100	037103197061	Carded	Cable jacket stripper	1
CJS100B	037103197122	Boxed	Replacement blade	1

Round Cable Stripper, .178" - 1.57" Diameter

- By rotating the body of the tool, the blade can be fixed in any one of three positions to provide:

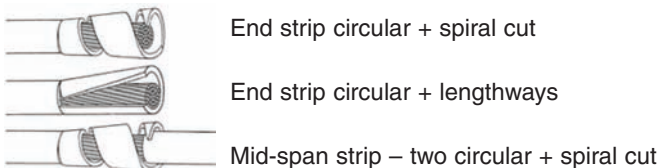
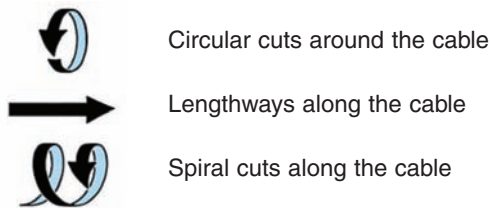

- Unique to this type of tool, the CJS200 features two interchangeable cable retention guides giving it an incomparable stripping capacity of 0.18" to 1.57" (4.5-40 mm) in one tool. Both cable guides are included with each tool. The CJS200 can replace two or more similar products in the toolbox
- Easy to use:** Positive locking positions for circular, lengthways, and spiral cuts
- No special tools required to interchange cable guides
- Safety strap can be attached to the eyelet at the base of the tool to prevent accidental dropping
- Ergonomic:** The well-balanced design features rests for thumb, first, and little fingers to ease in raising of the cable retention guides
- Durable:** Tested to over 100,000 cycles
- Economical:** Replacement blade available (p/n CJS200B). Can be stored in the tool body

Cat No.	UPC No.	Packed	Description	Shelf Pack
CJS200	037103197085	Carded	Round cable stripper	1

Accessories for CJS200 Round Cable Stripper

- CJS200B:** Replacement blade for CSJ200 round cable stripper
- CJS200LG:** Large cable guide for CJS200 round cable stripper
- CJS200SG:** Small cable guide for CJS200 round cable stripper



CJS200B



CJS200SG



CJS200LG

Cat No.	UPC No.	Packed	Description	Shelf Pack
CJS200B	037103197092	Boxed	Replacement blade for CSJ200 round cable stripper	1
CJS200LG	037103197108	Boxed	Large cable guide for CSJ200 round cable stripper	1
CJS200SG	037103197115	Boxed	Small cable guide for CSJ200 round cable stripper	1

Xcelite

Coaxial Wire Stripper - Full Kits and Pre-adjusted Models

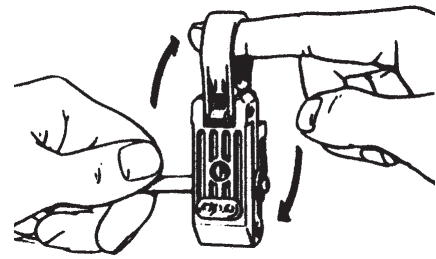
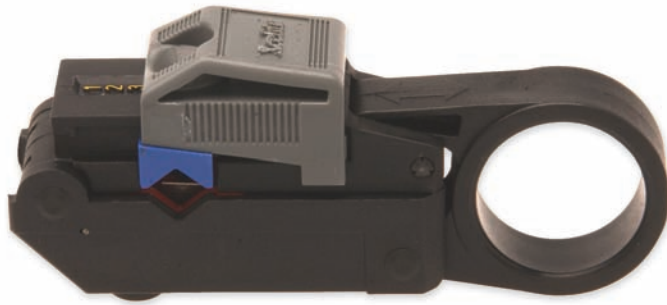

- Fastest accurate coax-stripping system
- Coaxial cable from .10" to .30" (1.87-7.6mm) in thickness (RG 178 up to RG 6) stripped in seconds
- Also removes dielectric, braid and outside insulation
- Xcelite® system available with different color-coded cassettes designed to meet exact stripping specifications
- Cassettes changed in seconds
- Available in full kits for users of many different cable sizes
- Special, pre-adjusted models or cassettes with special strip lengths made upon request

Full Kits - Coaxial Wire Stripper

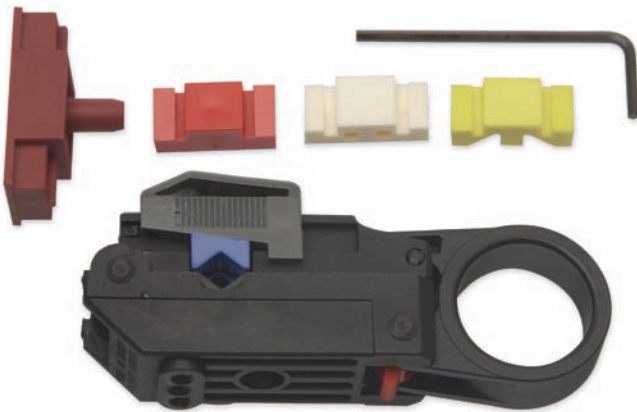

3CSKWH

- Full kit designed for user who strips many different size cables (from .1" to .3"/2.5-7.6mm)
- Contains cassette indicated, all 4 Xcelite® V-Blocks, hex wrench and instruction sheets covering most possible applications
- 3-step models not recommended for cable with hollow dielectric (RG 62) or foam dielectric (use 2-step models instead)
- Cable O.D. range: .10"-.30" (2.5-7.6mm), RG 174 to Belden® 8281 or RG 6

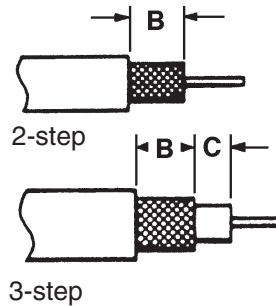

Kit Cat No.	UPC No.	Type	Packed	Cassette Cat No. & Color	Cassette UPC No.	Blade Spacing				Cover Strip Length Specs.				Shelf Pack
						(B)		(C)		(B)		(C)		
						in	mm	in	mm	in	mm	in	mm	
2CSKR	037103489456	2-step	Pouched	2CR red	037103489493	0.24	6.0	-	-	7/32-1/4	5.6-6.3	-	-	1
2CSKB	037103489470	2-step	Pouched	2CB blue	037103489616	0.27	6.8	-	-	1/4-9/32	6.3-7.1	-	-	1
2CSKY	037103489463	2-step	Pouched	2CY yellow	037103489609	0.47	12.0	-	-	7/16-1/2	11.1-12.7	-	-	1
3CSKBR	037103489432	3-step	Pouched	3CBR brown	037103489579	.328	8.3	.109	2.7	5/16-11/32	7.9-8.7	1/16-7/64	1.6-2.8	1
3CSKGN	037103489449	3-step	Pouched	3CGN green	037103489586	.235	6.0	.235	6.0	7/32-1/4	5.6-6.3	13/64-1/4	5.1-6.3	1
3CSKWH	037103489975	3-step	Pouched	3CWH white	037103489986	.266	6.7	.063	1.6	1/4-17/64	6.3-6.7	1/16-3/32	1.6-2.4	1

Note: 3-STEP models are not recommended for cable with hollow dielectrics (RG 62) or foam dielectrics. Use 2-STEP models instead. Cable O.D. range: .10"-.30" (2.5-7.6mm) e.g. RG174 to Belden® 8281 or RG6.

Cassettes

- The cassette determines the strip dimension that your stripper will give
- New tool body design allows all cassettes to be used in any 2 step or 3 step full kit or pre-adjusted model
- Cassettes can be interchanged in seconds in the tool body

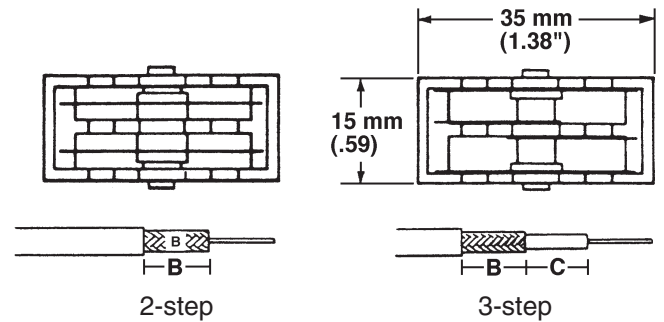

Cassette Cat No. & Color	Cassette UPC No.	Type	Packed	Blade Spacing				Cover Strip Length Specs.				Shelf Pack
				(B) in	(B) mm	(C) in	(C) mm	(B) in	(B) mm	(C) in	(C) mm	
2CR red	037103489493	2-step	Carded	0.24	6.0	-	-	7/32-1/4	5.6-6.3	-	-	1
2CB blue	037103489616	2-step	Carded	0.27	6.8	-	-	1/4-9/32	6.3-7.1	-	-	1
3CBR brown	037103489579	3-step	Carded	0.328	8.3	0.109	2.7	5/16-11/32	7.9-8.7	-	-	1
3CGN green	037103489586	3-step	Carded	0.235	6.0	0.235	6.0	7/32-1/4	5.6-6.3	-	-	1

Belden® is a registered trademark of Belden, Inc.

Cat. No.	Page	Cat. No.	Page	Cat. No.	Page	Cat. No.	Page
10	17	44CGV	66	9922	1, 28, 36	99832	27
100X	63, 70	46CG	31, 66, 70	9922BP	28, 34	998M	26, 33
100XV	63	46CGV	66	9923	1, 28, 36	998MM	26, 37
101S	63	48CG	66	9923BP	28, 34	998XTD	29
101SV	63	48CGV	66	9924	1, 28, 36	999	26, 37
103S	64	4MM	19	9924BP	28, 34	99964	1, 28, 33, 36
103SV	64	50CG	63	9925	1, 28, 36	99964BP	28, 34
104CG	64	50CGV	63	99250	27, 31, 32, 33, 37	999MM	26, 37
104CGV	64	51NCG	62, 70	99250V	27	99K	32
105CG	64	51NCGV	62	9925BP	28, 34	99MP	33
105CGV	64	52NCGV	31, 62	9925XTD	29, 35	99MPK	33
105SCGV	64	54CG	60	9926	1, 28, 33, 36	99PA	30, 33
10M	19	54CGV	60	9926BP	28, 34	99PA50	33
10MM	19	55MM	19	9927XTD	29, 35	99PAV	30
10V	17	55NCG	31, 61	993	25, 31	99PR	32
11	17	55NCGV	61	9930XTD	29, 35	99PS40	36
1178D	58	57CG	62	99312	27, 33	99PS40BP	34
1178M	58	57CGV	62	9938	29, 31, 33	99PS40BPV	34
12	17	59NCG	62	994	25, 33	99PS40V	36
127TB	20	5MM	19	9945MM	37	99PS41MM	36
134CG	60	6	17	994MM	26, 37	99PS41MMBP	35
13MM	20	600	16	994R	25	99PS50	37
14	17	600V	16	994V	25	99PS50V	37
147TB	20	64CG	61	9955MM	26, 37	99PS51MM	37
157	20	64CGV	61	995MM	26, 37	99PS60	38
170D	58	66NCG	61	996	26, 31, 32, 33, 37	99S10	26, 31, 33
170M	58	66NCGV	61	9961	2, 29, 33, 38	99S12	26, 31, 33
175D	58	76C	70	9962	2, 29, 38	99S8	26, 31, 33
175M	58	7MM	19	9963	2, 29, 38	99SM	31
177	20	8	17, 70	9964	2, 29, 38	99SMK	31
18120	6	80V	66	9965	2	99SMX	31
2178D	58	86CG	65	9966	2, 29, 38	99SPC	32
2178M	58	86CGV	65	9967	2, 29, 38	99X10	30, 31
25	14	8M	19	9969	2, 29, 33, 38	99X10V	30
2CB	93	8MM	19	996MM	26, 37	99X5	30, 33, 34, 35, 36, 37, 38
2CR	93	991 25, 31, 32, 33, 34, 35, 36, 37, 38		996XTD	29	99XTD7	35
2CSKB	92	9910	26, 37	997	26, 37	C1K	56
2CSKCATV	90	9910M	26	9971MM	28, 36	CATVC	90
2CSKR	92	9910MM	26, 37	9972MM	28, 36	CJS100	90
2CSKY	92	9910XTD	29, 32, 35	9973MM	28, 36	CJS100B	90
32H	63	9911	26, 37	9974MM	28, 36	CJS200B	91
33220	6	9911MM	26, 37	9975MM	28, 36	CJS200LG	91
33HV	63	9912	26, 37	99764	1, 28, 33, 36	CJS200SG	91
378D	59	99125	27, 33	99764BP	28, 34	CK20	15
378M	59	9914	26	9976MM	28, 36	CK23	15
378SMD	59	9915XTD	29, 32, 35	9977MM	28, 36	CK3	16
378SMM	59	9916	26, 31, 32, 33	997MM	26, 37	CN255	49
3CBR	93	991R	25	998	26, 32, 37	CN255G	49
3CGN	93	991V	25	99811	27, 31, 32, 33, 37	CN255V	49
3CSKBR	92	992	25	99811V	27	CN54G	52
3CSKGN	92	9920	1, 28, 33, 36	99820	27, 32, 33	CN55G	52
3CSKWH	92	9920BP	28, 34	99821	27, 31, 32, 33, 37	CN7776	55
413MM	21	9920XTD	29, 35	99821V	27	CR1	15
42HV	63	9921	1, 28, 36	99822	27, 31, 32, 33, 37	CR1V	15
43HV	63	9921BP	28, 34	99822V	27	CR2	15
44CG	66			99831	27	CR2V	15

Cat. No.	Page	Cat. No.	Page	Cat. No.	Page	Cat. No.	Page
D100	82, 83	L4V	53	MS545JV	44	R181V	6
D101	84	L8	18	MS545V	44	R182	7
D102	84	L8M	19	MS549J	40, 42	R182V	7
D104	84	L8MV	19	MS549JV	42	R183	6, 7
D105	85	LC665J	40, 48	MS54J	42	R183V	6, 7
D106	85	LN11	13	MS54V	42	R184	7, 70
D107	85	LN15MM	12	NN54	54, 56	R184V	7
D109	86	LN20	1, 12	NN542	53	R186	7
D110	86	LN20BP	13	NN54G	54	R186V	7
D2210	88	LN21	1, 12	NN54GV	54	R188	7
DN54G	53, 56	LN21BP	13	NN54V	54	R188V	7
DN54GV	53	LN21V	12	NN55	54	R31610	7
EC54J	40, 48, 56	LN22	1, 12	NN55G	54	R3163	7
ECP000	83	LN225	49	NN55V	54	R3164	7
ECP100	82	LN22BP	13	NN7776	55	R3164V	7
ECP101	83	LN22V	12	NN7776G	55	R3166	7
EGA54J	40, 48	LN23	1, 12	NN7776V	55	R3166V	7
ELN54	50	LN23BP	13	P1	21, 23	R3168	7
ELN54G	50	LN23V	12	P10	22, 23	R3322	6
EMS54	40, 43	LN24	1	P12S	9, 70	R3322V	6
EMS543J	40, 44	LN25	1, 12	P12S20	6	R3323	6
EMS545J	45	LN25BP	13	P12SV	9	R3323V	6
EMS549J	40, 43	LN25MM	12	P18	1	R3324	6
ENN54	54	LN26	1	P19	1, 23	R3324V	6
FSD1	16	LN27	1	P20	1, 23	R388	7
FSD1V	16	LN28	1	P21	1	R5164	7
GA54J	40, 47	LN28BP	13	P22	1, 23	R5166	7
GA54JV	47	LN2MM	12	P23	1, 23	R5168	7
HS10	18	LN3MM	12	P24	1	R5323	7
HS10V	18	LN4MM	12	P3321	21	R5324	7
HS11	18	LN54	49, 56	P35MM	22	R5325	7
HS11V	18	LN542	50	P3MM	22	RB1	15
HS12	18	LN54G	50	P4	22	RB2	15
HS12V	18	LN54GV	50	P5	22	RN54	52
HS14	18	LN54V	49	P6	22, 23	S141	8, 70
HS14V	18	LN55	51	P764	1	S1415JS	40, 46
HS16	18	LN55V	51	P8	22, 23	S144	8
HS16V	18	LN764	1, 12	P964	1	S146	8
HS18	18	LN764BP	13	PS120	22	S2K	59
HS18V	18	LN774512	54	PS120V	22	S3161	8
HS6	18	LN775512	55	PS121MM	22	S3163	8
HS618	21	LN775512G	55	PS130	23	S3164	8
HS7	18	LN775512V	55	PS130V	23	S3166	8
HS8	18	LN8MM	13	PS88	21	S3812	8
HS8V	18	LN964	1, 12	PS88V	21	S388	8
HS9	18	LN964BP	13	PS89	23	S424JS	40, 45
HS9V	18	LN9BP	14	PS89V	23	S424JSV	45
K22	66	M60	24	PS90MM	24	S475JS	45
K22V	66	M60V	24	R1410	7	S475JSV	45
L10	18	MAC2210	88	R144	7, 70	S5164	8
L10M	19	MIC3020BL	88	R144V	7	S5166	8
L10MV	19	MS54	40, 42, 56	R146	7	S5168	8
L11	18	MS543J	40, 43	R146V	7	S54KS	40, 46
L12	18	MS543JV	43	R148	7	S54N	40, 46
L4	53	MS545	40, 44	R181	6	S54S	40, 46
L4G	53	MS545J	40, 44	R1810	7	S54SV	46

Cat. No.	Page	Cat. No.	Page	Cat. No.	Page	Cat. No.	Page
S55KS	40, 47	XL75V	65				
S55N	40, 47	XN100	68				
S55S	40, 47	XN100B	68				
SAS3210	88	XN200	68				
SAS3210RB	89	XN210	68				
SAS3210TRB	89	XN300	68				
SD3V	11	XNB101	69				
SDR11	8	XNB103	69				
SDS44	9	XNB103B	69				
SDX22	11	XNB105	69				
SN54	40, 51, 56	XNB201	69				
SN55	40, 51	XNB203	69				
SN55V	51	XNB205	69				
SRX33	11	XNB301	69				
SX101	9	XNB305	69				
SX102	9	XNS100	69				
TA2	21, 22, 23, 24	XP1	4				
TC100MT	72	XP1B	4				
TC100ST	72	XP1CHG	4				
TC55	40, 51	XP600	4				
TCA100ST	73	XP700	5				
TCA150ST	76	XPE500	5				
TCMB100MT	74	XPE700	5				
TCMB100MTW	71	XPTX600	4				
TCMB100ST	74	XSST3	67				
TCMB100STW	71	XSST3CV	67				
TCMB150MT	77	XSST3V	67				
TCMB150ST	77	XSST4V	67				
TCMG150MT	78	XSST5V	67				
TCMG150ST	78	XSST7V	67				
TCMG200ST	81	XST100	10				
TCS100ST	75	XST100V	10				
TCS150MT	79	XST101	10				
TCS150ST	79	XST1010	10				
TCS200ST	80	XST101V	10				
TKX11	70	XST102	10				
TSD1V	17	XST1020	10				
W9210ME	70	XST102V	10				
X100	10	XST3	11				
X101	10, 70	XST5	11				
X1010	10	XTD10	3, 11				
X101V	10	XTD10XL	11				
X102	10	XTD15	3, 11				
X1020	10	XTD15XL	11				
X102V	10	XTD20	3, 11				
X103	10	XTD25	3, 11				
X108	10	XTD27	3, 11				
X108V	10	XTD30	3, 11				
XHT412	67	XTD6	11				
XHT434	67	XTD6V	11				
XHT600	67	XTD8	3, 11				
XHT612	67	XTD8V	11				
XHT678	67						
XHT700	67						
XL70	65						
XL75	65						

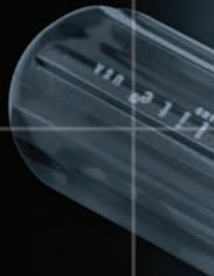

Cooper Hand Tools
World Headquarters
1000 Lufkin Road Apex, NC 27539

Telephone919-387-0099
Fax919-387-2614

Customer Service U.S.:

Telephone:
North866-907-9706
South866-907-9718
Midwest.....866-907-9715
West/SW866-907-9716
Hardware919-362-1670

Fax:
North800-854-5137
South800-854-5139
Midwest.....800-854-5138
West/SW800-546-7312
Hardware877-387-0415
Export919-387-2402

Customer Service Canada:

Cooper Hand Tools-Canada
164 Innisfil Street
Barrie, Ontario
Canada L4N 3E7

Phone:705-728-5564
Fax:800-403-8665



Campbell® CaulkMaster® Crescent® Diamond® Erem® Kahmetics® Lufkin®
Nicholson® Plumb® H.K.Porter® Weller® Wire-Wrap® Wiss® Xcelite®