



DESCRIPTION:

AUTOMA Disco Check Valve is a device that allows fluids to flow through in only one direction. It is designed to prevent backflow of fluids for example when the pump is shut-off. It can be installed in horizontal or vertical positions in the piping system.

SPECIFICATION:

- Investment Casting CF8M
- Face to face according to DIN3202-K4
- Wafer type suits universal flange PN, JIS and ANSI-150/300
- Can be installed vertically or horizontally
- Maximum pressure 40bar for DN15 to DN100
- Maximum pressure 25bar for DN125 to DN250
- Maximum temperature up to 250°C

APPLICATION:

- Water, oil and neutral gases
- Hot water and steam

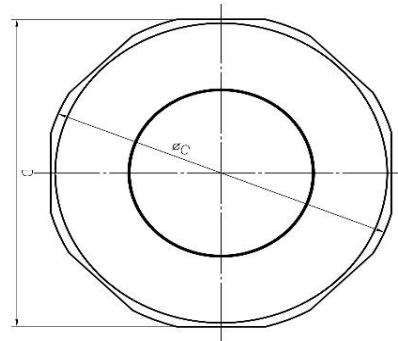
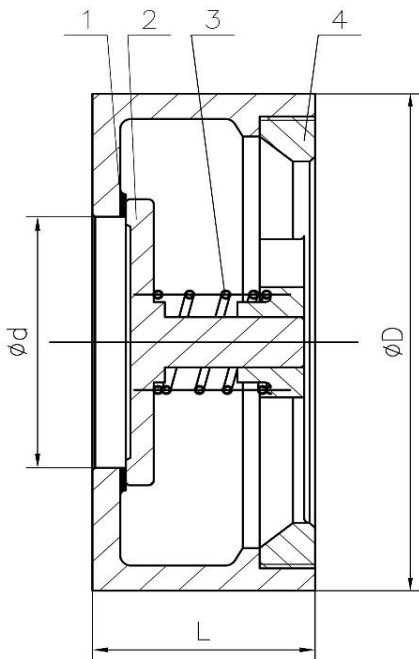

MATERIAL LIST:

PART NAME	MATERIAL
1. Body	A351 CF8M
2. Disc	A351 CF8M
3. Spring	SS316
4. Cap	A351 CF8M

DIMENSIONS (mm):

SIZE	1/2"	3/4"	1"	1-1/4"	1-1/2"	2"	2-1/2"	3"	4"	5"	6"	8"	10"	12"
DN (d)	15	20	25	32	40	50	65	80	100	125	150	200	250	
L	16	19	22	28	32	40	46	50	60	90	106	140	146	
C	51	61	70	79	88	108	125	135	161	196	228	270	328	
D	46	56	65	74	84	102	121	131	156	190	220	270	328	

The specification and dimensions are subject to change without prior notice!