

Operation Instruction

1. GENERAL

- 1 Channel induction loop detector
- Most suitable for barrier gate controls
- Parking and traffic application
- Vehicle traffic countings (optional)
- 1 Year limited warranty

Main Features :

Upon power on or output settings are changed, it will start to self-learn. The plastic case can be fit neatly by aligning the protruded rod and cavity. Output function and timing can be adjusted by DIP switch settings. Present and after-pulse relay output functions are available.

2. USAGE AND FUNCTIONS GUIDE

Upon power up, the detector will self-learn in about 1s. During self-learning mode, the green LED will flash, the red LED is off. During this period the loop must not be covered by vehicle. Once it has self-learned, the green LED will stop flashing and on all the time. Whenever vehicle is over the loop coil, the red LED will light up.

3. DIP SWITCH FUNCTIONS

DIP 1 & 2 are for sensitivity. DIP 3 sets the Relay 1 on time. DIP 4 is to set Relay 2 for present or pulse mode. DIP 5 sets instant or delay mode. DIP 6 sets frequency level. More detailed description of the DIP switches is explained in the following sections.

4. OPERATIONAL FREQUENCY

To prevent interference between 2 units at close proximity, set DIP 6 of each for different setting as shown.



5. SENSITIVITY SETTINGS

Sensitivity is done by DIP 1 (s) & DIP 2 (s) as shown in below drawing. If the detector's response need increasing, set switches to the right.

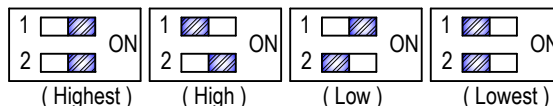

6. LED INDICATION

Green LED	Red LED	Meaning
OFF	OFF	No incoming power supply
FLASH	OFF	Self-learning mode
ON	OFF	Vehicle not within sensing range
ON	ON	Vehicle within sensing range
OFF	ON	Loop coil is not detected

7. OUTPUT RELAY OPERATIONS

Terminal 15/16 (Relay 1) : If S1 (internal PCB jumper) set to OPEN, relay contact is shorted when loop is covered and open when not covered. If S1 is set to CLOSE, relay contact is open when loop is covered and shorted when not covered.

Terminal 25/28 (Relay 2) : Contact can be present or after-pulse mode. If DIP 4 set to OFF, it is in After-Pulse mode (1s on time once vehicle left the loop). If DIP 4 set to ON, the contact will be in present mode.

8. HOLDING AND DELAY TIME SETTINGS

DIP 3 (h) is in OFF position, present mode will hold for 5 minutes even if the loop is still covered by vehicle ; it is used for resetting purpose. If DIP 3 is set to ON, the present mode is on as long as vehicle is present. DIP 5 sets instant or delay closing mode. If DIP 5 sets to OFF, it is for instant mode (barrier arm closes immediately). If DIP 5 is set to ON, there is a delay of 2s (barrier arm closes after vehicles left the loop 2s later) ; it is used for safety purpose.

9. CONNECTIONS

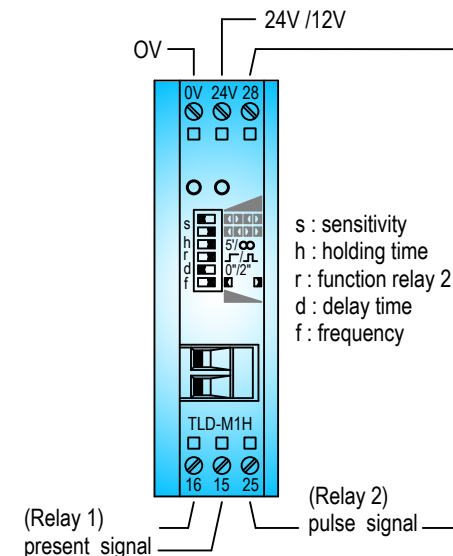

Technical Data :

Power supply	12V - 24V ac/dc ± 5% max. 3W
Self - learning	1 to 2 seconds
Humidity	max. 95% not condensing
Loop inductance	50-800 μH, recommended 100-300 μH
Frequency range	20 - 130 KHz in 2 steps
Sensitivity	ln 4 steps
Holding time	5 minutes or infinity
Operating temperature	-20°C to +70°C
Dimensions	81H x 25W x 100L mm
Connections	screw terminals (power supply, relays) binder plug (loop connection)