



INSTALLATION MANUAL (AAC BLOCK)

ALAM-CON SDN BHD



TABLE OF CONTENTS

PAGES	01	General Requirement
PAGES	02	ACON AAC Block Wall Installation Guidelines
PAGES	04	Standard Details for ACON AAC Block Wall
PAGES	05	Lintel and Opening
PAGES	06	Chases in ACON AAC Wall
PAGES	07	Gable End and Parapet Wall
PAGES	08	Finishes Coating
PAGES	10	Stiffener Requirements
PAGES	12	Application of Fiber Glass Reinforcing Tape
PAGES	13	Steel Structure Support

General Requirement

1. Thick bed levelling mortar should be nominally 10mm to 30mm. Allow levelling mortar to set at least for minimum of 4-Hour before commencing the remaining block courses.
2. Provide 10mm to 20mm gap between block wall and column/ stiffener.
3. Allow a minimum of 20mm clearance (Max. of 50mm) between block wall and beam/ slab soffit.
4. Use Cement-Sand Mortar with a mix ratio of 1:3 to 1:5 for filling the clearance gaps, thick bed levelling, and patching the damage wall.
5. AAC block must be installed in a stretcher bond pattern with a minimum 100mm block overlap. The blocks are typically cut to 300mm length to achieve half of joint offset.
6. Interface of block wall and column/ stiffener, fix L-Bracket at 600mm centres, first and last courses.
7. Interface of block wall and beam/ slab soffit, fix L-Bracket at 1200mm centres, first and last block.
8. Ensure 2mm to 3mm thickness of Thin Bed Adhesive at vertical and horizontal of block joints. Joints must be completely filled with adhesive.
9. Clean any excess adhesive within hours after block laying.
10. Where required by design, clearance gaps (block wall to soffit) can be adjusted to suit and /or filled with compatible sealant instead of cement-sand mortar.
11. Ensure the first block course is true and level before proceeding to the subsequent courses. Use suitable tools such as spirit level, laser levelling, alignment instrument, etc.
12. Allow wet blocks to dry before installation.
13. Minimum block length allowed to be installed within each block course is 100mm.
14. Freshly erected block wall must be protected from rain or water prior to curing.
15. Check the level and alignment of subsequent courses occasionally.
16. Provide vertical RC stiffener at maximum 4m centres.
17. Provide horizontal stiffener if block wall exceeds 4.5m in height.
18. RC beams, columns, slabs, and stiffeners must be designed by qualified Engineer.
19. When used externally and subjected to wind load, stiffeners spacing should be reduced to Engineer's Specification.

Minimum and Recommended AAC Block Thickness

ACON AAC Blocks are available in various thickness, ranging from 50mm and 75mm up to 200mm thick. Please refer to the table below for the minimum thickness recommendations in AAC Block Wall.

AAC Block Thickness	Applications
50mm and 75mm	Encasement or Box-up Wall
100mm	Internal Wall
125mm	External Wall
150mm	Internal or External Wall <i>*M&E Rooms, Separating Wall with 24-hrs Air Conditioning Room, etc.</i>
200mm	Party Wall

Thus, if thicker block is required over the recommended thickness, it is up to designer or owner of the building to choose according to suitability as well as the intended applications. It is necessary to get approval to ensure all the design criteria such as fire rating, sound insulation, thermal insulation, and other properties are satisfied.

STEP 1 PREPARATION FOR LEVELLING

Notes: 1. The set-up for vertical and horizontal alignment may use alignment string or laser level line.

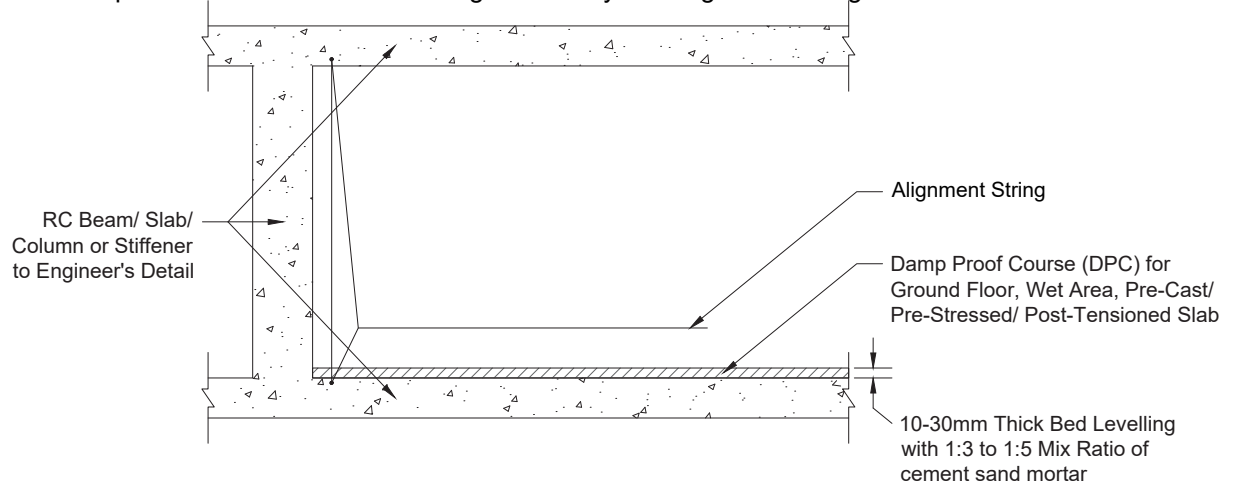

STEP 2 FIRST COURSE OF ACON AAC BLOCK

Notes: 1. To ensure that the Floor Level is even in order to maintain the Thick Bed Levelling constantly.
2. Before commence block work, check reference points such as soffit beam/ slab level, lintel level, and be sure where to terminate the last course.

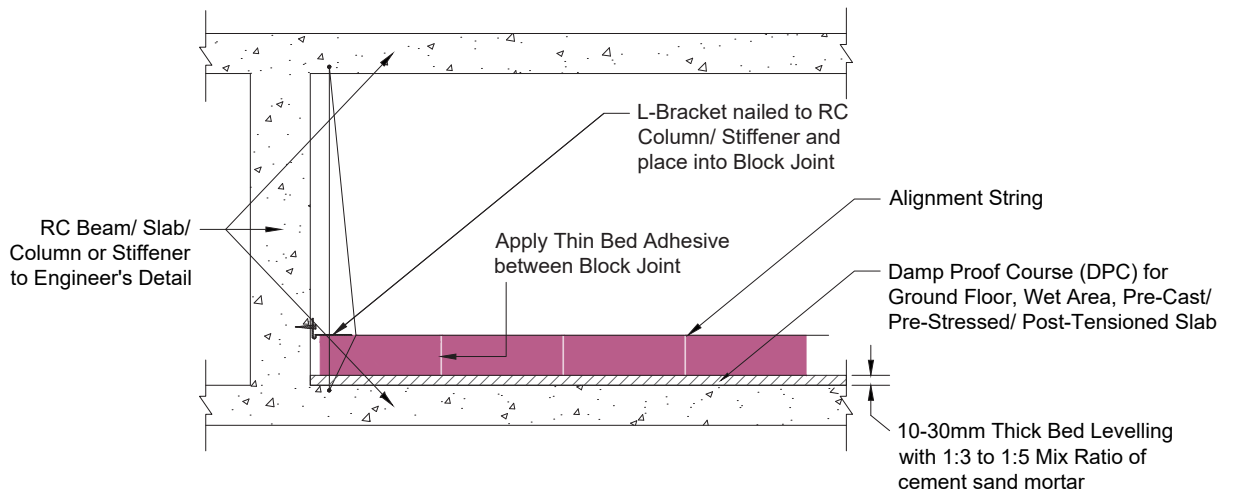

STEP 3 SUBSEQUENT COURSES OF ACON AAC BLOCK

Notes: 1. To ensure that the first course has properly cured and stable before proceeding for the next subsequent courses.
2. The block joint must be completely filled with ACON Thin Bed Adhesive and without any void or space passes through the joint.

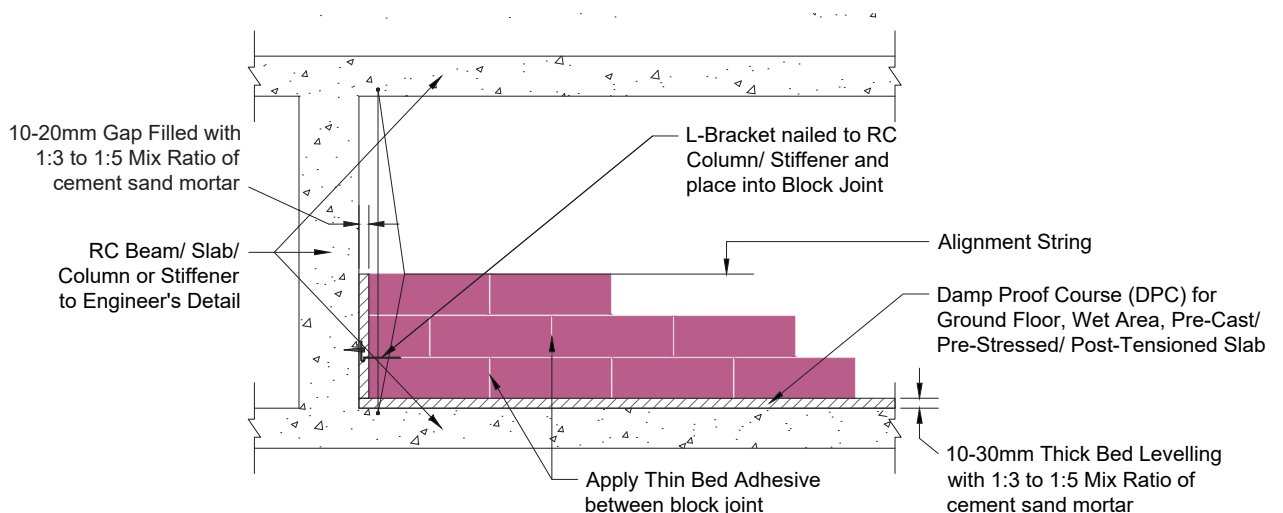

STEP 4 FINAL COURSE OF ACON AAC BLOCK

- Notes: 1. The gap between AAC wall and RC structure shall completely compact with mortar simultaneously on every course of block work.
2. For high grade of RC structure, use the nail gun or drilling with wall plug to fasten the L-Bracket.

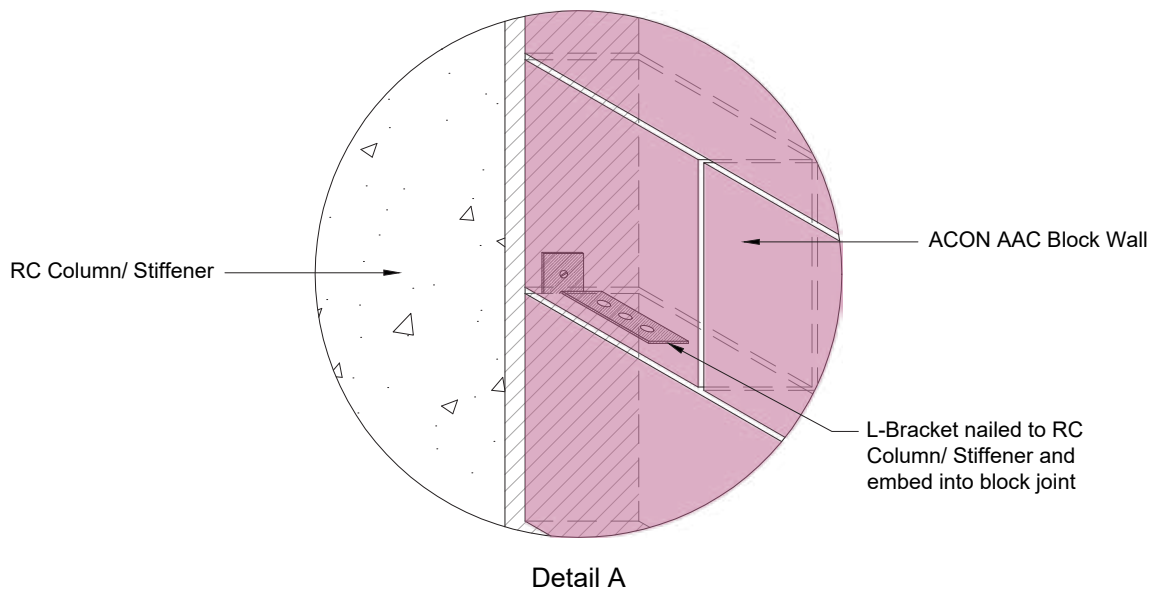
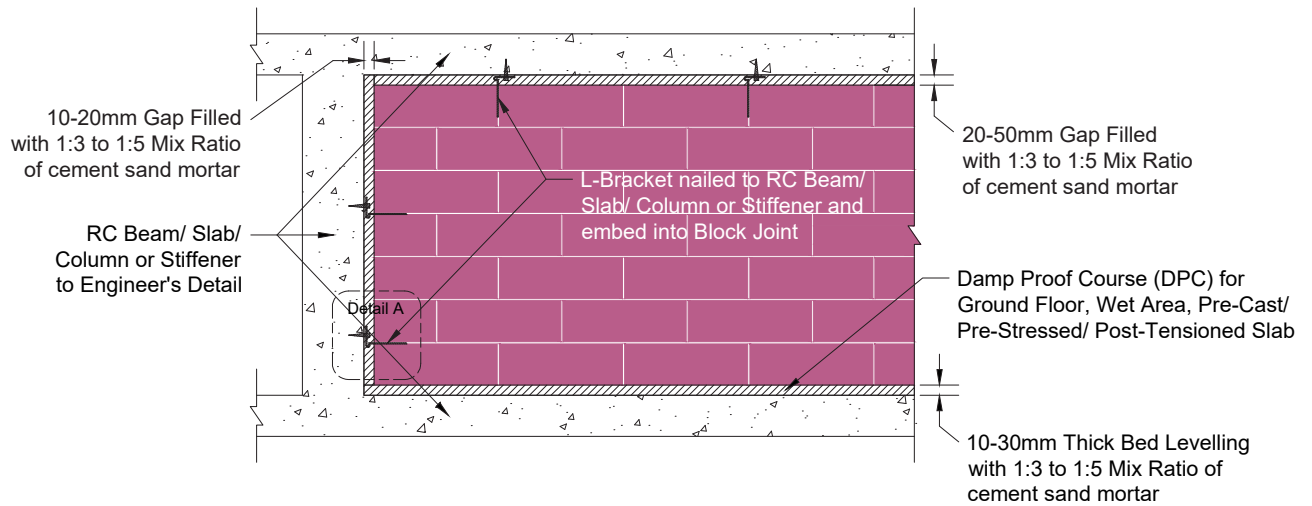

BASIC INSTALLATION FOR ACON AAC BLOCK WALL

- Notes:
1. L-Bracket required at every 600mm vertically, and 1200mm horizontally as per manufacturer's specifications.
 2. For cross wall, L-Bracket are not required.
 3. Assemble block wall in stretcher bond pattern, and avoid cut/ small piece in the middle of block wall erection (Utilize it where to terminate the last course/ block).
 4. Chases formed on the completed wall must comply with UBBL Malaysia requirements.

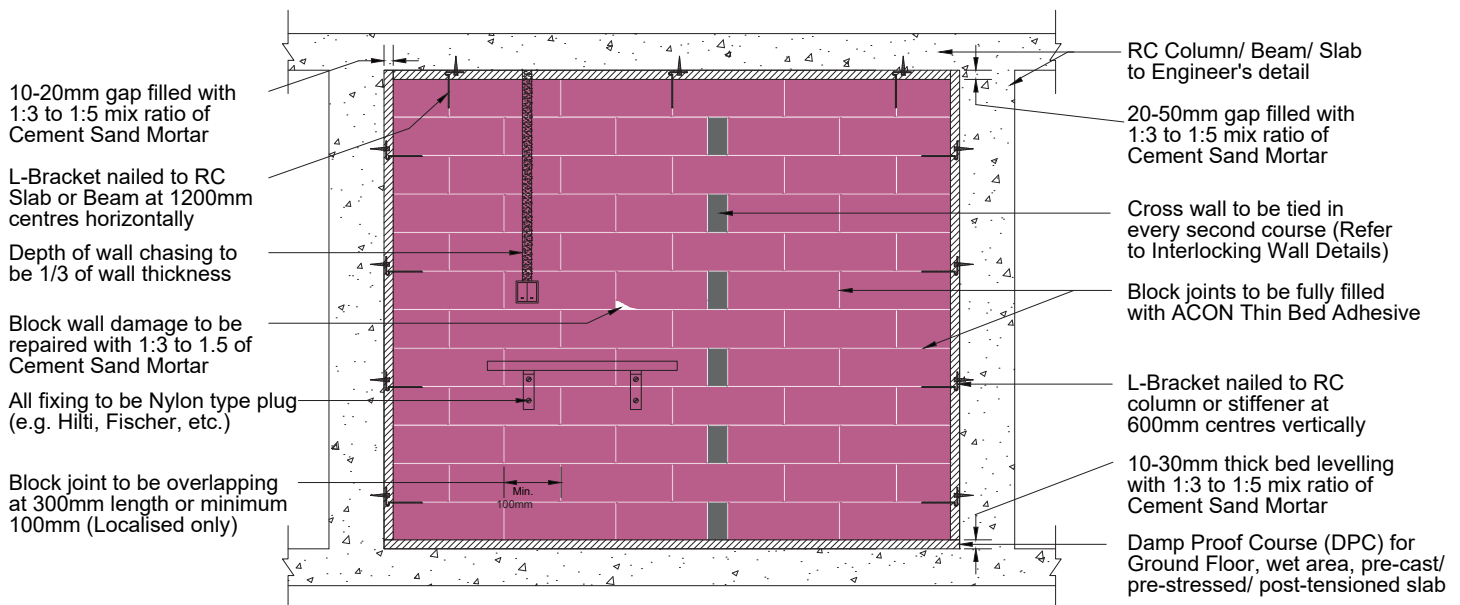

INTERLOCKING BLOCK WALL AT JUNCTION AND CORNER (ISOMETRIC VIEW)

- Notes:
1. For cross wall, L-Bracket are not required.
 2. Block joint to be overlapping at minimum of 100mm length.

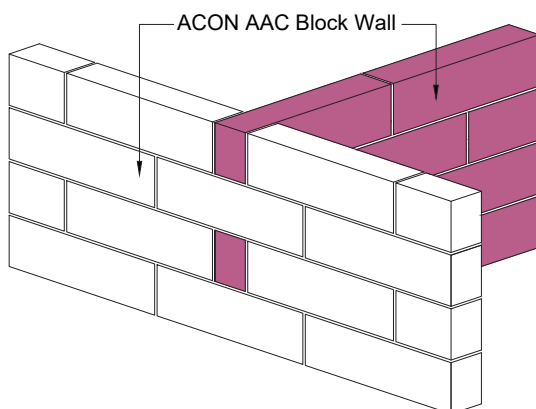

Junction

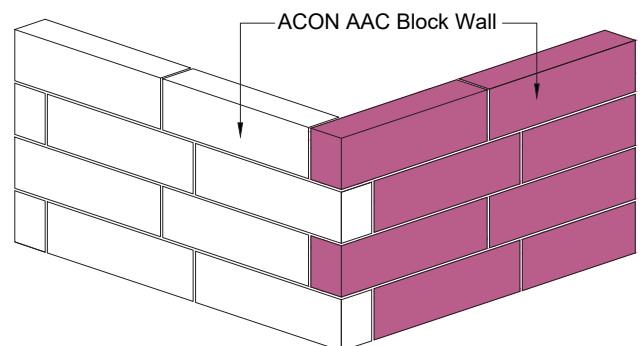

Corner

CASE 1

WINDOW AND DOOR FRAME INSTALLATION

- Notes:
1. Install door and window frame as per manufacturer's instructions.
 2. Door frame shall install before erection of AAC block wall.
 3. Provide self-adhesive fibermesh at every lintel seating where it help prevent the propagation of cracks occur.
 4. For fire door or heavy solid door, it must be contributed with support such as RC stiffener. *(Refer to Stiffener Requirements Section)*
 5. To extend the block under lintel at minimum of 125mm length.

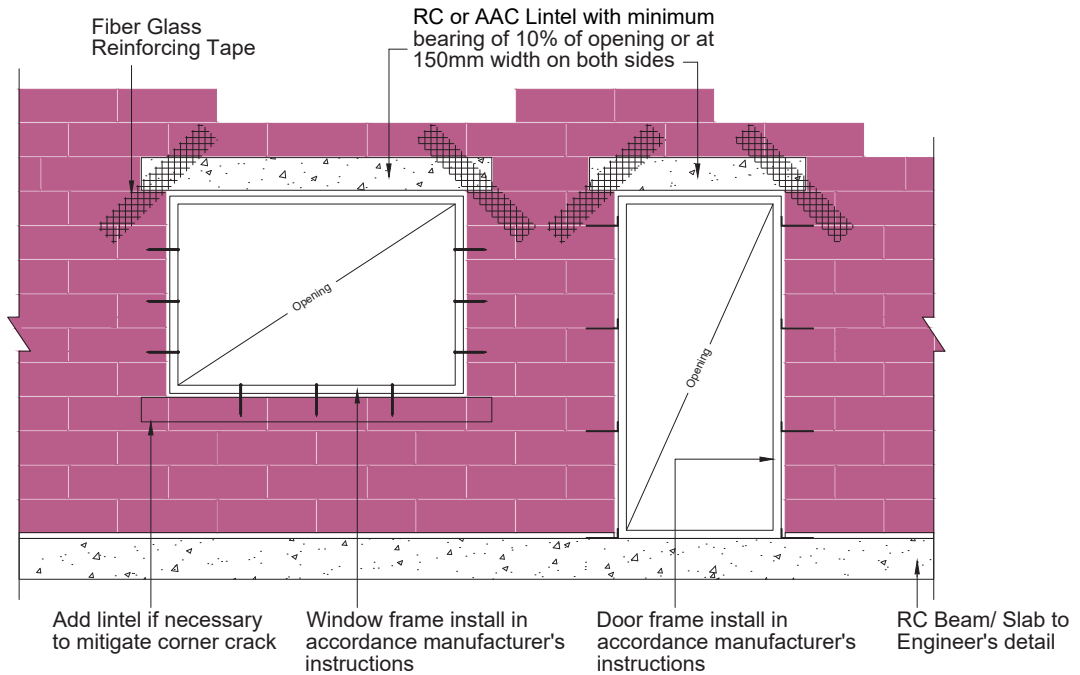

WINDOW AND DOOR FRAME INSTALLATION

- Notes:
1. Install door and window frame as per manufacturer's instructions.
 2. Door frame shall install before erection of AAC block wall.
 3. Provide self-adhesive fibermesh at every lintel seating where it help prevent the propagation of cracks occur.
 4. For fire door or heavy solid door, it must be contributed with support such as RC stiffener and lintel beam. *(Refer to Stiffener Requirements Section)*
 5. To extend the block under lintel at minimum of 125mm length.

CASE 2

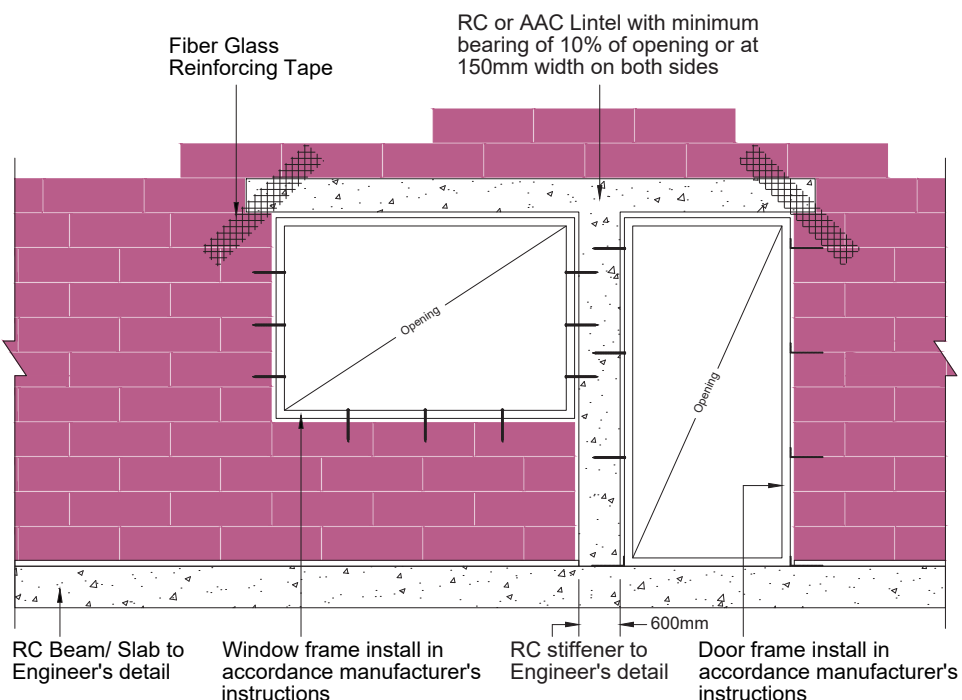

CHASING REQUIREMENTS ON ACON AAC BLOCK WALL (ISOMETRIC VIEW)

- Notes:
1. Chases on ACON block wall should be carried out before the application of skim coat or render.
 2. Fiber Glass Reinforcing Tape is used to reinforce joints and it help prevent the propagation of cracks occur.
For best result, Fibermesh to embed in skim coat layer.
 3. Apply 150mm wide Fibermesh to get extended overlap after cut edge of chase wall. The minimum overlap is 25mm.
 4. Chases formed on party wall shall leave behind at minimum 100mm thick of block.

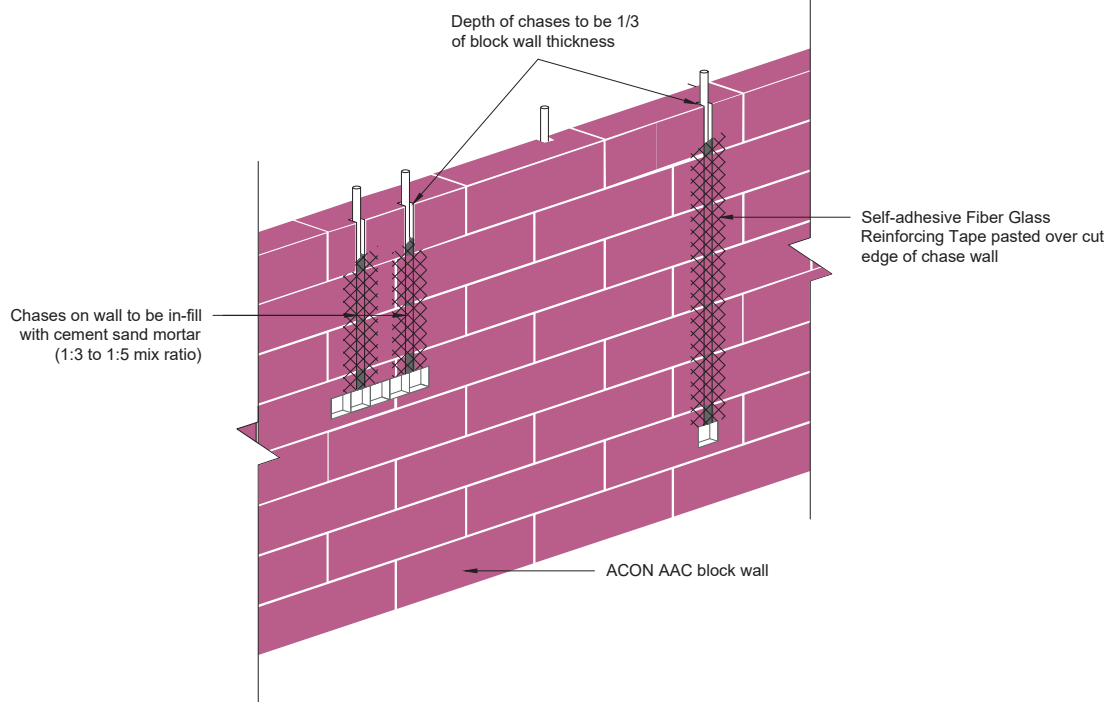

CHASING REQUIREMENTS ON ACON AAC BLOCK WALL (ISOMETRIC VIEW)

- Notes:
1. Chases on ACON block wall should be carried out before the application of skim coat or render.
 2. Fiber Glass Reinforcing Tape is used to reinforce joints and it help prevent the propagation of cracks occur.
For best result, Fibermesh to embed in skim coat layer.
 3. Apply 150mm wide Fibermesh to get extended overlap after cut edge of chase wall.
The minimum overlap is 25mm.
 4. Chases formed on party wall shall leave behind at minimum 100mm thick of block.

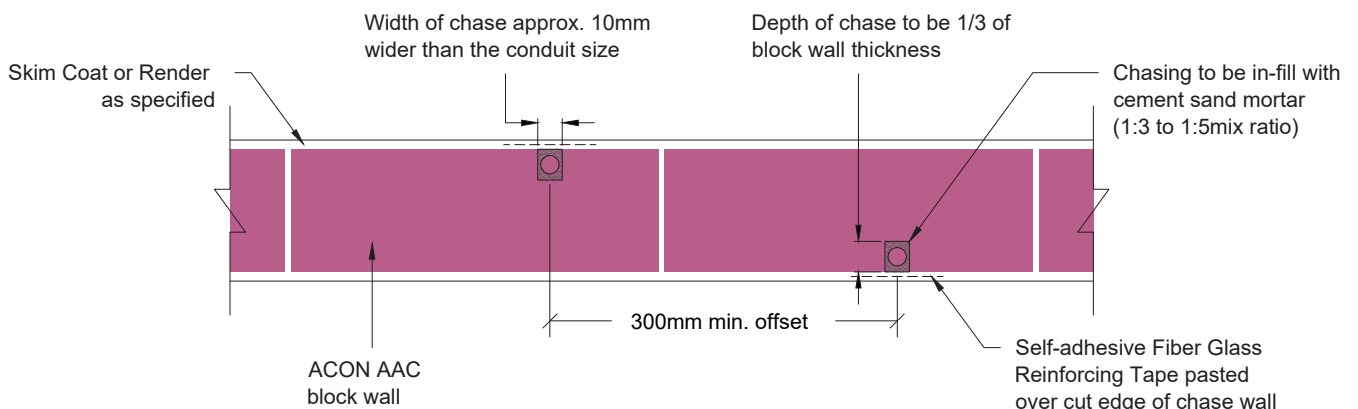

Gabel End Wall & Parapet Wall ACON AAC Block Wall

GABET END WALL

Notes: 1. If necessary, RC stiffener and capping beam may also be built after erection of block wall.

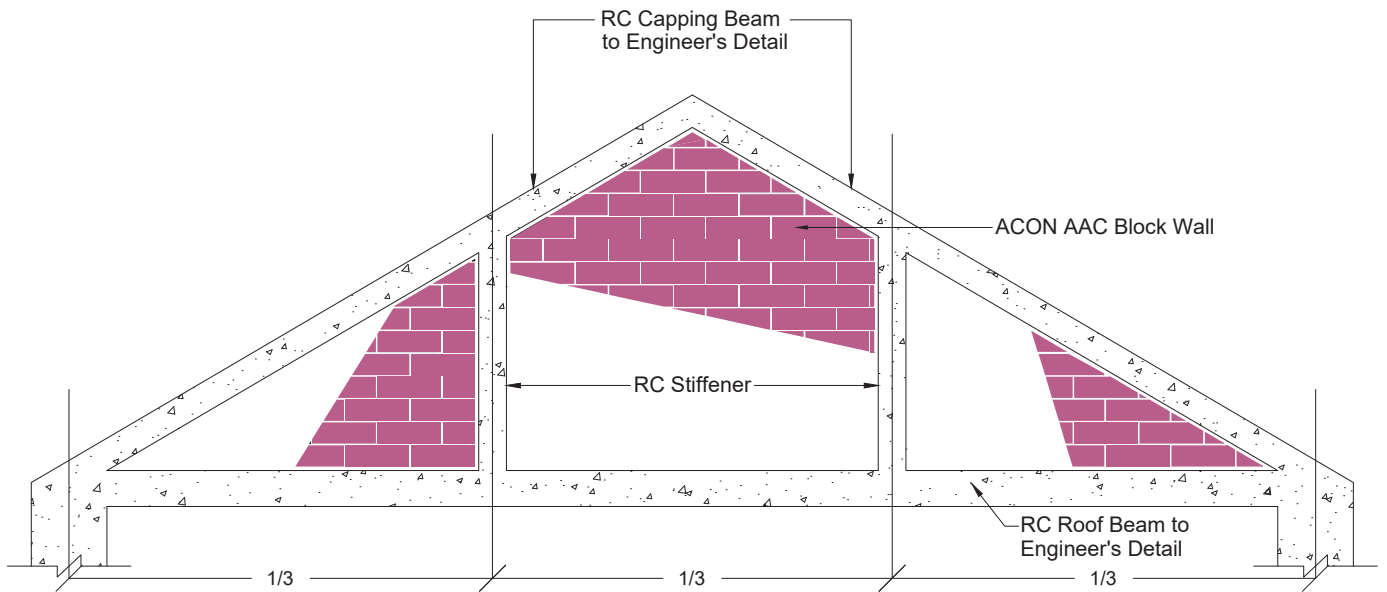

PARAPET WALL

Notes: 1. If necessary, RC stiffener and capping beam may also be built after erection of block wall.

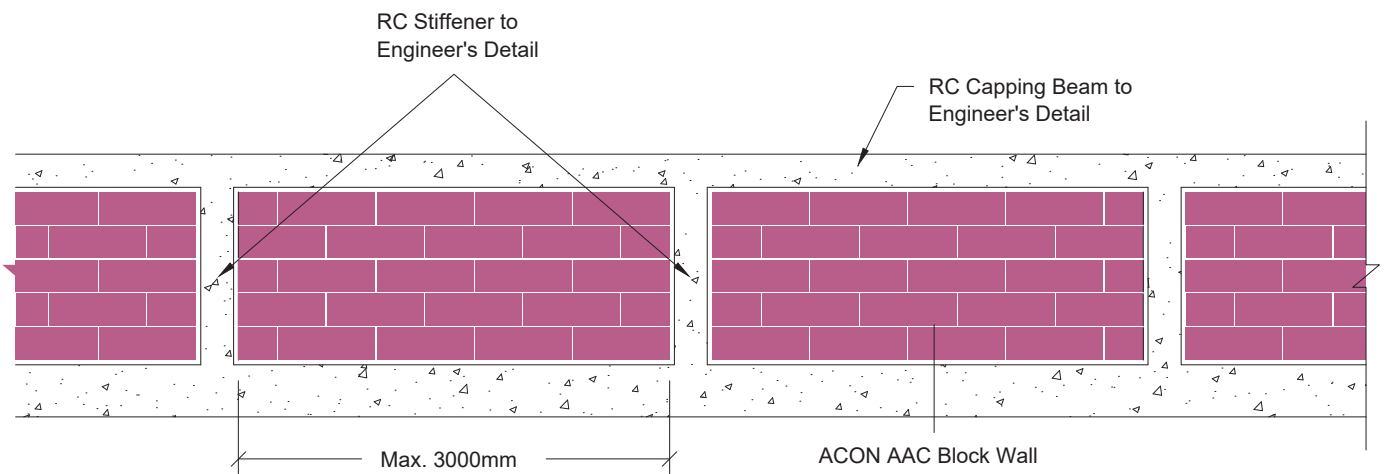

FINISHES COATING FOR INTERNAL WALL

- Notes:
1. To remove any debris, excessive of adhesive, and also the damage wall to be rectified before commence of skim coating on AAC block wall.
 2. Maximum nominal skim coat thickness inclusive of Skim Coat Base and Skim Coat Finish approximately at 5-6mm thk per finish coat.
 3. For the application of site-mix plastering on AAC block wall, kindly consult ACON for further information.

DRY AREA

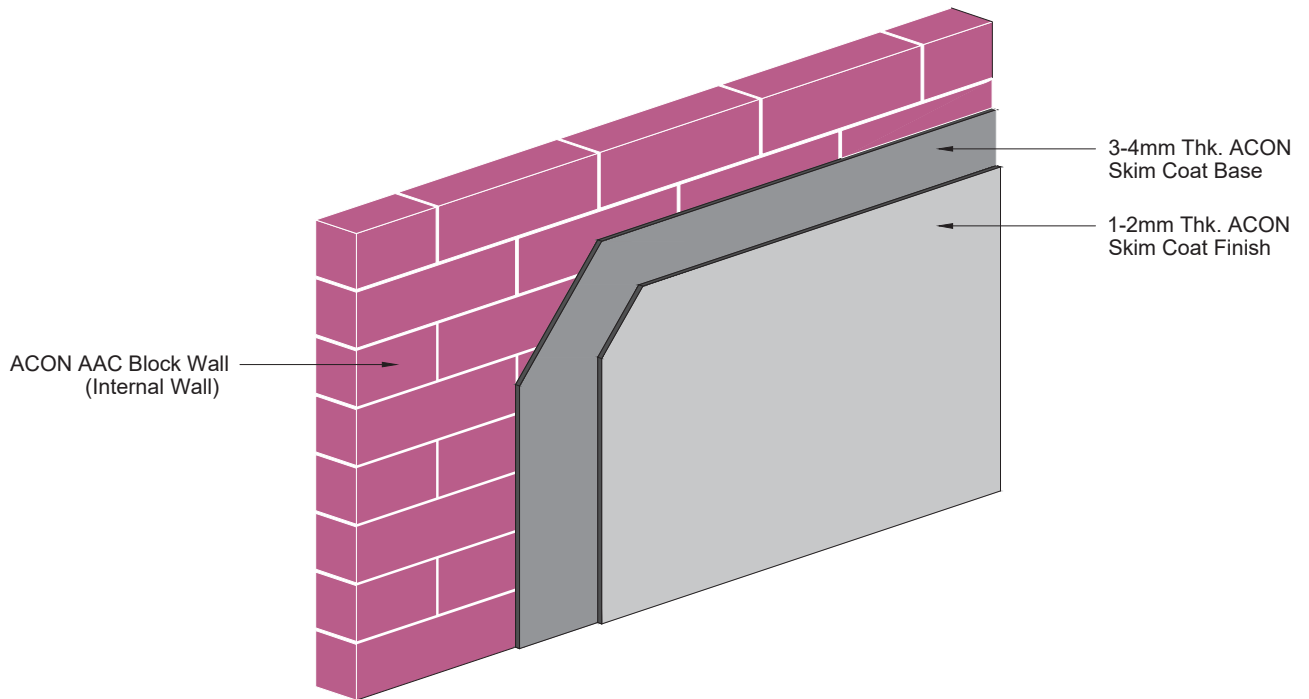

FINISHES COATING FOR EXTERNAL WALL

- Notes:
1. Do not mix ACON AAC Render with fine sand.
 2. To remove any debris, excessive of adhesive, and also the damage wall to be rectified before commencement of rendering on AAC block wall.
 3. Maximum nominal render thickness approximately at 10-12mm thk. per finish coat.
 4. For the application of site-mix plastering on AAC block wall, kindly consult ACON for further information.

OUTDOOR SIDE

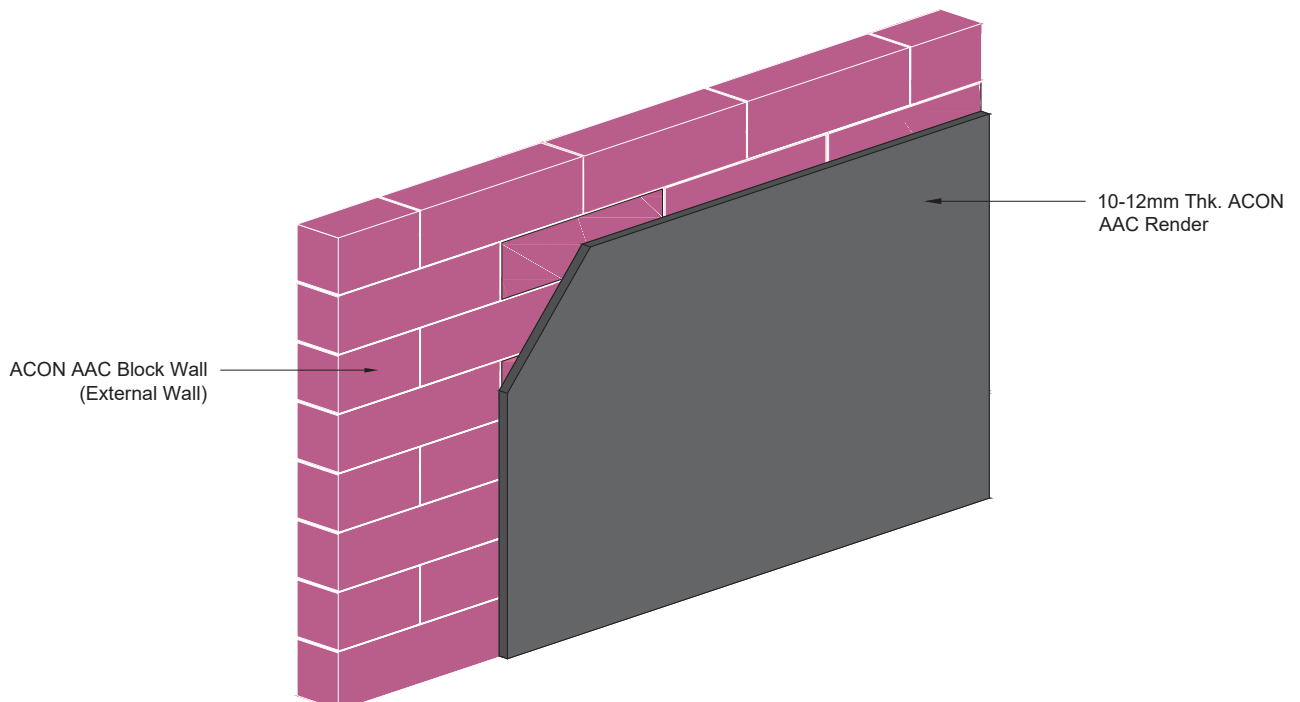

WET AREA

FINISHES COATING FOR INTERNAL WALL

- Notes: 1. The diagrams refer to typical details for wet area in all cases. Thus, please refer to contract documents or construction drawings of specific project.
2. To remove any debris, excessive of adhesive, and also the damage wall to be rectified before commence of rendering on AAC block wall.
 3. Maximum nominal render thickness approximately at 10-12mm thk. per finish coat.
 4. For waterproofing and tile adhesive material, kindly consult the manufacturers for recommendation.
 5. For the application of site-mix plastering on AAC block wall, kindly consult ACON for further information.

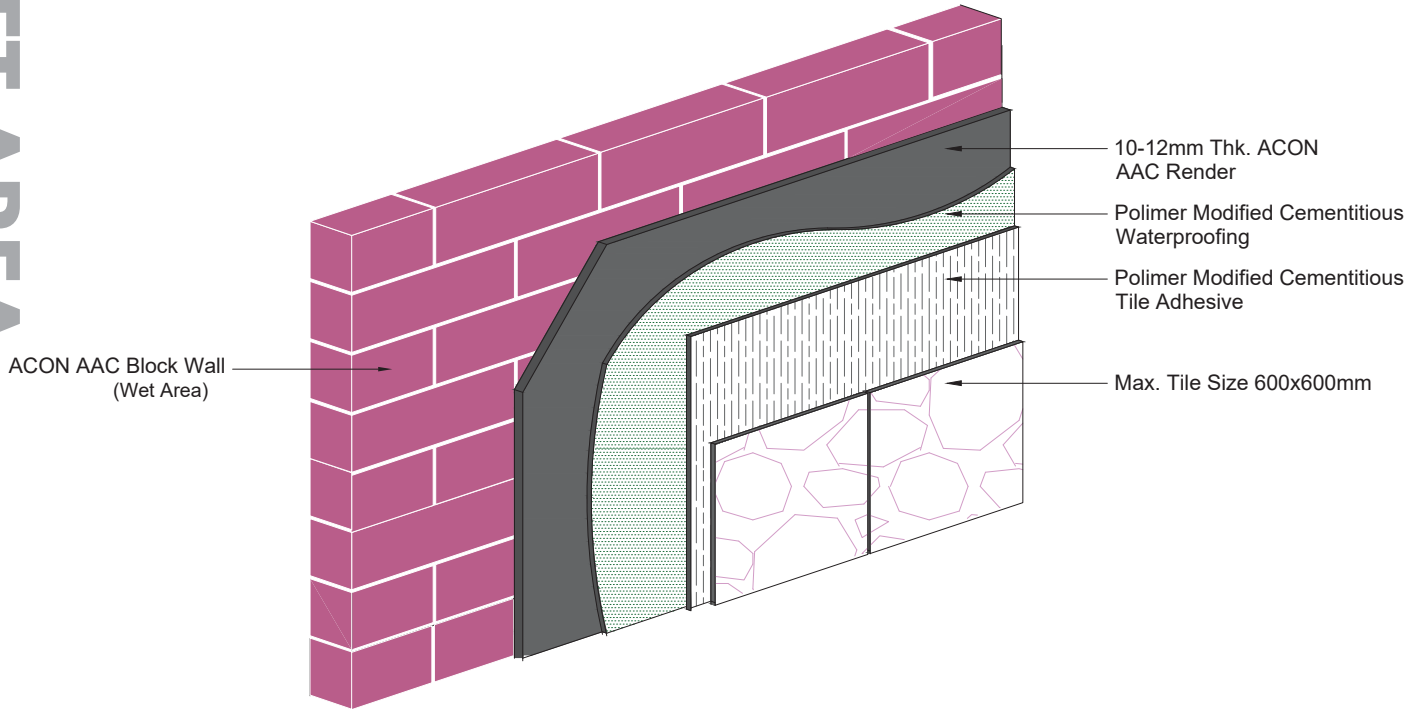

TYPICAL DETAIL FOR WET AREA

- Notes: 1. The diagrams refer to typical details for wet area in all cases. Thus, please refer to contract documents or construction drawings of specific project.
2. To remove any debris, excessive of adhesive, and also the damage wall to be rectified before commence of rendering on AAC block wall.
 3. Maximum nominal render thickness approximately at 10-12mm thk. per finish coat.
 4. For waterproofing and tile adhesive material, kindly consult the manufacturers for recommendation.
 5. For the application of site-mix plastering on AAC block wall, kindly consult ACON for further information.

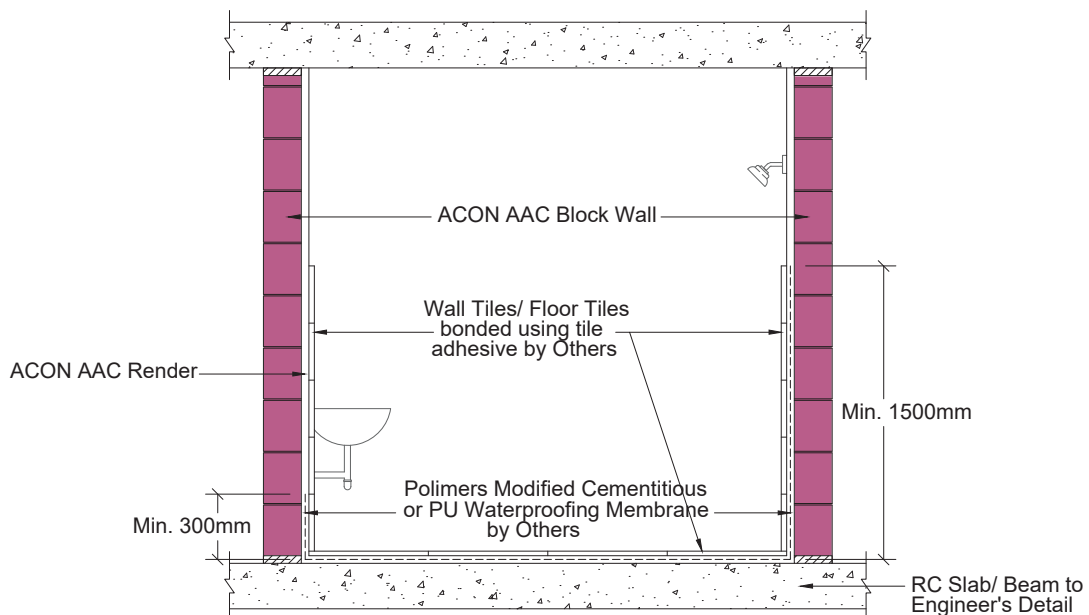

Stiffener Requirements ACON AAC Block Wall

VERTICAL AND HORIZONTAL STIFFENER, NON - FULL HEIGHT WALL

- Notes: 1. If necessary, RC stiffener and capping beam may also be constructed after erection of block wall.
2. Provide horizontal stiffener and vertical stiffener when block wall exceed 4500mm height and 4000mm length.

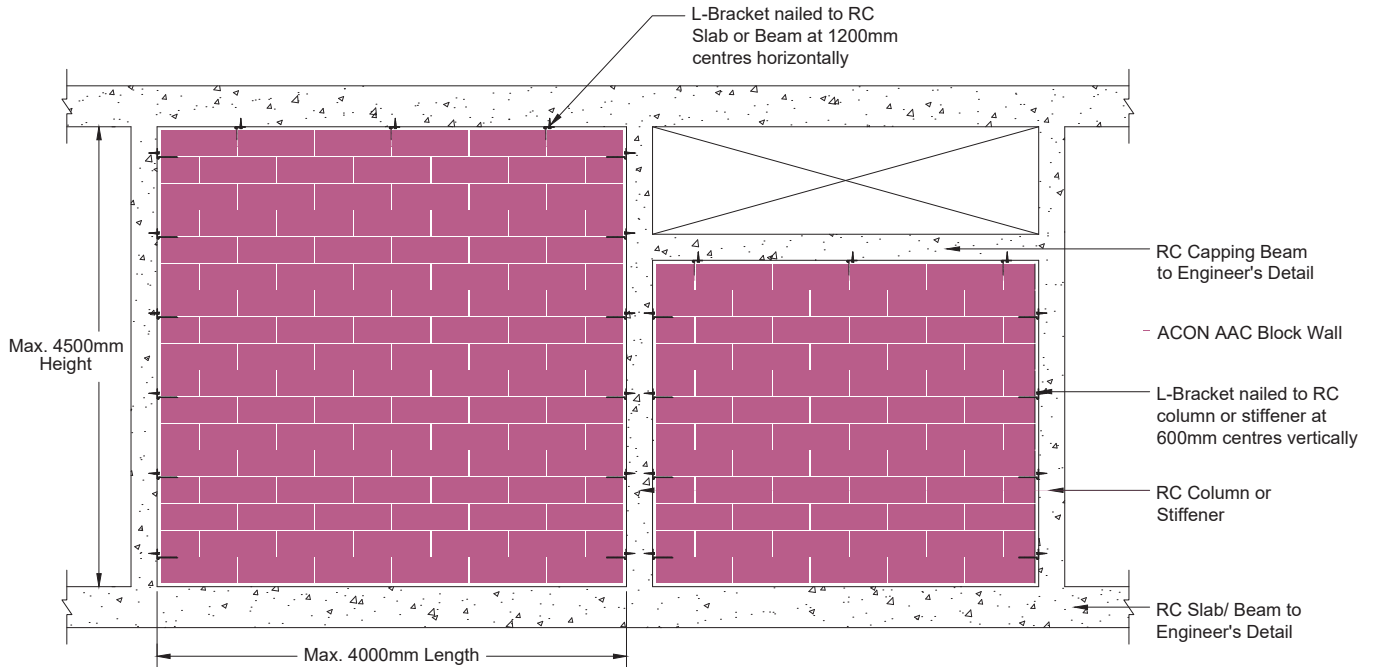

FIRE RATED DOOR, HEAVEY SOLID DOOR & LARGE OR DOUBLE LEAF DOOR

- Notes: 1. If necessary, RC stiffener and capping beam may also be constructed after erection of block wall.

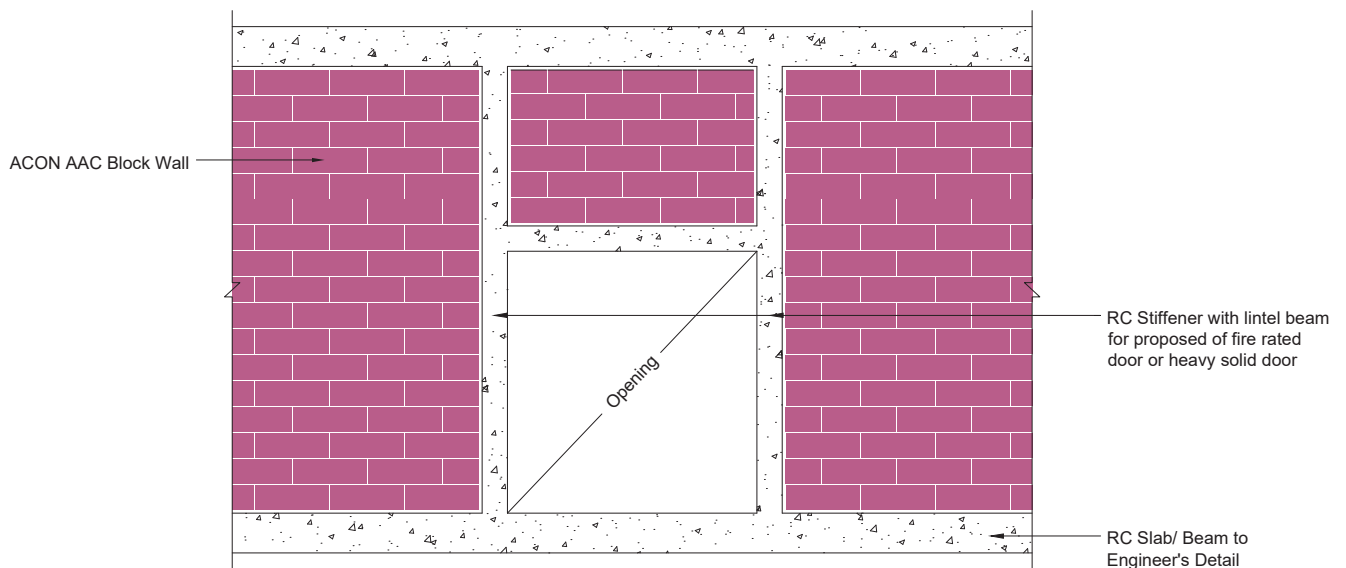

Stiffener Requirements

ACON AAC Block Wall

ACON AAC BLOCK WALL AND OTHER MASONRY WALL JUNCTION

Notes: 1. Dimension of RC stiffener shall be adjusted to match with AAC block wall thickness.
Thus, the details of RC stiffener is subject to qualified Engineer.

ISOMETRIC VIEW

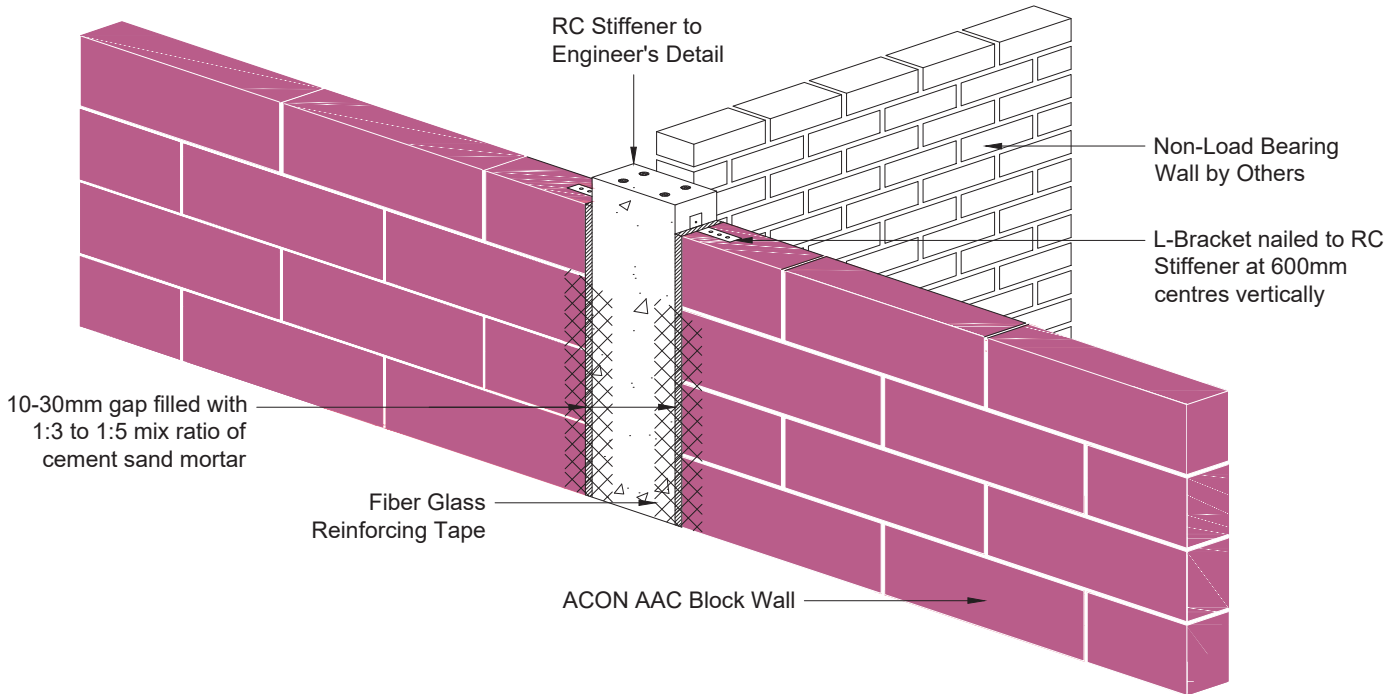

ACON AAC BLOCK WALL AND OTHER MASONRY WALL JUNCTION

Notes: 1. Dimension of RC stiffener shall be adjusted to match with AAC block wall thickness.
Thus, the details of RC stiffener is subject to qualified Engineer.

PLAN VIEW

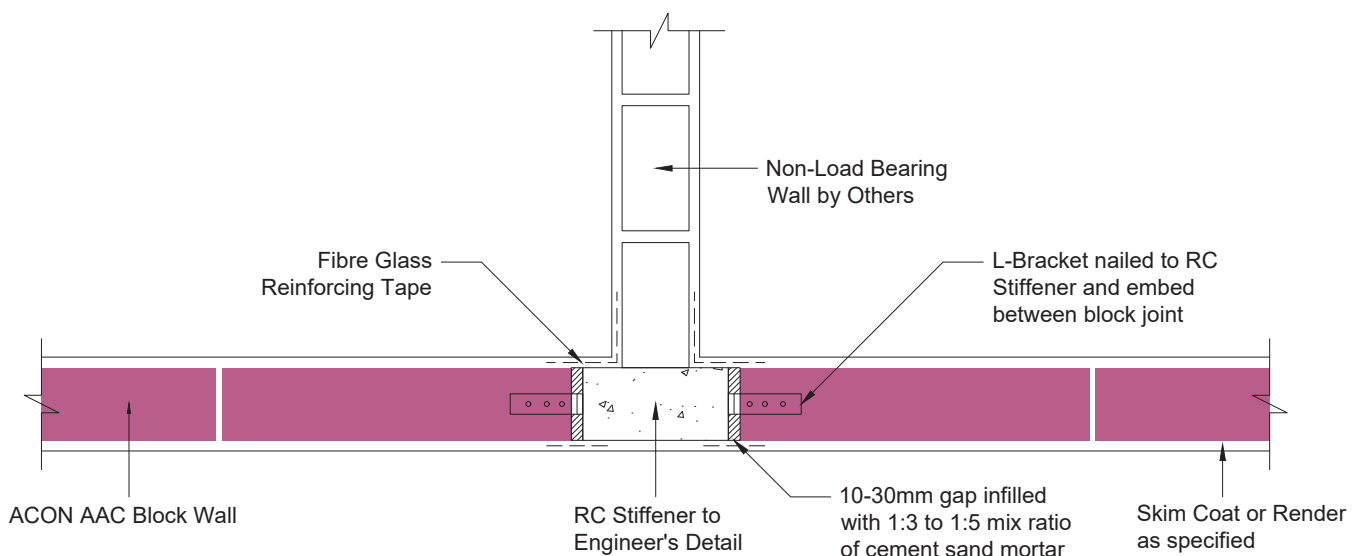

Application Of Fiber Glass Reinforcing Tape

ACON AAC Block Wall

TYPICAL APPLICATION ON FIBERMESH ON ACON AAC BLOCK WALL

- Notes: 1. Use a minimum of 150mm wide Fibermesh to get a sufficient of overlapping over the joints.
2. ACON recommends the Fibermesh to be embedded into the skim coat (base).

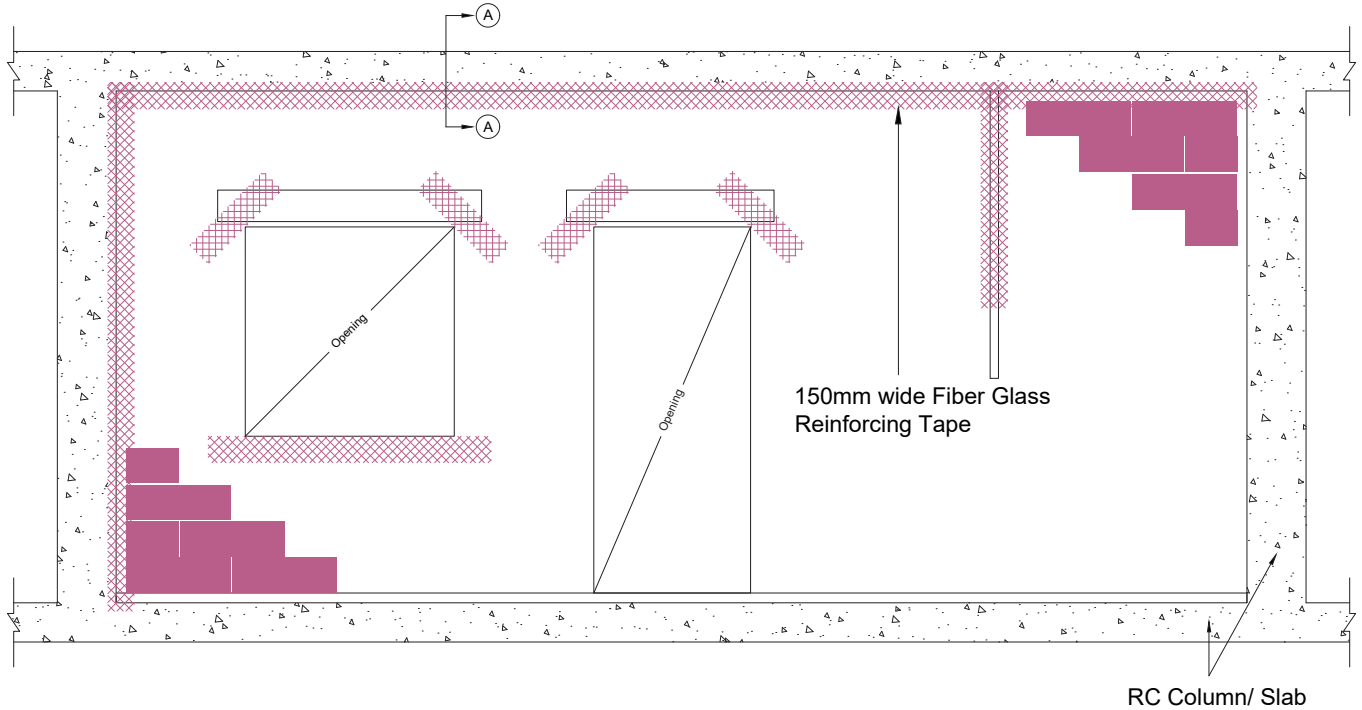

SECTION A-A

- Notes: 1. Use a minimum of 150mm wide Fibermesh to get a sufficient of overlapping over the joints.
2. ACON recommends the Fibermesh to be embedded into the skim coat (base).

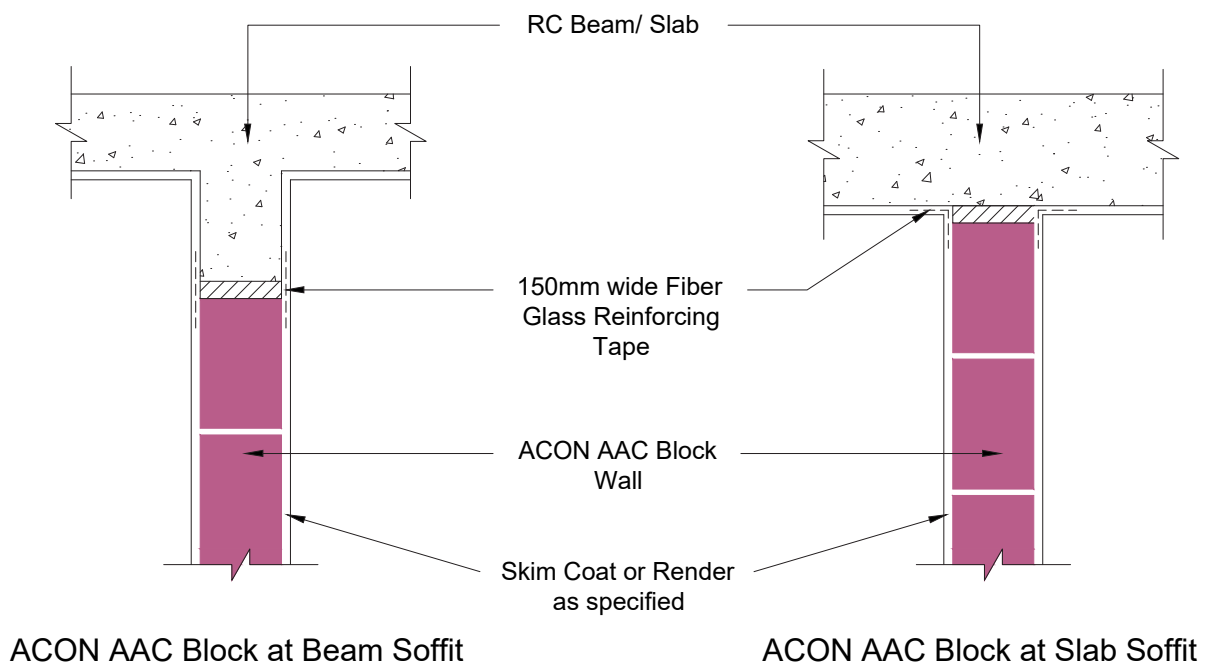

Steel Structure Support ACON AAC Block Wall

STEEL STRUCTURE SUPPORT

Notes: 1. L-Bracket required at every 600mm vertically, and 1200mm horizontally as per manufacturer's specifications.

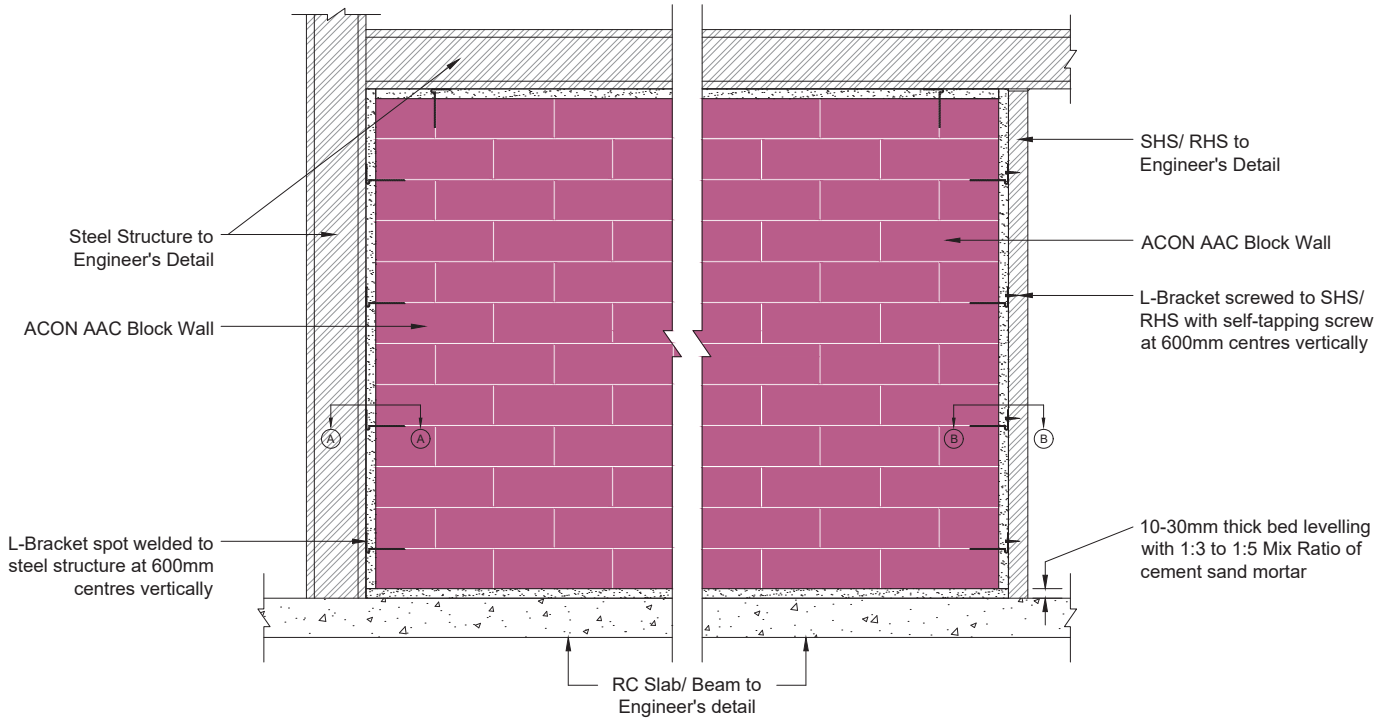

SECTION A-A AND SECTION B-B

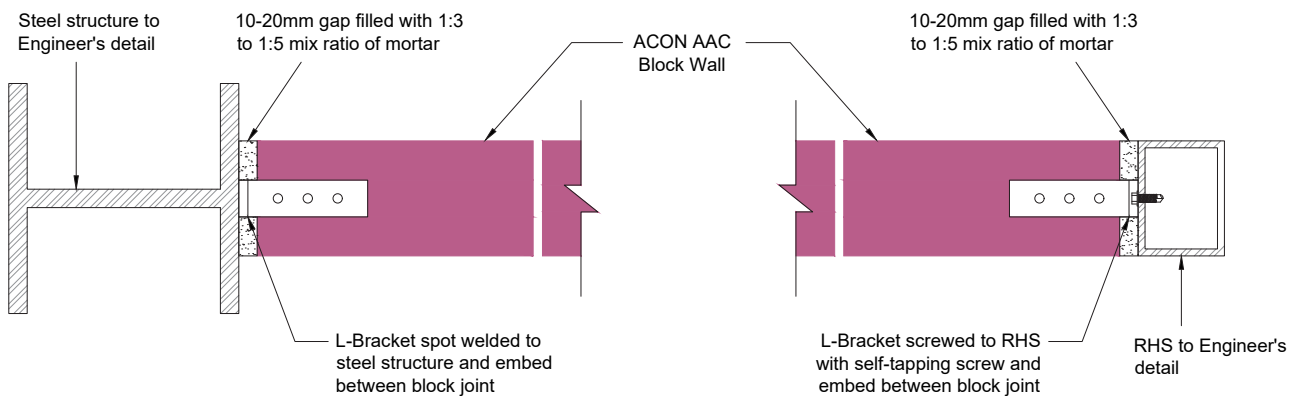

Section A-A: ACON AAC Block and Steel Structure

Section B-B: ACON AAC Block and Steel Structure (RHS)

ALAM-CON SDN BHD

Ipoh Office (HQ Factory)

PT9125, Taman Perindustrian Tungzen,
Kampung Kepayang,
31300 Ipoh, Perak.
Tel: 017-958 5933

Penang (Warehouse)

Lot 4209, Kawasan Perindustrian Padang Meha,
09410 Kulim, Kedah.
Tel: 017-745 0100

KL Office (Marketing)

Block A-1-07,
Jalan Pandan Indah 8,
Taman Pandan Mas,
55100, Ampang, Kuala Lumpur
Tel: 017-764 5933

Melaka Office (Factory)

No 9521-A, Jalan PBR25,
Kawasan Perindustrian Bukit Rambai,
75250, Melaka

Kota Kinabalu (Warehouse)

No. 8&9, Lorong Burung Keleto,
Nountun Bahru, Mile 5,
Jalan Tuaran, 88450 Inanam,
Kota Kinabalu, Sabah
Tel: 012-957 3359



Alam-Con Sdn Bhd



alamcon6464@gmail.com



017-958 5933



www.alamcon.com.my