

1. Mount the cylinder at desired place with bolts and locating pin after choosing a mounting surface. Connect the cylinder and control valve with joint and rubber hose. To adjust the opening and closure speed, our pneumatic power welding clamp is equipped with return stroke air buffering. Buffering cannot function well if the clamping arm is over-weighted so that clamping arm' weight must be within the allowable limit;
2. Using clamping arm beyond the listed in this catalog is forbidden.
3. Workpiece mounting method:
 - 3.1) When only clamping torque is used for clamping:

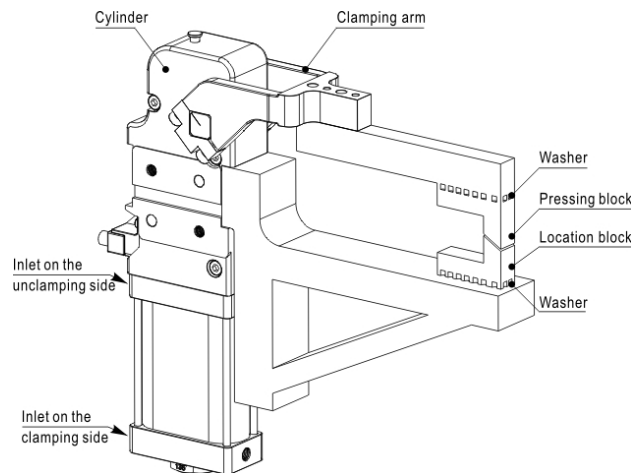

Please follow the steps to mount the workpiece onto the clamping arm:

- A) Clamping the arm: supply compressed air through the inlet on the clamping side to keep the arm and pressing block at the closure position simultaneously. Make sure the arm is locked up.
- B) Adjusting the clamping gap: adjust the spacer under the mentioned state to make the pressing block in line with the workpiece's thickness. (At this moment no clamping torque is produced theoretically.)
- C) Applying clamping torque: Insert the spacer furthermore under the mentioned state until the gap is smaller than the workpiece's thickness and desired clamping torque is produced. (Make sure the mechanism passes the dead position to produce self-locking i.e. the retaining pin is pushed out.)

- 3.2) When hard braking is used for clamping:

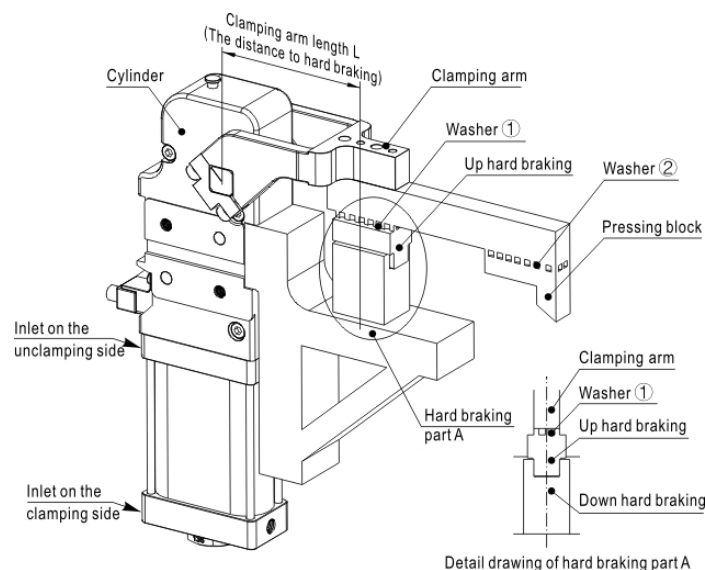

Please follow the steps to mount the workpiece onto the clamping arm:

A) clamping the arm: supply compressed air through the inlet on the closure side to keep the arm and the braking block at the clamping position simultaneously. Make sure the arm is locked up;

B) Adjusting the clamping gap: Adjust washer ① under the mentioned state until the gap between the upside braking block and downside one. (At this moment no clamping torque is produced theoretically.)

C) Applying clamping torque: insert the washer ① furthermore under the mentioned state to produce desired clamping torque. (Make sure the mechanism passes the dead position to produce self-locking i.e. the retaining pin is pushed out.)

D) Adjust washer ② under the state mentioned in C to make the pressing block in contact with the workpiece.

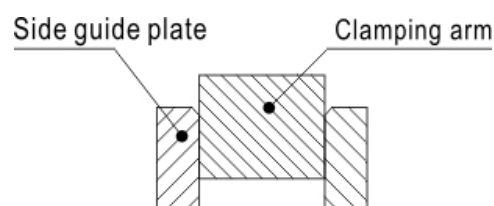

3.3) When side guide plate is mounted:

Side guide plate is mounted on the clamping arm to prevent transverse movement and make sure that no transverse load is applied and that the arm would not be stuck.

4. Angle adjusting method:

Standard adjusting angle range of the pneumatic clamp is 15°~135°. Opening angle can be changed via changing cylinder's stroke distance or the sensor's position;

4.1) Step 1 of adjusting angle--change of sensor's position:

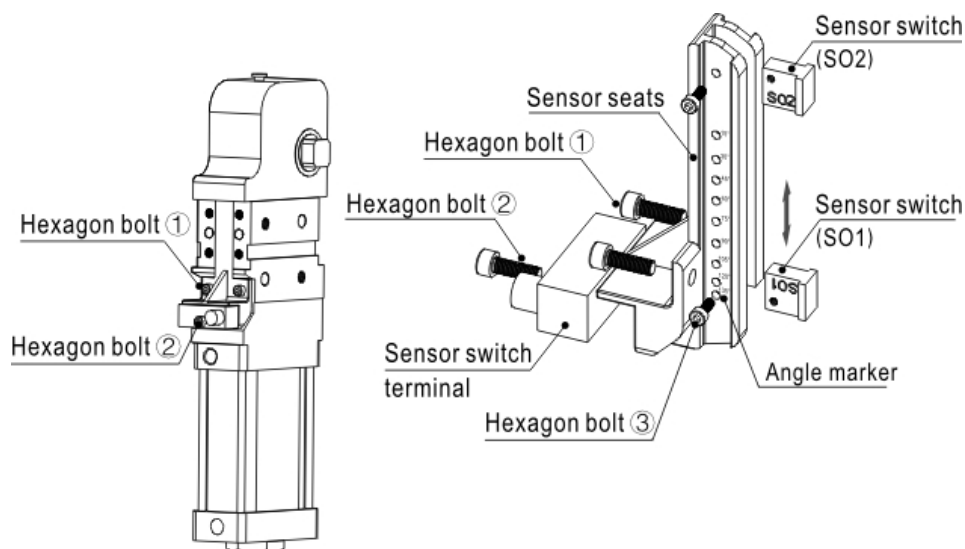

A) Unscrew hexagon bolt ① with inner hexagon wrench to take out the sensor seats;

B) Unscrew hexagon bolt ③ with inner hexagon wrench to take out SO1 and align it to your desired angle indication position and re-screw up hexagon bolt ③. (Note: when mounting sensor SO1, the number "SO1" should point downward except 15°.)

C) After the sensor's position is adjusted, replace the sensor seats by screwing up hexagon bolt ① with inner hexagon wrench (lock-up torque by related contents).

Note: 1) sensor SO2 controls the cylinder's end stroke position and its mounting position is well

set when leaving factory and is not changeable.

2) the sensor wiring box is provided with two outgoing orientations: forward and downward. Unscrew hexagon bolt ② and then you can change the wiring box orientation. After that, screw up hexagon bolt ②.

3) When remounting the sensor fix to its original position, the gap between the sensor and Y-knuckle should be less than 1.5mm. Otherwise, the sensor may not function well.

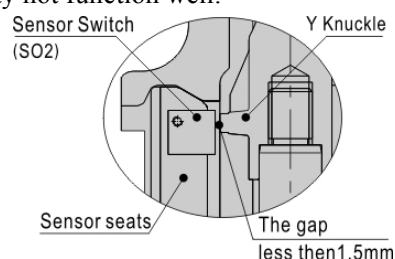

4.2) Step 2 of adjusting angle--change of the cylinder's stroke distance:

The relation between the opening angle of clamping arm and cylinder's stroke distance is listed as follows:

Opening angle\ Type	JCK40	JCK50	JCK63	JCK80
15°	20.2	21.6	23.1	36.1
30°	28.1	30.2	33.4	50.5
45°	34.8	37.5	41.6	62.7
60°	41.4	44.6	49.7	74.5
75°	48.0	51.8	57.5	86.3
90°	54.8	59.2	65.7	98.1
105°	61.5	66.4	73.8	109.6
120°	67.4	72.7	81.0	119.5
135°	71.6	77.3	86.2	126.4

During actual operation, the cylinder's stroke can be changed by changing the adjusting screw at the bottom to control the clamping arm's opening angle. Detailed description is as follows:

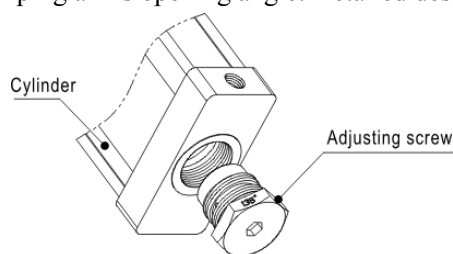

- Unscrew original adjusting screw with inner hexagon wrench
- Choose suitable adjusting screw according to actual need (the bottom is marked with corresponding opening angle).
- Screw up new adjusting screw into the cylinder's end cap.

5. Mounting clamping arm:

The clamping arm is already mounted when leaving factory which can be remounted by yourself horizontally or vertically according to your actual need.

5.1) Mounting clamping arm horizontally:

Unscrew 4 hexagon bolts on both sides of the clamping arm to remove V-shaped block and then the clamping arm for substituting your desired one.

When mounting, please note the direction of the indicating line on the pivot.

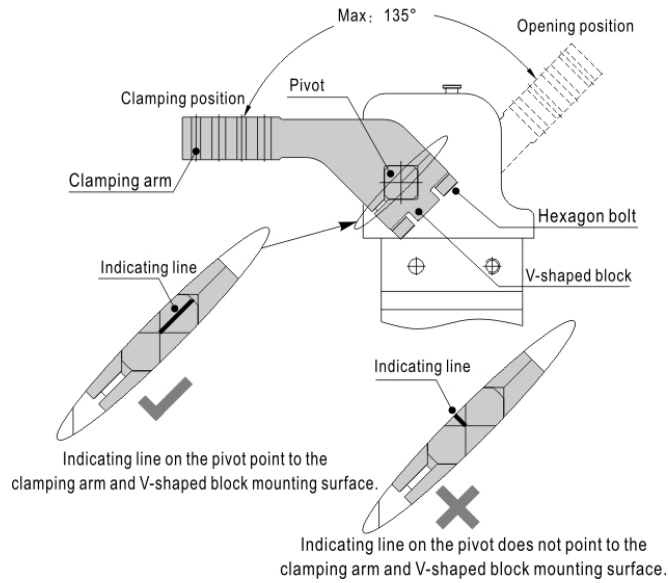

5.2) Mounting clamping arm vertically:

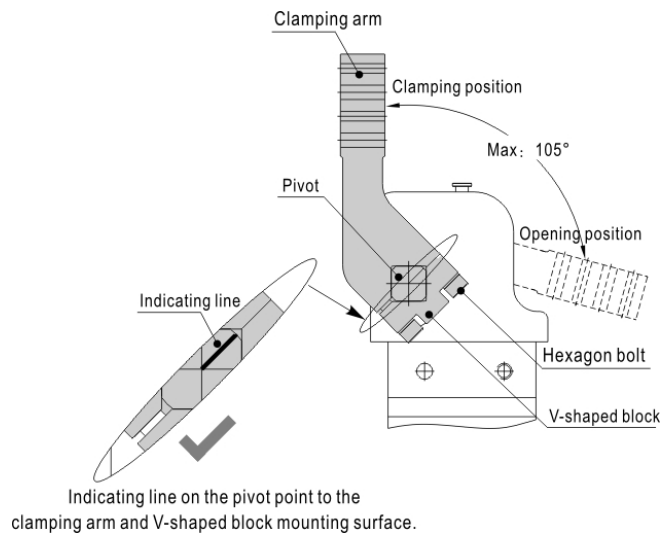

5.3) V-shaped block mounting:

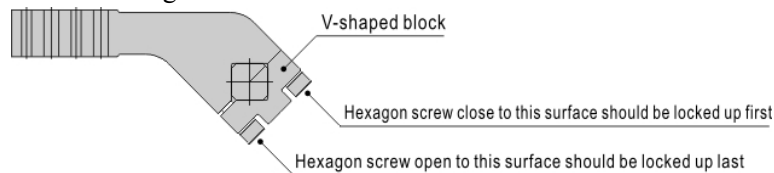

5.4) Holding torque of clamping arm (recommended):

When holding clamping arm, please choose recommended value in the following list:

Bore size	Bolt type	Holding torque (N.m)
40	M6 × 1.0	13.8
50	M6 × 1.0	13.8
63	M8 × 1.25	33.0
80	M10 × 1.5	66.0

6. Self-lock function:

At the end of stroke, the crank-slider mechanism passes the dead point and gets self-locked up. The retaining pin gets pushed up at this moment. Even when compressed air is off, the cylinder can remain at closure state for safety. To open self-locking of the crank-slider mechanism, push

down the retaining pin when compressed air is off.

Warning:

Pushing down the retaining pin may cause clamping arm to spring off at closure state.

So when using the pin, please get yourself away from the clamping arm's operation range.

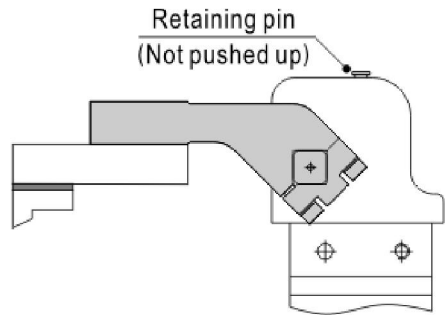

Retaining pin not pushed up,
crank-slider mechanism not self-locked

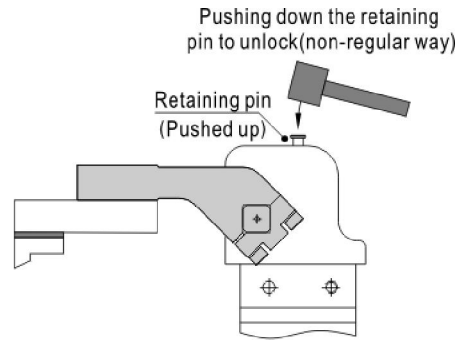

Retaining pin pushed up,
crank-slider mechanism self-locked