

| | | | | | |
|-----|---------------|-------------------|--------|--------------|-------|
| 12 | Scale Plate | Aluminium | 指示板 | A1050 | 1 |
| 11 | Scale Plate | Aluminium | 指示板 | A1050 | 1 |
| 10 | Spindle | Stainless Steel | スピンドル | SUS304 | 1 |
| 9 | Flap Spring | Stainless Steel | フラップばね | SUS304 | 1 |
| 8 | Flap | Stainless Steel | フラップ | SUS304 | 1 |
| 7 | Spring Washer | Carbon Steel | ばね座金 | SWRH | 4 |
| 6 | Nut | Carbon Steel | 六角ナット | S25C or S45C | 4 |
| 5 | Bolt | Carbon Steel | 六角ボルト | SCM435 | 4 |
| 4 | Gasket | Non-Asbestos | ガスケット | Non-Asbestos | 2 |
| 3 | Glass | Tempered Glasses | ガラス | 強化ガラス | 2 |
| 2 | Cover | Ductile Cast Iron | ふた | FCD450 | 2 |
| 1 | Body | Ductile Cast Iron | 本体 | FCD450 | 1 |
| No. | Name of Parts | Material | 部品名 | 材質 | Q. TY |

| (mm) | | | | | |
|------|--------|-----|-------|----|-------------|
| Size | d | L | A | W | Weight (kg) |
| 15A | Rc 1/2 | 80 | 79.0 | 35 | 0.7 |
| 20A | Rc 3/4 | 90 | 79.0 | 35 | 0.8 |
| 25A | Rc 1 | 115 | 100.5 | 44 | 1.4 |

| Specification | |
|---------------|-----|
| Fluid | |
| Press. | MPa |
| Temp. | ℃ |

TYPE SF-1S SIGHT GLASS
サイトグラス

| | |
|-------------|---------------|
| Approval | H. Iwamoto |
| Check | M. Yoshida |
| Drawing | H. Okumura |
| Drawing No. | Y-828-6501-5A |
| Date | 11 SEP.2012 |

Joshitake
INC.

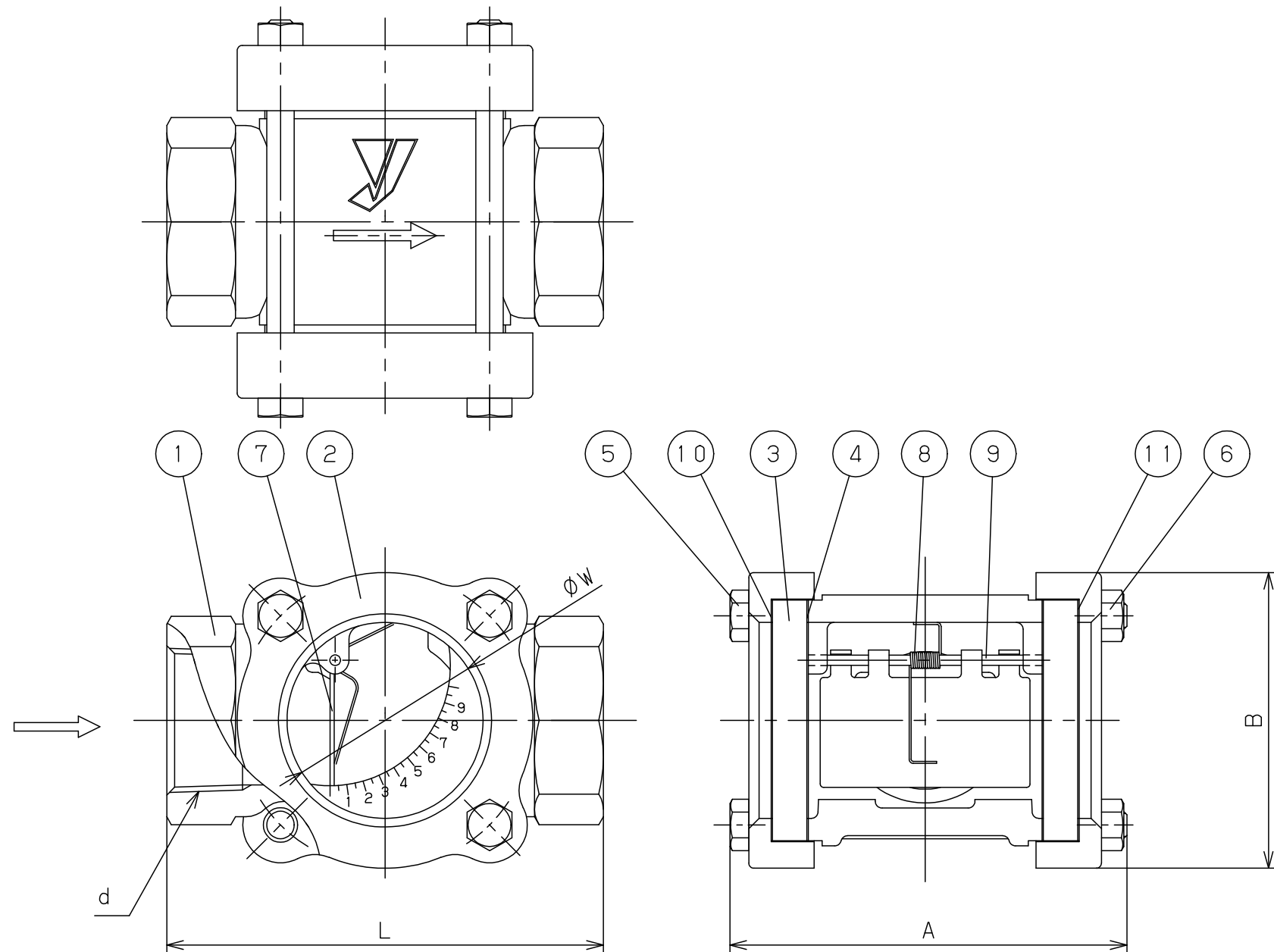

| | | | | | |
|-----|---------------|-------------------|--------|--------------|-------|
| 11 | Scale Plate | Aluminium | 指示板 | A1050 | 1 |
| 10 | Scale Plate | Aluminium | 指示板 | A1050 | 1 |
| 9 | Spindle | Stainless Steel | スピンドル | SUS304 | 1 |
| 8 | Flap Spring | Stainless Steel | フラップばね | SUS304 | 1 |
| 7 | Flap | Stainless Steel | フラップ | SUS304 | 1 |
| 6 | Nut | Carbon Steel | 六角ナット | S45C | 4 |
| 5 | Bolt | Carbon Steel | 六角ボルト | SCM435 | 4 |
| 4 | Gasket | Non-Asbestos | ガスケット | Non-Asbestos | 2 |
| 3 | Glass | Tempered Glasses | ガラス | 強化ガラス | 2 |
| 2 | Cover | Ductile Cast Iron | ふた | FCD450 | 2 |
| 1 | Body | Ductile Cast Iron | 本体 | FCD450 | 1 |
| No. | Name of Parts | Material | 部品名 | 材質 | Q. TY |

| Size | d | L | A | B | W | Weight (kg) |
|------|----------|-----|-------|-----|----|-------------|
| 32A | Rc 1 1/4 | 127 | 120.5 | 86 | 57 | 2.5 |
| 40A | Rc 1 1/2 | 140 | 120.5 | 86 | 57 | 2.8 |
| 50A | Rc 2 | 162 | 147 | 114 | 73 | 5.4 |

| Specification | |
|---------------|-----|
| Fluid | |
| Press. | MPa |
| Temp. | ℃ |

TYPE SF-1S SIGHT GLASS
フラップ式サイトグラス

| | |
|-------------|---------------|
| Approval | H. Iwamoto |
| Check | M. Yoshida |
| Drawing | H. Okumura |
| Drawing No. | Y-828-6501-3A |
| Date | 7 SEP.2012 |