

7	Spring Washer	Carbon Steel	ばね座金	SWRH	4
6	Nut	Carbon Steel	六角ナット	S25C or S45C	4
5	Bolt	Carbon Steel	六角ボルト	SCM435	4
4	Gasket	Non-Asbestos	ガスケット	Non-Asbestos	4
3	Glass	Tempered Glasses	ガラス	強化ガラス	2
2	Cover	Ductile Cast Iron	ふた	FCD450	2
1	Body	Ductile Cast Iron	本体	FCD450	1
No.	Name of Parts	Material	部品名	材質	Q.TY

(mm)

Size	L	A	B	W	Flange JIS 10KFF					Weight (kg)
					d	D	C	T	n-h	
15A	130	79	55	35	15	95	70	12	4-15	2.2
20A	130	79	55	35	20	100	75	14	4-15	2.6
25A	150	99.5	70	44	25	125	90	14	4-19	4.1

Specification	
Fluid	
Press.	MPa
Temp.	°C

**TYPE SL-1F SIGHT GLASS**  
**透視式サイトグラス**

Approval	M. Kume
Check	M. Kume
Drawing	Y. Aoyama
Drawing No.	Y-1063-6505
Date	1 JUL.2010



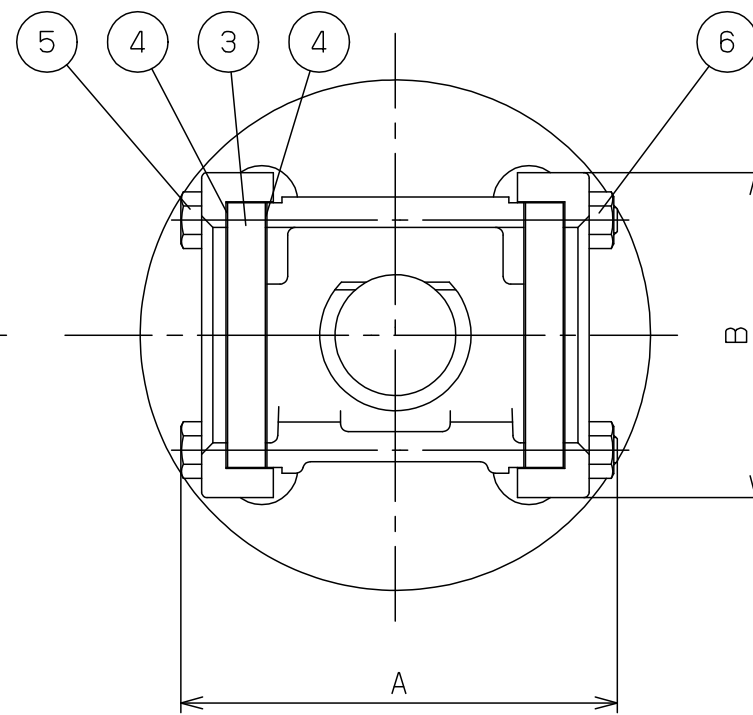
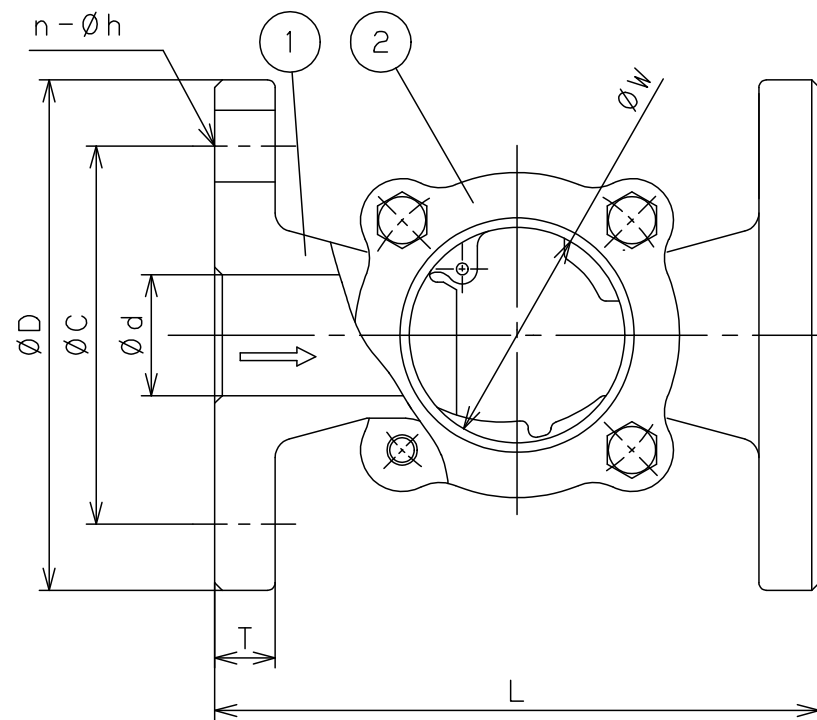
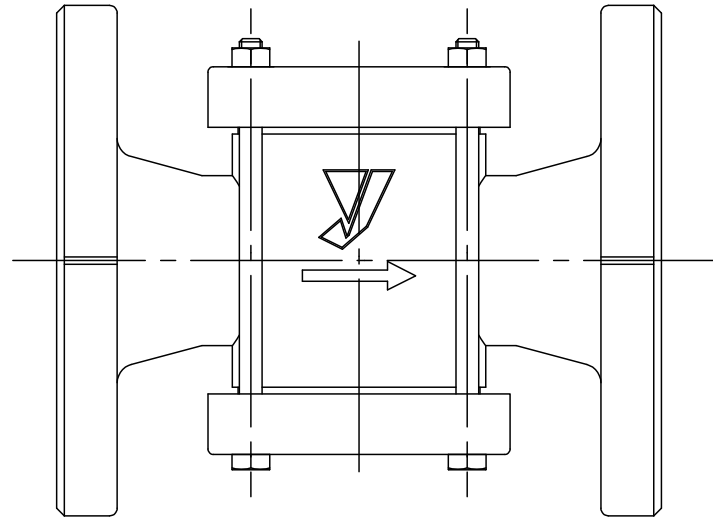

6	Nut	Carbon Steel	六角ナット	S45C	4
5	Bolt	Carbon Steel	六角ボルト	SCM435	4
4	Gasket	Non-Asbestos	ガスケット	Non-Asbestos	4
3	Glass	Tempered Glasses	ガラス	強化ガラス	2
2	Cover	Ductile Cast Iron	ふた	FCD450	2
1	Body	Ductile Cast Iron	本体	FCD450	1
No.	Name of Parts	Material	部品名	材質	Q. TY

Size	L	A	B	W	Flange JIS 10KFF					Weight (kg)
					d	D	C	T	n-h	
32A	160	120.5	86	57	32	135	100	16	4-19	5.7
40A	170	120.5	86	57	40	140	105	16	4-19	6.0
50A	200	147	114	73	50	155	120	16	4-19	9.3

Specification	
Fluid	
Press.	MPa
Temp.	℃

TYPE SL-1F SIGHT GLASS  
透視式サイトグラス

Approval	H. Iwamoto
Check	M. Yoshida
Drawing	H. Okumura
Drawing No.	Y-1063-6505-1A
Date	7 SEP. 2012

