

Full bore, Split body, Side entry design

Features

- Antistatic device
- Blowout-proof stem
- Double "D" stem head
- High performance **HYPATITE® PTFE** ball seats

Page 99 for Pressure-Temperature Ratings.

Page 44 for Construction and Materials.

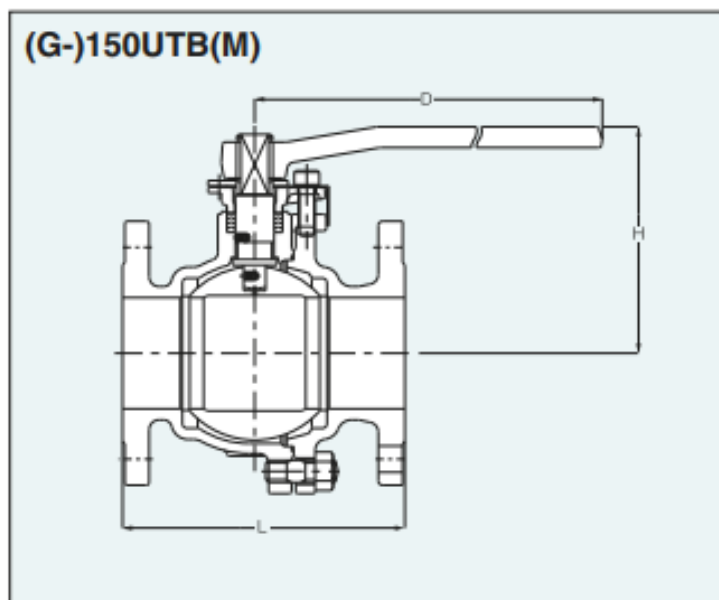

Dimensions of 150UTB(M)

Unit: mm

Nominal Size	NPS	1/2	3/4	1	1 1/2	2	2 1/2	3	4	5	6	8	10
	DN	15	20	25	40	50	65	80	100	125	150	200	250
Ball bore		15	20	25	40	50	65	80	100	125	150	200	250
L		108	117	127	165	178	190	203	229	356	394	457	533
H		102	105	124	113	120	154	163	197	217	291	350	Gear operation
D		130	130	160	230	230	400	400	460	460	1000	1500	Gear operation

Valve operator

NPS 1/2 to 8: Lever operation
 NPS 5 to 8: Optional gear operation
 NPS 10: Standard gear operation

Gear Operation

Unit: mm

Nominal Pressure	Class 150	Gear Operator			
		H	D	C	A
Nominal size (NPS)	5	312	310	165	65.5
	6	337	310	165	65.5
	8	414	360	210	88.5
	10	477	500	363	93.5

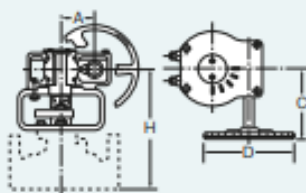

Worm gear operators may be mounted on KITZ ball valves at your option for the smoothest valve operation. Electric or pneumatic actuators are also optionally available. Contact KITZ distributors for appropriate choice and sizing of valve actuators.

Refer to "Product Range" on Page 1.