



DESIGNED TO PROTECT
**LIMITED AMOUNT OF
CASH AND VALUABLES**
FOR HOME AND SMALL
OFFICE SURROUNDING



ELECTRONIC HOME SAFE

BURGLARY- & FIRE-RESISTANT PROTECTION



KEY FEATURES

- Overall body thickness 43mm comprising of an inner and outer plate of tough steel filled with Chubb safes patented PCDE fire resisting barrier material.
- Overall door thickness 95mm comprising main door and lock casing. Main door 29mm thick filled with Chubb safes patented PCDE fire resisting barrier material.
- Door is secured by 3-way moving steel bolts measuring 25mm in diameter. (2 front, 1 top and 1 bottom moving bolt). A full length docking bolt secures the back edge of the door.
- Fire Resistance tested to a level corresponding to the Japanese Industrial Standard JIS S1037 : 1989 with fire resistance for up to 75 minutes
- A Polyurethane base paint finish is used to coat the body and door. The paint is both scratch resistant and durable.
- Power Source - 4 units of 'AA' size batteries.
- Battery Level indicator
- 5 minutes lockout feature should there be 3 unauthorized attempts to open the safe.

ELECTRONIC HOME SAFE

PRODUCT SPECIFICATIONS

External Height (mm) (A)	External Width (mm) (B)	External Depth (mm) (C)	Internal Height (mm) (D)	Internal Width (mm) (E)	Internal Depth (mm) (F)	Door Swing (G)	Depth with door at 90° (H)	Width when door fully open (I)	Nett weight (kgs)	Gross weight (kgs)	Capacity (Litres)
516	416	450	430	316	273	346	784	718	57	65	37

Note: Electronic lock furniture projection is 30mm

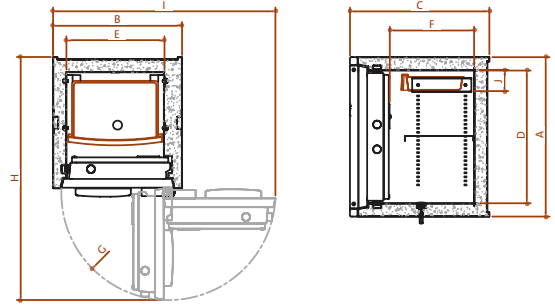

STANDARD LOCKING



ELECTRONIC LOCK

- User-friendly operation via a 6-digit electronic lock offering 1 million different codes
- Clear LED display screen with large keypad buttons
- Furniture projection: 30mm



OVERRIDING KEY

Usage of a 10 lever disc locks as an overriding key to access the safe if there is an accidental lockout or battery failures

INTERNAL FITTINGS

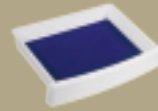

ABS DRAWER

Comes standard with velvet lining and brackets

SHELF

Comes standard with 1 adjustable shelf

FLOOR MOUNTING

Comes standard with base bolting facility, with 9mm diameter drop in anchor

Authorised dealer

GUNNEBO MALAYSIA SDN BHD
Suite 13A.01, Level 13A,
Menara Summit,
Persiaran Kewajipan USJ 1,
47600 Subang Jaya,
Selangor Darul Ehsan
Tel: 03-8024 3050
Fax: 03-8024 3051
Website: www.gunnebo.com.my
Email: info.my@gunnebo.com

www.chubbsafes.com.my