

氣壓式自動送料機

Air Feeder

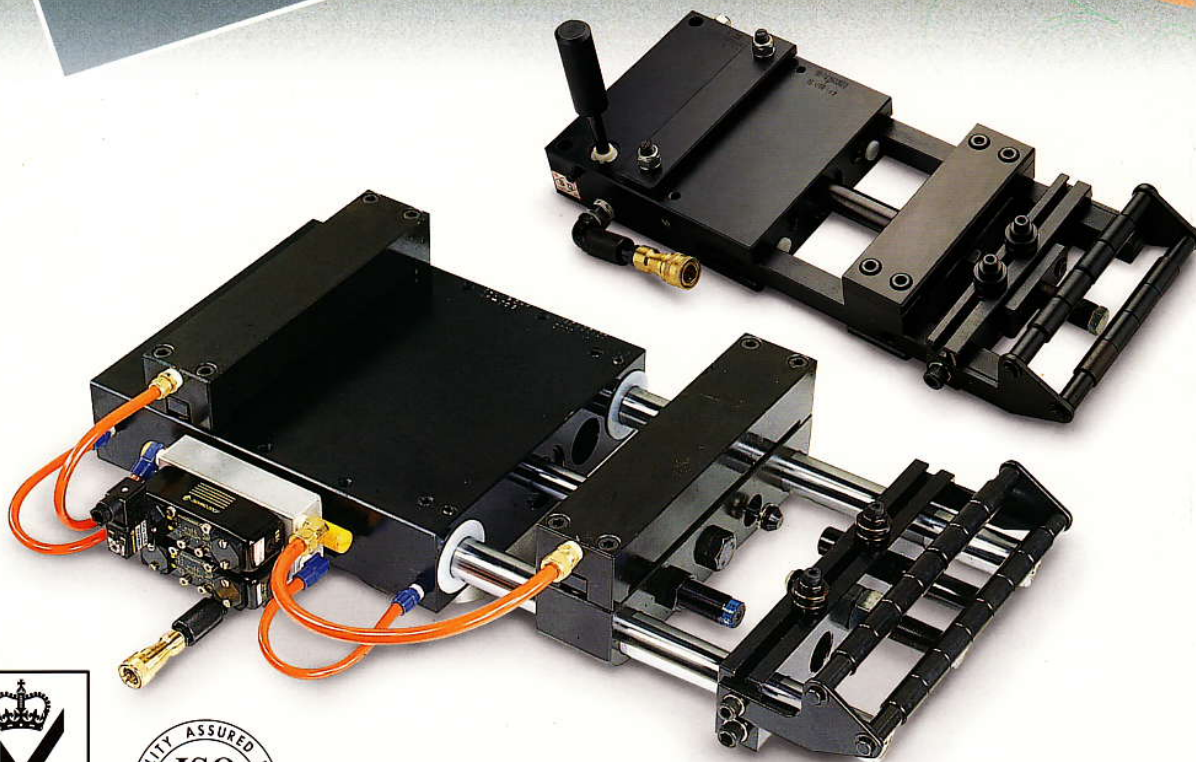
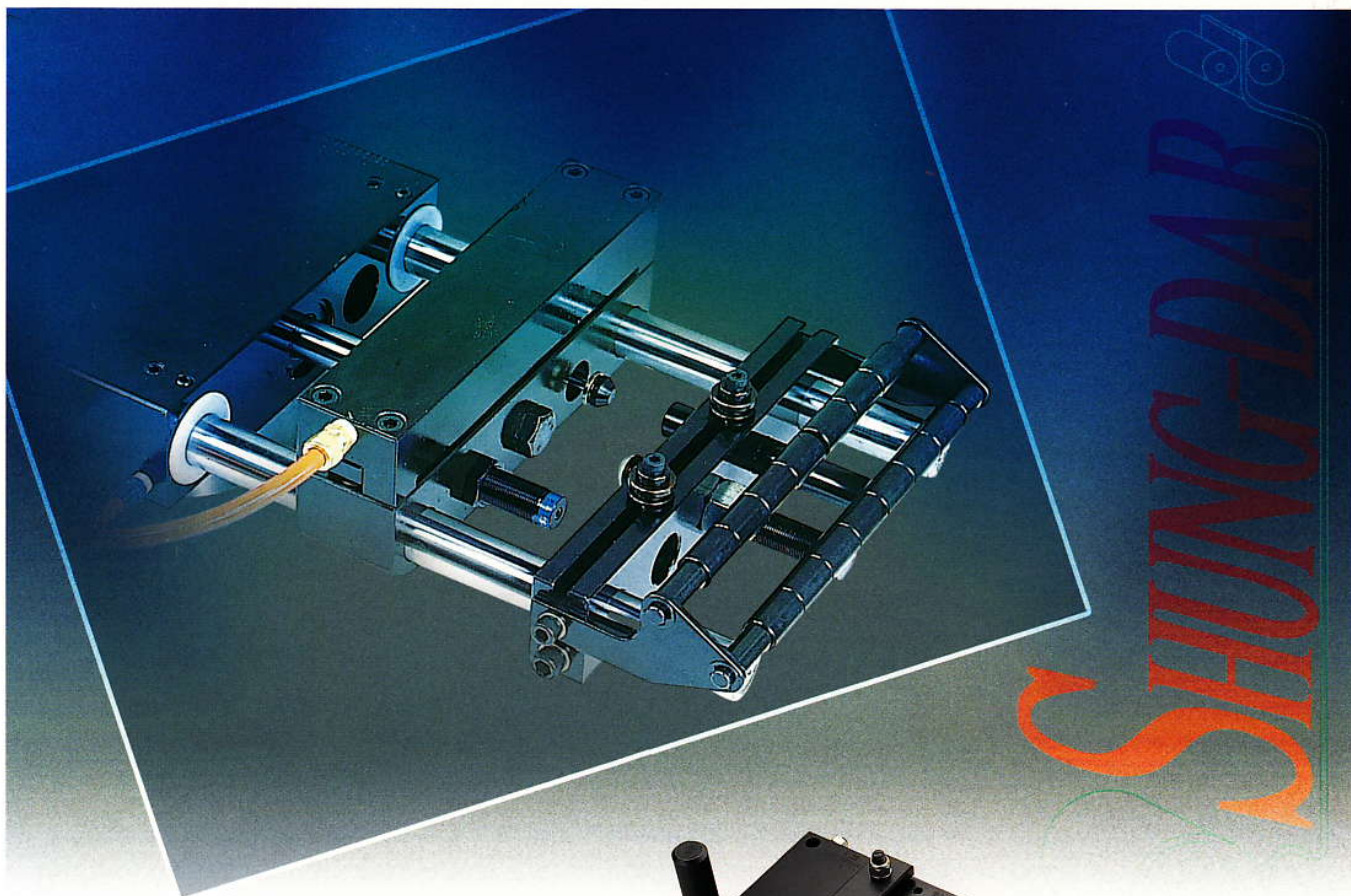

www.shungdar.com.tw

SHUNG DAR



標準型

- 送料長(寬) 0~450 mm。
- 送料厚度 0.1~3.0 mm。
- 可送材料種類：金屬、紙帶類、塑膠類。
- 可送材料形狀：圓形、三角形、突起物。
- 特別附件：AF-4CA以上附裝緩衝器。

STANDARD TYPE

Suitable for plastic and metal strip feeder capacity 0~450 mm width, 0.1~3.0 mm thick strips of round or irregular section special attachment: over AF-4C for extra force.

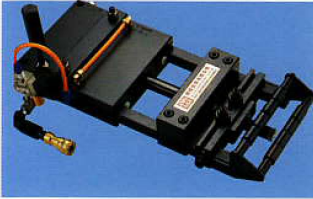

標準型加裝R型放鬆電磁閥

- 須高精密送料情況下，可利用電磁閥放鬆固定夾板以修正誤差。

STANDARD TYPE(AIR FEEDER)

can be set up a type release valve. It must be in used for high precision product feeding. Also, it may use R release valve to release the fixed clamp for correcting the tolerance of feeding material.

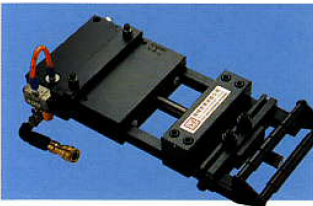

E型電磁閥

- 適裝於當沖床上下行程過短或過長距離送料的情形下。

E TYPE ELECTROMAGNETIC VALVE

If the press stroke were shorter or longer to feed material while it might be set up E type electromagnetic valve.



標準型加裝R型放鬆電磁閥E1型電磁閥

- 須高精密送料情況下，可利用電磁閥放鬆固定夾板以修正誤差，並且有夾料快，不損傷材料表面，可單獨動作之功用。

STANDARD TYPE(AIR FEEDER)

can also be set up both R type release valve & E1 type electromagnetic valve same time it must be in used for high precision product feeding also it may have same efficient as above (2) & (3).

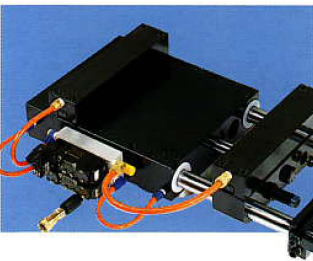

- 機型AF-7CS以上採用圓棒導軌，可提高耐磨耗性，以及直線精度。

The slideways on models over AF-7CS employs round guide for maximum wear resistance and added straightness accuracy.

SPECIFICATIONS 規格

MODELS 型式	AF-2CS	AF-3CS	AF-4CS	AF-5CS	AF-6CS	AF-7CS	AF-8CS	AF-9CS	AF-10CS	AF-11CS	AF-12CS
Maximum width (mm) 最大送料寬度	60	80	100	150	200	250	300	350	400	450	500
Maximum length (mm) 最大送料長度	70	80	125	150	200	250	300	350	400	400	450
Thickness of material (mm) 材料厚度	0.8	1.2	1.5	2	2	3	3	3	3	3	3
Air pressure (kg/cm ²) 空氣壓力	4.5	4.5	4.5	4.5	4.5	4.5	4.5	4.5	4.5	4.5	4.5
Maxi. feeding speed (s.p.m.) 最大送料速度	200	180	130	100	80	55	50	40	40	40	40
Fixed clamp force (kg) 固定夾板夾持力	30	45	60	85	85	120	120	123	123	123	123
Movable clamp force (kg) 移動夾板夾持力	53	68	85	155	178	200	217	220	245	245	245
Tension (mm) 引張力	16.5	19.5	25.5	41	41	67	74	77	85	85	85
Air consumption (ℓ/min.) 空氣消耗量	32	42	53	105	105	132	130	152	165	175	185
Weight including tools (kg) 重量(包含工具)	9.6	12.8	19.6	38.4	52.4	80	95	156	178	200	230

- All specifications, dimensions and design characteristics shown in this catalogue are subject to change without notice.
- 本公司隨時進行研究改善的工作，因此本型錄內所示之尺寸及設計特性，得以變更，恕不另行通知。

NC Roll Feeder (NC滾輪送料機)



NBF

Series / 300 · 400 · 500 · 600 · 800 · 1000 · 1300



NCF

Series / 200 · 300 · 400 · 500 · 600

Excellent Human Feelings & Affection!

SHUNG DAR



CE

Features:

- The machine use NC servo driving motor, close-loop control design to prevent outside interference. Using interface control panel for easy operating and setting feeding parameter to reach ultra feeding accuracy.
- Compact styling machine design with heavy rigid structure, easy maintenance and long service life. This is newly developed based on our long term accumulated know-how.
- Local customers available for reference.
- Value for money.
- Quality at the lowest prices.

特性:

- 本機採用NC伺服馬達驅動，全閉式人機迴路設計，減少傳輸時的外部干擾，採用人機介面操作，各種送料尺寸，皆可在面板上輕鬆設定，達到高精度送料需求。
- 機身美觀一體成型，結構精密鋼強，維修簡便，壽命長，為本公司累積長期經驗開發而成。

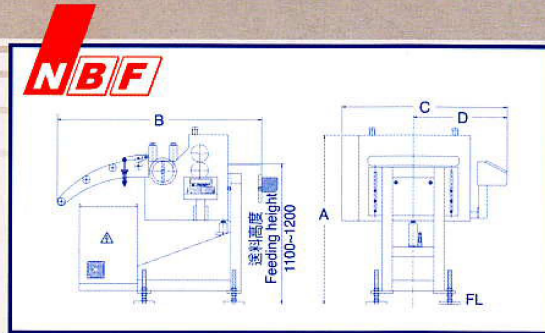

Machine dimensions 機械外觀尺寸

Models 型式	A	B	C	D
NBF-300	1230	1480	895	525
NBF-400	1230	1480	995	575
NBF-500	1230	1480	1095	625
NBF-600	1230	1480	1195	675
NBF-800	1230	1480	1395	775
NBF-1000	1230	1480	1595	875
NBF-1300	1230	1480	1895	1025

Specifications 規格

Models 型式	NBF-300	NBF-400	NBF-500	NBF-600	NBF-800	NBF-1000	NBF-1300
Coil thickness 板厚(mm)	0.6-6.0	0.6-6.0	0.6-6.0	0.6-6.0	0.6-6.0	0.6-6.0	0.6-6.0
Coil width 板寬(mm)	~300	~400	~500	~600	~800	~1000	~1300
Feeding capacity 送料能力(mm)	6.0 x 300	5.0 x 400 6.0 x 300	4.0 x 500 6.0 x 270	3.5 x 600 6.0 x 270	3.2 x 800 6.0 x 250	2.5 x 1000 6.0 x 250	2.3 x 1300 6.0 x 200
Feeding length 送料長度 (mm)	9999.99	9999.99	9999.99	9999.99	9999.99	9999.99	9999.99
Feeding nighth adjust 送料高度調整度(mm)	70-140	70-140	70-140	70-140	70-140	70-140	70-140
Max. feeding speed 最快送料速度(m/min)	20	20	20	20	20	20	20
Power source 電源電壓(v)	200 / 220V	200 / 220V	200 / 220V	200 / 220V	200 / 220V	200 / 220V	200 / 220V

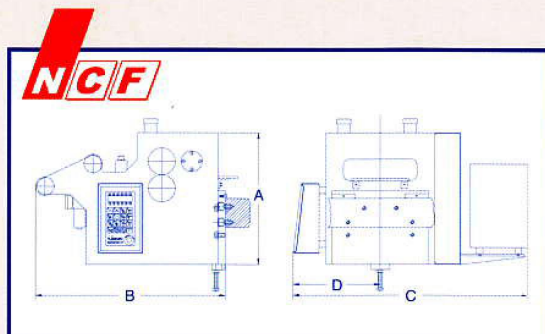

Machine dimensions 機械外觀尺寸

Models 型式	A	B	C	D
NCF-200	440	570	730	270
NCF-300	440	570	830	320
NCF-400	440	570	930	370
NCF-500	440	570	1030	420
NCF-600	440	570	1130	470

Specifications 規格

Models 型式	NCF-200	NCF-300	NCF-400	NCF-500	NCF-600
Coil thickness 板厚(mm)	0.2-3.2	0.2-3.2	0.2-3.2	0.2-3.2	0.2-3.2
Coil width 板寬(mm)	~200	~300	~400	~500	~600
Feeding capacity 送料能力(mm)	0.3-2.0 x 200 3.2 x 100	0.3-2.0 x 300 3.2 x 120	0.3-2.0 x 400 3.2 x 150	0.3-1.6 x 500 3.2 x 200	0.3-1.6 x 600 3.2 x 250
Feeding length 送料長度(mm)	9999.99	9999.99	9999.99	9999.99	9999.99
Feeding nighth adjust 送料高度調整度(mm)	70-140	70-140	70-140	70-140	70-140
Max. feeding speed 最快送料速度(m/min)	20	20	20	20	20
Power source 電源電壓(V)	200 / 220V	200 / 220V	200 / 220V	200 / 220V	200 / 220V

· Note: Right of modification reserved.
· 本公司不斷設計研發改善現有機型，若與此目錄所示不符，恕不另行通知。