



ARIAZONE 5001 FAHDF (R134a Data & Flush)

Automotive Air Conditioning Service Station

OPERATOR MANUAL



Contents	Page
1. Introduction	3
2. SAFETY FIRST! Important Safety Information's	4
3. Technical Features	5
4. Main Parts & Features	6
5. Preparing the Machine for the First Use	8
6. Printer	11
7. Refrigerant Cylinder Filling Procedure	12
8. Connecting to the A/C System	13
9. Individual (Manual) Function Selection Procedure	14
9.1. Recovery & Recycling Mode	15
9.2. Evacuation Mode	17
9.3. Oil / UV Dye Injection Mode	18
9.4. Refrigerant Charge Mode	19
10. Automatic Cycle Selection Procedure	20
11. Flushing the A/C system with refrigerant	23
12. Cylinder Air Purge	26
13. Service Procedure	27
14. Unit Settings	28

1. Introduction

Fully Automatic Air Conditioning Service Station is a user-friendly tool specifically designed for the automotive air-conditioning technicians, to carry out the following functions:

- **Testing air-conditioning system by comparing pressure readings on HP and LP gauges,**
- **Recovery & Recycling the refrigerant from air-conditioning system and gauge amount of refrigerant and oil (if any) recovered from air-conditioning system,**
- **Evacuate air-conditioning system,**
- **Electronically charge lubricating oil by weight into the air-conditioning system,**
- **Electronically charge UV Dye by volume into the air-conditioning system,**
- **Electronically charge refrigerant into the air-conditioning system by weight,**
- **Flushing (cleaning) the air-conditioning system with refrigerant.**

The unit is suitable for servicing passenger and light commercial vehicles air-conditioning systems



This is a microprocessor control system which provides electronically controlled functions, whilst keeping the operator constantly informed and in full control.

This unit has been designed and build to be long lasting and with high level of reliability including maximum safety for the operator. The operator needs only to be responsible for the proper use and maintenance of the unit, in accordance with the instructions found in this manual.



Important: This manual contains important information pertinent to operator safety, and must accompany the unit, in the case of sale or transfer to another party.

Manufacturer reserves the right to modify this manual and the unit itself at any time without prior notice.



Environmental information

This product may contain substances that can be hazardous to the environmental or to human health if it's not disposed of properly.

Electrical and electronic equipments should never be disposed of in the usual municipal waste, but must be separately collected for their proper treatment (recycling).

We also recommend that you adopt appropriate measures for environmental protection: recycling of the internal and external packaging of the product, including batteries (if any).

With your help it is possible to protect our planet and improve the quality of life, by preventing potentially hazardous substances being released in to our environment.

2. Important Safety Information's

This unit is extremely simple and reliable in selecting and performing all its functions. Therefore, the user is not exposed to any risk, if the general safety guidelines reported below are followed, in association with proper use and maintenance of the unit (improper use and maintenance will reduce the safety of the unit).

This equipment is to be operated by accredited technician only! Users must have basic knowledge of air-conditioning and refrigeration systems, including potential hazards associated with the handling of refrigerants and systems under high pressure.



Read this user manual carefully before start up, connecting and operating the unit. If you do not understand any section of this manual, please contact your nearest distributor or manufacturer.



Handle refrigerant with care as serious injury may occur. Always **wear appropriate protective safety gloves**.



The contact with refrigerant can cause blindness. Always **wear appropriate protective safety glasses**.

- **Avoid inhalation of the refrigerant.** Use only in well ventilated work areas.



- The power cable may only be connected to a socket with nominal voltage stated on the rating plate, located at the rear of the unit.

- **RISK OF ELECTRICAL SHOCK.** Power lead plug to be connected only to power point with an earth.

- Never operate the equipment with a damaged power lead, replace it immediately. Before removing any protective cover from unit, always unplug power lead from power point.



- **Use only pure R134a** refrigerant with this equipment.

- The unit should not be operated with flammable refrigerants (HC of R1234yf).

- Position the unit on all four wheels, on a flat (horizontal) surface so that proper operation of the scales is guaranteed.

- Do not expose the machine to direct artificial heat or rain.

- Do not tamper with or change safety control devices or their settings.

- When (if) transporting the unit, keep upright and if possible remove refrigerant cylinder from platform.

- Do not cover ventilation openings on chassis cover when the unit is operating.

- Maintenance is to be carried out as per the manufacturer recommendation shown in this manual. Only original parts are to be used for maintenance and repairs. Maintenance of the unit must only be performed by an authorized technician.

- Only non aggressive substances to be used for cleaning of the unit.

3. Technical Features

Refrigerant	R134a
Electronic refrigerant scale	+/- 10 g resolution
Load cell	60kg with 150% overload capacity
LP and HP gauges	D 68 mm kl.1.0
Recovery cylinder	27kg
Recovery pump	FR11G, 275W
Recovery rate	up to 400 g/min (liquid state)
Vacuum pump	2 stage, 100 l/min (3.5cfm)
Vacuum	3×10^{-1} Pa
Dimensions	620 mm, 600mm, H-1120 mm
Weight	84 kg
Chassis	Sturdy all steel construction, powder coated
Supply voltage	220-240VAC - 50/60Hz
Power	700 W
Max. Currency	6.7A
Working conditions	0 to 45 °C ambient temperature, up to 100% humidity, 2000m altitude
Noise level	< 70 dB (A)
Fuse	10 amp/250V (slow blow type)
Measuring instrument	I category (Not to be mixed with II, III, IV category)
Approvals	EN 61010-1 Electric safety, EN 55014-1 EMC-CE

4. Main components location

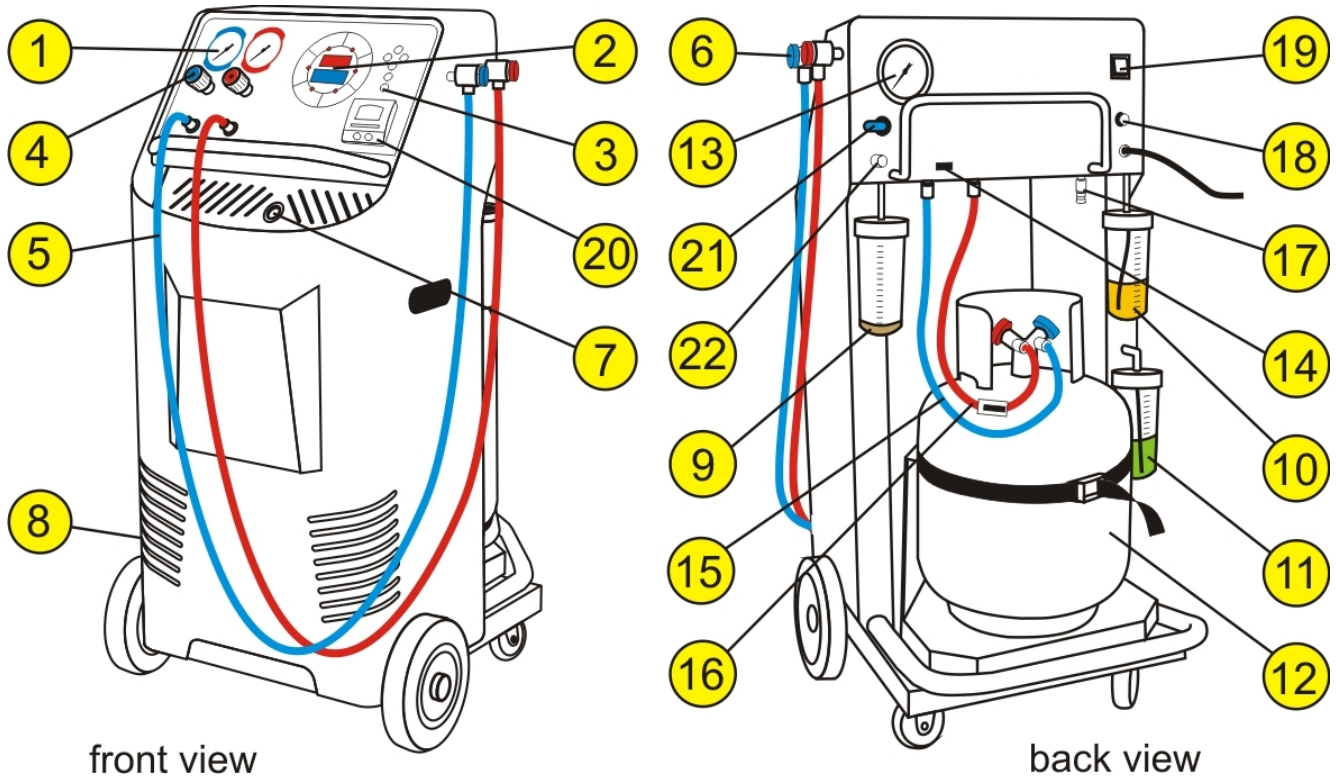

1. Low Pressure and High Pressure gauges - Two large analogue gauges display suction and discharge pressures. The gauges are mounted on the front panel for easy viewing by the operator. Pressures are displayed in Bar & PSI and temperatures in degrees Celsius.

2. LED & LCD Displays - LED numerical display and LCD display below inform the operator on weight of refrigerant and oil currently in the unit vessels, remaining vacuum time, the amount of refrigerant and oil being recovered or charged, data base of vehicles and unit set up...

3. LED group and membrane switches (keys) - Six LED indicates the mode and status of the unit. These are used in conjunction with 6 membrane switches (keys) to select the unit functions. Further, once the mode is in operation the pattern in which the Led's flash, indicate the activity of the system. These can be viewed from several metres away.

4. Hand Valves - The console hand manifold valves allows the operator to control the flow of the refrigerant (if desired).

5. Discharge & Suction Service Hoses - A pair of 3m hoses are connected to the console, which allows the operator to connect the system to the vehicle air-conditioning system service ports for testing system pressures, recovering and recharging refrigerant, oil and/or UV dye.

6. Service Hose Quick Couplers - Service hose quick couplers allows the operator to connect the unit to the vehicle air-conditioning system service ports, without exhausting the refrigerant in to the environment.

7. Moisture Indicator - The moisture indicator is conveniently mounted below the console for added protection to indicate the condition of refrigerant and filter change intervals. The following colours correspond to the following moisture content: Green or Blue Dry, Yellow or Pink Wet.

8. Vacuum Pump Oil Level - Oil level must be checked when the pump is running, the oil level should be even with the horizontal line on the vacuum pump sight glass. Under filling with oil will result in poor vacuum performance. Overfilling can result in oil blowing out from the vacuum pump exhaust.

9. Recovered Oil Drain Reservoir - Plastic vessel of 250ml is mounted on the right rear of the unit to electronically gauge the amount of oil recovered from the air-conditioning system, if any.

10. Oil Storage Reservoir - Plastic vessel of 250ml is mounted on the left rear of the unit to electronically inject the recovered amount of oil back in to air conditioning system, or to select the desired amount of oil to be injected.

11. UV DYE Storage Reservoir - Plastic vessel of 250ml is mounted on the lower left rear of the unit (below the Oil Reservoir) to electronically inject UV Dye in to air- conditioning system.

12. Refrigerant Cylinder - 27kg capacity cylinder is used to store the recovered/recycled refrigerant. The cylinder is secured with strap to the platform.

13. Cylinder Non-Condensable Indicator - A large pressure gauge is mounted on the back upper left side of the unit to indicate to the technician of any non-condensable (air) built up in the storage cylinder.

14. USB port – Connection with PC

15. Cylinder Vapour Hose (Blue) - Connecting the cylinder vapour valve (blue) with the unit

16. Cylinder Liquid Hose (Red) with Ball Valve - Connecting the cylinder liquid valve (red) with the unit

17. Brass Adapter – For connection of the suction service hose (5) to a storage refrigerant cylinder valve.

18. Power Lead with Fuse - 10A

19. Main Power Switch

20. Printer - After completion of every operation the unit will print a report

21. Cylinder Air Purge Ball Valve - To purge the non-condensable gases (air) from the cylinder (12) and bring back the pressure to the recommended chart values.

22. Flushing port – ¼" SAE male adapter with Schrader valve.

5. Preparing the Machine for the First Use

Perform the following steps to prepare the unit before the first use.

1. Remove the **shrink wrap and styrofoam** insert behind the cylinder (12) (see figure 1).



2. Check to ensure that all of the accessory components are with the unit:

- Cylinder (12)
- Adapter (17)
- Cylinder vapour hose (blue) (15)
- Cylinder liquid hose (red) with ball valve (16)
- Service hoses with quick couplers (5)
- User's manual
- Cylinder strap



3. Check that the cylinder (12) is already placed on the platform and properly secured with the strap provided. Unscrew two securing M6 bolts situated on each side of the platform base app. 3-4 mm and LOCK the locking nut, making sure that there is 3mm clearance between the end of the safety bolt and the base of the machine.



4. Check the vacuum pump oil level (8).

The oil level should be even with the horizontal line on the vacuum pump sight glass when the pump is running.

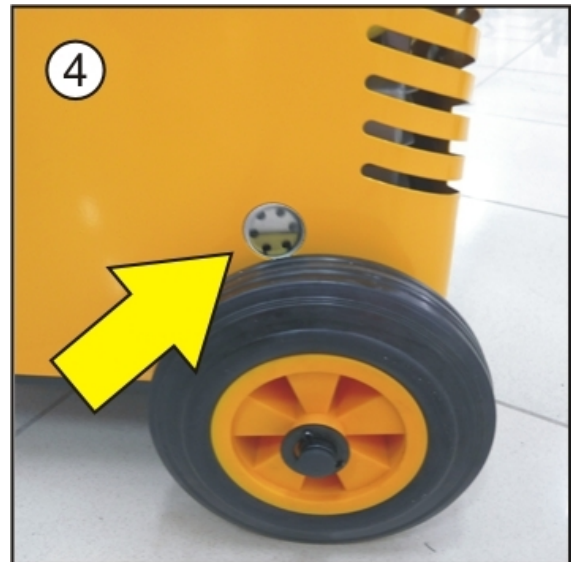

5. Power up the unit on a main switch (19).

The unit will perform a lamp test, whereby all LED displays are illuminated. This will enable the operator to determine if any display segments have failed.

After the sequence has been completed, the displays will indicate: **FILT - REMAINING WORKING HOURS XX Hr.**

This is the number of hours left before equipment servicing is required.



6. In next sequence the unit is on "Stand by" and the LCD display is showing:

- The amount of refrigerant in the cylinder (12),
- The quantity of new oil in the vessel (10).
- The quantity of oil in recovered oil vessel (9)
- The time is displayed

If the cylinder is delivered empty, display should indicate approximately 0.00kg of refrigerant in the cylinder (cylinder empty).



7. Mode Selection.

To select a mode of operation, press either the "UP" or "DOWN" arrow keys until the LED indicator is beside the desired function.

Press 'START' key which will cause the unit to enter the selected mode. Any mode that has been selected can be exited by pressing the 'STOP' key.

Note, that if a valid key was depressed, the unit will beep. If an inappropriate selection has been made, i.e. attempting to select a mode whilst another mode is in operation, the unit will ignore the pressed key and will not beep.



8. Check if both cylinder (12) valves and liquid hose (16) ball valve are open.

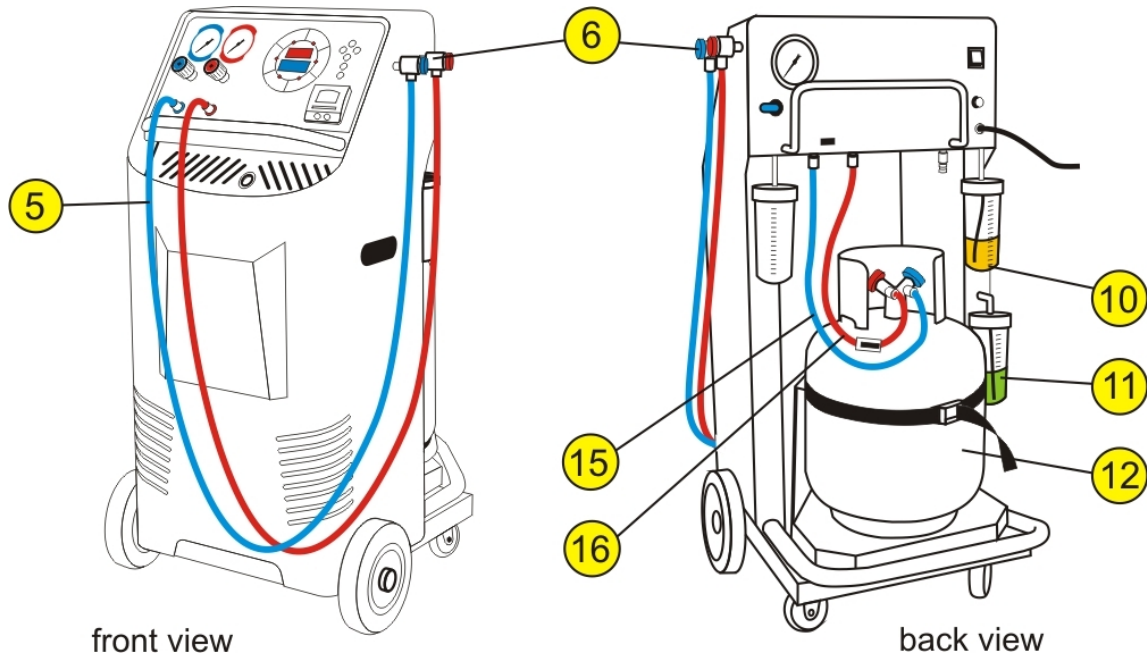

9. Attach the service hoses (5) on the unit. Carefully tight (with fingers only) knurled nut on console bellow hand wheels (blue-left, red-right). Hook up quick couplers (6) to parking brass adapter (pull back bottom knurled section with fingers and carefully press the coupler into the proper adapter).

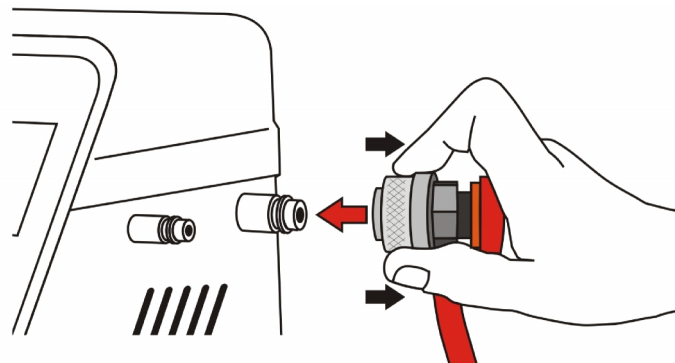

10. Fill the plastic oil vessels (10) with new oil (minimum 50ml) and plastic vessel (11) with UV Dye (minimum 50ml). The display in Stand by mode will show the amount of the oil filled in new oil injector.

6. Printer

The printer is equipped with two keys and green led:

- >> Paper feed
- II on line / off line

The green led shows the state of the printer:

Led constantly ON - Printer in line

Led blinking - Printer not in line or no paper

Led off - Press II. If the problem persists, contact authorized distributor or manufacturer.

Printer roll specifications,

Paper width: 57-58mm

Max paper thickness: 80 µ

Printing report:

After completion of every operation the unit will print a report as per list on the right --->

REFRIGERANT RECOVERY
g. 550
VACUUM
min.20
RECOVERED OIL
ml 10
OIL INJECTION
ml 10
UV DYE INJECTION
doses 1
REFRIGERANT CHARGED
g.650
Date: 05.06.08
Time: 10:45
CLIENT: _____
CLARK AUTO SERVICE
Sabre Court 3-5,
MELBOURNE
T: +61 3 9338 7522
F +61 3 9338 7811

How to open printer cover



How to load paper load



How to close the cover



7. Refrigerant Cylinder Filling Procedure (Refrigerant Transfer)

The cylinder (12) may be filled with refrigerant by the following procedures.

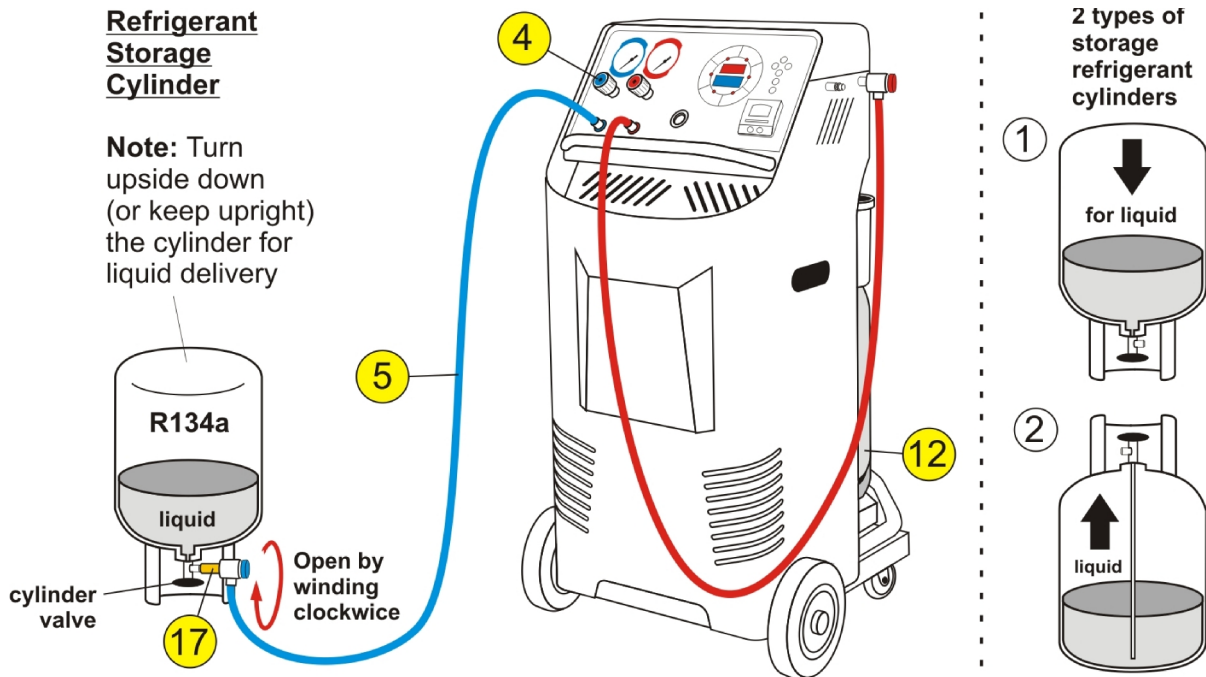

Connect the suction (blue) service hose (5) to storage cylinder liquid valve by using the refrigerant cylinder adapter (provided from refrigerant supplier), open liquid valve on storage cylinder, open service hose quick coupling (5) and console blue hand valve (4)...

Press "UP" key once to select the RECOVERY / TRANSFER function and press "START". By using "DOWN" key select TRANSFER (REFRIGERANT) and press "START".

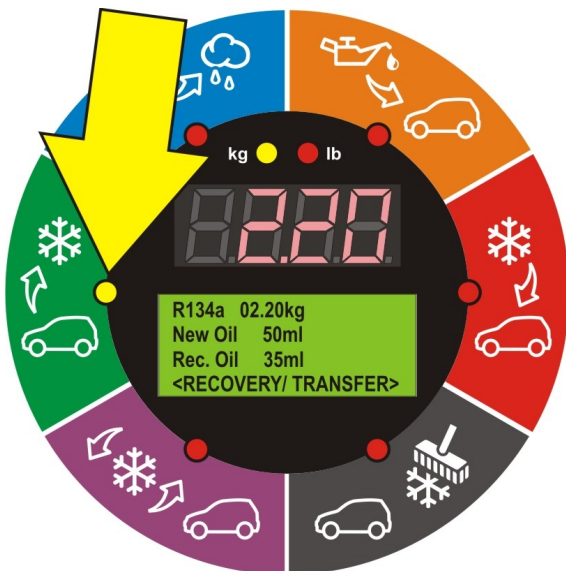

<SET RECOVERY MODE>
TOTAL RECOVERY
PARTIAL RECOVERY
TRANSFER

Now, select from two options:
 - TOTAL TRANSFER (all refrigerant) or,
 - PARTIAL TRANSFER (set the amount of refrigerant to be transferred).

<SET TRANSFER MODE>
TOTAL TRANSFER
PARTIAL TRANSFER

Press "START" key and unit will automatically transfer refrigerant from storage cylinder to the unit cylinder (12).

When the selected amount of refrigerant is transferred, close the storage cylinder valve and allow the unit to recover the refrigerant from the service hose (5). Once the function is completed the unit will display symbol "DONE" and the amount of refrigerant transferred will be displayed in kg or lb on main display (2).



Important: Always keep a minimum of 2 kg in the cylinder (12).

8. Connecting to the A/C system

Use the service hose (5) quick-connect couplers to connect the hoses to the A/C system service ports, bearing in mind that BLUE must be connected to the low-pressure (suction) side and RED to high pressure (discharge) side.

If the system is equipped with a single service port, connect only the relative hose.

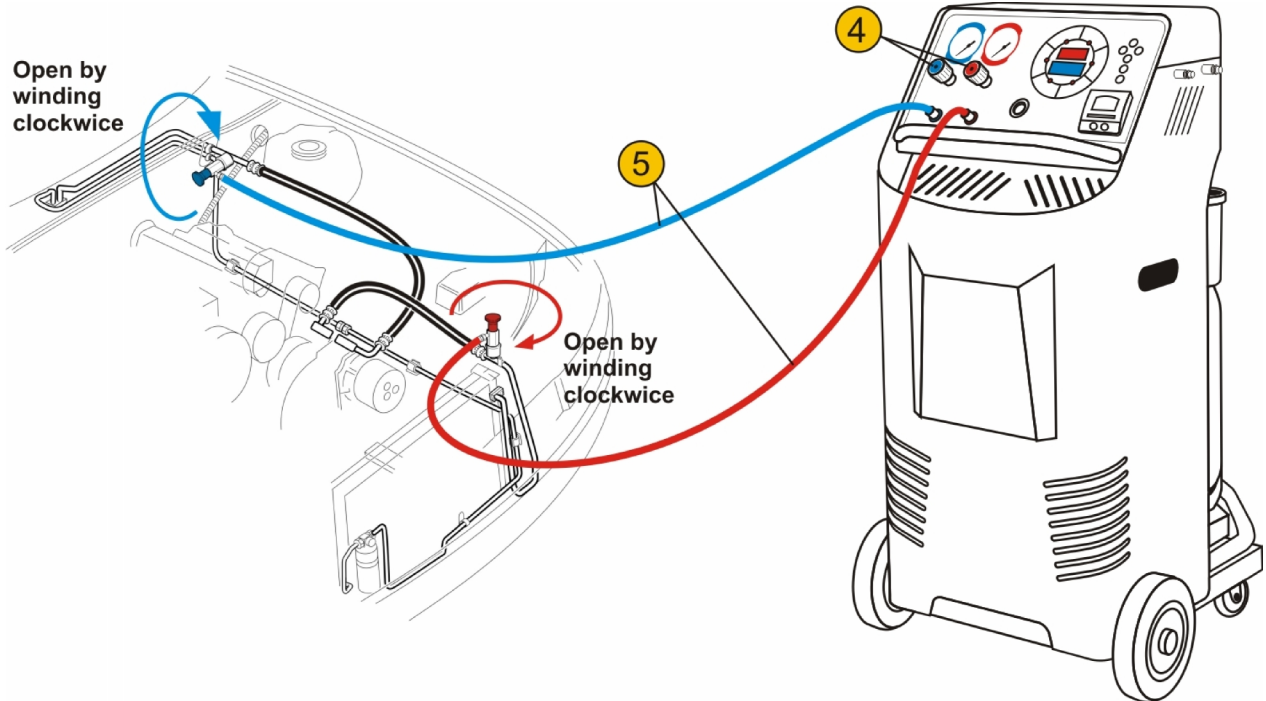

Winding the quick coupler hand wheel clockwise will allow the refrigerant to flow through the hoses. Turning hand wheel in opposite direction, the flow will be closed. If there is any refrigerant in the air-conditioning system, the pressure gauges will indicate a pressure rise.



Important: Console manifold hand valves (4) need to stay closed, NOT to allow refrigerant to enter into the unit until the required function has been selected.

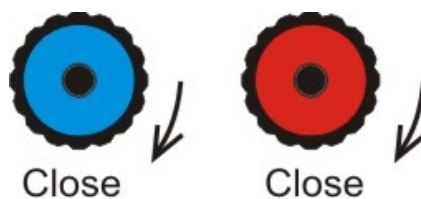

The unit gauges (suction & discharge) are important and useful instruments. The operator should have basic understanding between gauge reading and air-conditioning system operation in order to correctly diagnose any possible system malfunction.



Set the transmission in neutral - park, start engine and turn the air conditioning on. Allow pressure gauge needles to stabilize and record the pressure readings.

Gauges reading may show particular problem or associate to a possible problems.

9. Individual (Manual) Function Selection Procedures

With this procedure, all functions:

- Refrigerant recovery & recycling,
- A/C System Evacuation,
- New Oil and/or UV Dye Injection and
- Refrigerant Charge)

can be performed individually (step by step).

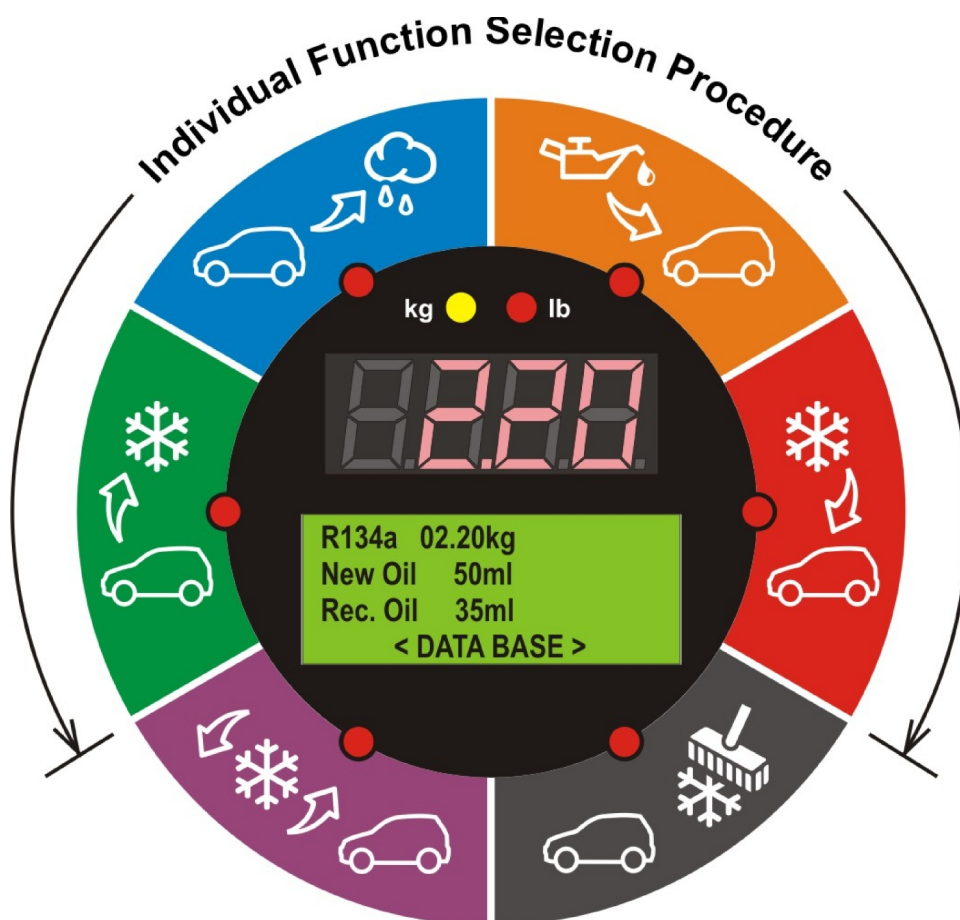

The values for the quantity of refrigerant recovered, quantity of the oil recovered, vacuum time, quantity of oil injected and quantity of refrigerant charged into the a/c system are automatically printed at the end of each single operation.

9.1. Recovery & Recycling Mode

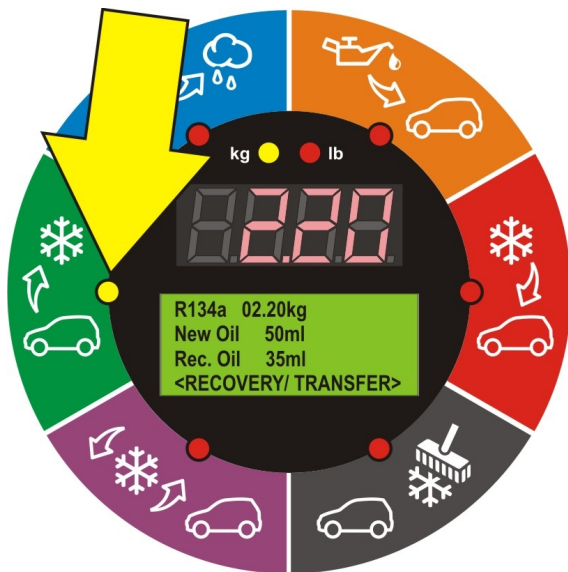

The purpose of the Recovery & Recycling mode is to recover refrigerant from the air conditioning system, which will condense, purify and store the liquid refrigerant in the storage cylinder ready for re-use.

To initiate the Recovery mode, press the 'UP' key once, followed by 'START' on the console. Display will show:



1. **TOTAL RECOVERY** to recover the whole amount of the refrigerant from the A/C system or storage cylinder.
2. **PARTIAL RECOVERY** to select **desired** quantity of refrigerant to be recovered from the a/c system or storage cylinder.

After the quantity selection is made, press "START" key.

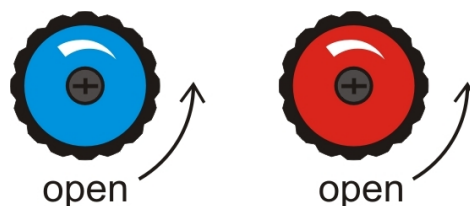

Important: Open the hand manifold valves (4) on the console to allow the flow of the refrigerant from the a/c system before making the above selection (valves on the unit storage cylinder (12) and ball valve on the cylinder liquid hose (16) must be open also).

During the recovery process, the 'Recovery' mode LED indicator will blink and the display (2) will indicate the amount of refrigerant being recovered.

In normal operation the above condition will be maintained until a vacuum of -0.4 bar is reached at either the discharge or suction ports. When this occurs, the machine will beep once, and the unit will enter in Recovery "PAUSE" mode. In this mode, the unit will shut down the Recovery function and pause for 180 seconds, in which during this time the recovery mode enunciator will be ON constantly. The display (2) will indicate "PAUSE". During this function, the unit is monitoring whether the air-conditioning system pressure is increasing, due to any refrigerant that may be left in the a/c system. If the pressure increases above zero, the machine will re-start the recovery function automatically and recover the remaining refrigerant.

If at the end of Recovery process a sufficient vacuum of -0.4 Bar has been maintained, the unit will stop, and the display (2) will indicate 'DONE' and the amount of refrigerant recovered will be displayed in kg (or lb) depending on the operator's selection.

Press 'STOP' on the console, the unit will display "busy" for 5 seconds. The value of the quantity of refrigerant recovered will be automatically printed.

9.1.1. Recovered Oil Drain

After completing the recovery function, the unit will automatically drain the recovered oil (if any) into recovered oil vessel (9) to electronically calculate amount of oil that has been recovered. The value of the recovered oil will be automatically printed.

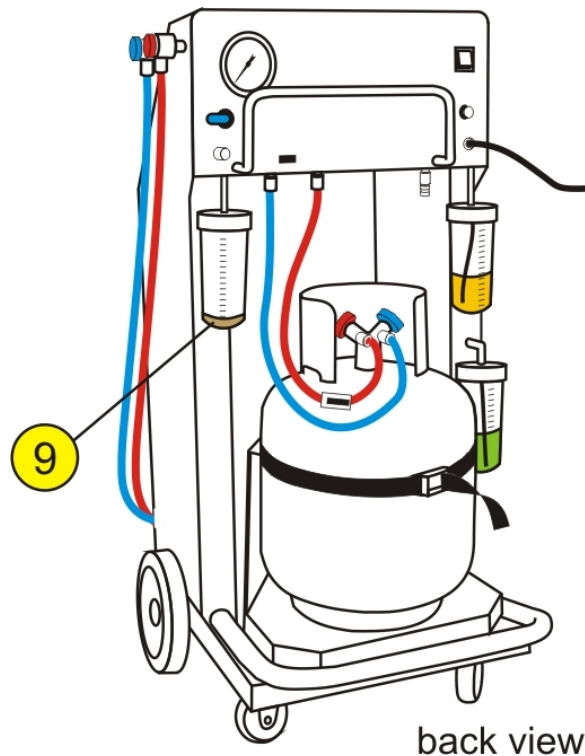

9.1.2. Conditions that will stop the recovery mode

The above sequence assumes that neither the stop button was pressed, or that no undesirable condition occurred. The following conditions will cause the unit to halt the recovery function.

1. If hand m-fold valves (4) on the console are CLOSED. "NO REF" will be displayed.
2. Air conditioning system empty. If the A/C system pressure is not above atmospheric pressure, the recovery function will not be activated. "NO REF" will be displayed.
3. Refrigerant cylinder (12) full. To protect the storage cylinder from being overfilled, the unit will not allow the operator to recover refrigerant once it has reached 80% of its capacity. "CYL FULL" will be displayed.
4. High Pressure. If the operating pressure of the unit exceeds 25 bar (340 PSI), the unit will stop and display 'HiGH - PRES'. The following can cause the above:
 - Cylinder (12) valves not open.
 - Restricted cylinder hose (16). Check the ball valve.
 - Excessive high ambient temperatures.
 - Excessive air in refrigerant cylinder (12).
 - Faulty pressure control

In all the above circumstances, press the 'STOP' key to return to the machines initial mode. If the above conditions are ok and the 'H-PRES' display keeps on appearing, contact your local distributor or manufacturer for further advice.

5. Recovered oil vessel (9) full.

9.2. Evacuation Mode



In the evacuation mode the air and moisture in the air conditioning system is removed and exhausted to the atmosphere. The evacuation mode runs for a predetermined time selected by the operator.

To initiate evacuation mode, press the 'UP' key twice, followed by the 'START' key. Select the desired evacuation duration by pressing the 'UP' key to increase or 'DOWN' key to decrease time duration. Once the desired time has been selected, press the 'START' key and the function will commence.

The evacuation time can be set from one minute to eight hours. At any time the evacuation time can be paused or cancelled by pressing the "STOP" button once to pause, or twice to cancel the function.



Important:

During evacuation mode the manifold hand valves (4) on the console must be open.

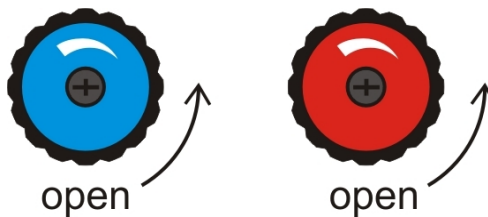

The unit has a unique function that if the evacuation function is selected and there is residual refrigerant in the air conditioning system, greater than 0.5 Bar (10 PSI), the unit will detect this condition, whereby it will beep six times to warn the operator. After this warning the unit will automatically recover the residual refrigerant, once it has recovered the entire refrigerant it will start the selected evacuation function automatically.

Leak Test - If the vacuum of min -0.85 Bar is not reached after first 90sec, the unit will beep and display TEST FOR LEAK, indicating for possible leak in the a/c system or bad connection of the service hoses.

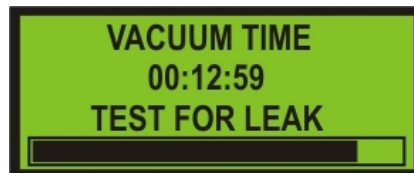

In Normal operation after completion of evacuation function, next 3 minutes the unit will test if there is leak in the a/c system. Depends if the a/c system is leaking or not, the display will show OK or FAILED.

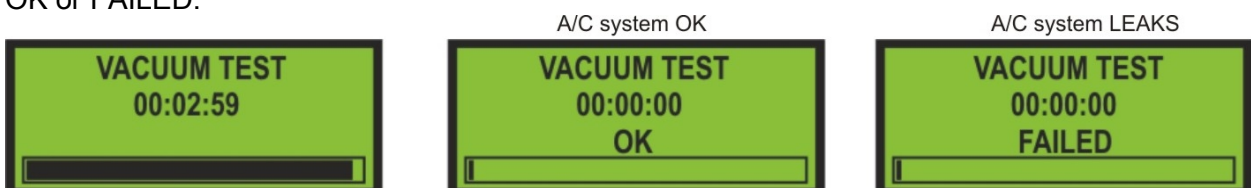

After completion of evacuation function, the unit will automatically print the report.

9.3. Oil & UV dye Injection Mode

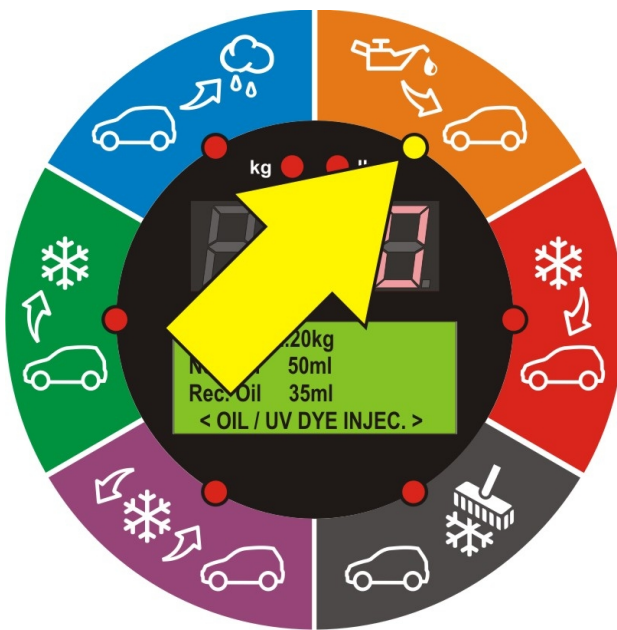

The purpose of this function is to batch a user-defined quantity of refrigerant oil or UV dye from the oil reservoir (10) to the vehicle air-conditioning system.



Important: The unit requires that the air conditioning system has previously been evacuated to a maximum vacuum before this function can be carried out.

Make sure you have sufficient refrigerant oil and UV dye in the vessels (10 & 11) and select the Oil/UV Dye Injection mode by pressing the 'UP' or 'DOWN' keys, followed by the 'START' key. Now the display will show the following:

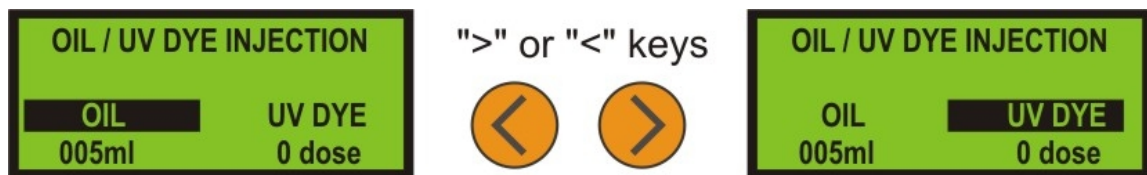

Select the desired amount of refrigerant oil ('UP' key to increase or 'DOWN' key to decrease the volume). With ">" key go to UV DYE and again with "UP & DOWN" keys select the desired number of UV Dye doses (1 dose ~ 8ml). Once the desired amount has been selected open hand manifold valve (4) on the console and press the 'START' key.



Important: During evacuation mode red HP hand valve (4) on the console must be open.

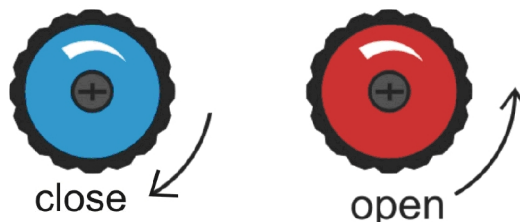

After completion of oil injection, the unit will automatically print the report of the oil injected into the A/C system.

9.3.1. Conditions that will stop oil injection

The unit will not inject oil if the following conditions exist:

- Insufficient vacuum.
- Hand manifold valves (4) **not opened** on console.
- No oil in the reservoir (10).

9.4. Refrigerant Charge Mode



The purpose of the refrigerant charge mode is to batch a user-defined weight amount of refrigerant into the air-conditioning system.



Important: Before start refrigerant charge A/C system MUST be properly evacuated and leak tested.

To initiate charging mode, press the 'UP' key four times, followed by the 'START' key. The display will show the following

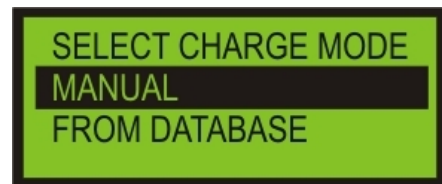

Select the desired charging mode MANUAL or FROM DATABASE and set the amount of refrigerant to be charged into the a/c system (with 'UP' key to increase or 'DOWN' key to decrease in manual mode, or by selecting the vehicle make and model from database). The smallest increment of refrigerant charge weight is 0.01 kg. Holding the 'UP' or 'DOWN' keys for longer than two second will cause the increments of weight change to increase or decrease rapidly.



Important: Once the refrigerant charge weight has been set, press the 'START' key and open appropriate hand manifold valve depending on whether you are charging with the engine running or engine stationary (if the A/C system is **OFF** or **ON**).

CHARGING WITH A/C SYSTEM OFF

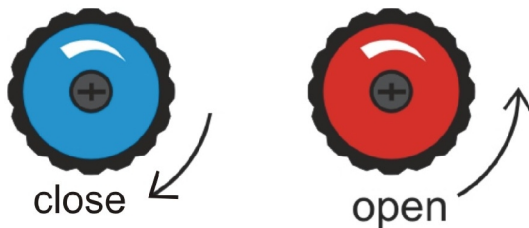

CHARGING WITH A/C SYSTEM ON

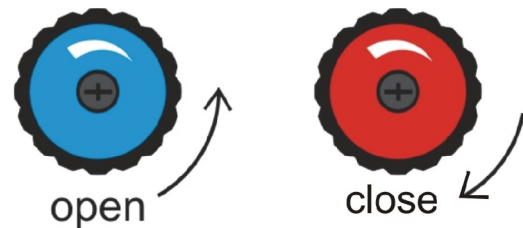

Once the present refrigerant weight has been charged, the charge function will automatically stop and the display will indicate 'DONE'. The operator can return the machine to its initial state by pressing 'STOP' key on the console. After completion of refrigerant charge, the unit will automatically print the report of the amount of refrigerant charged into the A/C system.

9.4.1. Conditions that will stop refrigerant charging

- If there is little or no refrigerant in cylinder (12). The operator will not be able to select the desired amount of refrigerant required.
- If the cylinder (12) valve is closed.
- If the hand manifold valve (4) is closed.
- If the A/C system service port Schrader valve is not depressed

10. Automatic Cycle Procedure

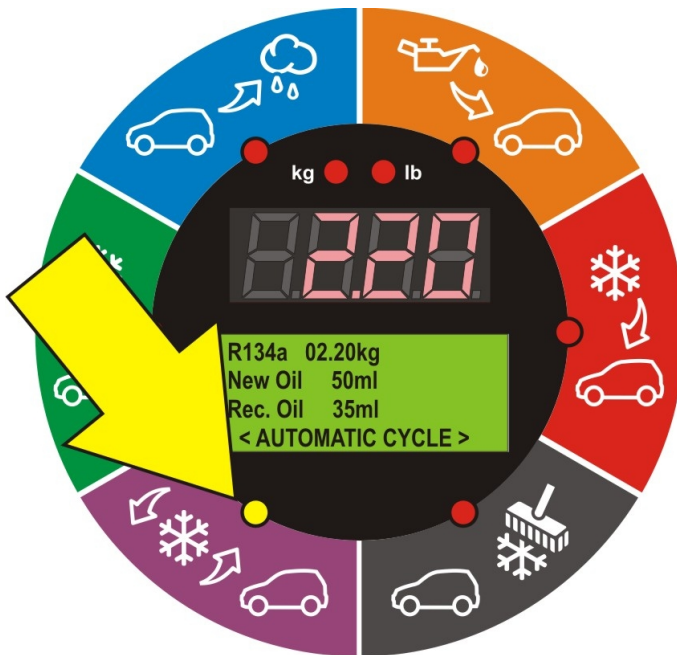

In the Automatic cycle mode, all the operations (Refrigerant Recovering and Recycling, Recovered Oil Drain, Evacuation, New Oil and/or UV Dye Injection and Refrigerant Charging) are performed automatically one after the other in **ONE CYCLE**.

Quantity of the refrigerant recovered, recovered oil, vacuum time, oil injected and refrigerant charged into the A/C system are printed at the end of each single operation.

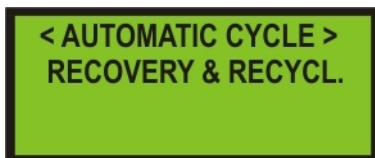

To initiate the Automatic cycle mode, press the 'DOWN' key once, followed by 'START' on the console.

Press "START" button to confirm the **Recovery function**.

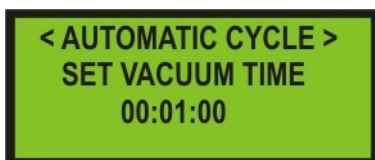

By pressing the 'UP' key to increase or 'DOWN' key to decrease select the desired **Evacuation** Time Duration.

Once the desired time has been selected, press 'START' key.

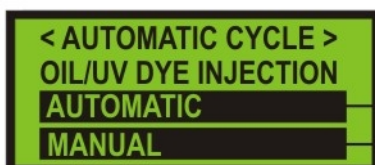

Oil/UV Dye injection selection. The operator can choose between:

- **AUTOMATIC** selection. The unit determines the quantity of oil extracted during the recovery process and will inject the same quantity back in the a/c system. Only desired quantity of UV dye can be selected.

- **MANUAL** selection. With 'UP' key (to increase) or "DOWN" key (to decrease) select the amount of refrigerant oil and/or UV dye to be injected into the a/c system (above the amount of extracted oil). Press ">" key to change UV Dye selection.

Once the desired amount has been selected, press the 'START' key.

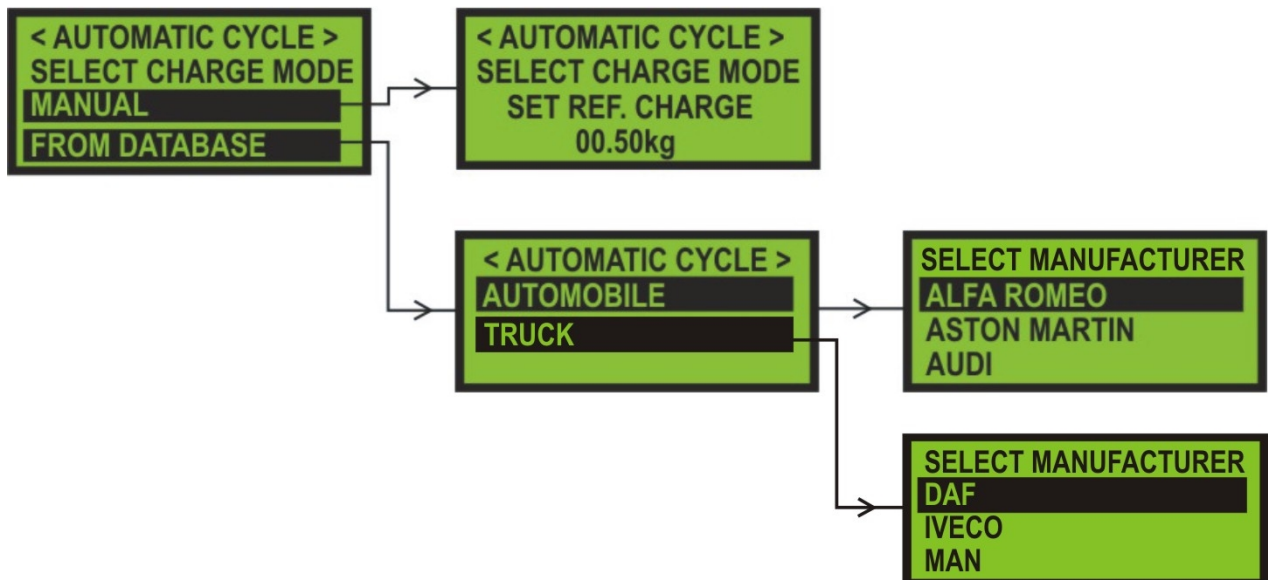

Refrigerant Charge selection. The operator can choose between:

- **MANUAL** selection. Set the amount of refrigerant to be charged into the a/c system (with '**UP**' key to increase or '**DOWN**' key to decrease the quantity. The smallest increment of refrigerant charge weight is 0.01 kg (if the units of weight are to lb the smallest increment of refrigerant charge weight is 0.02lb). Holding the '**UP**' or '**DOWN**' keys for longer than two second will cause the increments of weight change to increase or decrease rapidly.

- **FROM DATABASE.** Select the vehicle and model from unit database.



Important: Once the refrigerant charge weight has been set, open both hand manifold valves and press the '**START**' key. **A/C system must be OFF.**

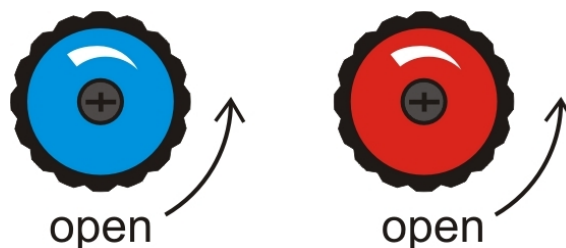

The unit will perform all tasks in one automatic cycle and will print reports at the end of each single operation.

10.1. Conditions that will prevent automatic cycle procedure

a) If the vacuum test failed.

If the vacuum of min -0.85 Bar is not reached after first 90sec of evacuation process, the unit will beep and display TEST FOR LEAK, indicating for possible leak in the a/c system or bad connection of the service hoses.

After the evacuation process is completed, the unit is testing of any possible vacuum leak that may exist in the air-conditioning system. After 180 sec, if the a/c system is NOT holding the vacuum the display will show FAILED and the unit will not charge the a/c system.

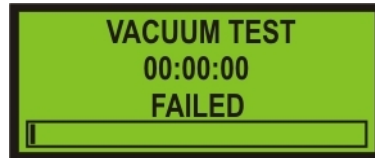

b) If there is little or no refrigerant in cylinder (12). Display shows "**ADD REF**". The operator must add refrigerant into unit cylinder (12).

c) If the recovered oil vessel (9) is full, and display will show "**OIL FULL**". The operator must empty the recovered oil vessel. Dispose of used oil properly.

Note: If the recovered oil vessel becomes full during the oil drain, the process will be stopped. Display will show "OIL FULL". Operator must empty the vessel and press "STOP". The automatic cycle will then continue.

d) If new oil vessel (10) is empty display will show "**ADD OIL**". The operator must fill the oil vessel.

Note: During the process of oil injection, if there is insufficient oil in the new oil vessel (10), the display will show "ADD OIL". The operator must add the oil in the vessel and press "STOP". The automatic cycle will then continue.

e) If the refrigerant cylinder (12) is full. To protect the storage cylinder from being overfilled, the unit will not allow the operator to recover refrigerant once it has reached 80% of its capacity.

f) If the hand manifold valve (4) console are closed.

g) If the A/C system service port Schrader valve is not depressed

h) High Pressure. If the operating pressure of the unit exceeds 25 bar (340 psi), the unit will stop and display '**H- PRES**'. The following can cause the above:

- Cylinder (12) valves not open.
- Restricted cylinder hose (16). Check the ball valves.
- Excessive high ambient temperatures.
- Excessive air in refrigerant cylinder.
- Faulty pressure control
- Recovery pump thermo control faulty.

In all the above circumstances, press the '**STOP**' key to return to the machines initial mode. If all the above conditions are OK, contact your local distributor or manufacturer for further advice.

11. Flushing the A/C system with refrigerant

The purpose of the refrigerant flushing mode is to clean (flush) A/C system with high flow rate liquid refrigerant, against the normal flow direction.



Important: To start flushing mode cylinder (12) must contain minimum 5kg of refrigerant.

Connecting the unit on the A/C system for flushing

Components of the a/c system such as the compressor, expansion valve and filter dryer should be exchanged with special adapters with large flow.

A/C Refrigerant Cycle

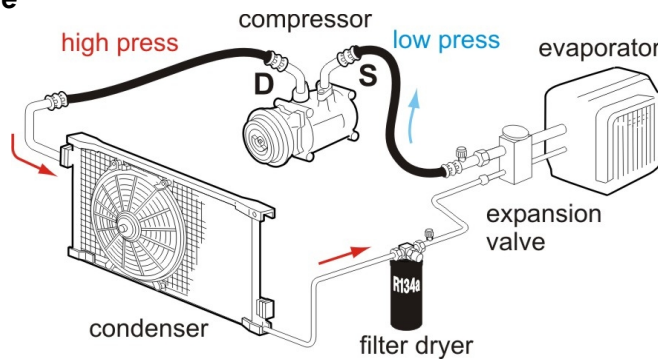

Step 1: Removing the components

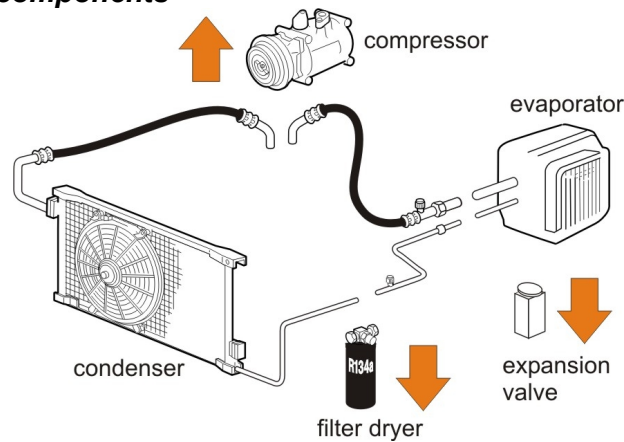

Step 2: Exchanging the components with high flow adapters

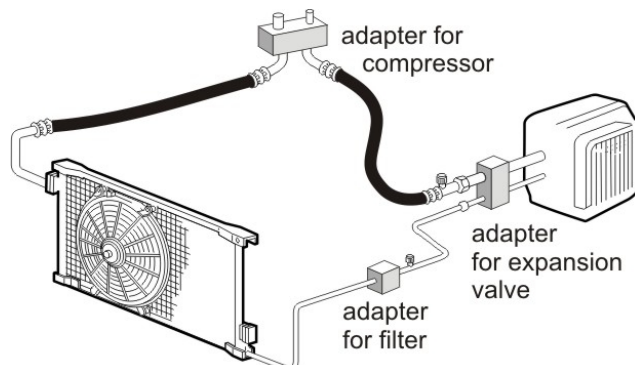

Make sure that service hoses (5) are empty (recover refrigerant if not).

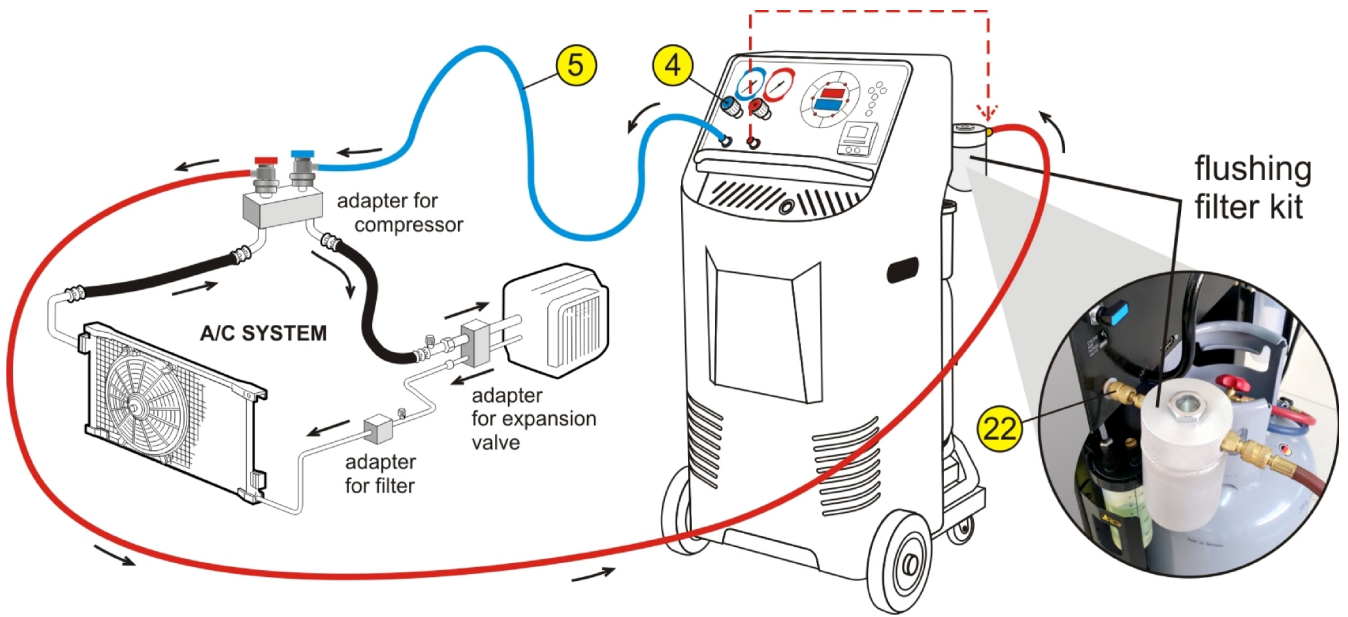

Connect flushing filter kit on the flushing port (22), located on the rear upper left side of machine. Close red hand valve (4) and disconnect red (discharge) service hose from control panel (place protective plastic cap on the port below) and connect it on the flush filter kit. Open blue hand valve (4).

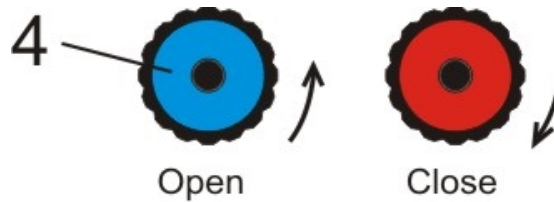

After the connecting has been made, follow next procedure for flushing the A/C system. Select the Flushing mode by pressing the 'UP' or 'DOWN' keys, followed by the 'START' key.

Now the display will shows the following:

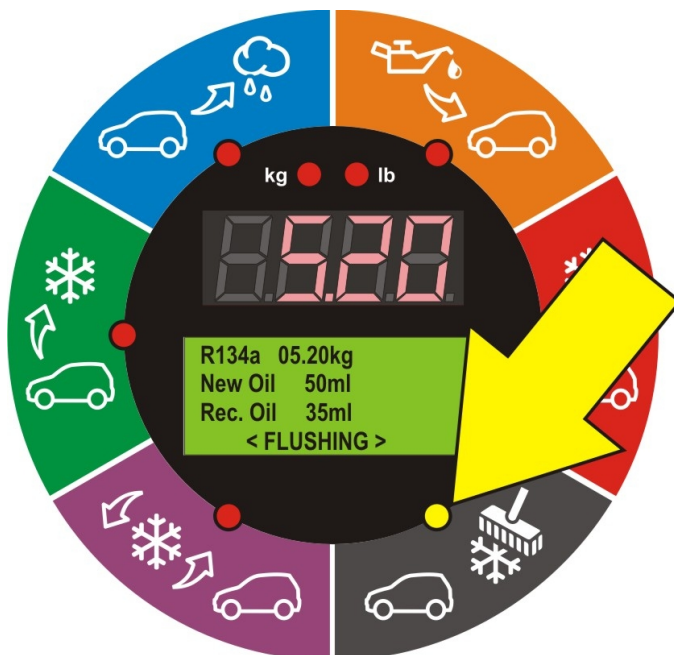

Select the desired flushing time duration (from 30min up to 3 hours) by pressing the 'UP' key to increase or 'DOWN' key to decrease time duration. Once the desired time has been selected, press the 'START' key and the function will commence.



First, the A/C system will be evacuated for a five minutes. After evacuation, the A/C system is flushed with liquid refrigerant under the pressure upon the selected time of flushing. The refrigerant which is used to flush the A/C system is purified and return at the cylinder to be used again. At the end the unit will recover the refrigerant from the A/C system.

After completion of refrigerant charge, the unit will automatically print the report of flushing time duration and amount of oil which has been recovered from the A/C system.

In general the flushing kit does not require any maintenance. However, we recommend the exchange of the filter before the flushing of the a/c system.

When changing the filter observe the manufacturer's instructions.



Flush kit (complete)



Flush filter

11. Cylinder Air Purge

Once a week before using the machine check if there is non-condensable (air) build up in the refrigerant cylinder.

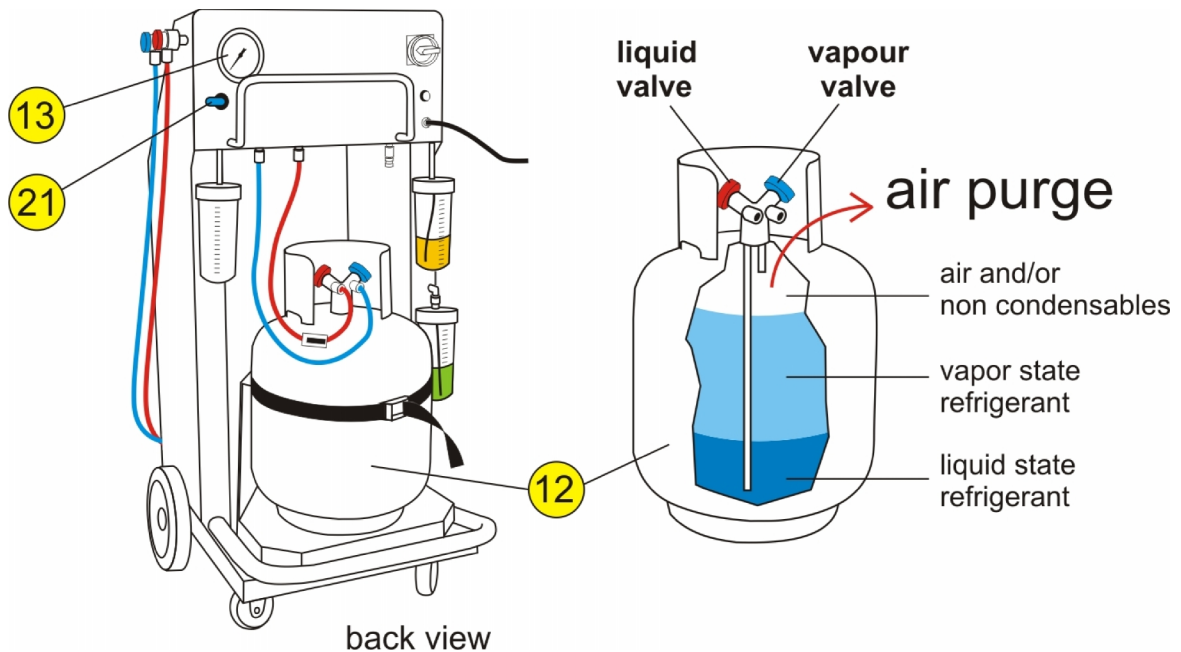

First, measure the ambient temperature. Then read the cylinder pressure on rear gauge (13) and compare it with the temperature pressure chart, affixed to the machine.

If the cylinder pressure is higher than the pressure/temperature chart, there are non-condensable gases (air) in the cylinder (12).

Slightly OPEN ball valve (21) to purge the non-condensable gases (air) from the cylinder (12) and bring back the pressure to the recommended chart values.



Important: After recovery process it is normal that cylinder pressure is higher than the pressure/temperature chart shows. Always read the cylinder pressure gauge (13) first thing in the morning before operating the machine.

Example: Ambient temp. 20 °C, the cylinder pressure should be 4.7 bar.

Ambient temperature (C°)	Air purge gauge readings	
	bar	PSI
8	2.9	42
12	3.4	49
18	4.3	63
20	4.7	68
22	5.1	73
24	5.4	79
26	5.8	84
28	6.2	90
30	6.7	96
34	7.6	110
38	8.6	124
42	9.7	141
46	10.9	157
50	12.1	175

12. Service Procedure

Every 100 Working Hours /Once a Year Service.

The service alarm will alert the operator for maintenance and filter replacement.



The following table describes the service intervals of the unit.

Interval	Component	Procedure
Every 100 Hr / Once a year	Main Filter Dryer	Replace
Every 100 Hr / Once a year	Primary Recovery Line Filter	Replace
Every 100 Hr / Once a year	Vacuum Pump Oil - 330ml	Drain and refill
Every 100 Hr / Once a year	Service hose rubber gaskets	Check / Replace
Every 100 Hr / Once a year	Gauges	Test calibration
Every 100 Hr / Once a year	Weight Platform	Test calibration



Service Kit 100Hr

- Vacuum pump Oil ,
- Recovery Line Filter
- Main Filter Dryer
- Service Hoses Rubber Gaskets

Every 300 Working Hours Service.

The unit requires 100 hour service plus replacing of oil separator, primary charging filter and recovery pump (compressor) oil.

Interval	Component	Procedure
300 Hours	Oil Separator	Replace
300 Hours	Primary Charging Line Filter	Replace
300 Hours	Recovery Pump Oil - 500ml	Drain and refill
300 Hours	Main Filter Dryer	Replace
300 Hours	Primary Recovery Line Filter	Replace
300 Hours	Vacuum Pump Oil - 330ml	Drain and refill
300 Hours	Service hose rubber gaskets	Check / Replace
300 Hours	Gauges	Test calibration
300 Hours	Weight Platform	Test calibration



Service Kit 300Hr

- Vacuum pump Oil ,
- Recovery Line Filter
- Main Filter Dryer
- Charge Line Primary filter
- Compressor oil
- Oil Separator
- Service Hoses Rubber Gaskets

Manufacturer recommends a record of all services on the machine to be kept.



Important: Always wear appropriate protect clothing and safety glasses when servicing the machine.

14. Unit Settings

Press and hold depressed the "STOP" button and switch ON the unit (on the main power switch at back). After few seconds, the unit will enter in setup mode and the display will show the list of available settings:



TARE – 14.1 Setup Tare (00.00kg calibration)

SPAN – 14.2 Setup Span (weight calibration)

CYLINDER SETTINGS - 14.3. Set up of max allowable refrigerant weight in cylinder, oil in recovered oil vessel and minimum allowable refrigerant in the cylinder.

WORKING HOURS RESET - 14.4. To reset the filter replacement interval on new 99 working hours

RELAYS TESTING – 14.5. Use this mode to check the wiring, relays, solenoid valves, vacuum pump and recovery pump for electrical continuity.

PRE-CHARGE - 14.6. Set the pre-charge value

REFRIGERANT MANAGEMENT - 14.7. The operator can read total recovered weight, total charge weight and total refrigerant transfer.

LANGUAGE - 14.8. Set the Language

TIME & DATE - 14.9. Setup time and date

ADVANCED SETTINGS - 13.10. Manufacturer area only

14.1. Setup Tare (00.00kg calibration)

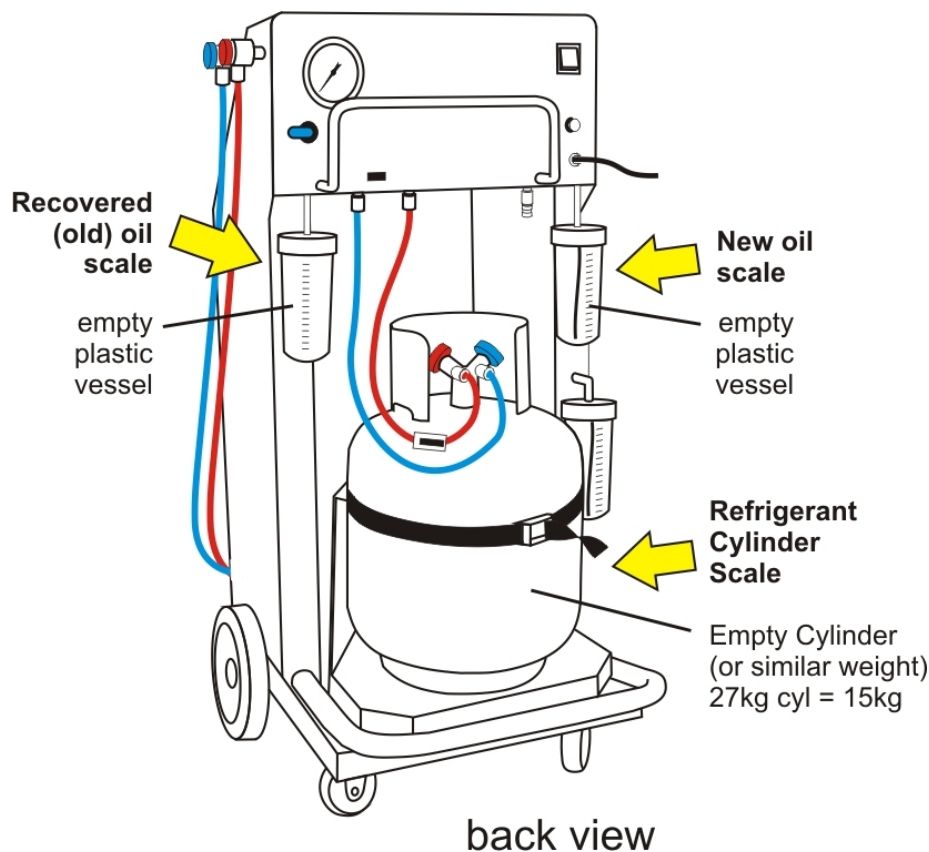

Select TARE and press "START" key. The display will show the following:



REFRIGERANT SCALE

(Calibrating the weight display to read 00.00kg with an empty cylinder on the unit platform)

Place empty cylinder or similar weigh (as unit empty cylinder ~15kg) on the cylinder platform. Connect the cylinder hoses to the cylinder. Checks that the cylinder and platform are free (no touching the body of the machine) and the strap is properly secured.

When ready, press "START" key to confirm. The unit display should show app. 0.00 kg.

RECOVERED OIL SCALE

(Calibrating the weight display to read 00.00ml when recovered oil vessel is empty)

Place empty plastic vessel on recovered oil load cell. Checks that the plastic body and load cell are free (no touching the body of the machine).

When ready, press "START" key to confirm. The unit display should show app. 00.00 ml.

NEW OIL SCALE

(Calibrating the weight display to read 00.00ml when new oil vessel is empty)

Place empty plastic vessel on new oil load cell. Checks that the plastic body and load cell are free (no touching the body of the machine).

When ready, press "START" key to confirm. The unit display should show app. 00.00 ml.

14.2. Setup Span (weight calibration)

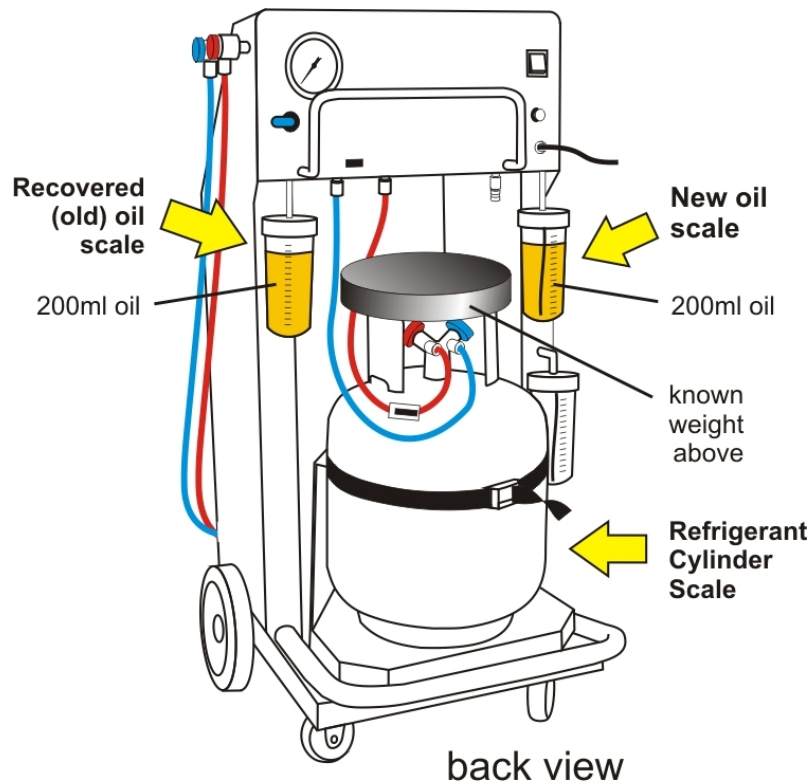

Select SPAN in main <SETTINGS> many and press "START" key. The display will show the following:



REFRIGERANT SCALE - (Calibrating the refrigerant cylinder electronic scale)

Place known weight (etalon) on top of empty cylinder. Known weigh should be minimum 10kg.

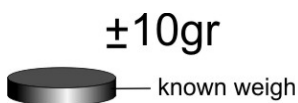

Important: Operator should know the right amount (+-10gr) of the weigh he is using.

Make sure it is placed centrally on the cylinder and platform. Use "UP" or "DOWN" key to move span until display shows the value of additional etalon weight added. Press "START" key to exit and save.

RECOVERED. OIL SCALE - (Calibrating the recovered oil vessel (9) electronic scale)

Add 200ml of oil into the recovered oil vessel. Use "UP" or "DOWN" key to set the correct weight of 200ml (the display should indicate the weight of 0.200 ml). Press "START" key to lock in correct weight and exit.

NEW OIL SCALE - (Calibrating the new oil vessel (10) electronic scale)

Add 200ml of oil into the new oil vessel. Use "UP" or "DOWN" key to set the correct weight of 200ml (the display should indicate the weight of 0.200 ml). Press "START" key to lock in correct weight and exit.

14.3. Cylinder Settings

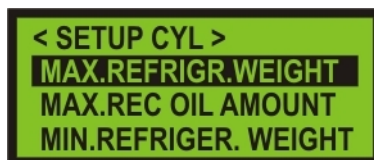

MAX. REFRIGERANT WEIGHT - Set up of max allowable refrigerant weight in cylinder (12)

Use "UP" or "DOWN" keys to set the cylinder weight to 80% of its capacity (20kg max. for 27kg cylinder). Press "START" to save the above settings.

MAX. RECOVERED OIL AMOUNT - Set up of maximum recovered oil level in vessel (9)

Use "UP" or "DOWN" keys to set maximum recovered oil level in vessel (9). Set to 175ml. Press "START" to save the above settings.

MINIMUM REFRIGERANT. WEIGHT- Set up of minimum refrigerant weight into cylinder (12)

Use "UP" or "DOWN" keys to set maximum refrigerant weight into cylinder (12). Set minimum weight to 1.5kg. Press "START" to save the above settings.

14.4. Working Hours Reset

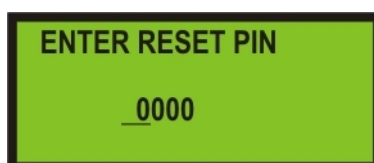

After the system has been completely serviced in according to manufacturer's specifications reset the filter replacement interval on new 99 working hours. Enter PIN code (4 numbers) and press "START".

14.5. Relays testing

Use this mode to check the wiring, relays, solenoid valves, vacuum pump and recovery pump for electrical continuity.

Select RELAYS TESTING in main <SETTINGS> many and press "START" key. The display will show the following. By pressing "UP" and "DOWN" key to change the relay, with "START" make the relay ON ("STOP" for OFF).

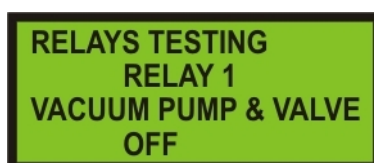

NOTE: Do not run relay number 2 (which controls recovery pump) for more than few seconds.

14.6. Pre-charge (Set the pre-charge value)

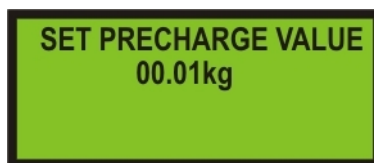

Set the pre-charge value in order to compensate refrigerant that during the charging process stays trapped into the service hoses. Minimum value is 00.01kg.

Recommended pre-charge value for 3m hoses is 00.06kg.
Use "UP" or "DOWN" keys to set desired pre-charge value. Press "START" to save the settings.

14.7. Refrigerant Management



The operator can read total recovered weight, total charge weight and total refrigerant transfer.

14.8. Set the Language



Use "UP" or "DOWN" keys to set language. Press "START" to save the settings.



Important: In a case of choosing unknown language or letters, while the unit is still in SET UP mode, press & hold "<" (arrow) for a few seconds and the language will automatically change in English.

14.9. Time & Date - Setup time and date



14.10. Advanced Settings - Manufacturer area only

14.11. Kg or Lb - Set Metric or Imperial system



While machine in “stand by” press and keep depressed “STOP” button for few seconds until numerical display show SET and LED indicator start to flash.

With “START” key select KG (for metric) or LB (for imperial). Press “STOP” to confirm the selection.

Notes:

EC Declaration of Conformity

The company: Ariazone International Europe
15-ti Korpus bb.,
6000 Ohrid,
MACEDONIA

Hereby declares that the product:

Ariazone 5001 FAHD/Flush - Automotive A/C Service Station

Meets all requirements of European Directives:
2006/95/EC (ex 73/23/EEC) Low Voltage Directive
2004/108/EC Electromagnetic Compatibility
98/37/EC Machine Directive

and subsequent amendments entered in force to the date of declaration.

The following standards and technical specifications, conforming to EEC Harmonized Regulations were applied:

EN 61010-1:2001 with cross references: EN 60227, EN 60245, EN 60309:2003;
EN 60799, EN 60804, EN 60825-1

EN 55014-1; EN ISO 12100-1; EN ISO 12100-2;
EN ISO 12100-1:2003; EN ISO 12100-2:2003

The producer also declares that equipment confirms Directives and Standards when used according to manufacturer specifications.

Date and place of issuing:

Ohrid, _____

Serial No: _____

ariazone

Ariazone International
Melbourne, Australia
www.ariazone.com

Ariazone International Europe
Ohrid, Macedonia
www.ariazone.com.mk

Made in Macedonia