Benchtop Stability Chamber Temperature And Humidity
Horizontal
(HY-2408)



INTRODUCTION

The HannYA climatic chamber is a testing machine that is designed to test the material characteristics of various types of wires, skins, plastics, rubber, and cloth. It is equipped with a special ventilation regulator that is capable of maintaining a fresh air supply while heating the chamber.

The machine is designed with a sophisticated air-displacement adjustment device, which allows for precise control of the internal air flow. It also features a digital voltage meter, current meter, watt-hours, and timer, which can be used to measure the air replacement rate.

To ensure internal temperature uniformity and stability, the HannYA climatic chamber utilizes a horizontal circulatory air supply system, along with airflow regulators on both sides. This design ensures that the internal temperature of the chamber remains consistent, regardless of the location of the test material.

Overall, the HannYa climatic chamber is a highly advanced testing machine that is ideal for testing the material characteristics of a wide range of materials. Its advanced features and precise control make it an essential tool for researchers, manufacturers, and quality control professionals in a variety of industries.



SPECIFICATIONS

Model	HY-280	HY-2150	HY-2225	HY-2408	HY-2800
Inner Size WxHxD(cm)	40x50x40	50x60x50	50x75x60	60x85x80	100x100 x 80
Outside Size WxHxD(cm)	93x155x95	100x148x106	117x166x91	140x176x101	170x186 x 111
Volume (V)	80 L	150L	225L	408L	800L
Temp and Hum Range	A: -20°C~150°C B: -40°C~150°C C: -60°C~150°C D: -70°C~150°C RH20%-98%				
Function	Fluctuation	±0.5°C ±2.5%RH			
	Deviation	±0.5°C±2°C ±3%RH(>75%RH); ±5%RH(≤75%RH)			
	Controller Analytical Accuracy	±0.3°C ±2.5%RH			
Wind Cycling Way	Centrifugal fan-broadband type forced air circulation				
Refrigeration Way	Single stage compression refrigeration				
Refrigerator	French Tecumseh				
Refrigerants	R404A USA DuPont environmental protection refrigerant(R23+R404)				
Condensing Way	Air-cooled or water-cooled				
Heater	Nickel chrome heating wire heater				
Humidifier	Semi-closed steam and wet				
Water Supplying Way	Automatic cycling water supply				

ENERGY CONSERVATION

Guarantee the sample with no condensation

The chamber has a function to prevent condensation when the temperature and humidity rise up have some error, to prevent damage to the sample.

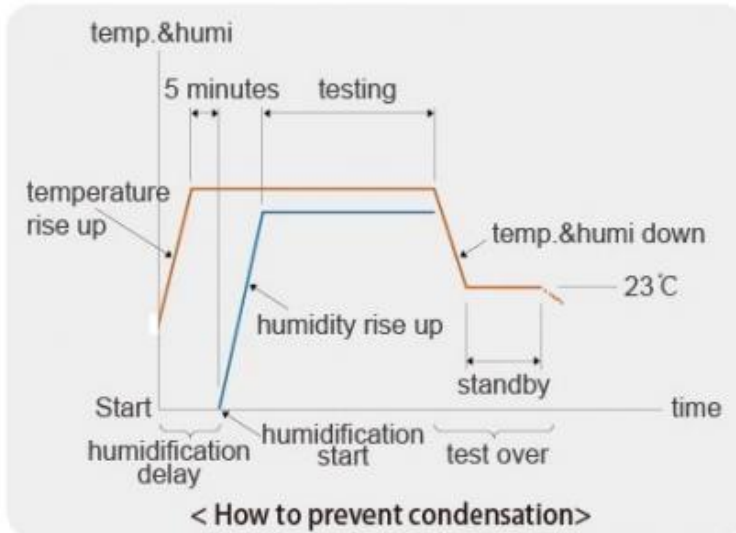

 	<p>Cut off overheating, overcurrent</p> <p>By cutting off the overheating and over-current to protect the safety of the machine and the user.</p>	 	<p>Controller</p> <p>We used the touch screen programmable controller, and the controller can be customized according to customer needs.</p>
 	<p>Service port</p> <p>Communication and operation, alarm, time signal are provided by relay contact.</p>	 	<p>Low power consumption</p> <p>Install the power outlet on the side of the chamber for customer power test.</p>

Energy Conservation

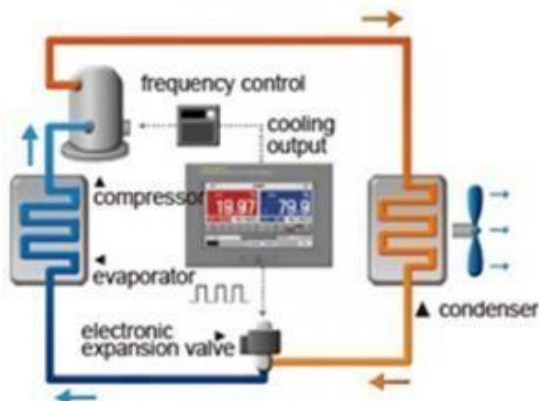

Through the controller output signal, control the frequency converter and electronic expansion valve, accurately adjust the refrigerant flow, in order to achieve energy saving effect, and the cooling system will more stable. (Frequency control is optional)

Temperature Humidity Range Of Control

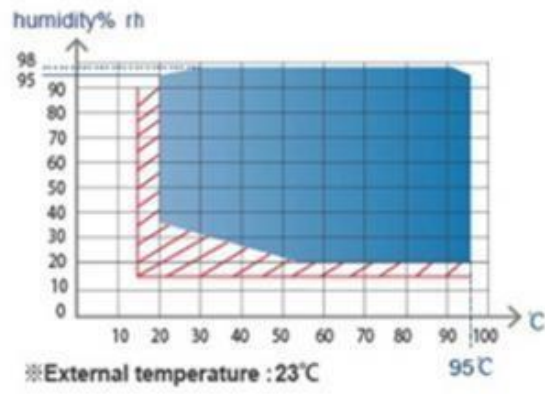

Can support the humidity from 20% to 98% in the temperature range of +10 to 85, to maximize the simulation of the atmospheric environment, can design a variety of tests.
(Temperature & Humidity Stability is $\pm 0.3\text{ }^{\circ}\text{C}/\pm 0.3\%$, With Uniformity $\pm 1\text{ }^{\circ}\text{C}/\pm 5\%$)