

Pipeline Metal Separator

Digital Model EJH-23LP

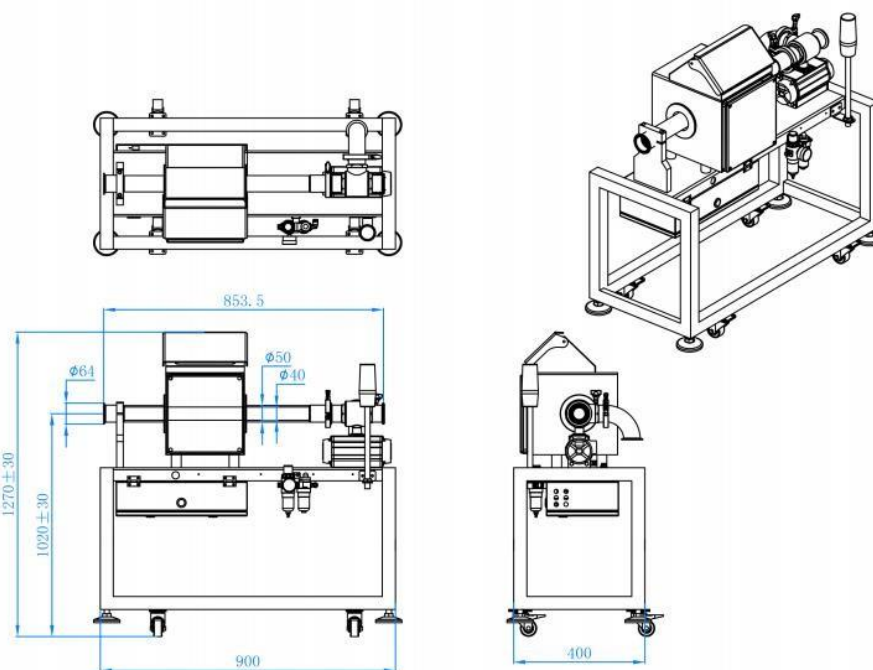

Applicable:

It is used to detect various liquids such as sugar water, oil, sauce, fruit juice and other raw materials mixed liquid in the production and processing of metal impurities.

Features:

1. It adopts dual-channel signal detection circuit merging technology, which has high sensitivity and high anti-interference ability.
2. Adopted full digital DSP programming design, LCD digital screen operation, English operation menu.
3. The signal processing is automatically calculated by the digital chip, which can quickly and automatically learn to obtain the best detection phase, and can store and memorize 99 products, which is stable and reliable.
4. The function of automatic learning of product parameters and restrict product effect, such as sugar, salt mixtures, high humidity containing foods, such as juice and sauce etc., will produce metal signals to the machine. This effect will affect the detection effect. This function can automatically reduce the product Effect to achieve the best results.

Technical specifications:

Machine Model	EJH-23LP-50	EJH-23LP-65	EJH-23LP-80	EJH-23LP-100
Outer pipe(diameter)	64mm	77mm	91mm	119mm
Inner pipe(diameter)	47	59	72	98
Sensitivity(unloaded product)	FE:0.8	FE:1.0	FE:1.2	FE:1.5
	CU:1.2	CU:1.5	CU:2.0	CU:2.5
	SUS:1.5	SUS:2.0	SUS:2.5	SUS:3.0
Tip	above data is empty-loaded machine basic sensitivity. The real sensitivity will be lower on condition of different products being tested.			
Operation Method	Digital LCD display screen			
Automatic Setting	automatic setting function, 99 kinds of products storage			
Flow Rate	15-40m/min			
Operating Temperature	-20°~80℃			
Foot cup with Casters	304 stainless steel thickened with fixed hole foot cup 3 inch universal caster with brake			
Reject device	Automatic reject with sound indicator light			
Voltage	220V 50~60Hz			
Pipe Material	Teflon (food contact grade, sanitary grade, temperature resistant type)			
Shunt Valve	YUANJI three-way pneumatic valve Air pressure 5~6 kg Valve body material 304 stainless steel			