

## HY-SA-980 Heavy Bear for Industrial

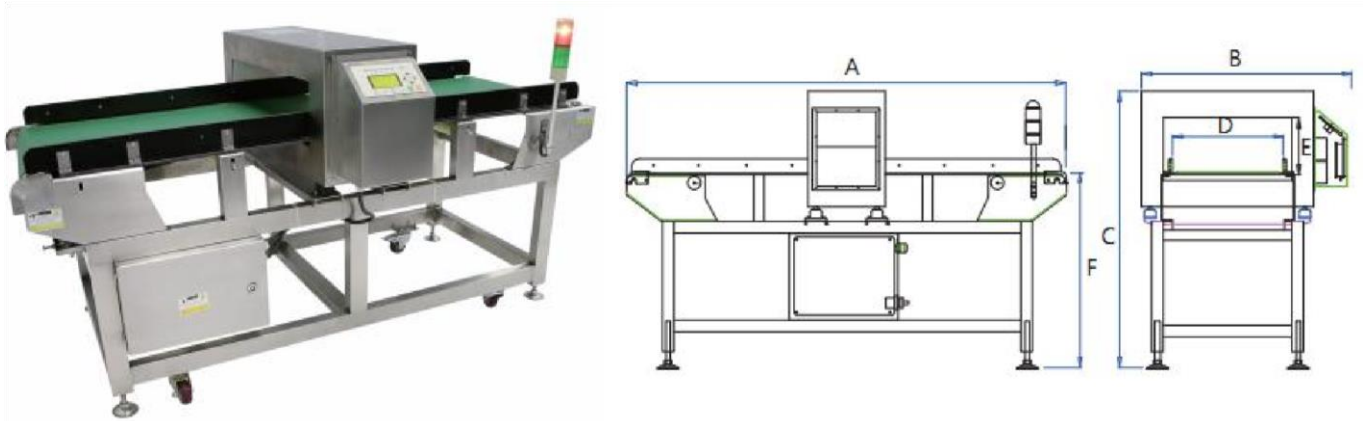

### Product features and advantages:

1: Advanced technology: the introduction of imported multi-detection technology, phase and comprehensive, product and automatic balance correction technology, the detection sensitivity and stability have been improved, the detection range is wider, especially for salt, high moisture content is difficult to detect The product has 2-3 times better detection sensitivity than similar products.

2: The core circuit adopts a single-chip high-performance FPGA hardware solution, using imported high-quality electronic components; [mainly selected by the United States Micro-chip, Analog Device, National Semiconductor, Wimma, Japan Hitachi, NEC, Sanyo and other companies to produce integrated circuits, capacitors, etc. Electronic components] After advanced processing technology and standardized inspection process, the product has high sensitivity and stable performance.

3: Mandatory function, user-friendly function: automatic learning function, quickly learn product features, complete automatic setting, as long as the test product passes the detection area once, the device automatically adjusts to the best detection effect, and truly realizes "fool-like" operating.

4: The whole machine has good protection effect, the fully sealed design and low power design and the structural structure of the equipment ensure the protection effect, and truly achieve the P67 protection level. The imported waterproof motor and the original Japanese waterproof bearing ensure the quality of the whole machine. And environmental adaptability. 5: The introduction of the US technical team, the production base is located in the international manufacturing city of Dongguan, Guangdong, the industrial base is strong, the R&D center and the professional probe company of the United States cooperate with the technical talents, focusing on the research and development and production of high-sugar testing equipment; And CNC machining technology, high processing accuracy.

6: High cost performance, the performance of imported quality products, the price is about 30% of imported products. The product is durable.

### **Application:**

Food, pharmaceuticals, chemicals, rubber and plastics, ice products, toys, eyewear, shoes, leather, knitting, printing, etc. The metal impurities in the production process or raw materials, such as iron and non-magnetic metal materials (gold) Silver, steel, aluminum, stainless steel and other non-ferrous metals can be detected), improve product safety factor and reduce hazards.

### Parameter:

HY-SA-980 Heavy bear series		5015	5020	5025	5030	6020	6025	6030	6035
50 Through width (MM)		500	500	500	500	600	600	600	600
Passing height (MM)		150	200	250	300	200	250	300	350
Belt width (MM)		470	470	470	470	570	570	570	570
standard Detection Sensitivity	FE(ΦMM)	1.0	1.2	1.5	1.6	1.2	1.5	1.6	1.8
	NON-FE(Φ	1.5	1.8	2.0	2.3	1.8	2.0	2.3	2.5
	SUS304(Φ MM)	2.0	2.3	2.5	3.0	2.3	2.5	3.0	3.0
Conveyor length (MM)		1700	1700	1700	1700	1800	1800	1800	1800
Belt height from ground		650±150 customizable							
Protection level		IP67							
Number of memory		100 kinds							
Display method		LED LCD (or touch screen customization)							
Operation method		Touch button input (touch optional)							
Conveyor belt material		Food grade PVC belt (PU belt)							
Alarm mode		Alarm stop, buzzer alarm or reject mechanism optional							
Belt speed		28M\MIN constant (can be customized frequency control)							
Machine material		Carbon steel paint or stainless steel 304, fit for HACCP.GMP.CAS							
Machine weight		About 320KG							
motor		Taiwan high-power motor can transport weight 1-15KG							
power supply		AC220V±10% 50-60HZ (can be customized AC110V or 380V) other optional							
Use environment		Temperature: -18 ~ 50 ° C, relative temperature: 30 ~ 90 ° C							
<p>Remark: 01 probe detection window, the size of the whole machine can be customized according to customer needs. The higher the height of the detection window, the lower the detection sensitivity, and the wider the detection window, the lower the detection sensitivity.</p> <p>02 Detection sensitivity is the detection sensitivity obtained by placing the test card in the center of the conveyor belt through the detection channel. The actual detection sensitivity will vary depending on the product being tested or the conditions of use.</p>									