

Table of Contents

Preface	1
1. Notes on Safety	3
1.1. Notes on Safety	3
2 Specifications	7
2.1 Common specifications for SB150 series	7
2.2 Product series	8
3 Installation and wiring	9
3.1 Installation	9
3.2 Removal and installation of parts	10
3.3 Peripherals and options	11
3.4 Wiring	13
3.5 Methods of suppressing electromagnetic interference	17
4 Operation and commissioning	20
4.1 Operation and display	20
4.3 Quick and optimize commissioning	23
5 Parameter table	25
6 Parameter Description	37
6.1 F0 Basic Parameters	37
6.2 F1: Acceleration/Deceleration, Startup, Shutdown and Jog Parameters	39
6.3 F2 V/F Control Parameters	42
6.4 F3 Motor parameters	44
6.5 F4 Digital input terminals and multistep speed	45
6.6 F5 Digital output and relay outputs	49
6.7 F6 Analog and pulse frequency terminals	51
6.8 F7 Process PID parameters	54
6.9 F9 Wobble frequency	57
6.10 Fb Protection functions and advanced settings	60
6.11 FC: Keypad operation and display settings	63
6.12 FF Communication parameters	64
6.13 FP: Fault history	68
6.14 FU: Data monitoring	68
7 Troubleshooting	69
7.1 Faults and remedies	69
7.2 Alarms and remedies	71
7.3 Operation faults and remedies	72
8 Maintenance and After-sale Service	73
8.1 Daily maintenance	73
8.2 Replacement of parts	74
8.3 Storage of the inverter	74
8.4 After-sale service	74

Preface

Thank you for selecting Senlan SB150frequency inverter series. SB150 is a compact inverter adopting the optimized high-performance space vector control VVVF arithmetic and featuring elegant appearance, delicate circuit design, ingenious circuit design, simple and practical functions, and reasonable menu arrangements, which supports numerous advanced functions, e.g. auto torque boost, slip compensation, oscillation suppression, tracking startup, stall prevention, precise deadband compensation, auto voltage stabilization, process identification and auto carrier frequency adjustment. The series are suitable for most industrial control applications.

This manual provides the user with a guide on installation & wiring, parameter setting, daily maintenance, fault diagnosis and troubleshooting. The user is required to peruse the whole content of the manual carefully and be familiarized with the relevant know-how and notes on inverter safety before any attempts of installation, setting, operation and maintenance.

The technical specifications applied to this product or the content of this manual may be subject to any change without prior notifying.

This manual is required to be kept properly until the inverter is out of its service life.

Items to Be Checked on Opening the Packing Case

The user is required to carefully check and confirm the following items on opening the packing case. If you have any problem, don't hesitate to contact us or your supplier for a solution.

What to Confirm	How to Confirm
Is the inverter identical with the product you've ordered?	Check if the nameplate inscriptions on the side of the inverter comply with the requirements in your order
If there is any damages on the product?	Check the overall appearance of the product to see if there are any damages arising from transportation

Inverter Model Description

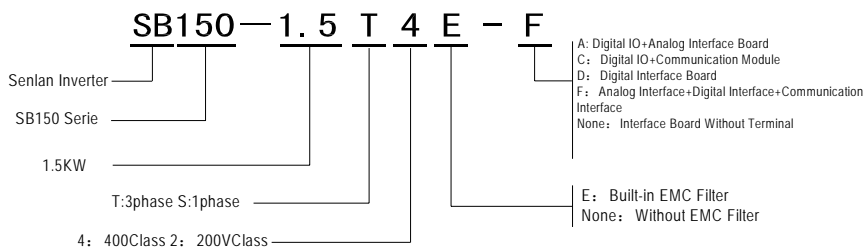

Inverter Nameplate Inscriptions (Instance:SB150-1.5T4E-F)

SENLAN INVERTER		Made In China
Type: SB150-1.5T4E-F	Applicable Standard GB/T12668.2	
Rated Input: 3phase 380V 50/60Hz	Product S/N: 1234567	
Rated Output: 3phase 0~380V 0~650Hz		
Rated Current: 3.7A	Bar Code	
Rated Power: 1.5kW		

 **SLANVERT** Hope Senlan Science and Technology Holding Co., Ltd

Definition of Safety ID Markings

Any safety-specific content of this manual may use the following markings for identification. The user is required to follow the instructions of the content identified with safety markings.

 **CAUTION: Any wrong operation or against the instructions may cause inverter damage or personal injury/fatality.**

 **CAUTION: Any noncompliant operation may cause abnormal system operation which, in serious cases, may induce inverter damage or mechanical damage.**

1. Notes on Safety

1.1. Notes on Safety

(1) Installation

- The inverter must not be installed at places with combustibles or in the vicinity of combustibles; otherwise there may cause fire.
- The inverter must not be installed in an environment exposed to flammable gases; otherwise There may cause explosion.

(2) Wiring

- Confirm that the positive/negative busbar voltage is below 36V; otherwise there may be a risk of electric shock.
- Confirm that no wiring operation is permitted unless the power supply is thoroughly disconnected; otherwise there may be an electric shock hazard.
- Do not try to connect the DC terminals (DC+, DC-) directly with a dynamic braking resistor; otherwise there may be a fire hazard.
- The terminal voltage of the power supply must not exceed the rated voltage; otherwise there may be inverter damage.
- The grounding terminal (PE) of the inverter must be securely connected to earth (resistance to earth $\leq 10\Omega$); otherwise there may be a risk of electric fire.

(3) Check before switching on the power

- Close the cover board of the inverter before turning on the power; otherwise there may be a risk of electric shock or explosion.
- Before trying to run the motor at a frequency over the rated motor frequency, conform that the motor and the mechanical devices can endure such a high speed.

(4) Precautions on power and operation

- Check to see if parameters are set appropriately before commissioning.
 - Do not open the front cover while the input power is switched on, for the high voltage inside may cause electric shock.
 - Do not handle the inverter with wet hands. That may lead to electric shock.
 - “Power-on auto start” is enabled before shipment from the factory. When the terminal control and the run signal are valid, the inverter will start automatically once the power is turned on.
 - Do not control the run and stop of the inverter by switching on and off the input power.
 - Related parameters should be reset after parameter initialization.
 - If the function of restart has been set (such as auto-reset or restart after momentary power failure), do not approach the motor or mechanical load while the inverter is waiting to restart.
-

(5) Precautions on transport and package

- Do not place more inverters than specified in the packaging box.
- Do not put any heavy object on the inverter.
- Do not open the cover board during transport.
- Do not apply any force on the keypad and the cover board while handling the inverter, otherwise there may be a risk of injury to people or damage to equipment.

(6) Disposal

- Dispose the inverter as industrial waste.
- The electrolytic capacitors inside the inverter may explode while burned.
- Plastic components of the inverter will generate toxic gases while burned.

1.2 Other precautions

(1) About motor and mechanical load

- Comparison with commercial power operation

SB150 inverter is a voltage-type PWM motor drive. Its output voltage contains some harmonics. Compared with the commercial power, it creates more loss and noise and leads to higher temperature rise of the motor.

The insulation withstands voltage of the cables and motor should be taken into account when the input voltage is high or the motor cables are long.

- Constant-torque, low-speed operation

When a common motor runs at low speed for a long time, the motor temperature will rise due to the weakening cooling effect. So if a motor is required to operate at low speed and constant torque for a long term, an inverter or the forced air cooling method must be used.

- Running above 50Hz

If you plan to run the motor over 50Hz, be aware that the vibration and noise will increase and make sure that the motor bearings and mechanical devices can withstand such a high speed.

- Lubrication of mechanical devices

While running at low speed for a long period, such mechanical devices as gearbox and gears may be damaged due to worsening lubricating effect. Before you run them, check the lubrication conditions.

- Load of regenerative torque

Regenerative torque often occurs while a load is hoisted, and the inverter often stops due to overvoltage protection. In this case, an appropriate braking unit should be selected and installed.

- Mechanical resonant point

Certain output frequencies of the inverter may be the mechanical resonant points. To avoid these points, place anti-vibration rubber under the base of the motor or setting the jump frequencies.

- Motor insulation check before connected to the inverter

When the motor is used for the first time or reused after it has not been used for a long period, the motor insulation must be inspected to prevent the damage to the inverter caused by the failed insulation of the motor windings. Use a 500V voltage-type megaohm meter to measure the insulation resistance, which should not be less than $5M\Omega$.



DANGER: While performing the insulation test on the motor, be sure to disconnect the motor with the inverter, otherwise the inverter will be damaged.



DANGER: Do not perform the voltage resistance test and insulation test on the control circuit, otherwise the circuit elements will be damaged.

(2) About inverter

- Capacitor or voltage-dependent resistor for improving power factor

As the inverter output is of PWM voltage type, the capacitor or voltage-dependent resistor (for improving the power factor) installed on the output side of the inverter will lead to inverter trip or damage to components. Do not remove the capacitor or the voltage-dependent resistor before using the inverter.

- Frequent start and stop

For applications where frequent start and stop are needed, terminals are recommended for the control of the start/stop of the inverter. Using the switching device (such as contactor) on the inverter input side to start or stop the inverter frequently is prohibited. That may destroy the inverter.

- Using the inverter beyond the rated value

It is not recommended to operate the inverter beyond the range of the allowable input voltage. If the inverter has to be used beyond the range, increase or decrease the voltage via a voltage regulator.

- Lightning protection

With the built-in protection of overvoltage from lightning, the inverter has certain self-protection ability against the lightning strike.

- Leakage protector

The high-speed switching operation during the running of the inverter will generate high-frequency current that sometimes causes the mis-operation of the leakage protection circuit. To address this issue, moderately lower the carrier frequency, shorten the wires or install a leakage protector.

Observe the following points while installing the leakage protector.

1) The leakage protector should be installed on the inverter input side, preferably behind the air switch (non-fuse circuit breaker).

2) The leakage protector should be one that is insensitive to higher harmonics or specially designed for the inverter (sensitivity above 30mA). If a common leakage protector is selected, its sensitivity and action time should be greater than 200mA and 0.2s, respectively.

- Derate of inverter

- a) If the ambient temperature exceeds 40°C , the inverter should be derated by 5% for every 1°C increase, and external forced cooling should be provided.

1 Notes on Safety

- b) If the altitude is above 1000 meters, the inverter should be derated by 1% for every 100m rise
- c) .If the carrier frequency is greater than the factory setting, the inverter should be derated by 5% for every 1 kHz increase.

2 Specifications

2.1 Common specifications for SB150 series

Item		Description
Input	Rated voltage and frequency	3-phase: 220v/380V, 50/60Hz
	Allowable range	Voltage: 320~420V; voltage imbalance <3%; frequency: 47~63 Hz
output	Output voltage	3-phase, 0V~input voltage, with the error less than 5%.
	Output frequency range	V/F control: 0.00~650.00Hz Vector control: 0.00~200.00Hz
performance standard	Overload capacity	150% of rated current for 1 minute
	Frequency resolution	Digital reference: 0.01Hz Analog reference: 0.1% of max. frequency
	Output frequency precision	Analog reference: $\pm 0.2\%$ of max. frequency (25 $\pm 10^{\circ}\text{C}$) Digital reference: 0.01Hz
Control terminal	Communication	Built-in RS485 port, supporting Modbus protocol
	Analog input AI	2 channels AI (also used as digital input), voltage or current type, positive or negative, with drop detection
	Analog output AO	1 channels AO, voltage or current type independent terminal to choose
	Digital input	5 channels of multi-function digital input(two of them are analog inputs), sampling period 1ms
	Digital output	1 channel of NPN multi-function digital output, 1 channels of multi-function relay output
Software function	Motor control mode	Space vector V/F control, with auto torque boost and slip compensation
	Command source	Keypad, terminal and communication. They can be switched over by terminals
	Frequency reference source	Keypad(keys and POT), communication, UP/DOWN value, AI1, AI2 and PFI. Auxiliary frequency reference can be introduced for fine tuning
	V/F curve	Linear curve and two reduced-torque curves, with manual and auto torque boost
	Dynamic braking	Built-in braking unit and external braking resistor
	DC braking	Braking time: 0.0~60.0s Braking current: 0.0~100.0% of rated current
	Accel/decel	Linear or S-curve acceleration/deceleration
	Jog	Jog frequency: 0.10~50.00Hz
	AVR	Keeps the output voltage constant automatically when the voltage of power grid fluctuates
	Auto carrier regulation	Carrier frequency is regulated automatically based on the load characteristic and ambient temperature
	Momentary power failure	Ensures uninterrupted operation by controlling the DC link voltage
	Process PID	process PID adjustor, can do 4 references, can disable terminals, and provide PID revise mode, sleep function (suit for water supply industry)
	Wobble	Ensures even winding of textiles
	Multistep frequency	7 multistep frequencies., selected by digital input terminal.
others	Smooth start, stall prevention, zero-speed delay, oscillation suppression, deadband compensation	
Protection functions		Overcurrent, overvoltage, undervoltage, input/output phase loss, output short-circuit, overheating, motor overload, external fault, analog input

2 Specifications

Item		Description
		disconnection, stall prevention, etc.
Options		Braking resistor, input/output reactor, EMI filter, Profibus-DP module, remote control box, LCD keypad etc.
Ambient	Service site	Altitude less than 1000 meters; indoor; no direct sunlight; free of dust, corrosive gases, inflammable gases, oil mist, water vapor, water drops, salt mist, etc.
	Temperature/humid	-10~+40°C/20~90%RH, no condensation
	Storage temperature	-20~+60°C
	Vibration	Less than 5.9m/s ² (0.6g)
Structure	Protection degree	IP20
	Cooling method	Forced air cooling, with fan control

2.2 Product series

SB150 inverter rated value is as follows:

Model	Rated capacity (kVA)	Rated output current (A)	Applicable motor (kW)
SB150-0.4S2	1.1	3	0.4
SB150-0.75S2	1.7	4.5	0.75
SB150-1.1S2	2.3	6.0	1.1
SB150-0.4T2	1.1	3	0.4
SB150-0.75T2	1.9	5	0.75
SB150-1.5T2	2.8	7.5	1.5
SB150-0.4T4	1.0	1.5	0.4
SB150-0.75T4	1.6	2.5	0.75
SB150-1.5T4	2.4	3.7	1.5

Outline drawings of model type SB150-0.4~SB150-1.5

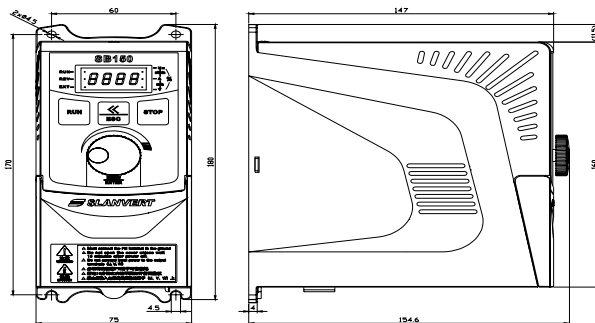

Inverter Outline Drawing

3 Installation and wiring

3.1 Installation



1. The installation of the inverter can be performed only by qualified professionals.
2. Do not install and run the inverter if there is any damage on the inverter or any part is missing, otherwise there may be a risk of fire and injury.
3. Install the inverter on a firm support that can bear its weight, otherwise the inverter may fall and cause damage or injury.
4. Do not apply force on the keypad or cover board while handling the inverter, otherwise the falling of keypad or cover board may cause damage or injury.

In addition to meeting the environment requirements, the inverter should be installed vertically instead of upside down, slantways or horizontally, and fixed to a firm structure with screws. To ensure cooling effect, sufficient space should be maintained around the inverter, as shown below (a partition board should be provided in between if two inverters are installed in a vertical row).

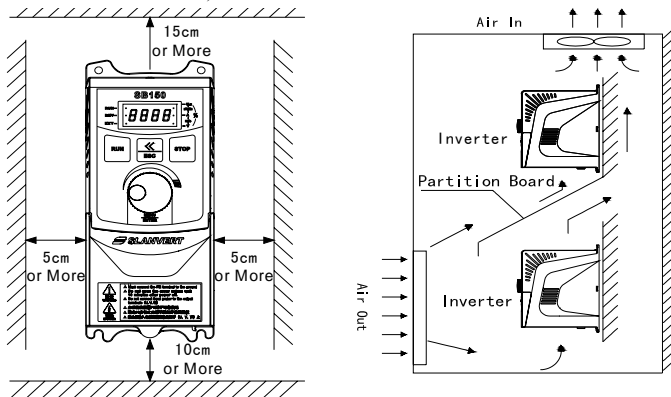

3 Installation and wiring

3.2 Removal and installation of parts

3.2.1 Uninstallation/Installation of Cover and Control Panel

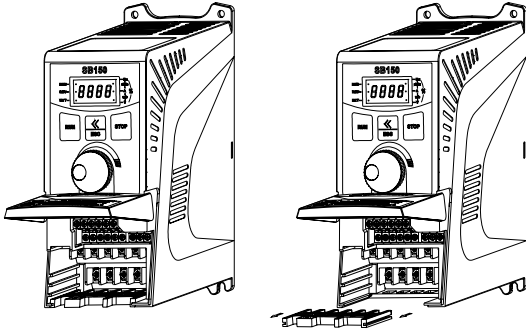

3.2.2 Removal and installation of cooling fan

Cooling fan is installed at the bottom of inverter.

When use the installation hole on the back of inverter, do not need to remove the inverter body from the installation board and then the cooling fan can be changed.

Removal of cooling fan:

1. Follow the direction of Pic (1) and press the right claw shape buckle outside the fan, and meanwhile rotate to the direction of pic (2), the rotation angle should reach 45degree.
2. Please take over the battery socket of cooling fan by hand, and move fan board out.

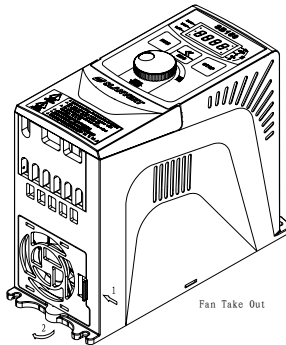

3. Please follow the left pic and remove the cooling fan from the fan board.

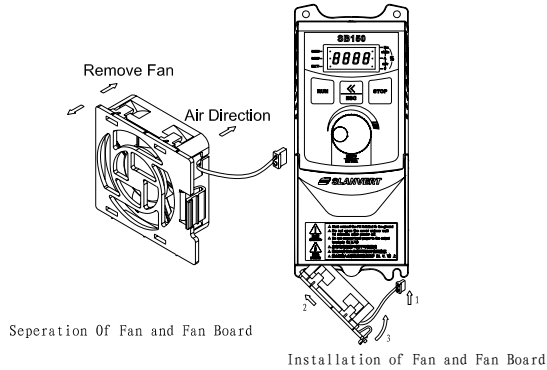

Installation of cooling fan

1. Please refer to the left picture and install the cooling fan into the fan board. Then aim the direction remarks to side of the inverter
2. Please follow the direction (1) of right picture and insert the power connector (pay attention to the positive and negative pole)
3. Please follow the direction (2) of the right picture and insert the fan board into the left side of inverter, and then press the fan board in as the direction of (3). Make sure the claw shape buckle installed correctly.
4. Please check the power line if connected when fan is rotating.

3.3 Peripherals and options

The inverter and its peripherals are connected as follows:

3 Installation and wiring

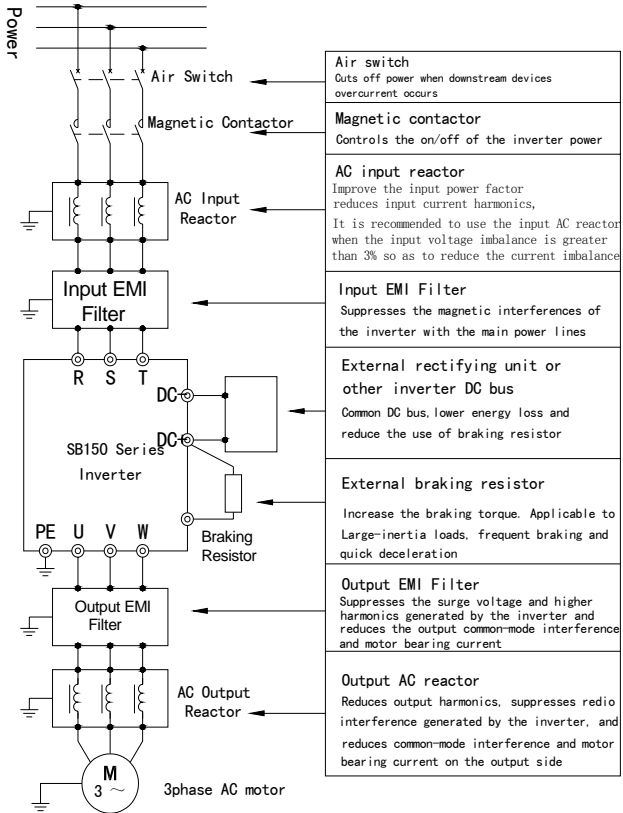

Options provided by our company include braking resistor, input/output reactor, EMI filter, monitoring software SENLANWin, Profibus-DP module, remote control box, etc.

The resistance of the braking resistor should not be less than the recommended value, or the inverter may be damaged. The capacity of the braking resistor must be decided based on the power generation condition(power generation capacity, frequency of power generation, etc.) of the actual load.

Inverter model	Resistance (Ω)	Capacity reference value kW	Inverter model	Resistance (Ω)	Capacity reference value kW
SB150-0.4S2	≥200	≥200	SB150-1.5T2	≥85	≥300
SB150-0.75S2	≥150	≥200	SB150-0.4T4	≥500	≥140
SB150-1.1S2	≥100	≥250	SB150-0.75T4	≥300	≥400
SB150-0.4T2	≥200	≥200	SB150-1.5T4	≥150	≥550
SB150-0.75T2	≥150	≥200			

3.4 Wiring



1. **Wiring of the inverter can be performed only by qualified professionals.**
2. **Before opening the cover board of the inverter, cut the power supply and wait for at least 10 minutes after all indicators on the keypad go out.**
3. **The wiring inside the inverter can only when the voltage between terminals DC+ and DC- is less than 36V.**
4. **The inverter must be earthed reliably, otherwise there may be a risk of electric shock or fire.**
5. **Shorting DC+ and DC- is prohibited. That may cause fire or damage to properties.**
6. **Connecting the power line with U, V or W is prohibited.**
7. **Before turning on the power verify the rated input voltage of the inverter is consistent with the voltage of the AC power supply, otherwise injury to people or damage to equipment may occur.**
8. **All terminals must be securely connected.**
9. **The output terminals U, V and W must be connected in strict phase order.**
10. **Connecting surge absorbing capacitors or voltage-dependent resistors on the output side of the inverter is prohibited.**

3 Installation and wiring

3.4.1 configuration of main circuit terminals

Basic wiring diagram is shown as below:

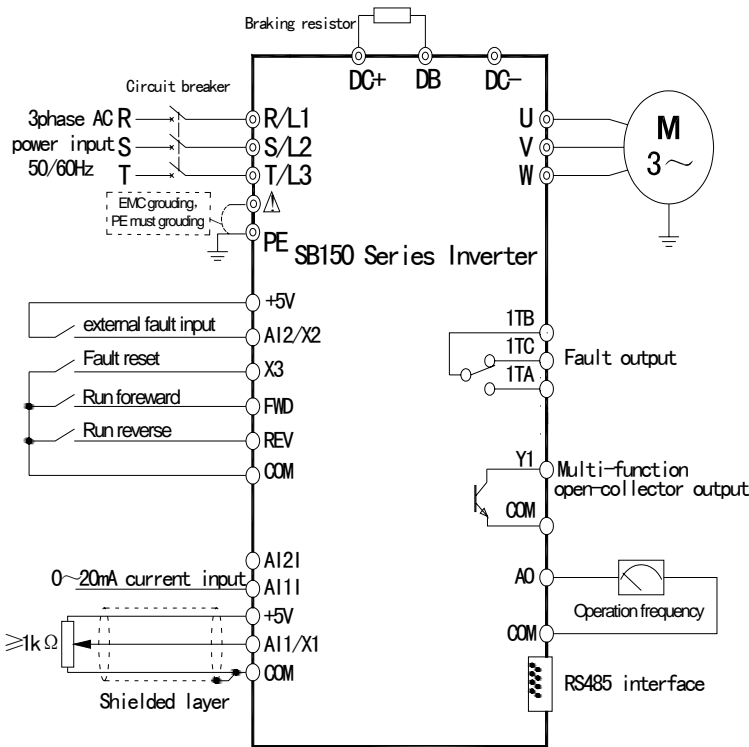

3.4.2 Wiring of main circuit terminals

Main circuit terminals:

Symbol	Terminal name	Description
R/L1、S/L2、T/L3	3phase Power input terminal	To 3-phase 220v/380V AC power supply. Note①
R/L1、T/L3	Inverter output terminal	To 1-phase 220v AC power supply. Note①
U、V、W	Inverter output terminal	3-phase AC output terminal
DC+、DC-	DC bus terminal	Connect a braking unit, common DC bus or external rectifying unit. Note②
DB	Braking output terminal	Braking resistor is connected between DC+ and DB
⚠	EMC Grounding terminal	Connect PE terminal when needed
PE	Grounding terminal	Connect the inverter case to earth.

Note①: When connect the power input line, please make sure the input power is in accordance with nameplate.

Note②: Contact us for the usage of the common DC bus main circuit terminals arrangement.

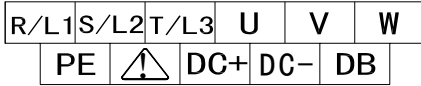

SB150-0.4~1.5 main circuit terminal bolt is M3.5, the fastening torque is,1.2~1.5 (N·m) , wire stripping length is 10mm.

The air switch, the main circuit wiring copper coil insulated conductor cross-section and its stripping length are recommended as follows:

Inverter model	Air switch (A)	Contactor (A)	Main circuit wiring (mm ²)		Grounding terminal PE wiring (mm ²)
			Input wiring	Output wiring	
SB150-0.4S2	16	10	2.5	2.5	2.5
SB150-0.75S2	25	16	2.5	2.5	2.5
SB150-1.1S2	32	25	4	2.5	2.5
SB150-0.4T2	10	10	2.5	2.5	2.5
SB150-0.75T2	16	10	2.5	2.5	2.5
SB150-1.5T2	25	16	2.5	2.5	2.5
SB150-0.4T4	10	10	2.5	2.5	2.5
SB150-0.75T4	10	10	2.5	2.5	2.5
SB150-1.5T4	16	10	2.5	2.5	2.5

3.4.3 Control board terminals and wirings

Control board terminals arrangement: (1mm² copper wires recommended as the terminals wirings, 5mm stripping length is recommended)

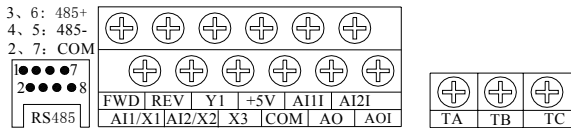

Functions of control board terminals:

Symbol	Name	Function and description	Specification
485+	485 differential signal (positive)	RS485 communication port	Connect 1~32 RS485 station(s) Input impedance: > 10kΩ
485-	485 differential signal (negative)		
COM	Ground	—	—

3 Installation and wiring

Symbol	Name	Function and description	Specification
+5V	+ 5V reference power supply	+5V power supply offered to user	+5V Max. output current is 10mA with the voltage accuracy better than 2%
Y1	digital output	digital output Refer to F5	Open collector output 24V DC/50mA Conducting voltage<0.5V
REV	REV digital input terminal	Refer to F4 digital input terminal: debounce time: 10ms Refer to F4	Input impedance $\geq 3k\Omega$ Input voltage range: <30V Sampling period: 1ms Debounce time: 10ms High level>10V Low level<4V Equivalent to “high level” if not connected
FWD	FWD digital input terminal		
X3	X3 digital input		
A11	Analog Channel1 Current Input	Analog input, refer F6-00~F6-09 Note①	As analog input: Input impedance: 300k Ω for voltage input or 125 Ω for current input Input voltage range: 0~+10V Input current range: 0~+20mA Digital input: high level>4V low level<2V Equivalent to “low level” if not connected
A11/X1	Analog Channel1 Voltage Input		
A12	Analog Channel2 Current Input		
A12/X2	Analog Channel2 Voltage Input		
AO	Analog Voltage Output	Multi-function analog output, refer to F6-10~F6-13 Note②	Current type : 0 ~ 20mA , load $\leq 500\Omega$ Voltage type : 0 ~ 10V , output $\leq 10mA$
AOI	Analog current output		
TA	Relay output terminal	Refer to F5	TA-TB: normally open TB-TC: normally closed Contacts: 250V AC/3A 24V DC/5A
TB			
TC			

注① Note①: SB150 inverter configure with two analog input channels, each channel can input current signal or voltage signal, in the function sheet, the two analog input channel is indicated by A11 and A12 separately.

A11/X1、A12/X2为模拟输入与数字输入复用端子，当作模拟输入时请将对应的数字输入功能设置为0。

Note② : SB150 inverter configure with one analog input channel, can be use as voltage output or current output, it is indicated by AO.

1) Wiring of analog input terminals

When analog signals are used for remote control, the control wires between the controller and inverter should be less than 30 meters in length. And since the analog signal is vulnerable to interference, the analog control wires should be laid apart from strong-electricity, relay or contactor circuit. The wiring should be shielded twisted pair cable and be as short as possible, with one of its end connected to the terminal COM of the inverter.

2) Wiring of multi-function output terminal Y1 and relay output terminal TA、TB、TC

If an inductive load, such as electromagnetic relay, contactor and electromagnetic brake, is driven, a surge voltage absorbing circuit, voltage-dependent resistor or continuous current diode(used in DC electromagnetic circuit. Be careful of the polarity during installation) should be installed. The components of the absorbing circuit should be installed near the sides of the winding of the relay or contactor, as shown below.

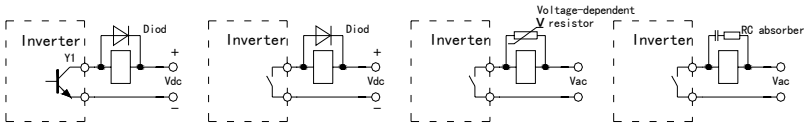

3.5 Methods of suppressing electromagnetic interference

The working principle of inverters decided that it would produce certain interference, and cause EMC problems to equipment or systems. Inverter is electrical equipment, it can also influenced by external electromagnetic interference. Below is the introduction of some installation design method which meet EMC regulations, it can provide the field installation and wiring reference of inverters.

Countermeasures against electromagnetic interference

Interference source	Countermeasure
Leakage current Ground loop	<p>When peripheral devices form a closed circuit through the wiring of the inverter, the leakage current from the earthing line of the inverter will cause false action of devices. To reduce false action, you may leave devices unearthed.</p> <p>Special ground (best) Common ground (good)</p>
Power cables	<p>When peripheral devices share the same power supply with the inverter, the interference generated by the inverter will transmit along the power line, causing false action of other devices in the same system. Following measures can be taken:</p> <p>(1) Install an EMI filter or ferrite common-mode filter(magnetic ring) on the input side of the inverter.</p> <p>(2) Isolate noise of other devices with an isolation transformer or power supply filter.</p>

3 Installation and wiring

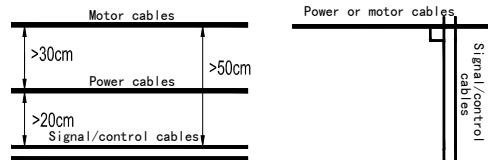
<p>Motor cable radiation</p> <p>Power cable radiation</p> <p>Inverter radiation</p>	<p>As measuring meters, radios, sensors or signal lines are installed in the same cabinet with the inverter, they are easy to be interfered with and act falsely. Following measures can be taken:</p> <p>(1) Install devices and signal lines which are easily affected as far as possible away from the inverter. The signal lines should be shielded wires and be earthed. They should be run in metal conduits, and be as far as possible away from the inverter and its input/output lines. If the signal lines have to cross the power cables, keep them at right angles.</p>  <p>(2) Install an EMI filter or ferrite common-mode filter(magnetic ring) on both input and output side of the inverter.</p> <p>(3) Motor cables should be laid in a thick shield, such as conduits(over 2mm) or cement tubes. The power cables should be run in metal conduits and be shielded and earthed(the motor cable is a 4-core cable, one end of which is connected to earth one the inverter side, while the other end is connected to the motor case).</p>
<p>Static induction</p> <p>Electromagnetic induction</p>	<p>(1) Avoid running signal lines in parallel with or in the same bundle with the power cables.</p> <p>(2) Try to keep devices and signal lines subject to disturbance as far as possible away from the inverter and its input and output lines.</p> <p>(3) Use shield wires as the signal lines and power cables and lay them in separate metal conduits, with the space between the two conduits being at least 20cm.</p>

2.Countermeasures against leakage current

Leakage current is generated due to the existence of capacitance between inverter input/output cables and earth, between lines and between the motor and earth. The size of the leakage current, including earth leakage current and inter-line leakage current, is determined by the size of the distributed capacitance and carrier frequency.

Sources of leakage current:

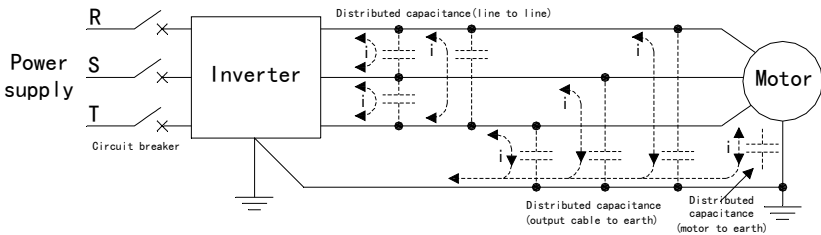

Earth leakage current

The leakage current may flow into not only the inverter system, but also other devices via the earth line, causing false action of the leakage circuit breaker, relay or other devices. The higher the carrier frequency and the longer the motor cables, the larger the leakage current.

Suppression measures: (1) Lower the carrier frequency, but that will increase the motor noise; (2) Minimize the length of the motor cables; (3) Use a leakage circuit breaker specially designed for higher harmonics and surge leakage current.

Inter-line leakage current

The higher harmonics of the leakage current from the inter-line distributed capacitance on the inverter output side may lead to false action of the external thermal relay, especially when the inverter has a small capacity and the wiring is very long (over 50m). Therefore we recommend you to use a temperature sensor to monitor the motor temperature directly or use the inverter's motor overload protection function to replace the external thermal relay.

Suppression measures: (1) Lower the carrier frequency; (2) Install a reactor on the output side.

4 Operation and commissioning

4.1 Operation and display

4.1.1 Functions of keypad

The keypad is used to set or browse parameters, control operations, display error information and so on. The appearance of the keypad is as follows.

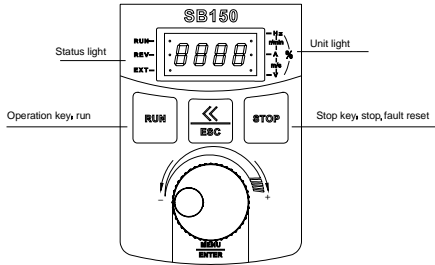

Description of keys on the keypad:

Key	Name	Function
	Menu/Enter	1、 Enter each menu 2、 Data storage confirmation
	Shift /Exit	1、 Select the data digit to be modified; switch between monitored parameters 2、 Under the status of parameter modification and return to the previous menu. 3、 Constantly press 3 seconds and return to the previous menu.
	Decrease number (-) Key	Inc/Dec number or data
	Increase number (+) Key	

Description of keys on the keypad:

Indicators	Unit	Indicators	Unit	Indicators	Unit
● — Hz r/min	Hz	○ — Hz r/min	A	○ — Hz r/min	V
○ — A % m/s		● — A % m/s		○ — A % m/s	
○ — V		○ — V		● — V	

Indicators	Unit	Indicators	Unit	Indicators	Unit
● — Hz r/min	r/min	○ — Hz r/min	m/s	● — Hz r/min	%
● — A m/s		● — A m/s		○ — A m/s	
○ — V		● — V		● — V	

Meanings of three indicators status

Indicator	Status	Inverter state
RUN indicator	Off	Standby state
	On	Stable run state
	Blinking	Accelerating or decelerating state
REV indicator	Off	Both preset and current direction are forward
	ON	Both preset and current direction are reverse
	Blinking	Preset direction is inconsistent with current direction
EXT indicator	Off	Keypad control
	ON	Terminal control
	Blinking	Communication control

4.1.2 Display status and operation of keypad

The keypad of SB150 has the following display status: monitoring status(including in standby state and in run state), parameter editing status, fault display status, alarm display status, etc.

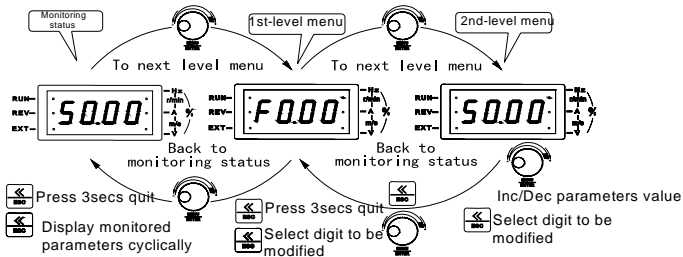

Monitoring status in standby state

Pressing  in this status cyclically displays the standby-state parameters (defined by FC-01~FC-04)

Monitoring status in run state

Pressing  in this status cyclically displays the run-state parameters(defined by FC-01~FC-07)

4 Operation and commissioning

Parameter editing status

In monitoring status, pressing  enters the editing status, which contains second level menus: parameter

group number→serial number in parameter group→parameter value. Pressing  enters the next menu and



pressing  3 second, returns to the previous menu(returns to monitoring status if at the first level menu).



Pressing  change the parameter group numbers, serial numbers in parameter group or parameter values. .

Under the second level menu, the digit which can be edited blinks. Pressing  switches the digit to be

edited to another digit, and pressing  saves the modified data and returns to the first level menu, and the next parameter is displayed.

Password check status

If there is a user password (F0-12 not equal to zero) , before you can edit any parameter you enter the password check status and “-----” is displayed. Input the password with  ,  (“-----” is displayed

during input) and press  If the password is not correct, “Err” blinks. At this moment, press 

returning to the password check status and press  again exiting the password check status. If there is no any keystroke within ten minutes, the password protection will take effect automatically.

Fault display status

Once the inverter detects a fault signal, the keypad enters the fault display status, and the error code blinks. The fault can be reset by inputting reset command ( key, control terminal or communication command). If the fault still exists, the error code continues to blink, during this period you can modify related parameters to eliminate the fault.

Alarm display status

When the inverter detects the alarm information, the alarm code blinks. If there are multiple alarm signals, the alarm codes display alternately. The alarm information can be temporarily hidden by pressing  or



. The alarm signal is automatically removed if normal state is recovered. The inverter does not stop in alarm display status.

4.2 Switching on the power for the first time

Connect the wires in accordance with the technical requirements specified in section 3.4.

After checking the wiring and power supply, close the air switch of the AC power on the inverter input side. “8.8.8.8.8” will first be displayed on the keypad of the inverter. When the contactor inside the inverter is closed normally, the display becomes the reference frequency. This shows the inverter initialization has been completed. If anything unusual occurs when the power is turned on, disconnect the air switch and check and remove the error.

4.3 Quick and optimize commissioning

SB150series inverter is controlled by keypad, the frequency setting is digital setting, refer to 3.4.1 to check the terminal function

Below is some common and necessary settings of SB150 inverter besides default setting.

- 1、 Frequency setting channel and reference frequency: refer to page 37;
- 2、 Command source: refer to F0-02, page40;
- 3、 Maximum frequency, upper-limit frequency lower-limit frequency and max. output voltage : refer to F0-06, F0-07, F0-08 and F2-10, make sure $F0-06 \geq F0-07 > F0-08$.
- 4 Motor run direction: refer to F0-05, page38;
- 5、 Accel/decel time: the accel/decel time should be as long as possible. Too short time will cause overcurrent or overlarge torque which damages the load, refer to page39;
- 6、 Start and stop mode: refer to F1-04 and F1-08, page 42;
- 7、 Motor parameters: rated power, motor pole number, rated current, rated frequency, rated speed and rated voltage. Refer to page 44。

SB150 optimize commissioning:

- 1、 F2-00“Manual torque uprising amplitude”： If the current at the start is too large, reduce the value, refer to page 42;
- 2、 It is recommended to boost the torque automatically in order to increase the inverter’s starting torque and its output torque at low speeds. , refer to page 42
- 3、 Slip compensation can ease the speed drop caused by the load. It is only valid when “auto torque boost” is valid, refer to page 43;

4 Operation and commissioning

4、 Vibration damping: If the motor vibrates, increase this parameter gradually until the vibration disappears.
Refer to **F2-06**.

5 Parameter table

Note: In the “Change” column of the table below, “O” indicates the parameter can be changed in any state, “×” indicates the parameter is only changeable in running state, while “△” indicates the parameter is read only.

F0 Basic Parameters

No.	Name	Setting range	Default	Change	page
F0-00	Digital reference frequency	0.00~650.00Hz	50.00Hz	○	37
F0-01	Main reference channel	0: F0-00digital setting 1: Communication 2: AI1 3: AI2 4: UP/DOWN value 5: Keypad POT	0	○	37
F0-02	Command source	1: Keypad 2: Terminal,  invalid 3: Terminal,  valid 4: Communication,  invalid 5: Communication,  valid	1	×	37
F0-03	Frequency holding	0: Saved upon power loss 1: Restored to F0-00 upon power loss 2: Restored to F0-00 upon power loss or stop Note: For keypad digital potentiometer, revise by  or communication setting	0	○	38
F0-04	Auxiliary reference channel	0: None 1: Communication setting 2: AI1 3: AI2 4: UP/DOWN value	0	○	38
F0-05	Direction lock	0: Forward or reverse 1: Forward only 2: Reverse only	0	○	38
F0-06	Max. frequency	0.00~650.00Hz	50.00Hz	×	38
F0-07	Upper-limit frequency	0.00~650.00Hz	50.00Hz	×	38
F0-08	Lower-limit frequency	0.00~650.00Hz	0.00 Hz	×	38
F0-09	Inverter rated capacity	Min. unit: 0.01kW	Depend s on model	△	38
F0-10	Software version	0.00~99.99	Depend s on version	△	38
F0-11	Parameter initialization	11: initialization 22: clean fault log	00	×	38
F0-12	User password	0000~9999, 0000 means no password	0000	○	38

5 Parameter table

F1 Accel/decel, start, stop and jog parameters

No.	Name	Setting range	Default	Change	Page
F1-00	Accel time 1	0.1~3600.0s	6.0s	○	39
F1-01	Decel time 1	Acceleration time: time period over which the frequency rises by 50Hz.			
F1-02	Accel time 2	Deceleration time: time period over which the frequency drops by 50Hz.			
F1-03	Decel time 2	Inc/Dec time 2 is also be used as jog Inc/Dec time.	0	×	39
F1-04	Starting mode	0: Start from starting frequency 1: Start from searched speed			
F1-05	Starting frequency	0.00~60.00Hz			
F1-06	Starting delay time	0.0~60.0s			
F1-07	Starting frequency duration	0.0~60.0s			
F1-08	Stop mode	0: Slowdown stop 1: Coast stop 2: Slowdown+DC braking			
F1-09	DC braking frequency (at stop)	0.00~60.00Hz			
F1-10	DC braking waiting time	0.0~10.0s			
F1-11	DC braking / Zero-speed delay time	0.0~60.0s	0.0s	○	40
F1-12	DC braking current	0.0~100.0%, rated current is100%	50.0%	○	41
F1-13	Jog frequency	0.10 ~ 50.00Hz, jog use the second set Inc/Dec time.	5.00Hz	○	41
F1-14	Accel/decel mode	0: Linear 1: S-curve	0	×	41
F1-15	S-curve accel start-stage time	0.01~10.00s	0.20s	○	41
F1-16	S-curve accel end-stage time	0.01~10.00s	0.20s	○	41
F1-17	S-curve decel start-stage time	0.01~10.00s	0.20s	○	41
F1-18	S-curve decel end-stage time	0.01~10.00s	0.20s	○	41

F2 V/F control parameters

No.	Name	Setting range	Default	Change	Page
F2-00	Manual torque boost level	0.0~15.0%	Depends on model	○	42
F2-01	Manual torque boost cut-off point	0.00~650.00Hz	50.00Hz	○	42

No.	Name	Setting range	Default	Change	Page
F2-02	Auto torque boost level	0.0~100.0%	80.0%	×	42
F2-03	Slip compensation gain	0.0~300.0%	0.0%	○	43
F2-04	Slip compensation filtering time	0.1~25.0s	1.0s	×	43
F2-05	Torque boost	0: No boost 2: Auto 1: Manual 3: Manual+auto	1	×	43
F2-06	Vibration damping	0~200	20	○	43
F2-07	AVR function	0: Inactive 2: Active except during decel 1: Active	1	×	44
F2-08	V/F curve	0: Linear 2: Reduced-torque V/F curve 2 (2.0) 1: Reduced-torque V/F curve 1 (1.5)	0	×	44
F2-09	Base frequency	1.00~650.00Hz	50.00Hz	×	44
F2-10	Max. output voltage	200V class: 75~250V, default 220V 400V class: 150~500V, default 380V	220V 380V	×	44

F3 Motor parameters

No.	Name	Setting range	Default	Change	Page
F3-00	Motor rated capacity	0.40~1.5kW	Depends on model	×	44
F3-01	Pole number	2~16	4	×	45
F3-02	Motor rated current	0.5~7.5A	Depends on model	×	45
F3-03	Motor rated frequency	20.00~650.00Hz	50.00Hz	×	45
F3-04	Rated rotation speed	12.5~4000 (x10) r/min	Depends on model	×	45
F3-05	Motor cooling condition	0: Common motor 1: Inverter-controlled motor	0	○	45
F3-06 ~ F3-09	Reserved	—	—	—	—

F4 Digital input terminals and multistep speed

No.	Name	Setting range	Default	Change	Page
F4-00	X1/AI1 terminal	0: No signal ±1: Multistep frequency 1 ±2: Multistep frequency terminal 2 ±3: Multistep frequency terminal 3 ±4: Accel/decel time select ±14: 3-wire stop command ±15: Internal virtual FWD ±16: Internal virtual REV ±17: Accel/decel disabled ±18: Run command switched to terminal or	0	×	45
F4-01	X2/AI2 terminal		5		
F4-02	X3 terminal		6		

5 Parameter table

No.	Name	Setting range	Default	Change	Page
F4-03	FWD terminal	±5: External fault input keypad. ±6: Fault reset ±7: Jog forward ±8: Jog reverse ±9: Coast stop / Operation disabled ±10: UP/DOWN increase ±11: UP/DOWN decrease ±12: UP/DOWN clear ±13: Process PID disabled	15		
F4-04	REV terminal	±19: Reference frequency switched to A11 ±20: Multi-PID select 1 ±21: Multi-PID select 2 ±22: Wobble frequency injection ±23: Wobble state reset Note : Plus sign means low level is valid, while minus sign means high level is valid	16		
F4-05	Digital input terminal anti-jittering time	0~2000ms	10ms	○	45
F4-06	FWD/REV mode	0: 1-wire mode(start/stop) 1: 2-wire mode 1(FWD, REV) 2: 2-wire mode 2(start/stop, direction) 3: 2-wire mode 3(start, stop) 4: 4-wire mode (pulse type start/stop, direction) 5: 3-wire mode 1(FWD, REV, stop) 6: 3-wire mode 2(run, direction, stop)	1	×	45
F4-07	UP/DOWN regulation mode	0: Level type(terminal) 1: Pulse type(terminal) 2: Level type(keypad) 3: Pulse type(keypad)	0	○	47
F4-08	UP/DOWN speed/step	0.01~100.00, unit is %/s or %	1.00	○	48
F4-09	UP/DOWN memory select	0: Stored on power loss 1: Cleared on power loss 2: Cleared at stop and on power loss	0	○	48
F4-10	UP/DOWN upper limit	0.0~100.0%	100.0%	○	48
F4-11	UP/DOWN lower limit	-100.0~0.0%	0.0%	○	48
F4-12 ~ F4-18	Multistep frequency 1~7	0.00~650.00Hz Note: The default values of multistep frequencies 1~7 are their respective frequency code numbers, for example, the default value of the multistep frequency 3 is 3.00Hz.	n.00Hz (n=1~7)	○	49

F5 Digital and relay outputs

No.	Name	Setting range	Default	Change	Page
F5-00	Y1 terminal	0: Inverter ready ±1: Inverter running ±2: Frequency reach ±3: Frequency reach ±7: Restart after momentary power failure ±8: Alarm output ±9: Reverse running	1	×	49

No.	Name	Setting range	Default	Change	Page
F5-01	T1 relay output	detection signal ±4: Fault output ±5: Undervoltage lockout ±6: Fault auto-reset ±10:Process PID sleep ±11: Wobble frequency upper/lower limit ±12: Feedback exceed upper limit alarm ±13:Feedback low lower limit alarm. Note: Set minus indicates output negate	4		
F5-02	T1 terminal closing delay	0.000~65.000s	0.000s	○	49
F5-03	T1 terminal opening delay		0.000s		
F5-04	Frequency reach detection band	0.00~650.00Hz	2.50Hz	○	50
F5-05	Frequency reach detection level	0.00~650.00Hz	50.00Hz	○	50
F5-06	Frequency reach detection hysteresis	0.00~650.00Hz	1.00Hz	○	51

F6 Analog and pulse frequency terminals

No.	Name	Setting range	Default	Change	Page
F6-00	A11 Min. input analog quantity	0.00~100.0%	0	○	51
F6-01	A11 Max. input analog quantity		100.0%		
F6-02	A11 Min. input analog quantity corresponding set value/feedback value	0~100.00% Note: set frequency use max. frequency as reference value.	0.00%	○	51
F6-03	A11 Max. input analog quantity corresponding set value/feedback value	PID setting/feedback use percentage of PID reference scalar.	100.0%	○	51
F6-04	A11 filtering time	0.000~10.000s	0.100s	○	51
F6-05	A12 Min. input analog quantity	0.00~100.0%	0	○	51
F6-06	A12 Max. input analog quantity		100.0%		
F6-07	A12 Min. input analog quantity corresponding set value/feedback value	0.00~100.00% Note: set frequency use max. frequency as reference value.	0.00%	○	52
F6-08	A12 Max. input analog quantity corresponding set value/feedback value	PID setting/feedback use percentage of PID reference scalar.	100.0%	○	52
F6-09	A12 filtering time	0.000~10.000s	0.100s	○	52

5 Parameter table

No.	Name	Setting range	Default	Change	Page
F6-10	AO function selection	1: Operating frequency 2: Reference frequency 3: Output current 4: Output voltage 5: Output capacity 6: PID feedback value 7: PID reference value 8: AI1 9: AI2 11: UP/DOWN value 12: DC bus voltage	1	○	53
F6-11	AO type	0: 0~10V or 0~20mA 1: 2~10V or 4~20mA 2: 5V at the center	0	○	53
F6-12	AO gain	0.0~1000.0%	100.0%	○	53
F6-13	AO bias	-19.99~99.99%, 10V or 20mA is 100%	0.00%	○	53

F7 Process PID parameters

No.	Name	Setting range	Default	Change	Page
F7-00	PID control select	0: PID control disabled 1: PID control enabled 2: PID corrects reference frequency	0	×	54
F7-01	PID reference channel	0: F7-04 1: AI1 2: AI2 3: AI1-AI2 4: AI1+AI2 5: UP/DOWN value 6: keypad potentiometer value 7: Communication setting	0	×	55
F7-02	feedback channel	1: AI1 2: AI2 3: AI1-AI2 4: AI1+AI2	1	×	55
F7-03	PID reference scalar	-100.0~100.0	10.00	×	55
F7-04	PID digital reference	-100.0~100.0	5.0	○	55
F7-05	PID regulation characteristic	0: Positive 1: Negative	0	×	55
F7-06	Proportional gain	0.00~100.00	1.00	○	55
F7-07	Integral time	0.00~100.00s, 0 indicates no integral	2.00s	○	55
F7-08	Differential time	0.000~10.000s	0.000s	○	55
F7-09	Sampling period	0.001~10.000s	0.010s	○	56
F7-10	PID upper limit	-100.0~100.0%(Max frequency=100%)	100.0%	○	56
F7-11	PID lower limit		0.0%		
F7-12	Multi-PID setpoint 1	-100.0~100.0	1.0	○	56
F7-13	Multi-PID setpoint 2		2.0	○	56
F7-14	Multi-PID setpoint 3		3.0	○	56
F7-15	Sleeping frequency	0.00~650.00Hz	40.00Hz	○	56
F7-16	Sleeping waiting time	0.0~3600.0s	60.0s	○	56

No.	Name	Setting range	Default	Change	Page
F7-17	Awaken deviation	0.00 ~ 100.00%, Note: 100.00% sleeping invalid	100.00%	○	56
F7-18	Awaken delay time	0.000~60.000s	0.500s	○	56
F7-19	Feedback exceed upper limit alarm value	50.0~200.0%	120.0%	○	57
F7-20	Feedback exceed upper limit hysteresis loop value	0.0~100.0%	10.0%	○	57
F7-21	Feedback under lower limit alarm value	0.0~100.0%	40.0%	○	57
F7-22	Feedback under lower limit hysteresis loop value	0.0~50.0%	10.0% _s	○	57

F9 Wobble frequency control

No.	Name	Setting range	Default	Change	Page
F9-00	Wobble frequency injection mode	0: Disabled 1: Auto injection 2: Manual injection	0	×	57
F9-01	Wobble amplitude control	0: Center frequency=100% 1: Max. frequency=100%	0	×	58
F9-02	Preset wobble frequency	F0-08 ~ F0-07	0.00Hz	○	58
F9-03	Preset wobble frequency waiting time	0.0 ~ 3600.0s	0.0s	○	58
F9-04	Wobble frequency amplitude	0.0 ~ 50.0% (relative to center frequency or Max. frequency)	0.0%	○	58
F9-05	Sudden jump frequency	0.0 ~ 50.0% (actual wobble frequency amplitude=100%)	0.0%	○	58
F9-06	Sudden jump time	0 ~ 50ms	0ms	○	58
F9-07	Wobble period	0.1 ~ 1000.0s	10.0s	○	58
F9-08	Rising time	0.0 ~ 100.0%, (F9-07=100%)	50.0%	○	58
F9-09	Wobble randomness	0.0 ~ 50.0%, (F9-07=100%)	0.0%	○	58
F9-10	Wobble restart and power-off setting	0: Smooth restart 1: Restart from zero	0	×	58

Fb Protection functions and advanced settings

No.	Name	Setting range	Default	Change	Page
Fb-00	Motor overload protection value	50.0 ~ 150.0% (motor rated current=100%)	100.0%	○	60
Fb-01	Motor overload action	0: No action 1: Continue running with an alarm 2: Coast to a stop due to fault	2	×	60

5 Parameter table

No.	Name	Setting range	Default	Change	Page
Fb-02	Analog input disconnection action	0: No action 1: alarm 2: alarm, press F0-00 3: Coast to a stop, with an Er.Aco alarm	0	×	60
Fb-03	Phase lose protection	0: No action 1: only input 2: only output 3: input and output	3	×	61
Fb-04	overcurrent stall point	0.0 ~ 150.0 % (inverter rated current=100%) 0.0 shows invalid	150.0%	×	61
Fb-05	Overvoltage stall point	200V class: 325~375V, default 350V 400V class: 650~750V, default 700V	350V 700V	×	61
Fb-06	DC link undervoltage action	0: Coast to a stop and report the undervoltage fault(Er.dcl) 1: Coast to a stop, and restart when power up	0	×	61
Fb-07	DC link undervoltage point	200V class: 185~240V, default 200V 400V class: 370~480V, default 400V	200V 400V	×	61
Fb-08	Auto reset times	0~10, module protection and external fault have no reset function	0	×	62
Fb-09	Auto reset interval	1.0~30.0s	5.0s	×	62
Fb-10	Fault output during auto reset	0: No output 1: Output	0	×	62
Fb-11	Power-on auto reset	0: Disabled 1: Enabled	1	○	62
Fb-12	Built-in braking unit working threshold	200V class: 310~360, default 340V 400V class: 620~720V, default 680V	340V 680V	○	62
Fb-13	Carrier frequency	1.1k~16.0kHz	4.0kHz	○	63
Fb-14	Carrier frequency auto adjustment	0: Disabled 1: Enabled	1	○	63
Fb-15	Jump frequency	0.00~625.00Hz	0.00Hz	○	63
Fb-16	Jumping width	0.00~20.00Hz	0.00Hz	○	63

FC Display Settings

No.	Name	Setting range	Default	Change	Page
FC-00	Display parameter selection	0: All 1: Different from default value	0	○	63
FC-01	Monitored parameter 1(run & stop)	0~17, 0~17 indicate FU-00~FU-17	1	○	63
FC-02	Monitored parameter 2(run & stop)	-1~17	-1	○	64
FC-03	Monitored parameter 3(run & stop)	-1 indicates empty, 0~17 indicate FU-00~FU-17	-1	○	64
FC-04	Monitored parameter 4(run & stop)		-1	○	64

No.	Name	Setting range	Default	Change	Page
FC-05	Monitored parameter 1(run)	-1~17	0	○	64
FC-06	Monitored parameter 2(run)	-1 indicates empty, 0~17 indicate FU-00~FU-17	2	○	64
FC-07	Monitored parameter 3(run)		4	○	64
FC-08	Speed display coefficient	0.001~10.000	1.000	○	64
FC-09	Line speed display coefficient	0.01~100.00	0.01	○	64

FF Communication Parameter

No.	Name	Setting range	Default	Change	Page
FF-00	Communication data format	0: 8,N,1 1: 8,E,1 2: 8,O,1 3: 8,N,2	0	×	64
FF-01	Baud rate selection	0: 1200bps 1: 2400bps 2: 4800bps 3: 9600bps 4: 19200bps	3	×	64
FF-02	Local address	1~247, 248 is master	1	×	64
FF-03	Communication overtime detection time	0.1~600.0s	10.0s	○	64
FF-04	Communication overtime action	0: No action 1: Alarm 2: Motor runs at F0-00 with alarm 3: Motor coasts to a stop due to fault	0	×	65
FF-05	Master and slave Operation procedure	0: Frequency reference value 1: PID reference value.	0	×	64
FF-06	Slave reference scale coefficient	0.01-100.00	1.00	○	65

Fn Factory parameters

FP Fault record

No.	Name	Description
-----	------	-------------

5 Parameter table

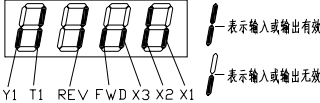
No.	Name	Description
FP-00	Last fault type	0: No fault 1. ocb: Momentary overcurrent at start 2. ocA: Overcurrent in accel 3. ocd: Overcurrent in decel 4. ocn: Overcurrent in constant-speed run 5. ouA: Overvoltage in accel 6. oud: Overvoltage in decel 7. oun: Overvoltage in constant-speed run 8. ouE: Overvoltage in standby state 9. dcL: Undervoltage in run 10. PLI: Input phase loss 11. PLo: Output phase loss 12. FoP: Power device protection 13. oHI: Inverter overheating 14. oLI: Inverter overload 15. oLL: Motor overload 16. EEf: External fault 22. CFf: Communication error 23. ccF: Current check error 19: Aco : Analog input disconnection 20: rHo: Thermal sensitive resistor open 21: Io1 Reserved 22: Io2 Reserved
FP-01	Cumulated run time at last fault	Min. unit : 1h
FP-02	Operating frequency at last fault	Min. unit: 0.01Hz
FP-03	Reference frequency at last fault	Min. unit: 0.01Hz
FP-04	Output current at last fault	Min. unit: 0.1A
FP-05	Output voltage at last fault	Min. unit: 0.1V
FP-06	Output capacity at last fault	Min. unit: 0.1kW
FP-07	DC link voltage at last fault	Min. unit: 0.1V
FP-08	Bridge temperature at last fault	Min. unit: 0.1°C
FP-09	Terminal status at last fault	
FP-10	2nd last fault type	Same as FP-00
FP-11	Cumulated run time at 2nd last fault	Min. unit: 1h
FP-12	Operating frequency at 2nd last fault	Min. unit: 0.01Hz
FP-13	Reference frequency at 2nd last fault	Min. unit: 0.01Hz
FP-14	Output current at 2nd last fault	Min. unit: 0.1A
FP-15	Output voltage at 2nd last fault	Min. unit: 0.1V
FP-16	Output capacity at 2nd last fault	Min. unit: 0.1kW
FP-17	DC link voltage at 2nd last fault	Min. unit: 0.1V
FP-18	Bridge temperature at 2nd last fault	Min. unit: 0.1°C
FP-19	Terminal status at 2nd last fault	Same as FP-09
FP-20	3rd last fault type	Same as FP-00
FP-21	Cumulated run time at 3rd last fault	Min. unit: 1h

No.	Name	Description
FP-22	Operating frequency at 3rd last fault	Min. unit: 0.01Hz
FP-23	Reference frequency at 3rd last fault	Min. unit: 0.01Hz
FP-24	Output current at 3rd last fault	Min. unit: 0.1A
FP-25	Output voltage at 3rd last fault	Min. unit: 0.1V
FP-26	Output capacity at 3rd last fault	Min. unit: 0.1kW
FP-27	DC link voltage at 3rd last fault	Min. unit: 0.1V
FP-28	Bridge temperature at 3rd last fault	Min. unit: 0.1°C
FP-29	Terminal status at 3rd last fault	Same as FP-09
FP-30	4th Last fault type	Same as FP-00
FP-31	Cumulated run time at 4th last fault	Min. unit: 1h
FP-32	Operating frequency at 4th last fault	Min. unit: 0.01Hz
FP-33	Reference frequency at 4th last fault	Min. unit: 0.01Hz
FP-34	Output current at 4th last fault	Min. unit: 0.1A
FP-35	Output voltage at 4th last fault	Min. unit: 0.1V
FP-36	Output capacity at 4th last fault	Min. unit: 0.1kW
FP-37	DC link voltage at 4th last fault	Min. unit: 0.1V
FP-38	Bridge temperature at 4th last fault	Min. unit: 0.1°C
FP-39	Terminal status at 4th last fault	Same as FP-09
FP-40	5th Last fault type	Same as FP-00
FP-41	Cumulated run time at 5th last fault	Min. unit: 1h
FP-42	Operating frequency at 5th last fault	Min. unit: 0.01Hz
FP-43	Reference frequency at 5th last fault	Min. unit: 0.01Hz
FP-44	Output current at 5th last fault	Min. unit: 0.1A
FP-45	Output voltage at 5th last fault	Min. unit: 0.1V
FP-46	Output capacity at 5th last fault	Min. unit: 0.1kW
FP-47	DC link voltage at 5th last fault	Min. unit: 0.1V
FP-48	Bridge temperature at 5th last fault	Min. unit: 0.1°C
FP-49	Terminal status at 5th last fault	Same as FP-09

FU Data monitoring

No.	Name	Description
FU-00	Operating frequency	Motor speed frequency, Min. unit: 0.01Hz
FU-01	Reference frequency	Unit indicator blinks, Min. unit: 0.01Hz
FU-02	Output current	Min. unit: 0.1A

5 Parameter table

No.	Name	Description
FU-03	Load current percentage	Inverter rated current=100%, Min. unit: 0.1%
FU-04	Output voltage	Min. unit: 0.1V
FU-05	Operating speed	Min. unit: 1r/min
FU-06	Reference speed	Unit indicator blinks, Min. unit: 1r/min
FU-07	DC link voltage	Min. unit: 0.1V
FU-08	Output capacity	Min. unit: 0.1kW
FU-09	Operating line speed	Min. unit: 1m/s
FU-10	Reference line speed	Unit indicator blinks, Min. unit: 1m/s
FU-11	PID feedback	Min. unit: 0.1%
FU-12	PID reference	Unit indicator blinks, Min. unit: 0.1%
FU-13	AI1	Min. unit: 0.1%
FU-14	AI2	Min. unit: 0.1%
FU-15	UP/DOWN value	Unit indicator blinks, Min. unit: 0.1%
FU-16	digital input/output terminal status	<p>Y1 T1 REV FWD X3 X2 X1</p> <p>— 表示输入或输出有效 — 表示输入或输出无效</p>
FU-17	Heat sink temperature	Min. unit: 0.1°C
FU-18~FU-24		Reserved

6 Parameter Description

6.1 F0 Basic Parameters

F0-00	Digital reference frequency	Default	50.00Hz	Change	○
Setting range	0.00~650.00Hz				
F0-01	Main reference channel	Default	0	Change	○
Setting range	0: F0-00digital setting 1: Communication(F0-00 as initial value) 2: AI1 3: AI2 4: UP/DOWN value 5: Keypad POT				

The reference frequency channels are shown in the following diagram:

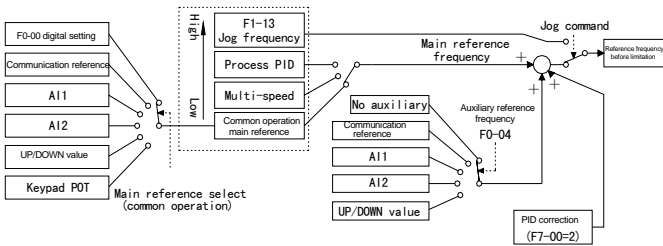





- 📖 The inverter has 4 operation modes and their priorities are: jog>process PID>multi-speed>common operation. For example, if multi-speed operation is valid when the inverter is in common operation, the main reference frequency will be determined by the multistep frequency.
- 📖 In common operation, the main reference frequency can be selected by F0-01, and the frequency setting channel can be compulsively switched to AI1 and Arithmetic unit 1 by digital input 19, (for functions of digital input, refer to [Section](#)
- 📖 Under the terminal or communication control, jog run can be achieved by digital inputs 7 and 8.
- 📖 The reference frequency is restricted by F0-07 and F0-08.

F0-02	Command source	Default	1	Change	×
Setting range	1: Keypad(EXT off) 2: Terminal, <input type="checkbox"/> STOP invalid, (EXT on) 3: Terminal, <input type="checkbox"/> STOP valid, (EXT on) 4: Communication, <input type="checkbox"/> STOP invalid, (EXT blinks) 5: Communication, <input type="checkbox"/> STOP valid, (EXT blinks)				

- 📖 When keypad is selected as the command source, power on default direction is forward.
- 📖 Digital input 18 can compulsively switch the command source, refer to [section](#) .

6 Parameter Description

F0-03	Frequency holding	Default	0	Change	○
Setting range	0: power failure.  or communication is stored in F0-00. 1: power failure  or communication is stored in F0-00. 2: power failure、stop state  or communication is stored in F0-00.				

 This parameter is valid only when F0-01=0 or 1.

F0-04	Auxiliary reference channel	Default	0	Change	○
Setting range	0: None 1: Communication reference 2: All 3: AI2 4: UP/DOWN value				

 Refer to F0-00 and F0-01

F0-05	Direction lock	Default	0	Change	○
Setting range	0: Forward or reverse 1: Forward only 2: Reverse only				

 It is recommended to set F0-05 to 1 or 2 when only a single direction is required.

F0-06	Max. frequency	Default	50.00Hz	Change	×
		Default	50.00Hz	Change	×
		Default	0.00Hz	Change	×
Setting range	0.00~650.00Hz				

 F0-06 “Max. Frequency”: This is the frequency corresponding with a frequency setting of 100%. use for PID control or analog input, keypad potentiometer frequency setting.

 F0-07 “Upper Frequency Limit”/F0-08 “Lower Frequency Limit”: Limits for the final frequency settings.

 Make sure F0-06 ≥F0-07 >F0-08.

F0-09	Inverter rated capacity	Default	Depends on model	Change	△

 The minimum unit is 0.01kW.

F0-10	Software version	Default	Depend on Version	Change	△

 The setting range is between 0.00 and 99.99.

F0-11	Parameter protection	Default	00	Change	×
Setting range	11: Initialization 22: Initialization applicable to all parameters except communication parameters NOTE: The parameter automatically changes to 00 upon completion of initialization				

 Parameter initialization restores a parameter to factory settings and the fault logs are not restored

F0-12	User password	Default	0000	Change	○
Setting Range	0000~9999; 0000 indicate an ineffective password. Note: when the code is set, do not press any key in 10s, then the code is valid.				

6.2 F1: Acceleration/Deceleration, Startup, Shutdown and Jog Parameters

F1-00	Acceleration Time 1	Factory Settings	6.0s	Change	○
F1-01	Deceleration Time 1	Factory Settings	6.0s	Change	○
F1-02	Acceleration Time 2	Factory Settings	6.0s	Change	○
F1-03	Deceleration Time 2	Factory Settings	6.0s	Change	○
Setting range	0.1~3600.0s				

 F1-00~F1-03 provide two sets of accel/decel time. Digital input 4 can be used to select the 2nd set of accel/decel time, i.e. accel/decel time 2.

 Accel(decel) time is the time period over which the frequency increases(decreases) by 50Hz.

 Accel and decel time 2 are also used as the accel and decel time for jog run respectively.

F1-04	Startup Mode	Factory Settings	0	Change	×
Setting Range	0: Startup from the startup frequency mode 1: Startup in the rotation speed tracking mode				
F1-05	Startup Frequency	Factory Settings	0.50Hz	Change	○
Setting Range	0.00~60.00Hz				
F1-06	Startup Delay Time	Factory Settings	0.0s	Change	○
Setting Range	0.0~3600.0s				
F1-07	Startup Frequency Maintenance Time	Factory Settings	0.0s	Change	○
Setting Range	0.1~60.0s				

 Inverter Startup Modes:

When **F1-04=0**, the inverter will start up from the startup frequency: After startup, the inverter will operate at the “startup frequency”F1-05, which is maintained for a time set by F1-07“Startup Frequency Maintenance Time”. This is intended to reduce the impact current at startup.; when F1-05=0, set suitable maintenance time and torque uprising, it can achieve the function of DC braking before start.

When **F1-04=1**, the inverter will startup in a rotation speed tracking mode. The inverter will automatically identify the motor rotation speed/direction prior to motor startup and then start up the motor smoothly from the corresponding frequency without producing any impact. It is not necessary to wait until running motor stops thoroughly before enforcing a restart. You may minimize the startup time and impact.

When restart from sudden stop or fault, it can be set to “speed flying start”

6 Parameter Description

 **F1-06:** When receiving the operation command, run it after delay the set time

 NOTE: It is inadvisable to restart after a prolonged DC braking in the event of a high-speed startup or startup with great-inertia loads. Tracking startup is recommended.

 NOTE: If the inverter is started immediately after a free shutdown, the remanence of the counter-electromotive force will cause an overcurrent. Therefore, if the motor requires an immediate startup when it is still running after a free shutdown, tracking startup is recommended.

F1-08	Shutdown Mode	Factory Settings	0	Change	○
Setting Range	0: Shutdown in deceleration mode 1: Free shutdown 2: Deceleration+ DC braking +DC Braking				
F1-09	Shutdown/DC Braking Frequency	Factory Settings	0.50Hz	Change	○
Setting Range	0.00~60.00Hz				
F1-10	Shutdown DC Braking Latency Time	Factory Settings	0.0s	Change	○
Setting Range	0.0~10.0s				
F1-11	DC braking/zero-speed delay time	Default	0.0s	Change	○
Setting Range	0.0~60.0s				
F1-12	Shutdown DC Braking Current	Factory Settings	50.0%	Change	○
Setting Range	0.0~100.0%; the rated inverter current is taken as 100%				

 Inverter Shutdown Mode:

When **F1-08=0**, the inverter will shut down in an deceleration mode: When it drop to F1-09, enter standby mode or enter the zero-speed delay state at F1-11 ≠0, please check the descriptions below:

When F1-08=1, the inverter will have a free shutdown. The inverter will lock the output and the motor will slide freely to a shutdown. But if it is a jog shutdown or an emergency shutdown, the deceleration-mode shutdown will still be effective. Generally, a free shutdown is not recommended for water pumps, because the pump has a shorter shutdown time and a sudden shutdown may cause a water hammer effect.

When F1-08=2 the “shutdown in deceleration mode + DC Braking” will be effective: Upon receipt of the shutdown command, the inverter will decelerate; when **F1-08**“shutdown/DC braking frequency” is actuated, the output will be clocked. After **F1-10**“shutdown DC braking latency time”, provide a DC current for the motor as directed by **F1-12**“Shutdown DC Braking Current”. After the settings for **F1-11**are actuated, the motor will shut down.

 CAUTION: DC braking is recommended only for low-speed operation (10Hz and below) or small-power motors.

 CAUTION: In a DC braking, the mechanical energy of the load is transferred to the rotor. Frequent or longtime DC braking may cause a motor overheat.

过热。

- 📖 **Zero-speed delay:** Under the slowdown stop mode(F1-08=0), when the frequency drops to F1-09, the motor continues decelerating to zero within the time set by F1-11 and keeps running at zero frequency. By dosing so, the motor keeps being excited so that it can be started quickly at any moment. The process of zero-speed delay is shown as below.

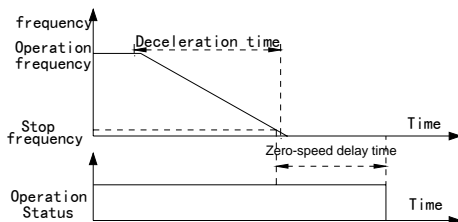

F1-13	Jog Frequency	Factory Settings	5.00Hz	Change	○
Setting Range	0.10~50.00Hz				

- 📖 Digital input 7 or 8 is used to activate jog run. Jog is invalid if both inputs are valid or invalid. Jog is only valid for terminal control or communication control.
- 📖 Under jog run mode, auxiliary reference and PID frequency correction are invalid.
- 📖 The jog start/stop mode is: start from starting frequency+slowdown stop+accel/decel time 2.

F1-14	Accel/decel mode	Factory Settings	0	Change	×
Setting Range	0: Linear 1: S-curve				
F1-15	S-curve accel start-stage time	Factory Settings	0.20s	Change	×
F1-16	S-curve accel end-stage time	Factory Settings	0.20s	Change	×
F1-17	S-curve decel start-stage time	Factory Settings	0.20s	Change	×
F1-18	S-curve decel end-stage time	Factory Settings	0.20s	Change	×
Setting Range	0.01~10.00s				

- 📖 In S-curve accel/decel mode, the acceleration and speed change gradually and smoothly, which is helpful to raise the comfort degree in elevators, prevent the falling of objects on conveyors, or reduce the impact to equipment at the start/stop.
- 📖 The total accel/decel time is extended after the S-curve accel/decel time is set, as shown below.

6 Parameter Description

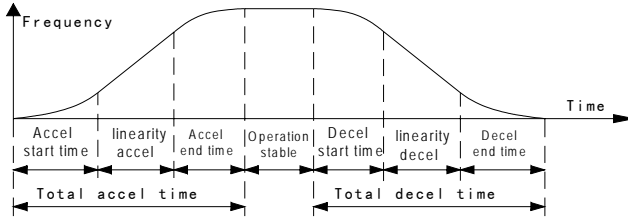

The calculation formula for the total accel/decel time is:

$$\text{Total accel/decel time} = \text{accel/decel time for non S-curve} + (\text{accel/decel start-stage time} + \text{accel/decel end-stage time}) \times 2$$

If the total accel/decel time obtained from the above formula is less than the sum of accel/decel start-stage time and accel/decel end-stage time, then:

$$\text{Total accel/decel time} = \text{accel/decel start-stage time} + \text{accel/decel end-stage time}$$

6.3 F2 V/F Control Parameters

F2-00	Amplitude of Manual Torque Elevation	Factory Settings	Depend on inverter model No.	Change	○
Setting Range	0.0~15.0%, F2-10“max. output voltage” is taken as 100%				
F2-01	Cut-Off Point of Manual Torque Elevation	Factory Settings	50.00Hz	Change	○
Setting Range	0.00~650.00Hz				
F2-02	Auto Torque Elevation Range	Factory Settings	80.0%	Change	×
Setting Range	0.0~100.0%				

- 📖 Manual torque boost is valid when F2-05=1 or 3, while auto torque boost is valid when F2-05=2 or 3.
- 📖 Manual torque elevation can improve the low-speed torque and startup torque of the motor. Tune up F2-00 “Amplitude of Manual Torque Elevation” until the startup requirements are met. The amplitude value must not be too great, otherwise there will be motor overheating or overcurrent.
- 📖 The relation curve of output voltage (V) and frequency (F) consists of a setup V/F curve, manual torque elevation and auto torque elevation. Please refer to the following figure for the relation between F2-00 “Amplitude of Manual Torque Elevation”, F2-01 “Cut-Off Point of Manual Torque Elevation”, F2-09 “Basic frequency” and F2-10 “max. output voltage”:

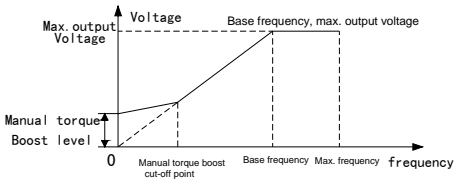

Auto torque elevation can change the voltage real-time according to the load current intensity, compensate the voltage loss of the stator impedance, automatically adapt to different loads and output appropriate voltage. This function can ensure larger output torque under heavy loads and smaller output currents under zero load.



F2-03	Slip Compensation Gain	Factory Settings	0.0%	Change	○
Setting Range	0.0~300.0%				
F2-04	filter Time of Slip Compensation	Factory Settings	1.0s	Change	×
Setting Range	0.1~25.0s				

Slip compensation is effective in chases where auto torque elevation is enabled (F2-05=2 or 3)

Slip Compensation: If the output frequency remains unchanged, the load change may cause a slip change and the rotation speed will drop. Slip compensation supports online adjustment of the inverter's output frequency according to load torque, minimizes change in rotation speed with load and improves speed control accuracy.

Slip compensation may be adjusted by F2-03 "Slip Compensation Gain". It is recommended that the adjustment be done according to the drop of the rotation speed when the motor temperature is relatively stable under load operation. If the slip compensation gain is 100%, it means that the compensation value at the rated torque is the rated slip frequency.

Formula of Rated slip frequency: Rated slip frequency = Rated frequency — (Rated rotation speed × Number of poles ÷ 120)

If the motor oscillates in the course of slip compensation, tune up F2-04 "Filter time of slip compensation".

F2-05	Torque Elevation Options	Factory Settings	1	Change	×
Setting Range	0: 无 1: Manual torque elevation only 2: Auto torque elevation only 3: Manual torque elevation + auto torque elevation				

Refer to F2-00~F2-02.

F2-06	Vibration damping	Factory Settings	20	Change	○
Setting Range	0~200				

Increasing this parameter can suppress the motor vibration under the no-load or light-load condition.

6 Parameter Description

F2-07	AVR Settings	Factory Settings	1	Change	×
Setting Range	0: Inactive 1: Active 2: Active except during decel				

- 📖 AVR is automatic voltage regulation. It keeps the output voltage unaffected when the input voltage or DC link voltage alters, thus stabilizing the production process and product quality.
- 📖 When the input voltage is higher than the rating, the AVR function should be enabled so that the motor would not run under an overhigh voltage.
- 📖 Setting F2-10 to 2 allows a quicker deceleration and generates a higher current compared with setting it to 1, because deceleration would raise the DC link voltage and then the output voltage if AVR is inactive, which leads to a greater motor loss and less mechanical energy feedback, therefore the deceleration time can be shorter.

⚠ CAUTION: If the load has a very large moment of inertia, F2-10 should be set to 1 to prevent the overhigh voltage causing motor overheating during deceleration.

F2-08	V/F curve	Default	0	Change	×
Setting range	0: Linear V/F curve (1st power) 1: Reduced-torque V/F curve 1 (1.5th power) 2: Reduced-torque V/F curve 2 (2.0th power)				

- 📖 V/F curve can be a self-defined linear line or 2 reduced-torque curve.
- 📖 A reduced-torque V/F curve can improve the efficiency of the motor of a reduced-torque load (such as a fan or pump) in light-load operation.
- 📖 Apart from improving the motor efficiency, the reduced-torque V/F curve and auto energy-saving operation can decrease the noise.

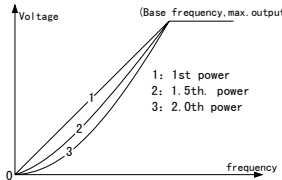

F2-09	Base frequency	Default	50.00Hz	Change	×
Setting range	1.00~650.00Hz				
F2-10	Max. output voltage	Default	380V	Change	×
Setting range	150~500V				

📖 Refer to F2-00~F2-02.

6.4 F3 Motor parameters

F3-00	Motor rated capacity	Default	Depends on model	Change	×
Setting range	0.40~1.5kW				

F3-01	Pole number	Default	4	Change	×
Setting range	2~16				
F3-02	Motor rated current	Default	Depends on model	Change	×
Setting range	0.5~7.5A				
F3-03	Motor rated frequency	Default	50.00Hz	Change	×
Setting range	20.00~650.00Hz				
F3-04	Motor rated speed	Default	Depends on model	Change	×
Setting range	12.5~4000 (x10) r/min				
F3-05	Motor cooling condition	Default	0	Change	○
Setting range	0: Common motor 1: Inverter-controlled motor				
F3-06~F3-09	reserved				

 Be sure to input the motor nameplate parameters F3-00~F3-05 before running the inverter.

The common motor has a self-cooling fan, which has a poorer cooling effect at low speeds and the motor overload protection level drops at low speeds, while the special motor for inverter has a separate cooling fan which ensures the motor has the same overload protection level at high and low speeds. For the function of motor overload protection, refer to Fb-00 and Fb-01.



6.5 F4 Digital input terminals and multistep speed

F4-00	X1/AI1 terminal	Default	0	Change	×
F4-01	X2/AI2 terminal	Default	5	Change	×
F4-02	X3 terminal	Default	6	Change	×
F4-03	FWD terminal	Default	15	Change	×
F4-04	REV terminal	Default	16	Change	×
Setting range	0: No signal ±1: Multistep frequency 1 ±2: Multistep frequency 2 ±3: Multistep frequency 3 ±4: Accel/decel time select 2 ±5: External fault input ±6: Fault reset ±7: Jog forward ±8: Jog reverse ±9: Coast stop/run disabled ±10: UP/DOWN increase ±11: UP/DOWN decrease ±12: UP/DOWN clear ±13: Process PID disabled ±14: 3-wire stop command ±15: Internal virtual FWD terminal ±16: Internal virtual REV terminal ±17: Accel/decel disabled ±18: Run command source switched to terminal/keypad ±19: Reference frequency switched to AI1 ±20: Multi-PID select 1 ±21: Multi-PID select 2 ±22: Wobble frequency injection ±23: Wobble state reset Note: set as plus low level is valid, Set as minus high level is valid				

 If F4-00~F4-06 select the same function, the parameter with the largest serial number is valid.

 X1 and X2 share a terminal with AI1 and AI2.

6 Parameter Description

-  The plus sign means low level is valid, while minus sign means high level is valid.
-  Related monitored parameters: FU-16
-  Description of digital input functions:

1~3: Multistep frequency. Refer to the following table, where “0” indicates invalid, while “1” indicates valid:

X3	X2	X1	Frequency selected	X3	X2	X1	Frequency selected
0	0	0	Reference frequency(common operation)	1	0	0	F4-15 Multistep frequency 4
0	0	1	F4-12 Multistep frequency 1	1	0	1	F4-16 Multistep frequency 5
0	1	0	F4-13 Multistep frequency 2	1	1	0	F4-17 Multistep frequency 6
0	1	1	F4-14 Multistep frequency 3	1	1	1	F4-18 Multistep frequency 7

4: Accel/decel time select 2. If this signal is valid, the current accel/decel time will be the accel/decel time 2, i.e. F1-02 and F1-03

5: External fault input. This signal sends the error or fault information about the peripherals into the inverter, causing the inverter to stop and giving the external fault alarm. This fault can not be reset automatically; it must be reset manually.

6: Fault reset. The rising edge of this signal resets the fault. It has the same function as the key  on the keypad.

7~8: Jog forward/reverse. Refer to 详见 41 页点动功能的描述。

9: Coast stop./ run disabled. If this signal is valid when the inverter is running, the inverter will block the output and the motor will coast to a stop.

10~12: UP/DOWN increase, decrease and clear. Refer to. 详见 48 页 UP/DOWN 的说明。

13: Process PID disabled. This signal invalidates the PID operation. Only when it is invalid and there is no operation mode with a higher priority than PID, can the PID operation begin.

14~16: -wire stop command, internal virtual FWD and REV terminals. Refer to 详见 47 页 FWD/REV 运转模式的描述。

17: Accel/decel disabled. When this signal is valid, the accel/decel process will stop, otherwise the accel/decel process will resume.

18: Run command source switched to terminal/keypad. This signal, in conjunction with F0-02, can switch the command source from one to another, as shown in the following table.

F0-02 setting	State of digital input 18	Command source selected
1: Keypad	Invalid	Keypad
	Valid	Terminal
2~3: Terminal	Invalid	Terminal
	Valid	Keypad
4~5: Communication	Invalid	Communication

	Valid	Keypad
--	-------	--------

19: Reference frequency switched to AI1. When this signal is valid, the frequency setting channel will be forcibly switched to AI1, otherwise the frequency setting channel will be restored

20~21: Multi-PID select 1~2. The combination of multi-PID select 1 and 2 determines which PID reference is selected, as shown in the table below.

Multi-PID select 2	Multi-PID select 1	PID reference selected
0	0	Selected by F7-01
0	1	F7-12 “Multi-PID select 1”
1	0	F7-13 “Multi-PID select 2”
1	1	F7-14 “Multi-PID select 3”

22、23 Wobble frequency injection and wobble state reset. Refer to 59 页纺织摆频功能说明。

F4-05	Digital input terminal anti-jittering time	Default	10ms	Change	×
Setting range	0~2000ms				

This parameter determines the anti-jittering time for the digital input signal. Those signals with their duration less than the anti-jittering time will be ignored.

F4-06	FWD/REV run mode	Default	1	Change	×
Setting range	0: 1-wire mode(start/stop) mode 2(start/stop, direction) 4: 2-wire mode 4 (impulse start/stop、 direction) 6: 3-wire mode 2 (start/stop, direction)	1: 2-wire mode 1(FWD, REV) 3: 2-wire mode 3(start, stop) 5: 3-wire mode 1(FWD, REV, stop)	2: 2-wire mode 2(start/stop, direction) 4: 2-wire mode 4 (impulse start/stop、 direction) 6: 3-wire mode 2 (start/stop, direction)		

Related digital inputs include 14、 15 and 16.

Each FWD/REV mode is illustrated in the following table, where S means “level valid” , while B means “edge valid” .

F4-06	Mode	Logic	Diagram
0	1-wire mode (start/stop)	S: Run switch. When it is valid, the motor runs. Note: The run direction is determined by the direction of the reference frequency.	
1	2-wire mode 1 (FWD, REV)	Invalid Invalid Stop	
		Invalid Valid FWD	
		Valid Invalid REV	
		Valid Valid Stop	
		S2(direction) S1(start/stop) Result	
2	2-wire mode 2 (start/stop, direction)	Invalid Invalid Stop	
		Invalid Valid FWD	
		Valid Invalid Stop	
		Valid Valid REV	
		Invalid Invalid Stop	
3	2-wire mode 3 (start, stop)	B1: Run button(normally-open) B2: Stop button(normally-closed) Note: The run direction is determined by the direction of the reference frequency.	

6 Parameter Description

F4-06	Mode	Logic	Diagram
4	2-wire mode 4 (impulse start/stop, direction)	P1: impulse start/stop signal P2: impulse direction signal Note : The direction is decided by reference frequency	
5	3-wire mode 1 (FWD, REV, stop) Digital input 14 needed	B1: Stop button(normally-closed) B2: FWD button(normally-open) B3: REV button(normally-open)	
6	3-wire mode 2 (Run, direction, stop) Digital input 14 needed	B1: Stop button(normally-closed) B2: Run button(normally-open) S: Direction switch. When it is valid, the motor runs reverse.	

- In 1-wire mode or 2-wire mode 1 and 2 under the terminal control mode, if the stop command comes from other sources and causes the inverter to stop, then the stop command must be given before the run command in order to restart the inverter.
- In 3-wire mode 3 and 3-wire mode, the run button is invalid if the normally-closed stop button is open.
- Even if the run direction has been determined, it is still restricted by direction lock
- If the terminal command doesn't contain the direction information, the run direction will be determined by the polarity of the reference frequency channel.

⚠ DANGER : Danger: When the run signal exists and Fb-11(default value), the inverter will self start.

F4-07	UP/DOWN regulation mode	Default	0	Change	○
Setting range	0: Level type(terminal) 1: Pulse type(terminal)				
F4-08	UP/DOWN speed/step	Default	1.00	Change	○
Setting range	0.01~100.00, Minimum unit: level type 0.01%/s, pulse type 0.01%				
F4-09	UP/DOWN memory select	Default	0	Change	○
Setting range	0: Stored on power loss 1: Cleared on power loss 2: Cleared at stop or on power loss				
F4-10	UP/DOWN upper limit	Default	100.0%	Change	○
Setting range	0.0~100.0%				
F4-11	UP/DOWN lower limit	Default	0.0%	Change	○
Setting range	-100.0~0.0%				

- The UP/DOWN function allows the continuous regulation in the switching mode. The regulated value can be used as the frequency reference or PID reference.

F4-07=0: When the digital input 10 or 11 is valid, FU-15 (UP/DOWN value) increases or decreases at the speed set by F4-08; when the digital inputs 10 and 11 are valid or invalid at the same time, FU-15 remains unchanged.

F4-07=1: When the digital input 10 or 11 is valid, FU-15 increases or decreases a step set by F4-08.

The two types of UP/DOWN regulation mode are shown as the following diagrams:

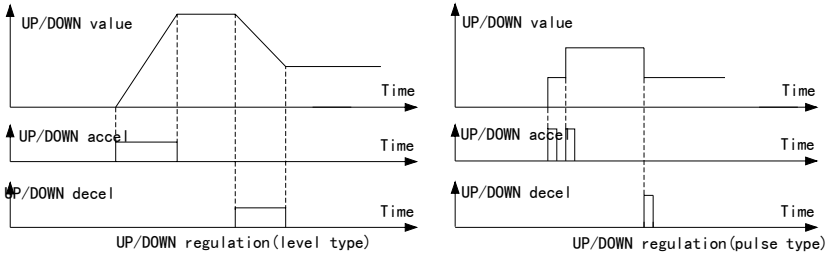

The rising edge of the digital input 12 clears FU-15.

F4-12 ~ F4-18	Multistep frequency 1~7	Default	n.00Hz (n=1~7)	Change	○
Setting range	0.00~650.00Hz Multistep frequencies 1~7's default setting is its respective serial number, for example, the default setting of the multistep frequency 3 is 3.00Hz.				

6.6 F5 Digital output and relay outputs

F5-00	Y1 Digital output terminal	Default	1	Change	×
F5-01	T1 relay output terminal	Default	4	Change	×
Setting range	0: Inverter ready ±1: Inverter running ±2: Frequency reach ±3: Frequency reach detection signal ±4: Fault output ±5: Undervoltage lockout ±6: Fault auto-reset ±7: Restart after momentary power failure ±8: Alarm output ±9: Reverse running ±10: process PID sleeping ±11: Wobble frequency upper/lower limit ±12: Feedback exceeds upper limit alarm ±13: Feedback under lower limit alarm Note: Minus sign means the output is reversed				

Related monitored parameter: FU-16

Detailed description of digital output functions:

0: Inverter ready. The inverter is ready to run.

1: Inverter running. The inverter is in operation.

2: Frequency reach. This signal is valid when the inverter operating frequency falls in the range between reference frequency minus F5-05 and reference frequency plus F5-05. Refer to F5-05.

3: Frequency reach detection signals. Refer to F5-06~F5-07.

6 Parameter Description

4: Fault output. It's valid if any failure occurs.

5: Undervoltage lockout. This signal is valid when DC bus undervoltage causes trip.

6: Fault auto-reset. This signal is valid when fault auto-reset is in process

7: Restart after momentary power failure. This signal is valid if the inverter is waiting for a restart after main circuit undervoltage occurs.

8: Alarm output. This signal is valid when the inverter gives an alarm

9: Reverse running. This signal is valid when the inverter is running reverse.

10: process PID sleeping. The signal is valid when the process PID sleeping [详见56页](#)。

11: Wobble frequency upper/lower limit. When the wobble frequency is operating, if the set center frequency or wobble too high and cause the wobble frequency exceeds upper limit or lower limit, then the signal is valid.

12: Feedback exceeds upper limit alarm. The signal is valid when the PID feedback signal exceeds upper limit alarm time.

13: Feedback under lower limit alarm. The signal is valid when the PID feedback signal under lower limit alarm time.

 Y1 terminal is an open collector output. If its setting is a plus value, it is valid when it is closed; if its setting is a minus value, it is valid when it is open.

F5-02	T1 terminal closing delay	Default	0.000s	Change	<input type="radio"/>
F5-03	T1 terminal opening delay	Default	0.000s	Change	<input type="radio"/>
Setting range	0.000~65.000s				

 T1 terminal output delay is illustrated as follows.

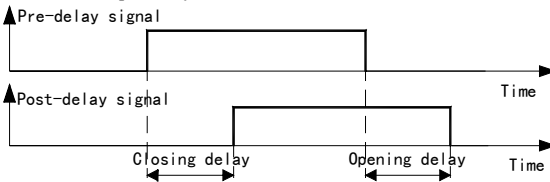

F5-04	Frequency reach detection band	Default	2.50Hz	Change	<input type="radio"/>
Setting range	0.00~650.00Hz				

 The frequency reach signal is sent out when the inverter operating frequency is in the range between reference frequency minus F5-05 and reference frequency plus F5-05, as shown below.

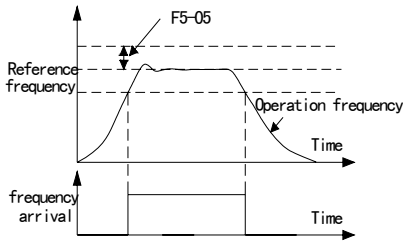

F5-05	Frequency reach detection level	Default	50.00Hz	Change	<input type="radio"/>
F5-06	Frequency reach detection hysteresis	Default	1.00Hz	Change	<input type="radio"/>
Setting range	0.00~650.00Hz				

📖 The digital output 3 or 4(frequency reach detection signal) is valid when the operating frequency is greater than the F5-06. It becomes invalid when the operating frequency is less than “frequency reach detection level-frequency reach detection hysteresis”. Refer to the diagram below.

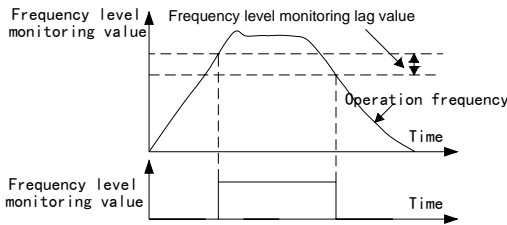

6.7 F6 Analog and pulse frequency terminals

F6-00	A11 Min. input analog value	Default	0	Change	<input type="radio"/>
F6-01	A11 Max. input analog value	Default	100.0%	Change	<input type="radio"/>
Setting range	0.00~100.0%				
F6-02	Reference value/ feedback value in accordance with A11 Min. input analog value	Default	0.00%	Change	<input type="radio"/>
F6-03	Reference value/ feedback value in accordance with A11 Max. input analog value	Default	100.0%	Change	<input type="radio"/>
Setting range	0.00~100.0% Note: reference value is the max. frequency, PID reference/feedback refer to the percentage of PID scalar				
F6-04	A11 input filtering time	Default	0.100s	Change	<input type="radio"/>
Setting range	0.000~10.000s				
F6-05	A12 Min. input analog value	Default	0	Change	<input type="radio"/>
F6-06	A12 Max. input analog value	Default	100.0%	Change	<input type="radio"/>

6 Parameter Description

Setting range	0.00~100.0%				
F6-07	Reference value/ feedback value in accordance with AI2 Min. input analog value	Default	0.00%	Change	○
F6-08	Reference value/ feedback value in accordance with AI2 Max. input analog value	Default	100.0%	Change	○
Setting range	0.00~100.0% Note: reference value is the max. frequency, PID reference/feedback refer to the percentage of PID scalar				
F6-09	AI2 input filtering time	Default	0.100s	Change	○
Setting range	0.000~10.000s				

☞ The max./min. input analog quantity (0.00—100.00%) corresponds with the voltage input of 0V—10V or the current signal of 0mA—20mA. The max./min. input analog quantity is the min. effective signal set or fed back. For example, If AI1 input signal is 0~10V and the actual demand is 2-8V in correspondence with 0~100.00%, F6-00=20.00 (20.00%) and F6-01=80.00 (80.00%). Likewise, if AI1 input is a current signal and actual demand is 4-20mA in correspondence with 0~100.00%, F6-00=20.00 (20.00%) and F6-01=100.00 (100.00%).

☞ Analog inputs AI1 and AI2 can be used to input voltage signals (0V—10V)

☞ AI1 and AI2 have the same electrical properties and parameter settings. Take AI1 channel parameter for example:

Analog Input Example 1: (Default settings of AI1)

When most applications have an analog input voltage of 0~10V/0~20mA in correspondence with the set value/feedback value of 0~100%, the default factory settings can be directly applied.

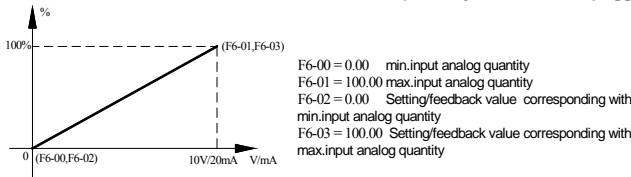

Analog Input Example 2: (Default settings of AI1)

In some applications where the analog input voltage is 2~10V/4~20mA in correspondence with the set value/feedback value (0~100%), the parameter settings will be as follows:

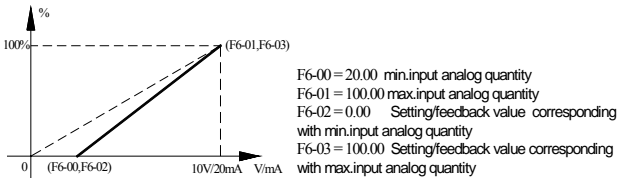

Analog Input Example3: (Application with offset):

In some applications where the analog input voltage is 0~10V/0~20mA in correspondence with the set value/feedback value of 20~100%, the parameter settings will be as follows.

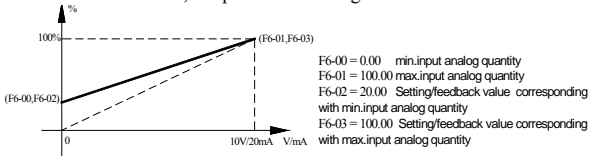

Analog Input Example 4 (Reversed polarity application):

In some applications where the analog input voltage is 0~10V/0~20mA in correspondence with the set value/feedback value of 100~0%, the parameter settings will be as follows

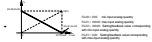

“Filter time”: If the filter time is increased, the response will be slower, but the anti-interference performance will be better; if the filter time is decreased, the response will be faster, but the anti-interference performance will be poorer.

F6-10	AO function	Default	1	Change	○
Setting range	1~11, See the table of analog output functions below.				
F6-11	AO type	Default	0	Change	○
Setting range	0: 0~10V or 0~20mA 1: 2~10V or 4~20mA 2: 5V or 10mA at the center				
F6-12	AO gain	Default	100.0%	Change	○
Setting range	0.0~1000.0%				
F6-13	AO bias	Default	0.00%	Change	○
Setting range	-19.99~99.99%(10V or 20mA=100%)				

Table of analog output functions:

1: Operating frequency (Max. frequency= full-scale value)	6: PID feedback value
2: Reference frequency (Max. frequency =full-scale value)	7: PID reference value
3 : Output current (2 times inverter rated current=full-scale value)	8: AI1
4 : Output voltage (1.5 times inverter rated voltage=full-scale value)	9: AI2
5 : Output capacity (2 times motor rated capacity=full-scale value)	10: UP/DOWN value
	11: DC link voltage (1000V=full-scale value)

Analog output has the following three types:

6 Parameter Description

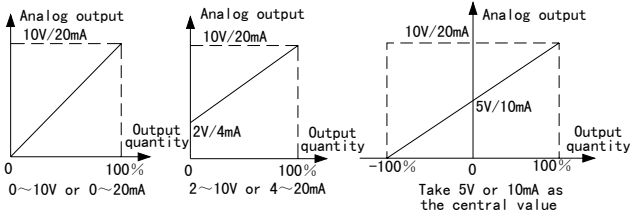

0

Adjusting the gain and bias can change the measuring range and correct the zero point. The calculation formula is: $Y=X \times \text{gain} + \text{bias}$ (X is any item in the table of analog output functions).

6.8 F7 Process PID parameters

F7-00	PID control select	Default	0	Change	×
Setting range	0: PID control disabled 1: PID control enabled(PID output: max. frequency=100%) 2: PID corrects reference frequency (PID output: max. frequency=100%)				

Process PID can be used for the control of process variables such as tension, pressure, flowrate, liquid level and temperature. The proportional(P) element can reduce the error. The integral(I) element can eliminate the static error. The longer the integral time, the weaker the integral action; the shorter the integral time, the stronger the integral action. The differential(D) element can increase the response speed of the control. The structure of process PID is as follows.

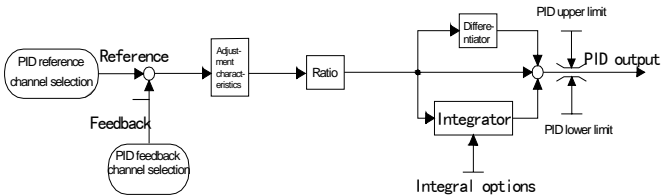



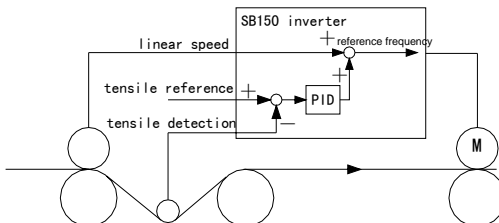

The PID regulation characteristic is determined by the polarity(plus or minus) of F7-06. Integral select is determined by F7-07.



Process PID can also correct the reference frequency prior to accel/dec el slope. The method is adding PID output to the reference frequency. This function makes it convenient to use the inverter for master-slave synchronous control and closed-loop tension control, as shown in the following diagram.



F7-01	PID reference channel	Default	0	Change	×
Setting range	0: F7-04 1: AI1 2: AI2 3: AI1-AI2 4: AI1+AI2 5: UP/DOWN value 7: Keypad POT 8: Communication				
F7-02	feedback channel	Default	1	Change	×
Setting range	1: AI1 2: AI2 3: AI1-AI2 4: AI1+AI2				
F7-03	PID reference scalar	Default	10	Change	○
Setting range	-100.0~100.0				
F7-04	PID digital reference	Default	5.0	Change	○
Setting range	-100.0~100.0				
F7-05	PID adjust characteristic	Default	0	Change	×
Setting range	0: positive 1: negative				

-  PID process adopts normalized input and output, that is, both the input and output range are between -100%~+100%. The input scaling is related to feedback channel, sensor characteristics and analog input setting. The output scaling takes the maximum frequency as 100% for frequency control.
-  There is a filtering section for the PID reference channel and feedback channel, for example, the filtering time for AI1 is F6-04. These filtering sections have influence on the control performance and can be set according to the actual needs.
-  PID adjust characteristic: positive shows that under the stable working status, when the setting value increase, the rotate speed would required to be rising, for example: heating control; negative shows that under the stable working status, when the setting value increase, the rotate speed would required to reducing, for example: cooling control;
-  Related monitor parameters: FU-12、FU-11.

F7-06	Proportional gain	Default	0.20	Change	○
Setting range	0.00~100.00				
F7-07	Integral time	Default	20.00s	Change	○
Setting range	0.00~100.00s, 0shows no				
F7-08	Differential time	Default	0.000s	Change	○
Setting range	0.000~10.000s				

-  F7-06: shows that under the stable working status, when the setting value increase, the rotate speed would required to be rising, for example: heating control;
-  Principle of PID parameter regulation: first raise the proportional gain from a smaller value(e.g. 0.20) until the feedback signal starts oscillating, then lower it by 40~60% to stabilize the feedback signal; reduce the

6 Parameter Description

integral time from a larger value(e.g. 20.00s) until the feedback signal starts oscillating, then raise it by 10~50% to stabilize the feedback signal. Differential action can be introduced if there is a high requirement for overshoot and dynamic error.



F7-09	Sampling period	Default	0.010s	Change	<input type="radio"/>
Setting range	0.001 ~ 10.000s				



It should be generally set to a value five to ten times smaller than the response time of the controlled object.

F7-10	PID upper limit	Default	100.0%	Change	<input type="radio"/>
Setting range	-100.0% ~ 100.0% (Max frequency=100%) Note: It must be greater than F7-11				
F7-11	PID lower limit	Default	0.0%	Change	<input type="radio"/>
Setting range	- 100.0% ~ 100.0% (Max frequency=100%) Note: It must be less than F7-010				



Moderate limitation of PID can reduce overshoot. Excessive limitation should be avoided.

F7-12	Multi-PID setpoint 1	Default	1.0	Change	<input type="radio"/>
F7-13	Multi-PID setpoint 2	Default	2.0	Change	<input type="radio"/>
F7-14	Multi-PID setpoint 3	Default	3.0	Change	<input type="radio"/>
Setting range	- 100.0 ~ 100.0				



Used for multi-PID control. Refer to digital inputs 见 48 页数字输入 20、21 “多段 PID 选择 1~2”。

F7-15	Sleeping Frequency	Default	40.00Hz	Change	<input type="radio"/>
Setting range	0.00 ~ 650.00Hz				
F7-16	Sleeping Latency Time	Default	60.0s	Change	<input type="radio"/>
Setting range	0.0 ~ 3600.0s				
F7-17	Wakeup Deviation Settings	Default	100.00%	Change	<input type="radio"/>
Setting range	0.00 ~ 100.00% Note: 100.00% sleeping function invalid				
F7-18	Wakeup Deviation Settings	Default	0.500s	Change	<input type="radio"/>
Setting range	0.000 ~ 60.000s				



When using process PID, especially at the situation of constant voltage water supply, we can use sleeping function. If the water consumption is small, the system will switch to the sleeping mode and let the digital output “10: process PID sleeping) when the working frequency is lower than the sleeping frequency (F7-15) and the operation time exceeds the sleeping latency time (F7-16). When the actual feedback lower PID setting minus F7-17 and the time exceed F7-18, process PID wakeup and enter normal working status.

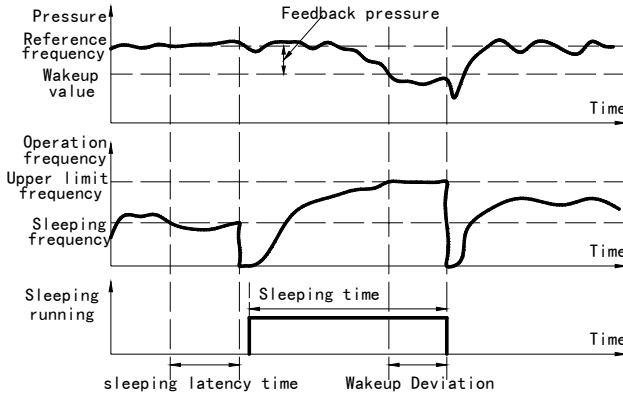

☞ Related digital output function “10: process PID sleeping”, it can be used on other small power pump at the sleeping startup.

F7-19	Feedback exceed upper limit alarm	Default	120%	Change	<input type="radio"/>
Setting range	50.00~200.00%				
F7-20	Feedback exceed upper limit hysteresis	Default	10.0%	Change	<input type="radio"/>
Setting range	0.0~100.00%				
F7-21	Feedback under lower limit alarm	Default	40.0%	Change	<input type="radio"/>
Setting range	0.0~100.00%				
F7-22	Feedback under lower limit hysteresis	Default	10.0%	Change	<input type="radio"/>
Setting range	0.0~50.00%				

☞ Set feedback alarm output, when the feedback signal occur accident, it will give an alarm.

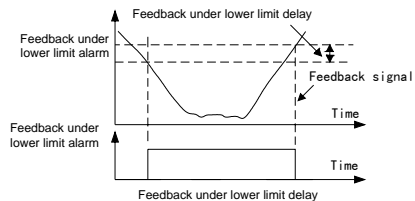
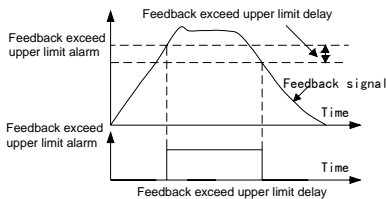

6.9 F9 Wobble frequency

F9-00	Wobble frequency injection mode	Default	0	Change	<input type="checkbox"/>
Setting range	0: Disabled 1: Auto injection 2: Manual injection				

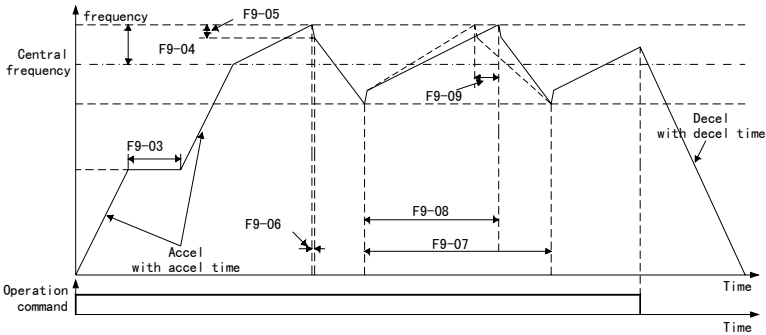

- 📖 When F9-00=1, the inverter first accelerates to F9-02, waits for a period of time (F9-03) (or waits until the digital input 53 becomes valid if F9-00=2), and then reaches the center frequency. After that, it begins the wobble operation according to the settings of F9-04~F9-08 and keeps running until receiving the stop command.
- 📖 F9-00=2: the difference with auto injection is that the end condition of wobble preset status is digital input 22 “wobble injection” valide, while digital input 22 invalid, it returns to wobble preset status, it is unrelated to F9-03.
- 📖 The source of the center frequency is the reference frequency for common operation, multi-speed operation and PLC operation.
- 📖 F9-04 should not set too high. That will cause motor overheating. F9-04 is normally set to 0.5~2Hz.
- 📖 F9-05 is use to overcome the actual speed lag caused by the inertia. It is only used when there is a relatively large inertia of the grooved drum.
- 📖 F9-06 sets the time the sudden jump frequency spends.
- 📖 F9-07 sets the time for a complete wobble cycle.
- 📖 F9-08 sets the time for the rising edge. Actual rising time=wobble period×rising time. Actual falling time=wobble period×(1－rising time).
- 📖 When F9-09 is not equal to zero, the actual rising time will vary randomly within a certain range, while the wobble period remain unchanged. The function of random wobble can prevent the stacking of some high-elasticity fibres when they are wound.
- 📖 F9-10 selects the wobble restart mode.
- 📖 Digital input 23: If F9-00=1, the inverter runs at the preset frequency; if F9-00=2, the wobble frequency is disabled and the inverter runs at the center frequency.
- 📖 Digital output 11: If the center frequency or wobble amplitude is set too high and the wobble frequency goes beyond the upper- or lower-limit frequency, the wobble amplitude will be reduced automatically to make the wobble frequency fall within the range between upper- and lower-limit frequency, as shown below.

6 Parameter Description

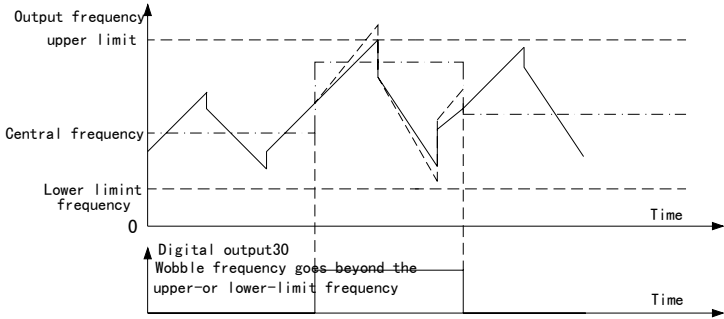

The wobble frequency is only valid in stable operation. If the center frequency changed during the wobble operation, the wobble frequency becomes invalid automatically until the stable operation resumes.

It is recommended to set F2-06 as Zero when use wobble function.

6.10 Fb Protection functions and advanced settings

Fb-00	Motor overload protection level	Default	100.0%	Change	○
Setting range	50.0~150.0%, (motor rated current=100%)				
Fb-01	Motor overload action	Default	2	Change	×
Setting range	0: No action 1: Continue running with an alarm 2: Coast to a stop due to fault				

Fb-00 is used to adjust the motor overload protection curve. Suppose the motor is running at the rated speed and Fb-00=100%, if the motor suddenly runs at 150% of its rated current, then the overload protection function will take effect one minute later, as shown in the following diagrams.

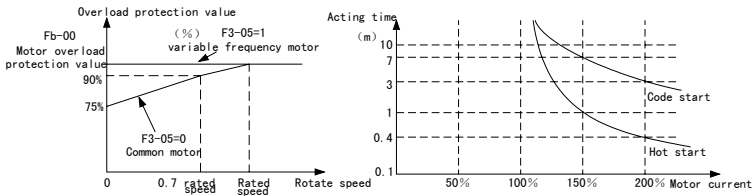

When the motor overload protection takes effect, the motor can continue to run only after it is cooled.

CAUTION: When the motor overload protection takes effect, the motor can continue to run only after it is cooled.

Fb-02	Analog input disconnection action	Default	0	Change	×
Setting range	0: No action 1: A.ACo alarm 2: Run at the frequency set by F0-00, with an A.ACo alarm 3: Coast to a stop, with an E.ACo alarm				

The analog input is considered to be disconnected when the inverter detects that the analog input signal is

lower than the disconnection threshold.

📖 Related parameters: F6-00 and F6-05

Fb-03	phase loss protection	Default	3	Change	×
Setting range	1: Motor coasts to a stop with alarm E.PLI(input phase loss) 2: Motor coasts to a stop with alarm E.Plo(output phase loss) 3: Motor coasts to a stop(input & output phase loss)				

📖 Inverter input phase loss is judged by the DC link voltage ripples it causes. In no-load or slight-load operation, the input phase loss may not be able to be detected. When there is great imbalance among the three input phases or great oscillation with the output, input phase loss will also be detected.

📖 When the inverter has the fault of output phase loss, the motor will run in single phase, which will lead to both a greater current and torque pulsation. Output phase loss protection prevents the motor and its mechanical load being damaged.

📖 When the output frequency or current is very low, the output phase loss protection will be invalid.

Fb-04	overcurrent stall point	Default	110.0%	Change	×
Setting range	0.0~150.0%(0.0 means invalid. Inverter rated current=100%)				
Fb-05	Overvoltage stall point	Default	350V 700V	Change	×
Setting range	200V class: 325~375V, default 350V 400V class: 650~750V, default 700V				

📖 During acceleration (or constant-speed running), the motor stops accelerating(or begins decelerating) when the output current is greater than Fb-04, and restores to its original operating status after the current drops, as shown in the following diagrams (a) and (b).

📖 During deceleration, the motor stops decelerating when the DC bus voltage is greater than Fb-05, and continues decelerating after the DC bus voltage drops to the normal level, as shown in the diagram (c) below.

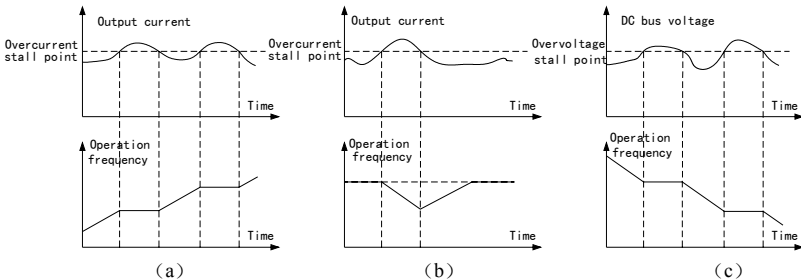

Fb-06	DC link undervoltage action	Default	0	Change	×
Setting range	0: Coast to a stop and report the undervoltage fault(E.dcl) 1: Coast to a stop, and restart				
Fb-07	DC link undervoltage point	Default	200V 400V	Change	×

6 Parameter Description

Setting range	200V class: 185~240V, default 200V 400V class: 300~480V, default 400V
---------------	--

 The detection of momentary power failure is completed by detecting the DC link voltage. When DC link voltage is less than Fb-07:

Fb-06=0: The motor coasts to a stop, and the fault of DC link undervoltage is reported;

Fb-06=1: lockout output, DC busbar voltage decrease become slowly, if the voltage recover, then press F1-04 to restart.

 Fb-06=1 can prevent undervoltage stop caused by momentary power failure for large-inertia loads like fans and centrifuges.

 If undervoltage occurs during running, the motors coasts to a stop and the undervoltage fault (E.dCL) is reported. If undervoltage occurs in standby state, only the alarm of (A.dCL) is given.

Fb-08	Auto reset times	Default	0	Change	×
Setting range	0~10				
Fb-09	Auto reset interval	Default	5.0s	Change	×
Setting range	1.0~30.0s				
Fb-10	Fault output during auto reset	Default	0	Change	×
Setting range	0: No output 1: Output				

 Auto reset function: when a fault occurs during running, the fault is reset automatically according to the settings of Fb-08 and Fb-09, thus avoiding trip due to misoperation, instantaneous power supply overvoltage and external non-repeated impact.

 Auto reset process: when a fault occurs during running, it is reset automatically after a period of time. If the fault disappears, the motor restarts according to the mode set by F1-04; if the fault still exists and the reset times is less than Fb-08, auto reset is continued being retried, otherwise an alarm is reported and the motor stops.

 Fb-08 is cleared in any of the following cases: no fault occurs for continuous ten minutes after the fault reset; fault is manually reset after it is detected; power supply resumes after the momentary power failure.

 Fb-10 selects whether the digital output 5 is valid during auto reset.

 Faults of “power device protection” (E.FoP) and “external fault” (E.EEF) are not reset automatically.

 **DANGER** : Danger: Be extremely careful while using the auto reset function, for it may cause injury to people or damage to equipment.

Fb-11	Power-on auto restart	Default	1	Change	○
Setting range	0: Disabled 1: Enabled				



 When terminal is the command source and F4-06=0、1、2), if the run command is valid after power-on, then **Fb-11** can be used to select whether to start the system immediately.

Fb-12	Built-in braking unit working threshold	Default	340V 680V	Change	○
--------------	--	---------	--------------	--------	---



Setting range	200V class: 310~360V, default 340V 400V class: 620~720V, default 680V
---------------	--

-  Using the braking unit can consume the energy on the braking resistor and make the motor stop quickly. When the DC link voltage exceeds **Fb-12**, the braking unit will begin working automatically.

Fb-13	Carrier frequency	Default	4 kHz,	Change	<input type="radio"/>
Setting range	1.1k~16.0kHz,				
Fb-14	Carrier frequency auto adjustment	Default	1	Change	<input type="radio"/>
Setting range	0: Disabled 1: Enabled				

-  Increasing the carrier frequency can lower the motor noise, harmonic current and the heat generated by the motor, but raise the common-mode current, disturbance and the heat generated by the inverter, and decreasing the carrier frequency will lead to the opposite. Therefore, when a silent run is required, you can moderately raise the carrier frequency. If the carrier frequency is higher than the factory setting, the inverter should be derated by 5% for every increment of 1kHz.
-  Fb-14 can automatically regulate the carrier frequency according to the heat sink temperature, output current and output frequency, preventing the inverter from failing due to overheating. The carrier frequency falls automatically if the heat sink temperature and the low-frequency current are too high.

Fb-15	Jump frequency	Default	0.00Hz	Change	<input type="radio"/>
Setting range	0.00~625.00Hz				
Fb-16	Jumping width	Default	0.00Hz	Change	<input type="radio"/>
Setting range	0.00~20.00Hz				

-  Jump frequency prevents the inverter running at the mechanical resonant points.
-  During acceleration or deceleration, the inverter can run through the jump frequency smoothly(i.e. jump frequency becomes invalid), but can not keep steady-state operation within the jumping width.

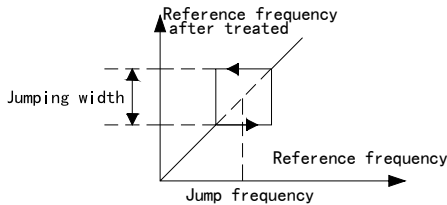



6.11 FC: Keypad operation and display settings

FC-00	Display parameter select	Default	0	Change	<input type="radio"/>
Setting range	0: All menus 1: User-selected parameters				
FC-01	Monitored parameter 1 (in run and standby)	Default	1	Change	<input type="radio"/>

6 Parameter Description

FC-02	Monitored parameter 2 (in run and standby)	Default	-1	Change	○
FC-03	Monitored parameter 3 (in run and standby)	Default	-1	Change	○
FC-04	Monitored parameter 4 (in run and standby)	Default	-1	Change	○
FC-05	Monitored parameter 1 (in run)	Default	0	Change	○
FC-06	Monitored parameter 2 (in run)	Default	2	Change	○
FC-07	Monitored parameter 3 (in run)	Default	4	Change	○
Setting range	-1~17, -1 indicates null and 0~17 represent FU-00~FU-17 Note: FC-00 range: 0~17				

 FC-00=1: Only display parameters different from default setting in order to adjust and maintain conveniently.

 select(from the FU menu) the parameters to be monitored in both running and standby states.





 select(from the FU menu) the parameters to be monitored only in running status

FC-08	Speed display coefficient	Default	1.000	Change	○
Setting range	0.001~10.000 Note: Only used for speed conversion, without any effect on actual speed and motor control FU-05= $120 \times \text{operating frequency} \div \text{motor pole number} \times \text{FC-08}$ FU-06= $1120 \times \text{running frequency} \div \text{motor pole number} \times \text{FC-08}$				
FC-09	Line speed display coefficient	Default	0.01	Change	○
Setting range	0.01~100.00 Note: Only used for speed conversion, without any effect on actual speed and motor control FU-09= operating frequency \times FC-09 FU-10= running frequency \times FC-09				



6.12 FF Communication parameters

FF-00	Data format	Default	0	Change	×
Setting range	0:8,N,1 (1 start bit, 8 data bits, no parity check, 1 stop bit) 1:8,E,1 (1start bit, 8 data bits, even check, 1 stop bit) 2:8,O,1 (1 start bit, 8 data bits, odd check, 1 stop bit) 3:8,N,2 (1 start bit, 8 data bits, no parity check, 2 stop bits)				
FF-01	Baud rate	Default	3	Change	×
Setting range	0: 1200bps 1: 2400bps 2: 4800bps 3: 9600bps 4: 19200bps				
FF-02	Local address	Default	1	Change	×
Setting range	1~248, 248 as master				
FF-03	Overtime detection time	Default	10.0s	Change	○
Setting range	0.1~600.0s				
FF-04	Overtime action	Default	0	Change	×
Setting range	No action 1: Alarm 2: Alarm and run according to F0-00 3: Alarm and coast to a stop				
FF-05	Master to slave	Default	0	Change	×

Setting range	0: frequency reference value		1: PID reference value			
FF-06	Slave reference scale factor		Default	1.00	Change	○
Setting range	0.01-100.00					

-  SB150 inverter's RS485 Modbus protocol comprises three layers: Physical layer, Data Link layer and Application layer. The former two layers employ the RS485-based Modbus protocol. The application layer controls the run/stop of the inverter and the parameter reading and writing and so on.
-  Modbus is a master-slave protocol. The communication between the master and slave falls into two types: master requests, slave responds; master broadcasts, slave doesn't respond. The master polls the slaves. Any slave can't send messages without receiving the command from the master. The master may resend the command when the communication is not correct. If the master doesn't get a response within given time, the slave polled is considered to be lost. The slave sends a piece of error information to the master if it can not implement a message.
-  Communication only changes RAM values. If a parameter in RAM is to be written into EEPROM, the communication variable "EEP write command"(Modbus address is 3209H) needs to be changed to 1 by communication.
-  SB150 inverter can do communication as master, set local address FF-02=248. When a group of inverter are used for multimachine synchronism working status, set one of them as master and send frequency reference value or PID reference value to others, and then it can achieve synchronism ratio control. Master would send operation procedure in broadcast communication ways, when the slave receive the command, the reference value of the master can be confirmed by the slave scale factor.
-  Method of addressing the inverter parameters: among the 16 bits of the Modbus parameter address, the upper 8 bits represent the group number of a parameter, and the lower 8 bits represent the serial number of the same parameter in the group. For example, the address of the parameter F4-17 is 0511H. The group number is 50(32H) for communication variables(control word, status word, etc.).

Menu code	Parameter group No.	Menu code	Parameter group No.	Menu code	Parameter group No.	Menu code	Parameter group No.
F0	0 (00H)	F4	4 (04H)	F9	8 (08H)	Fn	12 (0CH)
F1	1 (01H)	F5	5 (05H)	Fb	9 (09H)	FP	13 (0DH)
F2	2 (02H)	F6	6 (06H)	FC	10 (0AH)	FU	14 (0EH)
F3	3 (03H)	F7	7 (07H)	FF	11 (0BH)	—	—

-  The data transmitted in communication are 16-bit integers. The minimum unit can be seen from the position of the radix point of the parameter. For example, the minimum unit of F0-00 is 0.01Hz, therefore, the data 5000 transmitted in communication represents 50.00Hz.
-  Table of communication command variables

Name	Modbus address	Change	Description
Main control	3200H	○	Bit 0: ON/OFF1(run on rising edge. 0: stop)

6 Parameter Description

Name	Modbus address	Change	Description
word			Bit 1: OFF2(0: coast stop), digital input 9 priority Bit 2~3: Reserved Bit 4: Accel/decel enabled(0: accel/decel disabled), digital input 17 priority Bit 5~6: Reserved Bit 7: Fault reset(on rising edge), digital input 6 priority Bit 8: Jog forward, digital input 7 priority Bit 9: Jog reverse, digital input 8 priority 8 Bit 10: Reserved Bit 11: Reference reversion(1: reference frequency reversed, 0: not reversed) Bit 12: Reserved Bit 13: UP/DOWN increase, digital input 10 priority Bit 14: UP/DOWN decrease, digital input 11 priority Bit 15: Process PID disabled, digital input 13 priority
Communication reference frequency	3201H	○	Non-negatives(unit: 0.01Hz)
Communication PID reference	3202H	○	Range: - 100.00~100.00%
EEPROM write-in	3209H	○	When “1” is written to this address, the parameters in the inverter RAM will be written in EEPROM.

☞ Table of communication status variables

Name	Modbus address	Name	Modbus address
Main status word	3210H	△	Bit 0: Ready(constant 1) Bit 1: Ready for run Bit 2: Running Bit 3: Fault Bit 4: OFF2 valid(0: valid) Bit 5: OFF3 stopping(0: valid) Bit 6: Charging contactor open Bit 7: Alarm Bit 8~9: Reserved Bit 10: Frequency reach detection signal 1 Bit11~13: Reserved Bit 14: Running forward Bit 15: Reserved
Operating frequency	3211H	△	Non-negatives(unit: 0.01Hz)
Load current percentage	3212H	△	Unit: 0.1%
PID feedback	3213H	△	Unit: 0.01%
Reference frequency	3214H	△	Non-negatives(unit: 0.01Hz)
Output current	3215H	△	Unit:0.1A
PID Reference	3216H	△	Unit:0.01%
Output voltage	3217H	△	Unit:0.1V
DC link voltage	3218H	△	Unit:0.1V
Fault code	3219H	△	详见 69 页故障内容及对策表 Refer to Section
Alarm word	321AH	△	详见 71 页报警内容及对策表 Refer to Section

☞ SB150 inverter supports the communication on a Modbus network using RTU(Remote Terminal Unit) mode.

The functions it supports include: Function 3(read multiple parameters, with max. word number of 30), Function 16(write multiple parameters, with max. word number of 10), Function 6(mask write) and

Function 8(read-back test). Among them, Functions 6 and 16 support broadcast(broadcast message address is 0). In RTU mode, both the starting and ending of the message frame are marked by an interval of at least 3.5 character times(but 2ms for baud rates of 19200bit/s and 38400bit/s). A typical RTU message frame is shown below.

Slave address (1 byte)	Modbus function code (1 byte)	Data (multiple bytes)	CRC16 (2 bytes)
---------------------------	----------------------------------	--------------------------	--------------------

📖 Function 3: read multiple parameters. Word number read ranges from 1 to 30. Refer to the following example for its message format.

Example: read the main status word, operating frequency and arithmetic unit 1 output(three words with their addresses beginning with 3210H) from the #1 slave.

Query from master:	Slave address	01H	Response from slave:	Slave address	01H
	Modbus function code	03H		Modbus function code	03H
	Start address(MSB)	32H		Byte number returned	06H
	Start address(LSB)	10H		MSB of 3210H	44H
	Word number read(MSB)	00H		LSB of 3210H	37H
	Word number read(LSB)	03H		MSB of 3211H	13H
	CRC(MSB)	0AH		LSB of 3211H	88H
	CRC(LSB)	B6H		MSB of 3212H	00H
				LSB of 3212H	00H
				CRC(LSB)	5FH
		CRC(MSB)	5BH		

📖 Function 6: write single parameter. Write works is 1, the slave return details is in accordance with the master.

Example: to make the #1 forward run at 50.00Hz, 003FH You can rewrite the addressee from 3200H to 003EH: Refer to the following table for the message format:

Query from master:	Slave address	01H	Response from slave:	Slave address	01H
	Modbus function code	06H		Modbus function code	06H
	Start address(MSB)	32H		Start address(MSB)	32H
	Start address(LSB)	00H		Start address(LSB)	00H
	Word number written(MSB)	00H		Word number written(MSB)	00H
	Word number written(LSB)	3FH		Word number written(LSB)	3FH
	CRC(LSB)	C7H		CRC(LSB)	C7H
	CRC(MSB)	62H		CRC(MSB)	62H

📖 Function 16: write multiple parameters. Word number written ranges from 1 to 10. Refer to the following example for its message format.

Example: to make the #1 slave stop(forward run at 50.00Hz), you can rewrite the two words with their addresses beginning with 3200H into 003EH and 1388H.

H	Slave address	01H
---	---------------	-----

6 Parameter Description

	Modbus function code	10H		Response from slave:	Slave address	01H
	Start address(MSB)	32H			Modbus function code	10H
	Start address(LSB)	00H			Start address(MSB)	32H
	Word number written(MSB)	00H			Start address(LSB)	00H
	Word number written(LSB)	02H			Word number written(MSB)	00H
	Byte number written	04H			Word number written(LSB)	02H
	MSB of 1st data	00H			CRC(LSB)	4FH
	LSB of 1st data	3FH			CRC(MSB)	70H
	MSB of 2nd data	13H				
	LSB of 2nd data	88H				
CRC(LSB)	83H					
CRC(MSB)	94H					

Example: to make the #1 slave stop(forward run at 50.00Hz), you can rewrite the two words with their addresses beginning with 3200H into 003EH and 1388H.

Query from master:	Slave address	01H	Response from slave:	Slave address	01H
	Modbus function code	10H		Modbus function code	10H
	Start address(MSB)	32H		Start address(MSB)	32H
	Start address(LSB)	00H		Start address(LSB)	00H
	Word number written(MSB)	00H		Word number written(MSB)	00H
	Word number written(LSB)	02H		Word number written(LSB)	02H
	Byte number written	04H		CRC(LSB)	4FH
	MSB of 1st data	00H		CRC(MSB)	70H
	LSB of 1st data	3EH			
	MSB of 2nd data	13H			
	LSB of 2nd data	88H			
	CRC(LSB)	D2H			
	CRC(MSB)	54H			

6.13 FP: Fault history

见 33 页。

6.14 FU: Data monitoring

见 35 页。

7 Troubleshooting

7.1 Faults and remedies



Fault code	Fault type	Possible causes	Remedies
<i>E.ocb</i> E.ocb (1)	Overcurrent at start	Inter-phase or grounding short-circuit inside the motor or between wirings	Check the motor and wiring
		Inverting module failed	Call us
		Voltage overhigh at start	Check the setting of “torque boost”
<i>E.ocA</i> E.ocA (2)	Overcurrent during acceleration	Accel time too short	Increase the accel time
		V/F curve improper	Regulate V/F curve or the setting of “torque boost”
		Running motor restarts	Set the start mode as “smooth start” Restart the motor after it stops completely
		Low power grid voltage	Check the input power
		Inverter capacity too small	Use an inverter with larger capacity
<i>E.occ</i> E.occ (3)	Overcurrent during deceleration	Decel time too short	Increase the decel time
		There is potential energy load or inertial torque of the load is large	Install an external dynamic braking unit
		Inverter capacity too small	Use an inverter with larger capacity
<i>E.ocn</i> E.ocn (4)	Overcurrent during constant-speed operation	Sudden change of load	Reduce the sudden change of the load
		load error	Check the load
		Low power grid voltage	Check the input power
		Inverter capacity too small	Use an inverter with larger capacity
<i>E.ouA</i> E.ouA (5)	Overvoltage during acceleration	Input voltage abnormal	Check the input power
		Running motor restarts	Set the start mode as “smooth start” Restart the motor after it stops completely
<i>E.oud</i> E.oud (6)	Overvoltage during deceleration	Decel time too short	Increase the decel time
		There is potential energy load or inertial torque of the load is large	Install an external dynamic braking unit
<i>E.oun</i> E.oun (7)	Overvoltage during constant-speed operation	Input voltage abnormal	Check the input power
		Accel/decels time too short	Increase the accel/decels time
		Input voltage changes irregularly	Install an input reactor
<i>E.ouE</i> E.ouE (8)	Overvoltage in standby state	Input voltage overhigh	Check the input power
		Error of DC bus voltage test circuit	Call us
<i>E.dcl</i> E.dcl (9)	Undervoltage during running	Input voltage abnormal or power loss during running	Check input power and wiring
		There is heavy-load impact	Check the load
		Charging contactor failed	Check and replace it

Fault code	Fault type	Possible causes	Remedies
		Input phase loss	Input the input power and wiring
<i>E.PLI</i> E.PLI (10)	Input phase loss	Input power phase loss	Check the wiring
		Three input phases imbalanced	Check input voltage
		Serious oscillation of output	Adjust parameters to eliminate the oscillation
<i>E.PLo</i> E.PLo (11)	Output phase loss	Loss of output (U, V or W)	Check the output wiring Check the motor and cables
<i>E.FoP</i> E.FoP (12)	Power device protection	Output has interphase short-circuit or grounding short-circuit	Rewire
		Wiring of or components on the control board loose	Check and rewire
		Wiring of the motor or inverter too long	Add output reactor or filter
		Serious interference or failure of inverter	Call us
<i>E.oHI</i> E.oHI (13)	Inverter overheating	Ambient temperature overhigh	Lower the ambient temperature
		Air path blocked or the fan failed	Clean air path or replace the fan
		Load too heavy	Check the load or select an high-capacity inverter
<i>E.EEF</i> E.EEF (16)	External fault	External fault terminal closed	Deal with the external fault
<i>E.CFE</i> E.CFE (17)	Communication overtime	Improper setting of communication parameters	Check the settings of FF menu
		Serious communication interference	Check the wiring and grounding of the communication circuit
		PC does not work	Check PC and wiring
<i>E.oLI</i> E.oLI (14)	Inverter overload	Load too heavy	Check the load or select an high-capacity inverter
		Inverter temperature too high	Check the fan, air path and ambient temperature
		Accel time too short	Increase the accel time
		Carrier frequency too high	Lower the carrier frequency or select an inverter with a higher capacity
		Running motor restarted	Set the restart mode as “smooth restart” or “restart after motor stops”
		Input voltage too low	Check the input voltage
<i>E.oLL</i> E.oLL (15)	Motor overload	V/F curve improper	Correctly set the V/F curve and torque boost level
		The common motor runs with heavy load at low speed for a long time	Install a separate cooling fan or select a motor designed for inverter
		Improper setting of nameplate parameters or overload protection	Correctly set the V/F curve and torque boost level

7 Troubleshooting

Fault code	Fault type	Possible causes	Remedies
		Motor stalls or load changes suddenly and greatly	Correctly set F3-02、F3-05、Fb-00
		V/F curve improper	Check the load
<i>E.c c F</i> E.c c F (18)	Current test error	Loose wiring or components inside the inverter	Check and rewire
		failed current sensor or circuit error	Call us
<i>E.A c o</i> E.A c o (19)	Analog input disconnection	Wires broken or peripheral devices failed	Check external wires and peripheral devices
<i>E.r H o</i> E.r H o (20)	Thermal resistor open	Thermal resistor disconnected	Check the connection of thermal resistor or call us
<i>E. I o 1</i> E.I o 1 (21)	Reserved	—	—
<i>E. I o 2</i> E.I o 2 (22)	Reserved	—	—

7.2 Alarms and remedies

Alarm code	Alarm name	Description	Remedies	Alarm word Bit
<i>A.oLL</i> A.oLL	Motor overload	Motor thermal model detects the motor temperature rise is overhigh	Refer to above table	Bit 0
<i>A.A c o</i> A.A c o	Analog input disconnection	Analog input signal is lower than the drop threshold	Refer to above table	Bit 1
<i>A.C F E</i> A.C F E	Communication overtime	—	Refer to above table	Bit 2
<i>A.E E P</i> A.E E P	Parameter saving failed	—	Press  to clear Turn power off and retry. If the alarm appears again, call us for help.	Bit 3
<i>A.d c L</i> A.d c L	DC link undervoltage	DC link voltage is lower than the threshold	It is normal for this alarm information to be displayed when the power is off	Bit 4
<i>A.P c E</i> A.P c E	Parameter check error	Improper parameter setting	Correct parameter setting or restore factory setting. Press  to clear	Bit 5

7.3 Operation faults and remedies

Fault	Description	Possible causes	Remedies
No key-press response	One key or all keys have no response to key pressing	Poor contact of the keypad connecting wire	Check the connecting wire or call us
		Key(s) damaged	Replace the keypad
Parameter correction failed	Parameters cannot be modified	The parameters are read-only ones	Read-only parameters are unchangeable
	Parameters cannot be modified in running state	Some parameters are unchangeable during running	Modify them in standby state
Unexpected stop during running	Inverter stops automatically without receiving stop command, and the run LED is off	There is fault	Troubleshoot and reset it
		Run command channel switches over	Check the operation and run command channel status
	Inverter stops automatically without receiving stop command, and the run LED is on	Waiting for the fault auto reset	Check auto reset setting
		Reference frequency is zero	Check reference frequency
		Output frequency is too low under PID control	Check the PID reference and feedback
Waiting for the restart after momentary power failure	—		
Inverter start failed	After receiving start command, inverter fails to start, and the run LED is off	Digital input 9 “coast stop / inverter run disabled” is valid	Check terminal coast stop / inverter run disabled
		The stop key is not closed under 3-wire 1, 3-wire 2 or 2-wire 3 control mode	Check the stop key and its connection
		Run command channel error	Change the run command channel
		Inverter error	Troubleshoot

8 Maintenance and After-sale Service

**DANGER**

- 1. Only professionally trained persons can disassemble and repair the inverter and replace its parts.**
- 2. Make sure the power supply of the inverter is cut off, the high-voltage indicator goes out and the voltage between DC+ and DC- is less than 36V before checking and repairing the inverter, otherwise there may be a risk of electric shock.**
- 3. Do not leave any metal pieces such as screws and washers in the inverter. That many destroy the inverter or cause fire.**
- 4. Reset related parameters after replacing the control board, otherwise the inverter may be destroyed.**

8.1 Daily maintenance

Due to factors of dust, humidity, vibration, aging, etc., faults would occur over time. It is necessary to check the inverter and its working environment regularly in order to extend the lifespan of the inverter.

Check points:

1. If the working environment of the inverter meets the requirement.
2. If the operating parameters of the inverter are set within the specified ranges.
3. If there is any unusual vibration or noise.
4. If there is any unusual odor.
5. If the fans run normally.
6. If the input voltage is within the specified range and voltages of various phases are balanced.

The periodical maintenance should be performed once every three or six months according to the service conditions. Check points:

1. If the screws of control terminals are loose.
2. If the main circuit terminals have a poor contact and the copperplate connections have traces of overheating.
3. If the power and control cables are damaged.
4. If the insulated binding band for the cold-pressed terminals of the power cables comes off.
5. Remove dust on PCBs and wind path thoroughly. It's better to use a vacuum cleaner.
6. When leaving the inverter unused for a long term, check it for functioning once every two years by supplying it with electricity for at least five hours with the motor disconnected. While supplying the epower, use a voltage regulator to raise the voltage gradually to the rated value.

8.2 Replacement of parts

The inverter wearing parts primarily include the electrolytic capacitor (used for wave filtration) and the cooling fan. The service life and the service environment are closely related to maintenance conditions. The user can decide whether to change the wearing parts according to the operating time.

◆ Cooling fan

Causes of damage: wear of bearings; aging of blades(average life is 30 to 40 thousand hours).

Judging criterion: crack in blades, etc.; unusual vibration at the start.

Caution:

1. While replacing the fan, use the fan model designated by the factory(with identical rated voltage, current, speed and air volume).
2. While installing the fan, be careful that the direction marked on the fan must conform to direction in which the fan supplies wind.
3. Do not forget to install the fan guard.

◆ Electrolytic capacitor

Causes of damage: high ambient temperature; frequent and sudden load change which leads to high pulsating current; aging of electrolyte.

Judging criterion: protrusion of safety valve; measurement of static capacitance; measurement of insulation resistance.

It is recommended to replace the bus electrolytic capacitor once every four or five years.

8.3 Storage of the inverter

- ◆ Avoid storing the inverter in a place with high-temperature, humidity, dust and metal powder.
- ◆ Leaving the inverter unused for a long period would lead to aging of the electrolytic capacitors. So the inverter must be supplied with electricity once every two years for at least five hours, and the input voltage raised gradually through a regulator to the rated value.

8.4 After-sale service

The warranty period is one year from the purchase date. However, the repair cost should be born by the user for the following damages even within this term.

1. Damage caused by operation not in accordance with the user's manual.
2. Damage caused by unauthorized repairs or modifications.
3. Damage caused by using the inverter beyond the standard specifications.
4. Damage caused by falling or an accident during transportation after the purchase.
5. Damage cause by fire, flood, abnormal voltage, lightning strike, etc.

In the event of any abnormality arising in operation, check and adjust the inverter as per the user's manual. In case any fault occurs, promptly contact the supplier, the local electrical engineering agent of Hope-Senlan Technologies Corporation or our headquarters. We will rectify any fault for free that arises from manufacturing

and design within the warranty period. For a rectification beyond the warranty period, we will charge the user as required at a reasonable rate.