

**LYE** DUCTILE IRON

# HIGH PERFORMANCE “AEROKINETIC” AIR VALVE

MODEL: **LYE** 358



A High Performance Air Valve that meets all application and installation parameters regardless of piping material.

The “Aerokinetic” Air Valve is ideal for the release of high volumes of air in piping systems and has minimum moving parts thus ensuring long-term reliability.



The Brand Of Reliability

**LYE MANUFACTURING SDN. BHD.** (32836-H)

Manufacturer of Valves, Hydrants, Joints, Fittings & Manhole Covers.





**LYE DUCTILE IRON**

# HIGH PERFORMANCE “AEROKINETIC” AIR VALVE

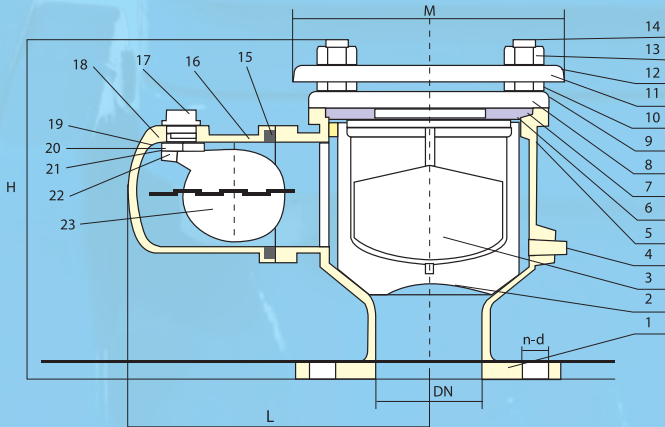

Overall Dimensions for **LYE** “Aerokinetic” Air Valve  
(Model: **LYE 358**) DN50 to DN150

Specification (DN)	L (mm)	M (mm)	H (mm)
50	228	206	321
65	228	206	321
80	228	206	321
100	239	280	410
150	239	280	410

## Main Features

- High discharge and inflow capacities throughout the full pressure range.
- All valves coated with fusion bonded epoxy (FBE).
- Unique design prevents premature seating of float.
- Working pressure: 10/16bar.
- Shell test pressure: 15/24bar.
- Seat test pressure: 11/17.6bar.
- Working temperature: 0.6°C ~ 52°C.

## Materials for Main Parts

No	Description	Material	Specification
1	Main Body	Ductile Iron	BS EN 1563 500/7
2	Float Guides	ABS	ISO 2580
3	Main Float	ABS	ISO 2580
4	Drain Plug	Stainless Steel	BS 970 304S15
5	Supporting Plate	ABS	ISO 2580
6	Seal Ring	EPDM	MS 672:99 / BS EN 681
7	Seat Ring	ABS	ISO 2580
8	Cover	Ductile Iron	BS EN 1563 500/7
9	Washer	Galvanized Steel	BS 3692
10	Nut	Galvanized Steel	BS 3692
11	Cowl	Ductile Iron	BS2789 420-12
12	Washer	Galvanized Steel	BS4190
13	Nut	Galvanized Steel	BS4190
14	Bolt	Galvanized Steel	BS4190
15	O-ring	EPDM	MS 672:99 / BS EN 681
16	Side Body	Ductile Iron	BS EN 1563 500/7
17	Orifice Cover	High Tensile Nylon	-
18	Gasket	EPDM	MS 672:99 / BS EN 681
19	Orifice Bracket	High Tensile Nylon	-
20	Screw	Stainless Steel	BS 970 304S15
21	Sealing Face	EPDM	MS 672:99 / BS EN 681
22	Hinge Pin	Stainless Steel	BS 970 304S15
23	Side Float	ABS	ISO 2580

Please Note: Technical data provided is indicative only and may be subject to change without notice



**LYE MANUFACTURING SDN. BHD. (32836-H)**  
**Manufacturer of Valves, Hydrants, Joints, Fittings & Manhole Covers.**  
 Lot 1844, Jalan KPB 8, Kampung Baru Balakong, 43300 Kajang, Selangor Darul Ehsan, Malaysia.  
**FACTORY:** Tel : 603 - 8961 1623, Fax : 603 - 8961 1092  
**SALES:** Tel : 603 - 6140 3131 (Hunting Line) Fax : 603 - 6140 5858  
**WEBSITE:** www.lye.com.my  
**EMAIL:** enquiry@lye.com.my

