

Orientalmotor

Brushless Motor and Driver Package

BMU Series

Easy Speed Control with Spin and Push



30 W Full Size

Lineup Added

Hypoid Right-Angle
Hollow Shaft Gear and
Various Gears

Gearheads Supporting
Food Machinery Grease H1

Easy Speed Control with Spin and Push

A settings dial designed for easy speed control.

Once the motor and the driver are connected, all you do for this simple wiring is turn on the switch.

The new brushless motor NexBL is a compact, high-power, and high-efficiency motor.

For the **BMU** Series that focuses on user-friendly features and affordable prices, we also provide various gearheads, including hypoid right-angle hollow shaft gearheads.*

Wider applications.

* Some gearheads support food machinery grease H1



- ① Spin and push. Easy speed control.
- ② Easy wiring. Quick start.
- ③ Opening the panel reveals extensive functions.
- ④ New Brushless Motor NexBL.



NexBL is Oriental Motor's new brushless motor, having redesigned the entire structure for maximizing the performance required for motors. NexBL is more compact with higher output and efficiency than ever before.



Brushless Motor and Driver Package **BMU** Series

BMU Series



Cable Type



Connector Type

Connects the motor and the driver directly. Delivers smart wiring and dust-resistant and watertight performance (with a Degree of Protection IP66).



Video Library





You can watch videos for product features, installation, maintenance, and more!
www.orientalmotor.com.sg

Introduction of the NEW Lineup → Page 4

Introduction of the NEW Lineup

4 Types of Selectable Gearheads

The connector types of the **BMU** Series suit more variations of gears. You can choose to meet your usage or method of installation. For types and features of each gearhead, see pages 10 and 11.

 <p>IP66</p>	 <p>IP44</p>	 <p>IP66</p>	 <p>IP66</p>
<p>Hypoid Right-Angle Hollow Shaft JH Gear 60 W, 120 W, 200 W, 400 W</p>	<p>Legged Gearhead JB Gear 200 W, 400 W</p>	<p>Parallel Shaft Gearhead GFV Gear 30 W, 60 W, 120 W, 200 W, 400 W</p>	<p>Parallel Shaft Gearhead JV Gear 200 W, 400 W</p>
<p>Space saving Cost saving Stainless steel shaft</p>	<p>Legged all-in-one gear High gear ratio 1/1200</p>	<p>Long life Rated life 10,000 hours Stainless steel shaft</p>	<p>High gear ratio 1/450 Stainless steel shaft</p>

● Compact, Lightweight, High Power, Energy/Space-Saving

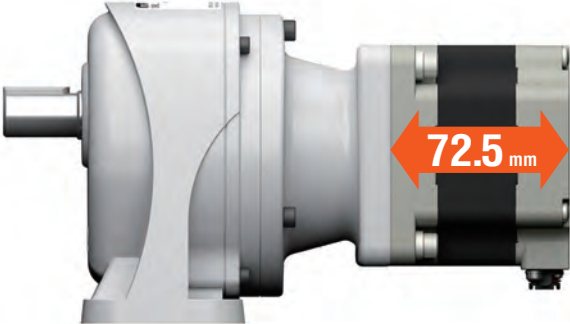

Comparison with general 400 W motors

Motor length only	1/3
Motor and Driver Efficiency	87%

Compact, Lightweight

High Power

Energy/Space-Saving

* For the legged gearhead **JB** gear with 1/5 gear 400 W ratio.

Supports Food Machinery Grease H1 (Connector type only)

Food machinery grease H1 is used for gear lubrication.

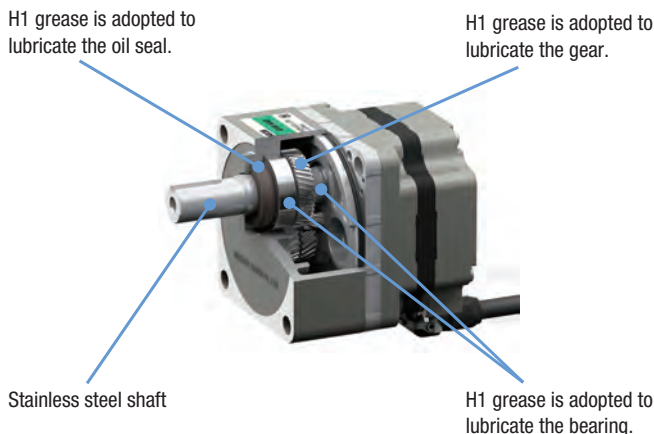

- **What is food machinery Grease H1?**
It is a grease categorized by the NSF as "a lubricant with incidental food contact for use in and around food processing areas" categorized by the NSF.
What is the NSF (NSF International)?
It is an international third-party certifier headquartered in the U.S. which provides global services regarding public health and the environment, including standard development, product certification, audits, education, and risk management.
- **The rated life of the gearhead is 5,000 hours**

Features of Brushless Motor

Because our brushless motor do not have brushes, which is the DC motor demerit, they produce less noise and are maintenance-free. The use of permanent magnets allows for compact, high output, and highly efficient motors.

Wide Speed Control Range

The brushless motor has a broader speed control range compared to AC speed control motors and inverters. They are ideal for applications that require a constant torque for all speeds, low to high.

Product Group	Speed Control Range*	Speed Ratio
Brushless Motor (BMU Series)	80~4000 r/min	1:50
Inverter Control Three-Phase Induction Motor	200~2400 r/min	1:12
AC Speed Control Motor	50Hz: 90~1400 r/min	1:15
	60Hz: 90~1600 r/min	1:17

*The speed control range varies depending on the model.

Stable Speed Control

The brushless motors always monitor feedback signals from the motor and compare them with the set speed to adjust the applied voltage. For this reason, even if the load changes, stable rotation is performed from low speed to high speed.

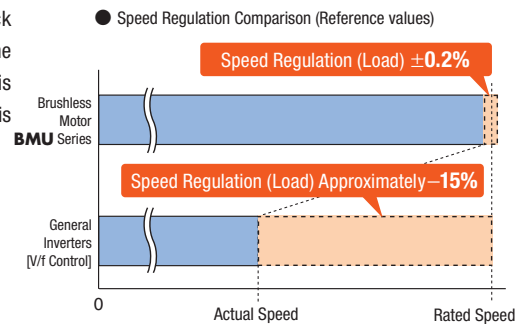

The table on the right shows the speed regulation (load) for each model. It shows how much the rotational speed varies by changing the load between 0 to rated torques.

Model	Speed Regulation with Varying Loads	Condition
		0 ~ rated torque at rated speed
BMU Series	$\pm 0.2\%$	
BLE2 Series	$\pm 0.2\%$	
BLE Series	$\pm 0.5\%$	
BXII Series	$\pm 0.05\%$	
BLH Series	$\pm 0.5\%$	

Thin, Lightweight and High Power

The brushless motors use permanent magnets so that they are thin and lightweight but yet have high power. These contribute to the downsizing of equipment.

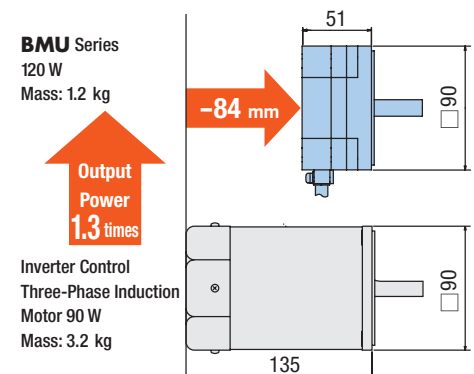

Contributes to Energy Savings

The brushless motors use permanent magnets in the rotor, reducing secondary loss and power consumption. This contributes to energy savings with the equipment.

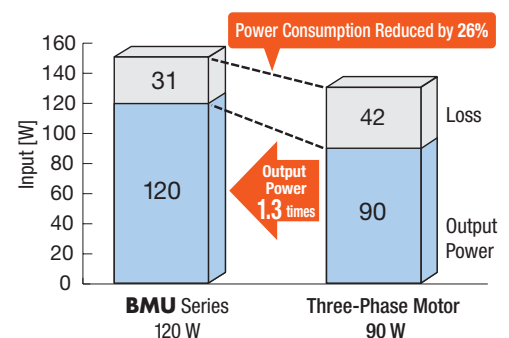

Main Features of BMU Series

- Easy speed control with "Spin and Push" of the setting dial.
- Easy wiring by connecting the motor and the driver and turning on the switch.
- Employs new compact, high output, highly efficient brushless motors.
- Lineup cable and connector types.
- The connector type delivers dust-resistant and watertight performance with a Degree of Protection IP66 specification.
- Delivers the highest level of speed control at reasonable prices.

- 2 motor types are selectable by the connection method.

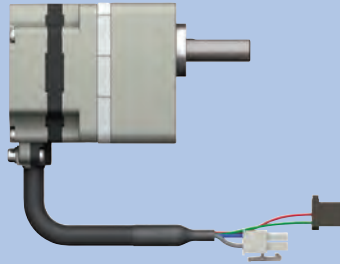

Cable Type Motor
(Degree of Protection IP40 specification)

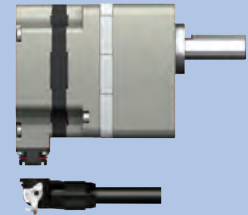

Connection Cable (Sold separately)

Connector Type Motor
(Degree of Protection IP66 specification)

Features

Spin and Push. Easy Speed Control.



Turn the dial, and set the speed to your desired speed.



Turning the dial slowly changes the speed by 1 r/min.



Pushing the dial sets the speed.



The dial operation can be locked.

Easy Wiring. Quick Start.



The motor and driver can be easily connected.



The power and I/O connectors are of the screwless type.



With only one switch, the motor can be started immediately.



The rotation direction of the motor can be changed with easy operation.

Maximum Speed of 4000 r/min Speed Ratio 1:50* (2.5 times of the conventional ratio)

BMU Series has a maximum speed of 4000 r/min*.

Speed ratio of 1:50 (80~4000 r/min*) is realized. Speed regulation has been greatly improved from $\pm 0.5\%$ to $\pm 0.2\%$. With the highest standards of speed control, we respond to our customers' demands.

*Depends on the gearhead.

· **BMU Series 120 W**

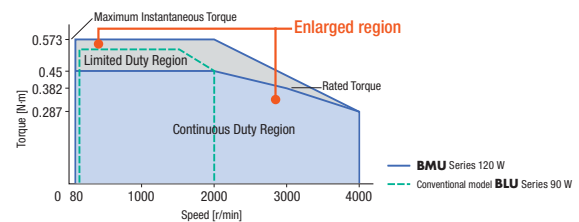

If you open the Front Panel on the Driver, you can set up Various Functions.

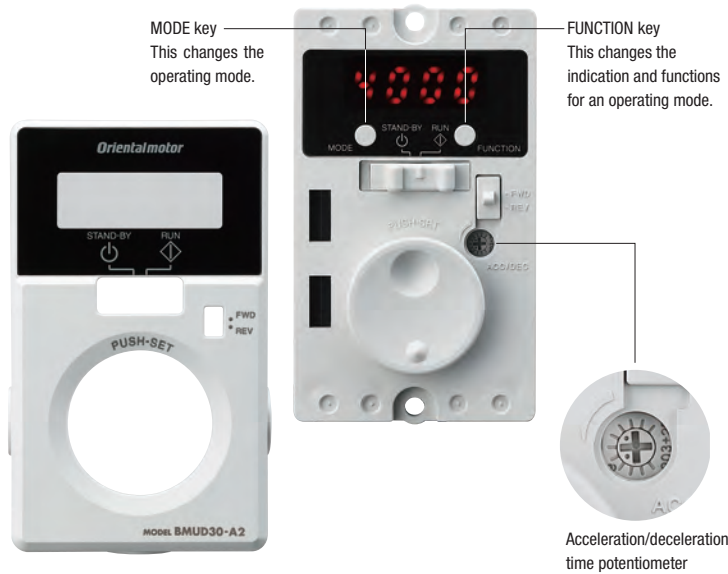

(Typical functions that can be set while the front panel is opened)

- Motor Startup/Stop *
 - Adjustment of operating speed *
 - Setting the operating speed *
 - Selecting the rotation direction *
 - Changing the indication
 - Operating speed indication when the speed reduction/speed increasing ratio is set
 - Setting the acceleration/deceleration time
 - Dial operation lock
 - Speed setting for the 4-speed operation
 - Speed limits setting
 - Validating the external operating signals
 - External input/output signal allocation
 - Setting the overload alarm detection time, except during axial lock
 - Easy holding function for output shaft
- *Setting is possible even if the front panel is attached.

Speed indication

Displays the motor rotational speed by 1 r/min. Additionally, with the "gear ratio" parameter of a conveyor, the display shows the conveyor transfer speed in m/s directly.



Load factor indication

With the rated torque of the motor at 100%, the load factor can be expressed in percentage (40~200%). The load condition during the start-up, as well as the load condition due to the aging deterioration of the equipment can be confirmed.



Indication at a load factor of 50%

Protective function

Various protective functions such as overload protective function and overvoltage protective function are equipped. When a protection is triggered, it shows the alarm code on the display and outputs an alarm signal.



4-speed setting

Operation in 4 speeds is possible by setting the data to operating data No.0, No.1, No.2, or No.3, and switching the input of the M0 and M1 terminals.

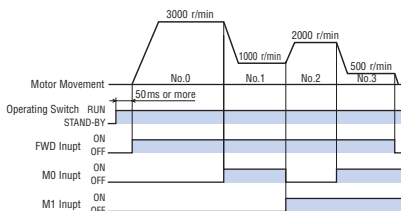

- In 4 speed drive, switching of the rotation direction from external input signals cannot be performed. (For 30, 60, 120 W)

Sets the acceleration/deceleration time

The acceleration time and deceleration time can be digitally set, in addition to adjusting them with an acceleration/deceleration time potentiometer.

- Setting range:
0.0~15.0 sec (Initial value: 0.5 sec)

For the digital setting, the acceleration time and deceleration time are each set independently.

This allows you to finely adjust the speeds to mitigate shocks on conveyed products at startups and stops and freely set them according to the desired tact time.

Output shaft is held when stopped

When the motor is stopped, the load can be electrically held.

(Holding force is up to 50% of the rated torque.)

Note

If the electrical power supply to the driver is turned OFF, the holding force dissipates. This cannot be used to prevent a fall during a power outage.

Other functions

● Lock the dial operation

This prevents the undesired changes in the speed and the changes or deletion of data with the operation of the dial.

● You can set to "Front Panel Operation Invalid"

When operating using external signals, the front panel switch operation can be set to "Invalid".

Features of Connector Type

The connector is new and specially developed for compact motors. It connects the motor and the driver directly. In addition to the motor mechanism, improved dust-resistant and watertight performance has allowed the motor to obtain a Degree of Protection IP66*.

New connector

The built-in gasket and the O-ring contribute to improved watertight performance. The locking lever makes connection easy, eliminating the trouble to fix screws.

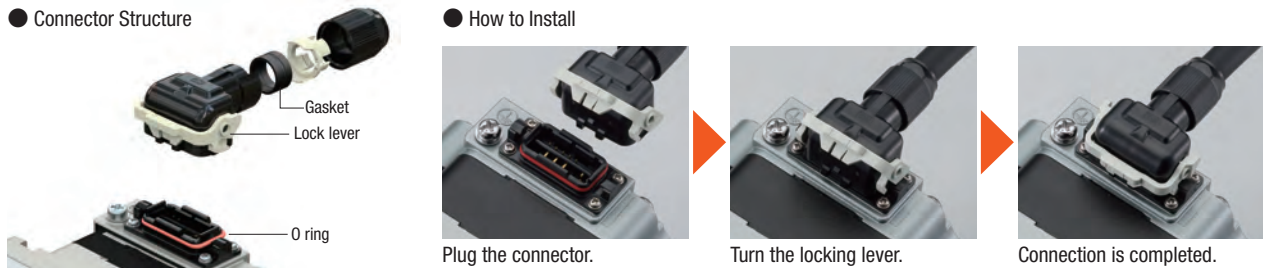

Stainless steel shaft equipped as a standard*

Highly rustproof, anti-corrosive stainless steel is used for the shaft. Stainless steel is also used for the parallel key and the installation screws.

*The protection rating and the output shaft material depend on the gearhead used. For details, refer to the Lineup chart. → Page 12



Cable with Selectable Drawing Direction for Direct Connection

2 types of connection cables are available to choose from depending on the direction to draw out. For direct connections between the motor and the driver, one connection cable can extend up to 10 m, eliminating the need for a relay.

Selectable cable drawing direction

2 types are available to choose from depending on the direction to draw out the motor cable.

(The round shaft type draws only from the counter-output shaft side.)

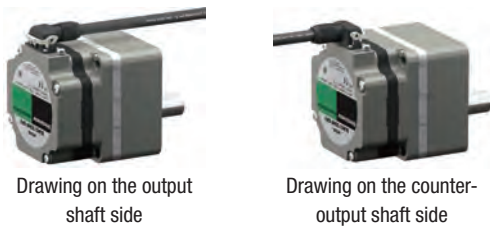

Connects the motor and the driver directly

One cable can extend up to 10 m without a relay, eliminating the need for relays. Only this one cable is required for the power, signals and grounding, reducing wiring efforts.

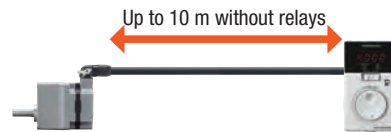

Designed for Compactness, High Power and High Efficiency

An optimal magnetic design and high-performance material enable a stator plate thickness of just 11.2 mm. This slimness realizes a highly efficient power unit that outputs 120 W. Compared with the conventional brushless motor of the same output power, the stator plate thickness is only half of the conventional one (For motors with a frame size of 90 mm).

Moreover, the use of high-performance material reduces the amount of material used, therefore reducing costs.

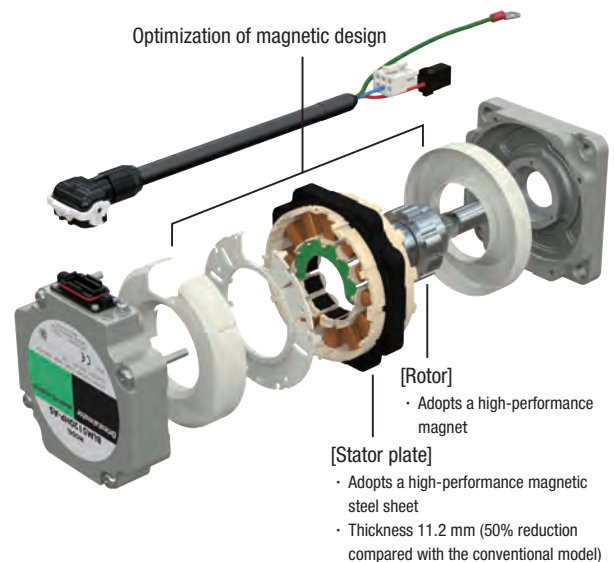

Substantial Improvement in the Efficiency of the Motor and Driver Package

The **BMU** Series sees a maximum of 15% unit efficiency improvement compared with conventional models*.

***BMU** Series 30 W and **BLU** Series 20 W comparison.

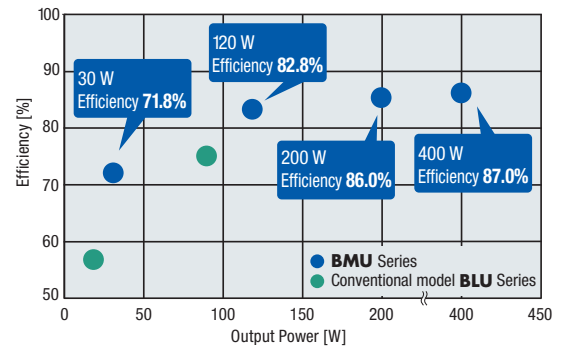

Assembled Motor and Gearhead

The motor and gearhead come pre-assembled. This reduces assembly time and allows immediate installation of the unit to equipment.

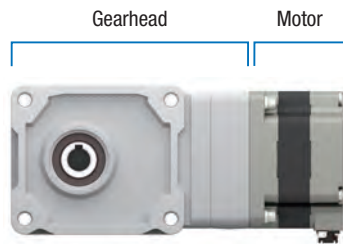



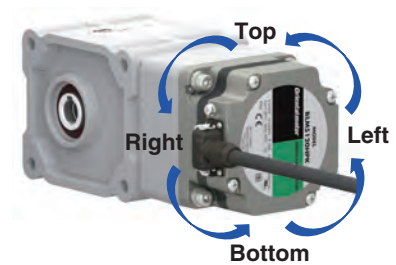
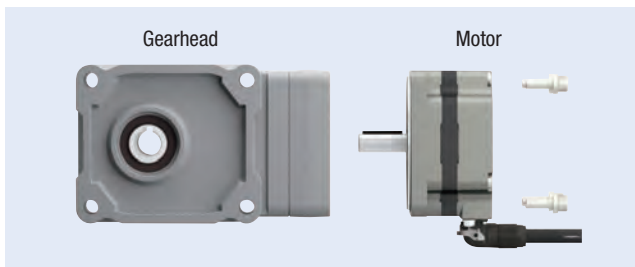

You can remove the gearhead and change the mounting angle by 90-degree intervals. You can change the connector position depending on the equipment.

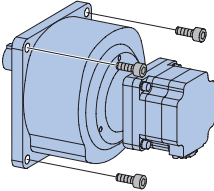
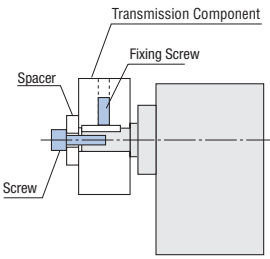
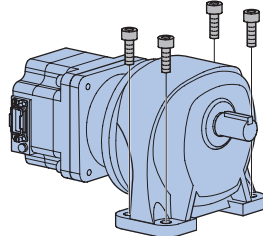

Types and Features of Gearheads

These high-strength gearheads support high-speed rotation and high outputs the brushless motors provide. You can choose from various gearheads to meet your application, requirements, or installation.

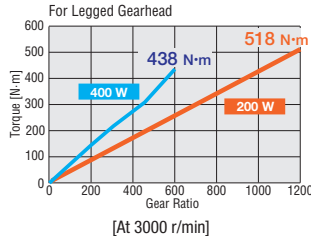
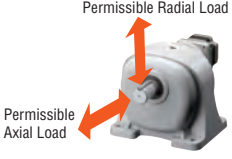
	<h2>Parallel Shaft Gearhead</h2>	<h2>Legged Gearhead</h2>																																																									
<p>Type</p>	<div style="display: flex; justify-content: space-around;"> <div style="text-align: center;">  <p>IP66</p> <p>Parallel Shaft Gearhead GFV Gear</p> </div> <div style="text-align: center;">  <p>IP66</p> <p>Parallel Shaft Gearhead JV Gear</p> </div> </div>	<div style="text-align: center;">  <p>IP44</p> <p>Legged Gearhead JB Gear</p> </div>																																																									
<p>Installation Advantages</p>	<ul style="list-style-type: none"> ● Installs on the Flange (JV Gear)  ● Improving the Installation Accuracy (GFV Gear) The boss of the output shaft and the installation surface are cut. This improves the accuracy of device installation. ● Tapped Hole on the Output Shaft End (GFV Gear • □ 80 mm or more) The output shaft for the gearhead has a tapped hole at the end. The hole can be used for supporting the prevention of coming out of a transmission component.  <p>Usage example of the screw hole on the output shaft end</p> 	<ul style="list-style-type: none"> ● No Mounting Bracket Required The shape quickly attach to your device.  ● High Rigidity/Integral Structure Allows you to easily design the shaft center with the integral installation surface structure.  <p>Installation surface integrated type</p> 																																																									
	<ul style="list-style-type: none"> ● High Strength Gearhead (GFV Gear) A heat treatment strengthens the gears and the bearing diameter is enlarged for a higher strength. The gearhead has 2 to 3 times of the permissible torque than AC motor gearheads with the same frame size, contributing to downsized equipment. ● High Gear Ratio (JV Gear) This line has products with gear ratios up to 1/450. <table border="1" style="margin-top: 10px;"> <thead> <tr> <th>Gear Ratio</th> <th>5</th> <th>10</th> <th>15</th> <th>20</th> <th>30</th> <th>50</th> <th>100</th> <th>200</th> <th>300</th> <th>450</th> </tr> </thead> <tbody> <tr> <td>200 W</td> <td>●</td> <td>●</td> <td>●</td> <td>●</td> <td>●</td> <td>●</td> <td>●</td> <td>●</td> <td>●</td> <td>●</td> </tr> <tr> <td>400 W</td> <td>●</td> <td>●</td> <td>●</td> <td>●</td> <td>●</td> <td>●</td> <td>●</td> <td>●</td> <td>●</td> <td>●</td> </tr> </tbody> </table> <p>● represents parallel shaft gearhead GFV gear</p> ● Long Life (GFV Gear) The gearhead has a long life using special bearings and grease for high-speed rotation. It achieves a rated life of 10,000 hours. 	Gear Ratio	5	10	15	20	30	50	100	200	300	450	200 W	●	●	●	●	●	●	●	●	●	●	400 W	●	●	●	●	●	●	●	●	●	●	<ul style="list-style-type: none"> ● High Permissible Torque The torque is not saturated and the benefit of the motor torque can be maximized.  ● High Strength  <p>Permissible Radial Load 3672 N Permissible Axial Load 577 N</p> <p>[With 1/1200 gear ratio, at 3000 r/min]</p> ● High Gear Ratio This line has products with gear ratios up to 1/1200. <table border="1" style="margin-top: 10px;"> <thead> <tr> <th>Gear Ratio</th> <th>5</th> <th>10</th> <th>20</th> <th>30</th> <th>50</th> <th>100</th> <th>200</th> <th>300</th> <th>450</th> <th>600</th> <th>1200*</th> </tr> </thead> <tbody> <tr> <td></td> <td>●</td> <td>●</td> <td>●</td> <td>●</td> <td>●</td> <td>●</td> <td>●</td> <td>●</td> <td>●</td> <td>●</td> <td>●</td> </tr> </tbody> </table> <p>*200 W only</p> 	Gear Ratio	5	10	20	30	50	100	200	300	450	600	1200*		●	●	●	●	●	●	●	●	●	●	●
Gear Ratio	5	10	15	20	30	50	100	200	300	450																																																	
200 W	●	●	●	●	●	●	●	●	●	●																																																	
400 W	●	●	●	●	●	●	●	●	●	●																																																	
Gear Ratio	5	10	20	30	50	100	200	300	450	600	1200*																																																
	●	●	●	●	●	●	●	●	●	●	●																																																

Right-Angle Shaft Gearhead

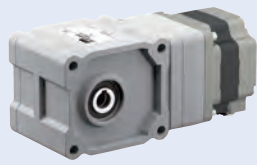

IP66

Hypoid Right-Angle Hollow Shaft **JH** Gear

Space Saving

Placing the motor at right angles saves space.

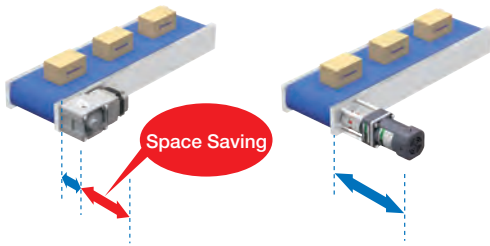

Cost Saving

Reduced couplings, belts, pulleys, and other parts contribute to reduced parts costs and assembling steps.



Unsaturated Permissible Torque

The permissible torque is not saturated even at a high gear ratio. Therefore, the benefit of the motor torque can be maximized.

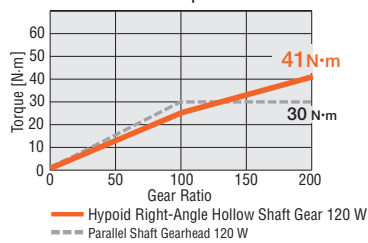

[At 3000 r/min]

High Strength

Comparison with parallel shaft gearhead



[1/200 at 3000 r/min]

Lineup

Motor

Cable Type

Connector Type



Type/material of the output shaft		Output Power [W]	Gear Ratio	Degree of Protection	
Parallel Shaft Gearhead	Cable Type Connector Type GFV Gear Cable Iron Shaft Connector Stainless Steel Shaft	30	5, 10, 15, 20, 30, 50, 100, 200	Cable IP40 Connector IP66	
		60			
		120			
		200			
	Connector Type NEW GFV Gear Supports Food Machinery Grease H1 Stainless steel shaft	30	5, 10, 15, 20, 30, 50, 100, 200	IP66	
		60			
		120			
	Connector Type JV Gear Stainless steel shaft	200	300, 450	IP66	
		400	100, 200, 300, 450		
	Legged Gearhead JB Gear Iron Shaft	Connector Type	200	5, 10, 20, 30, 50, 100, 200, 300, 450, 600, 1200	IP44
			400	5, 10, 20, 30, 50, 100, 200, 300, 450, 600	
	Hypoid Right-Angle Hollow Shaft JH Gear Stainless Steel Shaft	Connector Type	60	10, 15, 20, 30, 50, 100, 200	IP66
120					
200			5, 10, 15, 20, 30, 50, 100, 200		
400					
Round Shaft Type*1 Cable Iron Shaft Connector Stainless Steel Shaft	Cable Type Connector Type	30	-	Cable IP40 Connector IP66	
		60			
		120			
		200			
		400			

Driver



30/60/120 W

200/400 W

Output Power [W]	Power Supply Voltage [VAC]
30	Single-Phase 100-120 Single-Phase 200-240 Three-Phase 200-240
60	
120	
200	Three-Phase 200-240
400	Three-Phase 200-240
30	Single-Phase 100-120 Single-Phase 200-240 Three-Phase 200-240
60	
120	
200	Single-Phase 100-120 Single-Phase 200-240 Three-Phase 200-240
400	Three-Phase 200-240
200	Single-Phase 100-120 Single-Phase 200-240 Three-Phase 200-240
400	Three-Phase 200-240
60	Single-Phase 100-120 Single-Phase 200-240 Three-Phase 200-240
120	
200	
400	Three-Phase 200-240
30	Single-Phase 100-120 Single-Phase 200-240 Three-Phase 200-240
60	
120	
200	
400	

Connection Cable



Cable Type
1~10 m
Connector Type 0.5~10 m
Drawing on the output shaft side
Drawing on the counter-output shaft side*2

*1 Some round shaft types have a milling cut shaft.

*2 The round shaft type can connect only the connection cable drawing from the counter-output shaft.

Product Number Code

● Motor

◇ Parallel Shaft Gearhead **GFV** Gear/Round Shaft Type

BLM 4 60 S H P - 50 S F

① ② ③ ④ ⑤ ⑥ ⑦ ⑧ ⑨

①	Motor Type	BLM: Brushless Motor
②	Frame Size	2: 60 mm 4: 80 mm 5: 90 mm 6: 104 mm (Gearhead is 110 mm)
③	Output Power	30: 30 W 60: 60 W 120: 120 W 200: 200 W 400: 400 W
④	Identification Part Number	S
⑤	Motor Connection Method	Blank: Cable Type H: Connector Type
⑥	Motor Degree of Protection	Blank: IP40 Specifications P: IP66 Specifications
⑦	Gear Ratio/Shaft Shape	Numbers: Gear Ratio of the Gearhead A, A2: Round Shaft Type AC, AC2: Round Shaft Type (With milling cut)
⑧	Material of the Output Shaft	B: Blank: Iron S: Stainless Steel
⑨		F: Supports Food Machinery Grease H1

◇ Hypoid Right-Angle Hollow Shaft **JH** Gear, Legged Gearhead **JB** Gear, Parallel Shaft Gearhead **JV** Gear

BLM 5 200 H P K - 5 C B 50 B - L

① ② ③ ④ ⑤ ⑥ ⑦ ⑧ ⑨ ⑩ ⑪ ⑫ ⑬

Motor Product Name

Gearhead Product Name

Motor Product Name	①	Motor Type	BLM: Brushless Motor
	②	Frame Size	4: 80 mm 5: 90 mm
	③	Output Power	60: 60 W 120: 120 W 200: 200 W 400: 400 W
	④	Identification Part Number	S
	⑤	Motor Connection Method	H: Connector Type
	⑥	Motor Degree of Protection	P: IP66
	⑦	Combination Type Motor	K: Round Shaft Type (With key)
Gearhead Product Name	⑧	Combination Type Motor Frame Size	4: 80 mm 5: 90 mm
	⑨	Gearhead Size	Code (Example) C or the codes of the gearhead size, see Specifications (→ Pages 20, 21 and 24).
	⑩	Gearhead Type	H: JH Gear B: JB Gear V: JV Gear
	⑪	Gear Ratio	Numbers: Gear Ratio of the Gearhead
	⑫	Material of the Output Shaft	S: Stainless Steel B: Iron
	⑬	Connector Position	Blank: Bottom -L: Left

● Driver

BMUD 60 - A 2

① ② ③ ④

①	Driver Type	BMUD: BMU Series Driver
②	Output Power	30: 30 W 60: 60 W 120: 120 W 200: 200 W 400: 400 W
③	Power Supply Voltage	A: Single-Phase 100-120 VAC C: Single-Phase, Three-Phase 200-240 VAC S: Three-Phase 200-240 VAC
④	Reference Number	

● Connection Cable/Flexible Connection Cable (For cable type)

CC 01 BL 2 R

① ② ③ ④ ⑤

①	Cable Type	CC: Connection Cable
②	Length	01: 1 m 02: 2 m 03: 3 m 05: 5 m 07: 7 m 10: 10 m
③	Applied Model	BL: Brushless Motor
④	Reference Number	
⑤	Blank: Connection Cable	R: Flexible Connection Cable

● Connection Cable (For connector type)

CC 010 H BL F

① ② ③ ④ ⑤

①	Cable Type	CC: Connection Cable
②	Length	005: 0.5 m 010: 1 m 015: 1.5 m 020: 2 m 025: 2.5 m 030: 3 m 040: 4 m 050: 5 m 070: 7 m 100: 10 m
③	Motor Connection Method	H: Connector Type
④	Applied Model	BL: Brushless Motor
⑤	Cable Drawing Direction	F: Drawing on the Output Shaft Side B: Drawing on the Counter-output Shaft Side





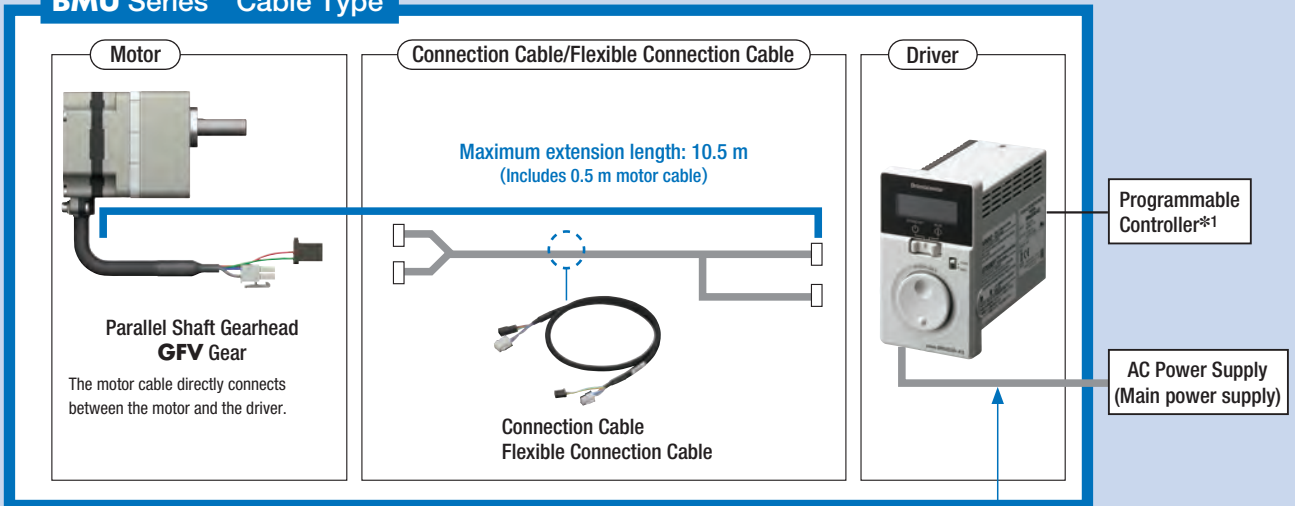

System Configuration Cable Type

The motor, driver, and connection cables need to purchase separately.

BMU Series Cable Type



Accessories

 Flexible Couplings → Page 56	 Motor and Gearhead Mounting Bracket → Page 56	 General-Purpose Cable for I/O Signals → Page 55	 Power Supply Cables → Page 55
 Motor Cover → Page 57	 Dust-Resistant and Watertight Type Front Cover*2 → Page 56	 Circuit Products Mounting Brackets*2 → Page 56	

*1 Not supplied.

*2 Circuit products mounting brackets cannot be used together with the dust-resistant and watertight type front cover.

System Configuration Example

BMU Series Cable Type			Accessories		
Motor Parallel Shaft Gearhead GFV Gear	Driver	Connection Cable (1 m)	Mounting Bracket	Flexible Coupling	Circuit Product Mounting Bracket
BLM230-10B	BMUD30-A2	CC01BL2	SOL2M4F	MCL301010	MAFP05V

The system configuration shown above is an example. Other combinations are available.

Product Line Cable Type

A motor, driver, connection cable need to purchase separately.

Motor

◇ Parallel Shaft Gearhead GFV Gear

Output Power	Product Name	Gear Ratio
30 W	BLM230-□B	5, 10, 15, 20
		30, 50, 100
		200
60 W	BLM460S-□B	5, 10, 15, 20
		30, 50, 100
		200
120 W	BLM5120-□B	5, 10, 15, 20
		30, 50, 100
		200
200 W	BLM6200S-□B	5, 10, 15, 20
		30, 50
		100, 200
400 W	BLM6400S-□B	5, 10, 15, 20
		30, 50

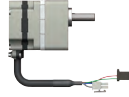

◇ Round Shaft Type

Output Power	Product Name
30 W	BLM230-A2
60 W	BLM260-A2
120 W	BLM5120-A2
200 W	BLM5200-A
400 W	BLM5400-A



Lineup of Other Products

Round Shaft Type
Milling Cut Output Shaft

● For details, contact your nearest Oriental Motor sales office.

Driver

Output Power	Power Supply Voltage	Product Name
30 W	Single-Phase 100-120 VAC	BMUD30-A2
	Single-Phase, Three-Phase 200-240 VAC	BMUD30-C2
60 W	Single-Phase 100-120 VAC	BMUD60-A2
	Single-Phase, Three-Phase 200-240 VAC	BMUD60-C2
120 W	Single-Phase 100-120 VAC	BMUD120-A2
	Single-Phase, Three-Phase 200-240 VAC	BMUD120-C2
200 W	Single-Phase 100-120 VAC	BMUD200-A
	Single-Phase, Three-Phase 200-240 VAC	BMUD200-C
400 W	Three-Phase 200-240 VAC	BMUD400-S



Connection Cables (For cable type)

Length	Product Name
1 m	CC01BL2
2 m	CC02BL2
3 m	CC03BL2
5 m	CC05BL2
7 m	CC07BL2
10 m	CC10BL2



Flexible Connection Cables (For cable type)

Length	Product Name
1 m	CC01BL2R
2 m	CC02BL2R
3 m	CC03BL2R
5 m	CC05BL2R
7 m	CC07BL2R
10 m	CC10BL2R



Accessories (Common among cable and connector types)

Motor

Type	Parallel Key	Safety Cover	Installation Screws	Operating Manual
GFV Gear	1 pc.	—	1 set	1 copy
JV Gear	—	—	—	
JB Gear	—	—	—	
JH Gear	1 pc.	1 pc.	1 set	
Round Shaft	—	—	—	

Driver

Connector	Startup Guide	Operating Manual
<ul style="list-style-type: none"> • CN1 connector (1 pc.) • CN4 connector (1 pc.) 	1 copy	1 copy

● A number in the box □ in the product name indicates the gear ratio.

System Configuration Connector Type

The motor, driver, and connection cables need to purchase separately.

BMU Series Connector Type

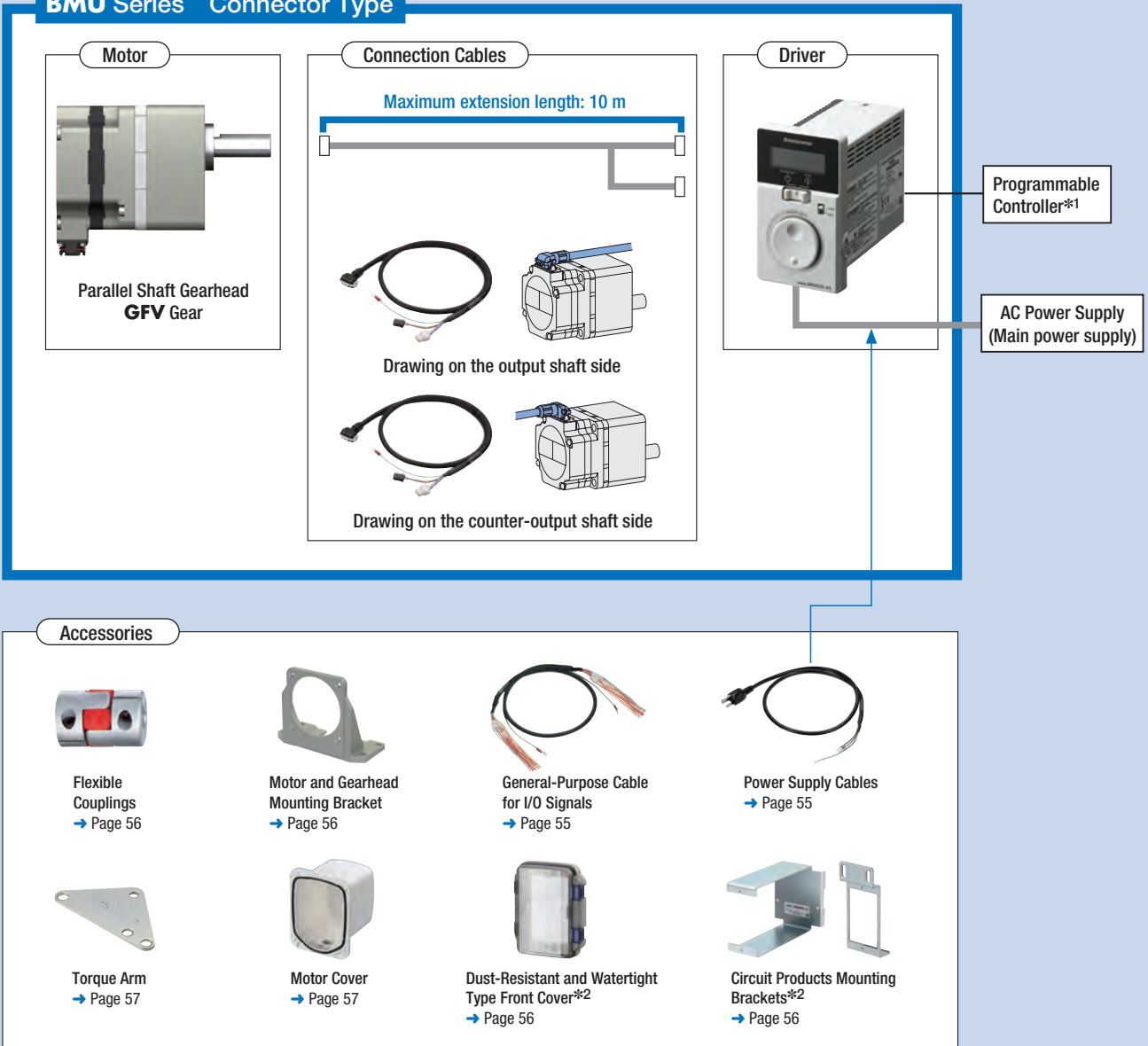

*1 Not supplied.

*2 Circuit products mounting brackets cannot be used together with the dust-resistant and watertight type front cover.

System Configuration Example

BMU Series Connector Type			Accessories		
Motor Parallel Shaft Gearhead GFV Gear	Driver	Connection Cable (3 m)	Mounting Bracket	Flexible Coupling	Circuit Product Mounting Bracket
BLM230HP-10S	BMUD30-A2	CC030HBLF	SOL2M4F	MCL301010	MAFP05V

The system configuration shown above is an example. Other combinations are available.

Product Line Connector Type

A motor, driver, connection cable need to purchase separately.

Motor

◇ Parallel Shaft Gearhead **GFV** Gear

Output Power	Product Name	Gear Ratio
30 W	BLM230HP-□S	5, 10, 15, 20
		30, 50, 100
		200
60 W	BLM460SHP-□S	5, 10, 15, 20
		30, 50, 100
		200
120 W	BLM5120HP-□S	5, 10, 15, 20
		30, 50, 100
		200
200 W	BLM6200SHP-□S	5, 10, 15, 20
		30, 50
		100, 200
400 W	BLM6400SHP-□S	5, 10, 15, 20
		30, 50

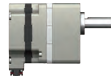

◇ Legged Gearhead **JB** Gear

Output Power	Product Name	Gear Ratio
200 W	BLM5200HPK-5AB□B-L	5, 10, 20
		30, 50
		100, 200
		300, 450
		600, 1200
400 W	BLM5400HPK-5AB□B-L	5, 10, 20
		30, 50
		100, 200
		300, 450
		600



◇ Parallel Shaft Gearhead **GFV** Gear Supports Food Machinery Grease H1

Output Power	Product Name	Gear Ratio
30 W	NEW BLM230HP-□SF	5, 10, 15, 20
		30, 50, 100
		200
60 W	NEW BLM460SHP-□SF	5, 10, 15, 20
		30, 50, 100
		200
120 W	NEW BLM5120HP-□SF	5, 10, 15, 20
		30, 50, 100
		200



◇ Hypoid Right-Angle Hollow Shaft **JH** Gear

Output Power	Product Name	Gear Ratio
60 W	NEW BLM460SHPK-4H□S	10, 15, 20
		30, 50, 100
		200
120 W	BLM5120HPK-5H□S	10, 15, 20
		30, 50, 100
		200
200 W	BLM5200HPK-5XH□S	5, 10, 15, 20
		30
		50
		100
		200
400 W	BLM5400HPK-5XH□S	5, 10, 15, 20
		30
		50
		100
		200



◇ Parallel Shaft Gearhead **JV** Gear

Output Power	Product Name	Gear Ratio
200 W	BLM5200HPK-5KV□S	300, 450
400 W	BLM5400HPK-5DV□S	100, 200
	BLM5400HPK-5KV□S	300, 450



◇ Round Shaft Type

Output Power	Product Name
30 W	BLM230HP-AS
60 W	BLM260HP-AS
120 W	BLM5120HP-AS
200 W	BLM5200HP-AS
400 W	BLM5400HP-AS



Lineup of Other Products

Round Shaft Type
Milling Cut Output Shaft
Connector Position 4-direction selection

● For details, contact your nearest Oriental Motor sales office.

Driver

Output Power	Power Supply Voltage	Product Name
30 W	Single-Phase 100-120 VAC	BMUD30-A2
	Single-Phase, Three-Phase 200-240 VAC	BMUD30-C2
60 W	Single-Phase 100-120 VAC	BMUD60-A2
	Single-Phase, Three-Phase 200-240 VAC	BMUD60-C2
120 W	Single-Phase 100-120 VAC	BMUD120-A2
	Single-Phase, Three-Phase 200-240 VAC	BMUD120-C2
200 W	Single-Phase 100-120 VAC	BMUD200-A
	Single-Phase, Three-Phase 200-240 VAC	BMUD200-C
400 W	Three-Phase 200-240 VAC	BMUD400-S



Connection Cables (For connector type)

Length	Product Name	Length	Product Name
0.5 m	CC005HBL ■	3 m	CC030HBL ■
1 m	CC010HBL ■	4 m	CC040HBL ■
1.5 m	CC015HBL ■	5 m	CC050HBL ■
2 m	CC020HBL ■	7 m	CC070HBL ■
2.5 m	CC025HBL ■	10 m	CC100HBL ■



● The ■ symbol in the product is replaced with **F** or **B** that represents the cable drawing direction.

Two types of connection cables for different cable drawing directions are provided.

Note

● The cable for the round shaft type draws only from the counter-output shaft side.

F: Drawing on the output shaft side

B: Drawing on the counter-output shaft side

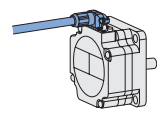
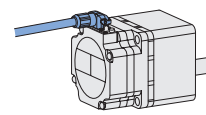
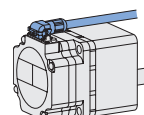

● A number in the box □ in the product name indicates the gear ratio.

● Accessories → Page 15



Specifications

Product Name	Motor	Cable Type Connector Type	BLM230-□B		BLM460S-□B		BLM5120-□B		
			BLM230HP-□S / BLM230HP-□SF	BLM230HP-□S / BLM230HP-□SF	BLM460SHP-□S / BLM460SHP-□SF	BLM460SHP-□S / BLM460SHP-□SF	BLM5120HP-□S / BLM5120HP-□SF	BLM5120HP-□S / BLM5120HP-□SF	
Driver		BMUD30-A2	BMUD30-C2	BMUD60-A2	BMUD60-C2	BMUD120-A2	BMUD120-C2		
Rated Output Power (Continuous)		W		30		60		120	
Power Supply Input	Rated Voltage	VAC	Single-Phase 100-120	Single-Phase 200-240/ Three-Phase 200-240	Single-Phase 100-120	Single-Phase 200-240/ Three-Phase 200-240	Single-Phase 100-120	Single-Phase 200-240/ Three-Phase 200-240	
	Permissible Voltage Range		-15~+10%		-15~+10%		-15~+10%		
	Frequency	Hz	50 / 60		50 / 60		50 / 60		
	Permissible Frequency Range		±5%		±5%		±5%		
	Rated Input Current	A	1.2	Single-Phase: 0.7/ Three-Phase: 0.38	1.7	Single-Phase: 1.0/ Three-Phase: 0.52	3.3	Single-Phase: 2.0/ Three-Phase: 1.1	
	Maximum Input Current	A	2.0	Single-Phase: 1.2/ Three-Phase: 0.75	3.3	Single-Phase: 1.9/ Three-Phase: 1.1	6.8	Single-Phase: 4.1/ Three-Phase: 2.0	
Rated Speed	r/min	3000							
Speed Control Range		80~4000 r/min (Speed ratio 1:50)							
Speed Regulation	Load	±0.2% or less: Conditions 0 to rated torque, rated speed, rated voltage, normal temperature							
	Voltage	±0.2% or less: Conditions Rated voltage -15~+10%, rated speed, no load, normal temperature							
	Temperature	±0.2% or less: Conditions Operating ambient temperature 0~+40°C, rated speed, no load, rated voltage							

● The values correspond to each specification and characteristic of a stand-alone motor.

Gear Ratio		5	10	15	20	30	50	100	200		
Rotation Direction		Same direction as the motor				Opposite direction to the motor				Same direction as the motor	
Output Shaft Rotation Speed [r/min]*1		80 r/min	16	8	5.3	4	2.7	1.6	0.8	0.4	
Permissible Torque [N·m]	30 W	4000 r/min	800	400	267	200	133	80	40	20	
		At 80~2000 r/min	0.45	0.9	1.4	1.8	2.6	4.3	6	6	
		At 3000 r/min	0.43	0.86	1.3	1.7	2.5	4.1	6	6	
		At 4000 r/min	0.32	0.65	0.97	1.3	1.9	3.1	5.4	5.4	
	60 W	At 80~2000 r/min	0.9	1.8	2.7	3.6	5.2	8.6	16	16	
		At 3000 r/min	0.86	1.7	2.6	3.4	4.9	8.2	16	16	
		At 4000 r/min	0.65	1.3	1.9	2.6	3.7	6.2	12.4	14	
		At 80~2000 r/min	2.0	4.1	6.1	8.1	11.6	19.4	30	30	
	120 W	At 3000 r/min	1.7	3.4	5.2	6.9	9.9	16.4	30	30	
		At 4000 r/min	1.3	2.6	3.9	5.2	7.4	12.3	24.7	27	
		10 mm from output shaft end*2	30 W	At 80~3000 r/min	100	150		200			
			At 4000 r/min	90	130		180				
60 W	At 80~3000 r/min	200	300		450						
	At 4000 r/min	180	270		420						
120 W	At 80~3000 r/min	300	400		500						
	At 4000 r/min	230	370		450						
20 mm from output shaft end*2	30 W	At 80~3000 r/min	150	200		300					
	At 4000 r/min	110	170		230						
	60 W	At 80~3000 r/min	250	350		550					
	At 4000 r/min	220	330		500						
120 W	At 80~3000 r/min	400	500		650						
	At 4000 r/min	300	430		550						
Permissible Axial Load [N]		30 W	40								
60 W		100									
120 W		150									
Permissible Load Inertia J [$\times 10^{-4}$ kg·m ²]		30 W	12	50	110	200	370	920	2500	5000	
60 W		22	95	220	350	800	2200	6200	12000		
120 W		45	190	420	700	1600	4500	12000	25000		
At instantaneous stop, instantaneous bi-directional operation*3		30 W	1.55	6.2	14	24.8	55.8	155			
60 W		5.5	22	49.5	88	198	550				
120 W		25	100	225	400	900	2500				

*1 The rotational speed of the output shaft is the value of the rotational speed divided by the gear ratio.

*2 About Load Position → Page 19

*3 It is also applicable when digitally setting the deceleration time to below 0.1 second.

Speed – Torque Characteristics

Continuous Duty Region : Continuous operation is possible in this region.

Limited Duty Region : This region is used primarily when accelerating.

30 W

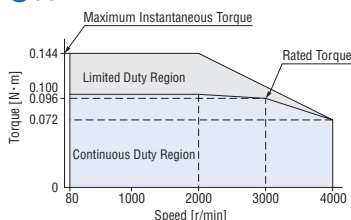

60 W

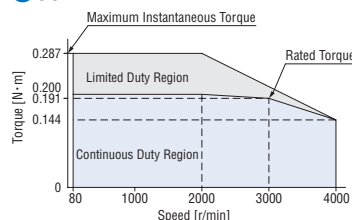

120 W

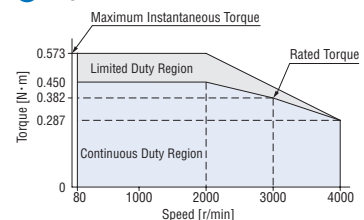

● The values correspond to each specification and characteristic of a stand-alone motor. The speed-torque characteristics shows the values when rated voltage is applied.

● A number in the box □ in the product name indicates the gear ratio.

Parallel Shaft Gearhead GFV Gear 200 W, 400 W



Specifications

Product Name	Motor	Cable Type Connector Type	BLM6200S-□B		BLM6400S-□B
			BLM6200SHP-□S		BLM6400SHP-□S
Driver		BMUD200-A	BMUD200-C		BMUD400-S
Rated Output Power (Continuous)		W	200		400
Power Supply Input	Rated Voltage	VAC	Single-Phase 100-120	Single-Phase 200-240/ Three-Phase 200-240	Three-Phase 200-240
	Permissible Voltage Range		-15~+10%		-15~+10%
	Frequency	Hz	50 / 60		50 / 60
	Permissible Frequency Range		±5%		±5%
	Rated Input Current	A	4.6	Single-Phase: 2.7/Three-Phase: 1.5	2.8
	Maximum Input Current	A	9.3	Single-Phase: 4.9/Three-Phase: 3.4	5.1
Rated Speed		r/min	3000		
Speed Control Range			80~4000 r/min (Speed ratio 1:50)		
Speed Regulation	Load		±0.2% or less: Conditions 0 to rated torque, rated speed, rated voltage, normal temperature		
	Voltage		±0.2% or less: Conditions Rated voltage -15~+10%, rated speed, no load, normal temperature		
	Temperature		±0.2% or less: Conditions Operating ambient temperature 0~+40°C, rated speed, no load, rated voltage		

● The values correspond to each specification and characteristic of a stand-alone motor.

Gear Ratio		5	10	15	20	30	50	100*1	200*1	
Rotation Direction		Same direction as the motor				Opposite direction to the motor		Same direction as the motor		
Output Shaft Rotation Speed [r/min]*2		80 r/min	16	8	5.3	4	2.7	1.6	0.8	0.4
Permissible Torque [N·m]	200 W	4000 r/min	800	400	267	200	133	80	40	20
		At 80~3000 r/min	2.9	5.7	8.6	11.5	16.4	27.4	51.6	70
	400 W	At 4000 r/min	2.2	4.3	6.5	8.6	12.4	20.6	38.9	63
		At 80~3000 r/min	5.7	11.4	17.1	22.9	32.8	54.6	—	—
Permissible Radial Load [N]	10 mm from output shaft end	At 80~3000 r/min	550			1000		1400		
		At 4000 r/min	500			900		1200		
	20 mm from output shaft end	At 80~3000 r/min	800			1250		1700		
		At 4000 r/min	700			1100		1400		
Permissible Axial Load [N]		200			300		400			
Permissible Load Inertia J [$\times 10^{-4}$ kg·m ²]	At instantaneous stop, instantaneous bi-directional operation*3	100	460	1000	1700	3900	9300	18000	37000	
		50	200	450	800	1800	5000			

*1 For 200 W output only.

*2 The rotational speed of the output shaft is the value of the rotational speed divided by the gear ratio.

*3 It is also applicable when digitally setting the deceleration time to below 0.1 second.

◇ About Load Position

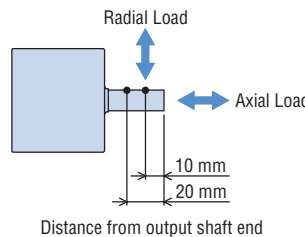

Speed – Torque Characteristics

Continuous Duty Region : Continuous operation is possible in this region.

Limited Duty Region : This region is used primarily when accelerating.

● 200 W

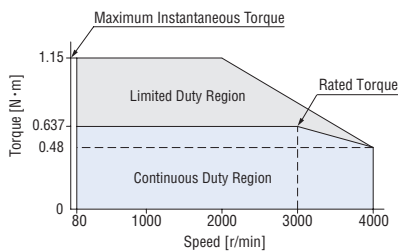

● 400 W

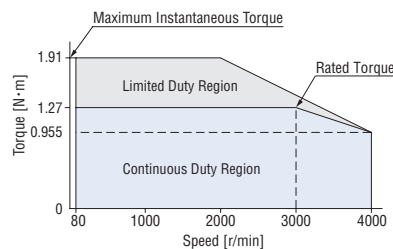

● The values correspond to each specification and characteristic of a stand-alone motor. The speed-torque characteristics shows the values when rated voltage is applied.

● A number in the box □ in the product name indicates the gear ratio.

Parallel Shaft Gearhead JV Gear 200 W, 400 W



Specifications

Product Name	Motor (Connector Type) Driver	BLM5200HPK-5KV□S		BLM5400HPK-5□V□S	
		BMUD200-A	BMUD200-C	BMUD400-S	
Rated Output Power (Continuous)	W	200		400	
Power Supply Input	Rated Voltage	VAC	Single-Phase 100-120	Single-Phase 200-240/ Three-Phase 200-240	
	Permissible Voltage Range		-15~+10%		
	Frequency	Hz	50 / 60		
	Permissible Frequency Range		±5%		
	Rated Input Current	A	4.6	Single-Phase: 2.7/Three-Phase: 1.5	2.8
	Maximum Input Current	A	9.3	Single-Phase: 4.9/Three-Phase: 3.4	5.1
Rated Speed	r/min	3000			
Speed Control Range		80~3600 r/min (Speed ratio 1:45)			
Speed Regulation	Load	±0.2% or less: Conditions 0 to rated torque, rated speed, rated voltage, normal temperature			
	Voltage	±0.2% or less: Conditions Rated voltage -15~+10%, rated speed, no load, normal temperature			
	Temperature	±0.2% or less: Conditions Operating ambient temperature 0~+40°C, rated speed, no load, rated voltage			

● The values correspond to each specification and characteristic of a stand-alone motor.

Gear Ratio	100*1		200*1		300		450	
	(104.1)		(196.4)		(300.5)		(450.8)	
Gearhead Size Code	D				K			
Rotation Direction	Opposite direction to the motor				Same direction as the motor			
Output Shaft Rotation Speed [r/min]*2	80 r/min		0.8	0.4	0.27	0.18		
	3600 r/min		36	18	12	8		
Permissible Torque [N·m]	200 W	At 80~3000 r/min	—	—	132	198		
		At 3600 r/min	—	—	92.3	138		
	400 W	At 80~1500 r/min	108	205	298	431		
		At 3000 r/min	81.9	164	219	302		
Permissible Radial Load [N]	10 mm from output shaft end	At 80~1500 r/min	2888	3483	4461			
		At 3000 r/min	2022	2438	3123			
		At 3600 r/min	1444	1742	2231			
	20 mm from output shaft end	At 80~1500 r/min	3496	4216	5174			
		At 3000 r/min	2447	2951	3622			
		At 3600 r/min	1748	2108	2587			
Permissible Axial Load [N]	At 80~1500 r/min	422	461	686				
	At 3000 r/min	295	323	480				
	At 3600 r/min	211	231	343				
Permissible Load Inertia J [$\times 10^{-4}$ kg·m ²]	At instantaneous stop, instantaneous bi-directional operation*3	At 80~1500 r/min	100000	400000	900000	2025000		
		At 3000 r/min	36000	144000	324000	729000		
		At 3600 r/min	20250	81000	182250	410063		
		At 80~1500 r/min	33333	133333	300000	675000		
		At 3000 r/min	12000	48000	108000	243000		
		At 3600 r/min	6750	27000	60750	136688		

*1 For 400 W output only.

*2 The rotational speed of the output shaft is the value of the rotational speed divided by the gear ratio.

*3 It is also applicable when digitally setting the deceleration time to below 0.1 second.

◇ About Load Position

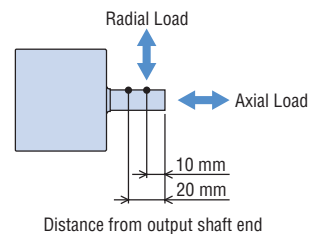

Speed – Torque Characteristics

Continuous Duty Region : Continuous operation is possible in this region.

Limited Duty Region : This region is used primarily when accelerating.

● 200 W

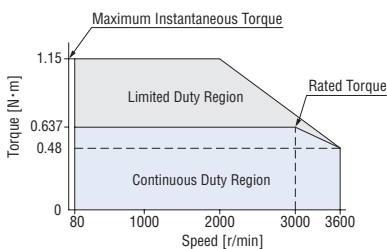

● 400 W

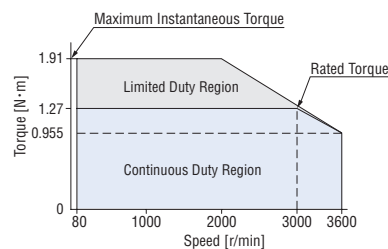

● The values correspond to each specification and characteristic of a stand-alone motor. The speed-torque characteristics shows the values when rated voltage is applied.

● The box □ in a product name is replaced with the code (D, K) that represents the gearhead size.

A number in the box □ in the product name indicates the gear ratio.

Legged Gearhead JB Gear 200 W, 400 W



Specifications

Product Name	Motor (Connector Type)	BLM5200HPK-5 <input type="checkbox"/> B <input type="checkbox"/> B-L		BLM5400HPK-5 <input type="checkbox"/> B <input type="checkbox"/> B-L	
	Driver	BMUD200-A	BMUD200-C	BMUD400-S	
Rated Output Power (Continuous)	W	200		400	
Power Supply Input	Rated Voltage	VAC	Single-Phase 100-120	Single-Phase 200-240/Three-Phase 200-240	
	Permissible Voltage Range		-15~+10%		
	Frequency	Hz	50 / 60		
	Permissible Frequency Range		±5%		
	Rated Input Current	A	4.6	Single-Phase: 2.7/Three-Phase: 1.5	2.8
	Maximum Input Current	A	9.3	Single-Phase: 4.9/Three-Phase: 3.4	5.1
Rated Speed	r/min	3000			
Speed Control Range		80~3600 r/min (Speed ratio 1:45)			
Speed Regulation	Load	±0.2% or less: Conditions	0 to rated torque, rated speed, rated voltage, normal temperature		
	Voltage	±0.2% or less: Conditions	Rated voltage -15~+10%, rated speed, no load, normal temperature		
	Temperature	±0.2% or less: Conditions	Operating ambient temperature 0~+40°C, rated speed, no load, rated voltage		

● The values correspond to each specification and characteristic of a stand-alone motor.

Gear Ratio	Gearhead Size Code												
	5	10	20	30	50	100	200	300	450	600	1200*1		
(Actual gear ratio)	(4.97)	(10.12)	(20.08)	(30.86)	(49.09)	(104.1)	(196.4)	(300.5)	(450.8)	(588.9)	(1178)		
Rotation Direction	Same direction as the motor			Opposite direction to the motor			Same direction as the motor						
Output Shaft Rotation Speed [r/min]*2	80 r/min	16	8	4	2.7	1.6	0.8	0.4	0.27	0.18	0.13	0.07	
	3600 r/min	720	360	180	120	72	36	18	12	8	6	3	
Permissible Torque [N·m]	200 W	At 80~3000 r/min	2.4	4.9	9.7	13.0	22.5	48.4	91.3	132	198	259	518
		At 3600 r/min	1.7	3.4	6.8	8.2	15.6	32.0	60.3	92.3	138	181	362
	400 W	At 80~1500 r/min	5.4	10.9	21.7	31.7	49.9	108	205	298	431	583	—
		At 3000 r/min	4.3	8.3	17.2	25.4	41.2	81.9	164	219	302	438	—
Permissible Radial Load [N]	10 mm from output shaft end	At 80~1500 r/min	521	977	1243	1824	2032	2888	3483	4461	5245	—	
		At 3000 r/min	365	684	870	1277	1422	2022	2438	3123	3672	—	
	20 mm from output shaft end	At 80~1500 r/min	261	489	622	912	1016	1444	1742	2231	2623	—	
		At 3000 r/min	663	1244	1582	2280	2540	3496	4216	5174	5921	—	
Permissible Axial Load [N]	At 80~1500 r/min	At 3000 r/min	464	871	1107	1596	1778	2447	2951	3622	4145	—	
		At 3600 r/min	332	622	791	1140	1270	1748	2108	2587	2961	—	
	At 3000 r/min	At 3600 r/min	39	88	177	255	275	422	461	686	824	—	
		At 3600 r/min	27.3	61.6	124	179	193	295	323	480	577	—	
Permissible Load Inertia J [$\times 10^{-4}$ kg·m ²]	At 80~1500 r/min	At 3000 r/min	19.5	44	88.5	128	138	211	231	343	412	—	
		At 3600 r/min	250	1000	4000	9000	25000	100000	400000	900000	2025000	3600000	14400000
	At 3000 r/min	At 3600 r/min	90	360	1440	3240	9000	36000	144000	324000	729000	1296000	5184000
		At 3600 r/min	50.6	203	810	1823	5063	20250	81000	182250	410063	729000	2916000
	At instantaneous stop, instantaneous bi-directional operation*3	At 80~1500 r/min	83.3	333	1333	3000	8333	33333	133333	300000	675000	1200000	4800000
		At 3000 r/min	30	120	480	1080	3000	12000	48000	108000	243000	432000	1728000
At 3600 r/min	16.9	67.5	270	608	1688	6750	27000	60750	136688	243000	972000		

*1 For 200 W output only.

*2 The rotational speed of the output shaft is the value of the rotational speed divided by the gear ratio.

*3 It is also applicable when digitally setting the deceleration time to below 0.1 second.

◇ About Load Position

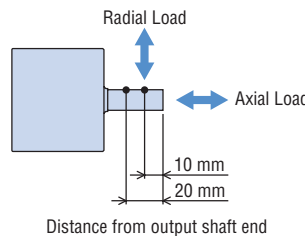

Speed – Torque Characteristics

Continuous Duty Region : Continuous operation is possible in this region.

Limited Duty Region : This region is used primarily when accelerating.

● 200 W

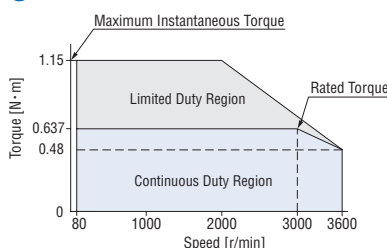

● 400 W

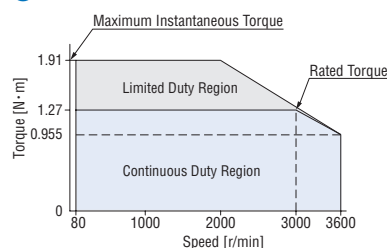

● The values correspond to each specification and characteristic of a stand-alone motor. The speed-torque characteristics shows the values when rated voltage is applied.

● The box in a product name is replaced with the code (A, C, E, K, S) that represents the gearhead size.
A number in the box in the product name indicates the gear ratio.

Hypoid Right-Angle Hollow Shaft JH Gear 60 W, 120 W



Specifications

Product Name	Motor (Connector Type)	BLM460SHPK-4H□S		BLM5120HPK-5H□S		
	Driver	BMUD60-A2	BMUD60-C2	BMUD120-A2	BMUD120-C2	
Rated Output Power (Continuous)	W	60		120		
Power Supply Input	Rated Voltage	VAC	Single-Phase 100-120	Single-Phase 200-240/ Three-Phase 200-240	Single-Phase 100-120	Single-Phase 200-240/ Three-Phase 200-240
	Permissible Voltage Range		-15~+10%			
	Frequency	Hz	50 / 60			
	Permissible Frequency Range		±5%			
	Rated Input Current	A	1.7	Single-Phase: 1.0/ Three-Phase: 0.52	3.3	Single-Phase: 2.0/ Three-Phase: 1.1
	Maximum Input Current	A	3.3	Single-Phase: 1.9/ Three-Phase: 1.1	6.8	Single-Phase: 4.1/ Three-Phase: 2.0
Rated Speed	r/min	3000				
Speed Control Range	r/min	80~3600 (Speed ratio 1:45)				
Speed Regulation	Load	±0.2% or less: Conditions 0 to rated torque, rated speed, rated voltage, normal temperature				
	Voltage	±0.2% or less: Conditions Rated voltage -15~+10%, rated speed, no load, normal temperature				
	Temperature	±0.2% or less: Conditions Operating ambient temperature 0~+40°C, rated speed, no load, rated voltage				

● The values correspond to each specification and characteristic of a stand-alone motor.

Gear Ratio		10	15	20	30	50	100	200		
(Actual gear ratio)		(10.25)	(15.38)	(20.50)	(30.75)	(51.25)	(102.5)	(205.0)		
Rotation Direction*1		Same direction as the motor						Opposite direction to the motor		
Output Shaft Rotation Speed [r/min]*2	80 r/min	8	5.3	4	2.7	1.6	0.8	0.4		
	3600 r/min	360	240	180	120	72	36	18		
Permissible Torque [N·m]	60W	At 80~1500 r/min	1.2	1.8	2.7	4.0	6.7	13.3	20.6	
		At 3000 r/min	1.2	1.8	2.5	3.8	6.4	12.7	15.6	
		At 3600 r/min	0.74	1.1	1.8	2.7	4.4	8.9	11.5	
	120W	At 80~1500 r/min	3.2	4.8	6.5	9.7	16.0	32.3	53.9	
		At 3000 r/min	2.5	3.8	5.1	7.6	12.7	25.5	41.0	
		At 3600 r/min	1.8	2.6	3.5	5.3	8.8	17.7	30.2	
Permissible Radial Load [N]*3	60W	At 80~1500 r/min	265	341	417	531	682	758	836	
		At 3000 r/min	201	259	317	404	518	576	635	
		At 3600 r/min	148	191	234	297	382	424	468	
	120W	At 80~1500 r/min	363	484	605	806	971	1045	1127	
		At 3000 r/min	276	368	460	613	738	794	857	
		At 3600 r/min	203	271	339	451	544	585	631	
Permissible Axial Load [N]	60W	At 80~1500 r/min	88	108	137	177	226	245	275	
		At 3000 r/min	67	82	104	135	172	186	209	
		At 3600 r/min	49	60	77	99	127	137	154	
	120W	At 80~1500 r/min	108	147	186	245	294	324	343	
		At 3000 r/min	82	112	141	186	223	246	261	
		At 3600 r/min	60	82	104	137	165	181	192	
Permissible Load Inertia J [$\times 10^{-4}$ kg·m ²]	60W	At 80~1500 r/min	100	225	400	900	2500	10000	40000	
		At 3000 r/min	36	81	144	324	900	3600	14400	
		At 3600 r/min	20.3	45.6	81	182	506	2025	8100	
		At instantaneous stop, instantaneous bi-directional operation*4	At 80~1500 r/min	200	450	800	1800	5000	20000	80000
			At 3000 r/min	72	162	288	648	1800	7200	28800
			At 3600 r/min	40.5	91.1	162	365	1013	4050	16200
	120W	At 80~1500 r/min	33.3	75	133	300	833	3333	13333	
		At 3000 r/min	12	27	48	108	300	1200	4800	
		At 3600 r/min	6.8	15.2	27	60.8	169	675	2700	
		At 80~1500 r/min	66.7	150	267	600	1667	6667	26667	
		At 3000 r/min	24	54	96	216	600	2400	9600	
		At 3600 r/min	13.5	30.4	54	122	338	1350	5400	

*1 The rotational direction is viewed from the gear flange surface (Figure on the right).

*2 The rotational speed of the output shaft is the value of the rotational speed divided by the gear ratio.

*3 The radial load at each distance can also be calculated with a formula. → Page 53

*4 It is also applicable when digitally setting the deceleration time to below 0.1 second.

◇ Gear Flange Position

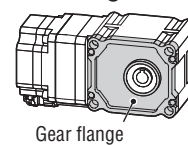

◇ About Load Position

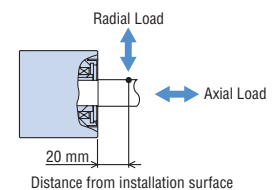

● A number in the box □ in the product name indicates the gear ratio.

Speed – Torque Characteristics

Continuous Duty Region : Continuous operation is possible in this region.

Limited Duty Region : This region is used primarily when accelerating.

● 60 W

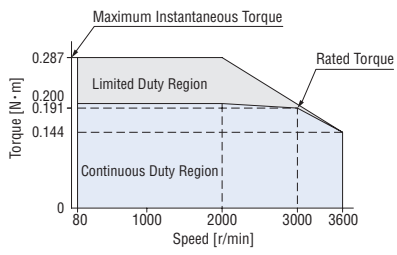

● 120 W

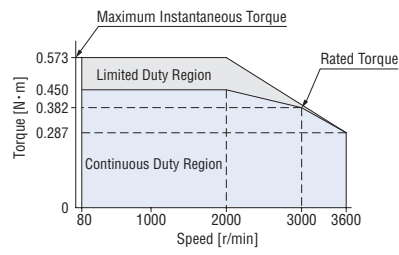

● The values correspond to each specification and characteristic of a stand-alone motor. The speed-torque characteristics shows the values when rated voltage is applied.

Hypoid Right-Angle Hollow Shaft JH Gear 200 W, 400 W



Specifications

Product Name	Motor (Connector Type) Driver	BLM5200HPK-5□H□S		BLM5400HPK-5□H□S	
		BMUD200-A	BMUD200-C	BMUD400-S	
Rated Output Power (Continuous)	W	200		400	
Power Supply Input	Rated Voltage	VAC	Single-Phase 100-120	Single-Phase 200-240/ Three-Phase 200-240	
	Permissible Voltage Range		-15~+10%		
	Frequency	Hz	50 / 60		
	Permissible Frequency Range		±5%		
	Rated Input Current	A	4.6	Single-Phase: 2.7/Three-Phase: 1.5	2.8
	Maximum Input Current	A	9.3	Single-Phase: 4.9/Three-Phase: 3.4	5.1
Rated Speed	r/min	3000			
Speed Control Range		80~3600 r/min (Speed ratio 1:45)			
Speed Regulation	Load	±0.2% or less: Conditions	0 to rated torque, rated speed, rated voltage, normal temperature		
	Voltage	±0.2% or less: Conditions	Rated voltage -15~+10%, rated speed, no load, normal temperature		
	Temperature	±0.2% or less: Conditions	Operating ambient temperature 0~+40°C, rated speed, no load, rated voltage		

● The values correspond to each specification and characteristic of a stand-alone motor.

Gear Ratio	X								Y	
	5	10	15	20	30	50	100	200		
(Actual gear ratio)	(5)	(10)	(15)	(20)	(30)	(50)	(98.95)	(200)		
Gearhead Size Code	X								Y	
Rotation Direction*1	Same direction as the motor								Opposite direction to the motor	
Output Shaft Rotation Speed [r/min]*2	80 r/min	16	8	5.3	4	2.7	1.6	0.8	0.4	
	3600 r/min	720	360	240	180	120	72	36	18	
Permissible Torque [N·m]	200 W	At 80~3000 r/min	2.1	4.1	6.2	8.3	13.4	22.3	41.0	82.8
		At 3600 r/min	1.3	2.6	4.0	5.3	9.4	15.6	28.5	57.6
	400 W	At 80~1500 r/min	4.8	9.5	14.3	19.1	30.5	50.8	88.0	178
		At 3000 r/min	3.8	7.7	11.9	16.1	23.1	38.5	73.5	128
Permissible Radial Load [N]*3	20 mm from installation surface	At 80~1500 r/min	1346	1663	1882	2035	2309	2681	3436	
		At 3000 r/min	942	1164	1317	1425	1616	1877	2405	
		At 3600 r/min	673	832	941	1018	1155	1341	1718	
Permissible Axial Load [N]		At 80~1500 r/min	307	380	429	466	527	613	785	
		At 3000 r/min	215	266	300	326	369	429	550	
		At 3600 r/min	154	190	215	233	264	307	393	
Permissible Load Inertia J [$\times 10^{-4}$ kg·m ²]	At instantaneous stop, instantaneous bi-directional operation*4	At 80~1500 r/min	250	1000	2250	4000	9000	25000	100000	400000
		At 3000 r/min	90	360	810	1440	3240	9000	36000	144000
		At 3600 r/min	50.6	203	456	810	1823	5063	20250	81000
		At 80~1500 r/min	83.3	333	750	1333	3000	8333	33333	133333
		At 3000 r/min	30	120	270	480	1080	3000	12000	48000
		At 3600 r/min	16.9	67.5	152	270	608	1688	6750	27000

*1 The rotational direction is viewed from the gear flange surface (Figure on the right).

*2 The rotational speed of the output shaft is the value of the rotational speed divided by the gear ratio.

*3 The radial load at each distance can also be calculated with a formula. → Page 53

*4 It is also applicable when digitally setting the deceleration time to below 0.1 second.

◇ Gear Flange Position

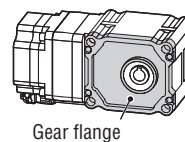

Gear flange

◇ About Load Position

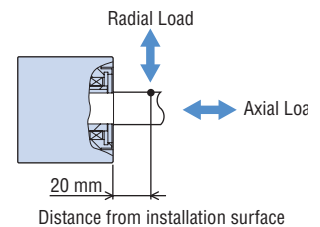

Distance from installation surface

Speed – Torque Characteristics

Continuous Duty Region : Continuous operation is possible in this region.

Limited Duty Region : This region is used primarily when accelerating.

● 200 W

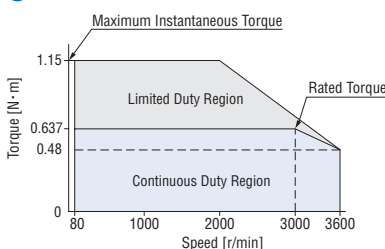

● 400 W

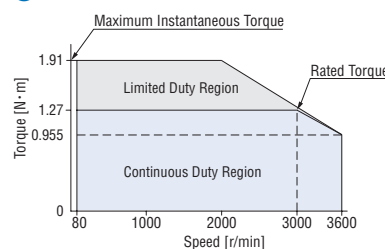

● The values correspond to each specification and characteristic of a stand-alone motor. The speed-torque characteristics shows the values when rated voltage is applied.

● The box □ in a product name is replaced with the code (X, Y) that represents the gearhead size.

A number in the box □ in the product name indicates the gear ratio.

Round Shaft 30 W, 60 W, 120 W



Specifications

Product Name	Motor	Cable Type	BLM230-A2		BLM260-A2		BLM5120-A2	
			BLM230HP-AS		BLM260HP-AS		BLM5120HP-AS	
Driver		BMUD30-A2	BMUD30-C2	BMUD60-A2	BMUD60-C2	BMUD120-A2	BMUD120-C2	
Rated Output Power (Continuous)		30		60		120		
Rated Voltage		Single-Phase 100-120 Single-Phase 200-240/ Three-Phase 200-240		Single-Phase 100-120 Single-Phase 200-240/ Three-Phase 200-240		Single-Phase 100-120 Single-Phase 200-240/ Three-Phase 200-240		
Permissible Voltage Range		-15~+10%		-15~+10%		-15~+10%		
Frequency		50 / 60		50 / 60		50 / 60		
Permissible Frequency Range		±5%		±5%		±5%		
Rated Input Current		1.2	Single-Phase: 0.7/ Three-Phase: 0.38	1.7	Single-Phase: 1.0/ Three-Phase: 0.52	3.3	Single-Phase: 2.0/ Three-Phase: 1.1	
Maximum Input Current		2.0	Single-Phase: 1.2/ Three-Phase: 0.75	3.3	Single-Phase: 1.9/ Three-Phase: 1.1	6.8	Single-Phase: 4.1/ Three-Phase: 2.0	
Rated Speed		3000						
Speed Control Range		80~4000 r/min (Speed ratio 1:50)						
Rated Torque		0.096		0.191		0.382		
Maximum Instantaneous Torque		0.144		0.287		0.573		
Permissible Radial Load		10 mm from output shaft end		80		150		
		20 mm from output shaft end		100		170		
Permissible Axial Load		Half of motor mass or less						
Rotor Inertia J		$\times 10^{-4} \text{kg}\cdot\text{m}^2$ 0.042		$\times 10^{-4} \text{kg}\cdot\text{m}^2$ 0.082		$\times 10^{-4} \text{kg}\cdot\text{m}^2$ 0.23		
Permissible Load Inertia J		$\times 10^{-4} \text{kg}\cdot\text{m}^2$ 1.8		$\times 10^{-4} \text{kg}\cdot\text{m}^2$ 3.75		$\times 10^{-4} \text{kg}\cdot\text{m}^2$ 5.6		
Speed Regulation		Load		±0.2% or less: Conditions 0 to rated torque, rated speed, rated voltage, normal temperature				
		Voltage		±0.2% or less: Conditions Rated voltage -15~+10%, rated speed, no load, normal temperature				
		Temperature		±0.2% or less: Conditions Operating ambient temperature 0~+40°C, rated speed, no load, rated voltage				

About Load Position

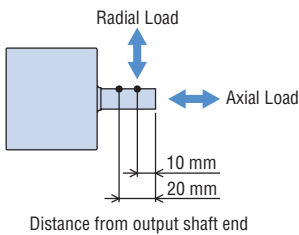

Speed – Torque Characteristics

Continuous Duty Region : Continuous operation is possible in this region.

Limited Duty Region : This region is used primarily when accelerating.

30 W

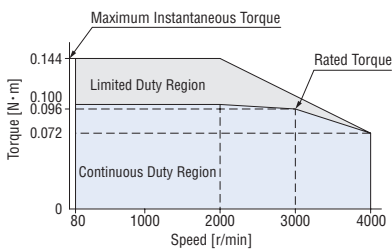

60 W

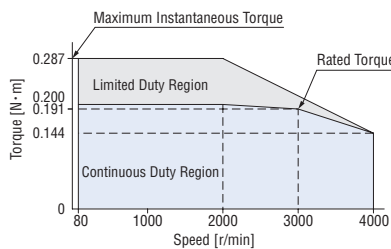

120 W

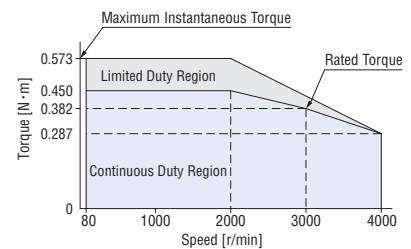

The speed-torque characteristics shows the values when rated voltage is applied.



Specifications

Product Name	Motor	Cable Type	BLM5200-A		BLM5400-A
			BLM5200HP-AS		BLM5400HP-AS
Driver			BMUD200-A	BMUD200-C	BMUD400-S
Rated Output Power (Continuous)		W	200		400
Power Supply Input	Rated Voltage	VAC	Single-Phase 100-120	Single-Phase 200-240/ Three-Phase 200-240	Three-Phase 200-240
	Permissible Voltage Range		-15~+10%		-15~+10%
	Frequency	Hz	50 / 60		50 / 60
	Permissible Frequency Range		±5%		±5%
	Rated Input Current	A	4.6	Single-Phase: 2.7/Three-Phase: 1.5	2.8
	Maximum Input Current	A	9.3	Single-Phase: 4.9/Three-Phase: 3.4	5.1
Rated Speed		r/min	3000		
Speed Control Range			80~4000 r/min (Speed ratio 1:50)		
Rated Torque		N·m	0.637		1.27
Maximum Instantaneous Torque		N·m	1.15		1.91
Permissible Radial Load	10 mm from output shaft end	N	150		
	20 mm from output shaft end	N	170		
Permissible Axial Load			Half of motor mass or less		
Rotor Inertia J		$\times 10^{-4} \text{kg}\cdot\text{m}^2$	0.454		0.67
Permissible Load Inertia J		$\times 10^{-4} \text{kg}\cdot\text{m}^2$	8.75		15
Speed Regulation	Load		±0.2% or less: Conditions 0 to rated torque, rated speed, rated voltage, normal temperature		
	Voltage		±0.2% or less: Conditions Rated voltage -15~+10%, rated speed, no load, normal temperature		
	Temperature		±0.2% or less: Conditions Operating ambient temperature 0~+40°C, rated speed, no load, rated voltage		

◇ About Load Position

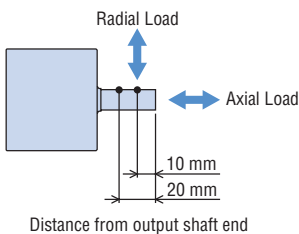

■ Speed – Torque Characteristics

Continuous Duty Region : Continuous operation is possible in this region.

Limited Duty Region : This region is used primarily when accelerating.

● 200 W

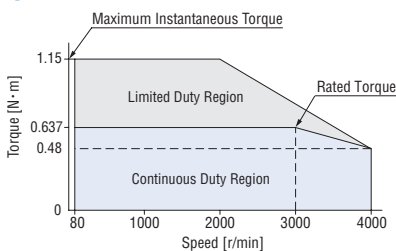

● 400 W

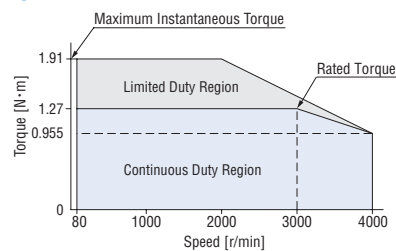

● The speed-torque characteristics shows the values when rated voltage is applied.

Common Specifications

Items	Specifications	
	30 W, 60 W, 120 W	200 W, 400 W
Speed Setting Methods	Digital setting by the dial 4 speed settings possible	
Acceleration/Deceleration Time	Analog setting: 0.1~15.0 s (Time setting from stopped state until reaching the rated speed) Common settings for acceleration/deceleration time with the use of acceleration/deceleration time potentiometer* Digital setting: 0.0~15.0 s (Time setting from current speed to the setting speed) Individual settings for acceleration time/deceleration time for each operating data* * Acceleration time/deceleration time varies with the load condition of the motor.	
Input Signals	Photocoupler input Input resistance: 5.7 kΩ Run by internal power supply: 5 VDC Connectable external DC power supply: 24 VDC -15~+20% 100 mA or more Sink input/Source input Supplied through external wiring	Photocoupler input Input resistance: 6.6 kΩ Run by internal power supply: 5 VDC Connectable external DC power supply: 24 VDC -15~+20% 100 mA or more Sink input/Source input Supplied through external wiring
Output Signals	Signals can be assigned randomly to X0~X2 inputs (3 points) [FWD], [REV], [MO], M1, ALARM-RESET, EXT-ERROR, H-FREE []: Initial setting	Signals can be assigned randomly to IN0~IN4 inputs (5 points) [FWD], [REV], [MO], [M1], [ALARM-RESET], EXT-ERROR, H-FREE []: Initial setting
Protective Function	Photocoupler and open collector output External power supply: 4.5~30 VDC 100 mA or less Sink output/Source output Supplied through external wiring	
Max. Extension Distance	When the following protective functions are activated, ALARM-OUT1 output turns OFF and the motor will undergo a coasting stop. At the same time, the alarm code will be displayed. (Instantaneous stop for external stop only) Overcurrent, main circuit overheating, overvoltage, undervoltage, sensor error, overload, overspeed, EEPROM error, initial sensor error, initial operation inhibition, external stop	
Time Rating	Motor and driver distance 10.5 m [When using an optional connection cable (for relay)] Continuous	

Overload alarm detection time
The overload alarm is generated if the operation goes beyond the continuous duty region.
The detection time for this overload alarm can be set from 0.1~60.0 seconds. (Initial setting: 30.0 seconds)
However, alarm will be generated within 5 seconds in the following cases:
· If an applied load goes beyond the limited duty region
· If the output shaft is locked

General Specifications

Items	Motor	Driver
Insulation Resistance	The measured value is 100 MΩ or more when 500 VDC megger is applied between the windings and the case after continuous operation under normal ambient temperature and humidity.	The measured value is 100 MΩ or more when 500 VDC megger is applied between the power supply terminal and the protective earth terminal, and between the power supply terminal and the I/O signal terminal after continuous operation under normal ambient temperature and humidity.
Dielectric Strength Voltage	Sufficient to withstand 1.5 kVAC at 50 Hz applied between the windings and the case for 1 minute after continuous operation under normal ambient temperature and humidity.	No abnormality is judged even with application of 1.5 kVAC at 50 Hz between the power supply terminal and the protective earth terminal, and with application of 1.5 kVAC at 50 Hz between the power supply terminal and the I/O terminal, for 1 minute after continuous operation under normal ambient temperature and humidity.
Temperature Rise	Temperature rise of the windings is 50° C max. (60° C or less for 400 W) and that of the case is 40° C max. (50° C or less for 400 W)*1, measured by the thermocouple method after rated continuous operation under normal ambient temperature and humidity.	Temperature rise of the heat sink is 50° C or less measured by the thermocouple method after rated continuous operation under normal ambient temperature and humidity.
Operating Environment	Ambient Temperature	0~+40° C (Non-freezing)
	Ambient Humidity	85% or less (Non-condensing)
	Altitude	Up to 1000 m above sea level
	Atmosphere	No corrosive gases or dust. The product should not be exposed to oil. Cannot be used in a radioactive area, magnetic field, vacuum, or other special environments.
Storage Condition*2	Vibration	Not subject to continuous vibration or excessive shock. Conforms to JIS C 60068-2-6 "Sine-wave vibration test method" Frequency range: 10~55 Hz, Pulsating amplitude: 0.15 mm, Sweep direction: 3 directions (X, Y, Z), Number of sweeps: 20 times
	Ambient Temperature	-20~+70° C (-10~+60° C for JV Gear, JB Gear, JH Gear) (Non-freezing)
	Ambient Humidity	85% or less (Non-condensing)
	Altitude	Up to 3000 m above sea level (Up to 1000 m above sea level for JV Gear, JB Gear, JH Gear)
Heat-resistant Class	UL/CSA Standards: 105 (A), EN Standards: 120 (E)	
Degree of Protection*3	Cable Type: IP40 Connector Type GFV Gear, JH Gear, JV Gear, Round shaft: IP66 (Except the installation surface of the round shaft type) JB Gear: IP44 (Except the connector for driver connection when a cable is connected)	IP20

*1 For round shaft types, attach to a heat sink (material: aluminum) of one of the following sizes to keep the motor case surface temperature from exceeding 90° C.

30 W type: 115×115 mm Thickness 5 mm, 60 W type: 135×135 mm Thickness 5 mm, 120 W type: 165×165 mm Thickness 5 mm,

200 W type: 200×200 mm Thickness 5 mm, 400 W type: 250×250 mm Thickness 6 mm

*2 The storage condition applies to short periods such as the period during transportation.

*3 The IP indication representing the dust-resistant and watertight performances are defined in IEC 60529 and IEC 60034-5.

Note

● Do not measure insulation resistance or perform a dielectric strength test while the motor and driver are connected.

Materials and Surface Treatment of IP66 Specifications (Motors/Gearheads)

- Material Case: Aluminum, Output shaft: Stainless steel, and Screws: Stainless steel (Externally exposed portion only, except for the protective earth terminal)
- Surface Treatment Case: Coated (except for the installation surfaces of the **GFV** gears and round shaft types)

Dimensions (Unit = mm)

● Motor (Cable type)

● "Mounting screws" are included. Dimensions of Installation Screws → Page 45

● A number in the box □ in the product name indicates the gear ratio.

◇ Parallel Shaft Gearhead **GFV** Gear · 30 W

2D & 3D CAD

Product Name	Motor Product Name	Gearhead Product Name	Gear Ratio	L	Mass kg	2D CAD
BLM230-□B	BLM230-GFV2	GFV2G□	5~20	34	0.92	A1360A
			30~100	38		A1360B
			200	43		A1360C

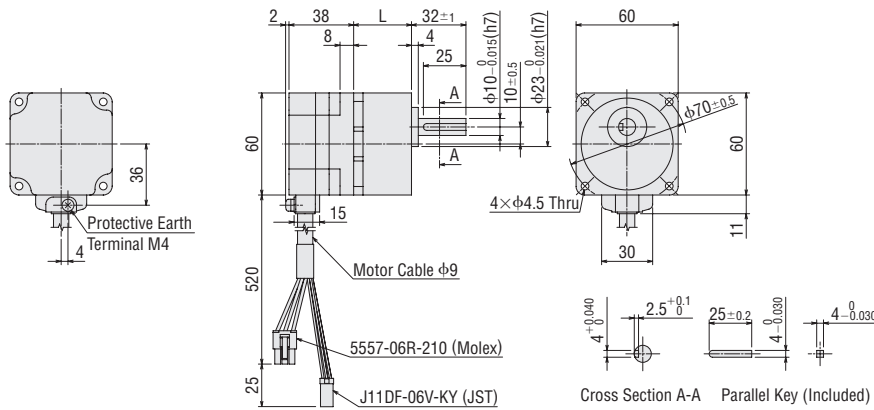

◇ Round Shaft Type · 30 W

BLM230-A2

Mass: 0.42 kg

2D CAD A1362 3D CAD

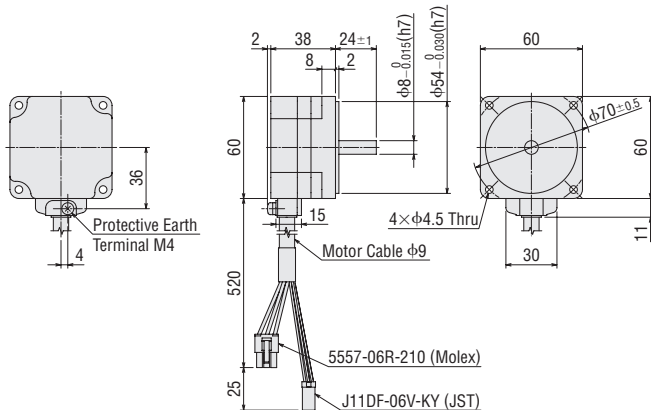

◇ Parallel Shaft Gearhead **GFV** Gear · 60 W

2D & 3D CAD

Product Name	Motor Product Name	Gearhead Product Name	Gear Ratio	L	Mass kg	2D CAD
BLM460S-□B	BLM460S-GFV2	GFV4G□	5~20	41	1.6	A1366A
			30~100	46		A1366B
			200	51		A1366C

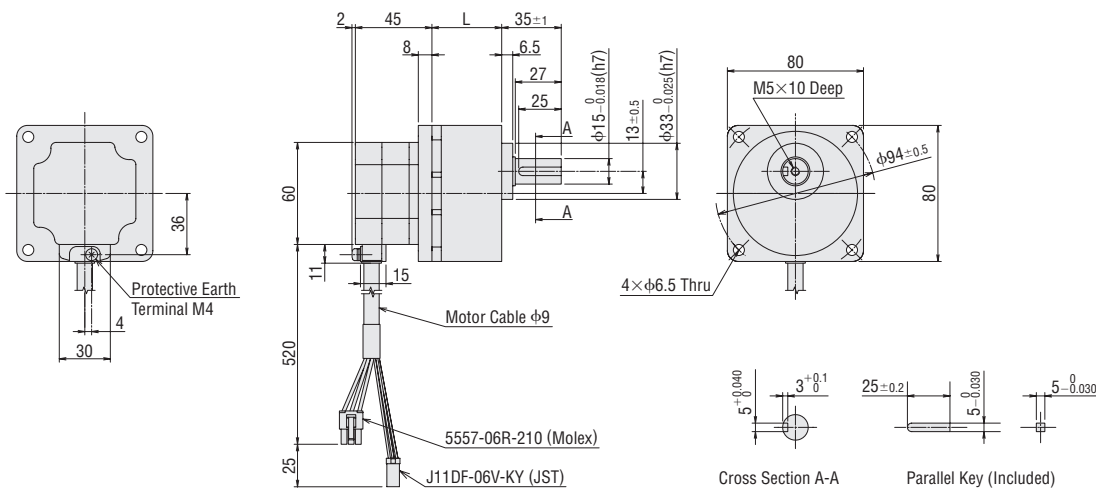

◇ Round Shaft Type · 60 W

BLM260-A2

Mass: 0.55 kg

2D CAD A1368 3D CAD

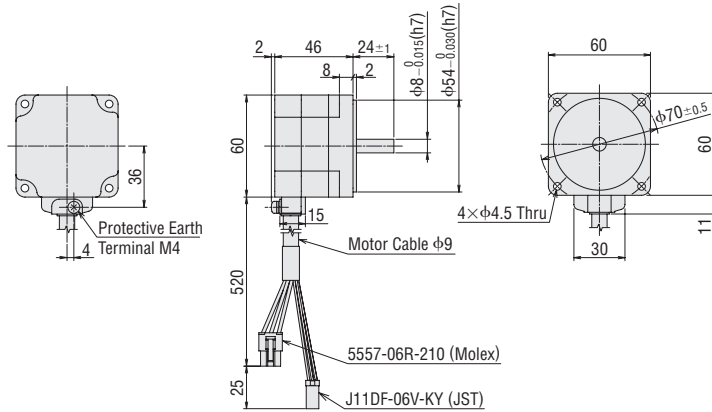

◇ Parallel Shaft Gearhead **GFV Gear** · 120 W

2D & 3D CAD

Product Name	Motor Product Name	Gearhead Product Name	Gear Ratio	L	Mass kg	2D CAD
BLM5120-□B	BLM5120-GFV2	GFV5G□	5~20	45	2.7	A1372A
			30~100	58		A1372B
			200	64		A1372C

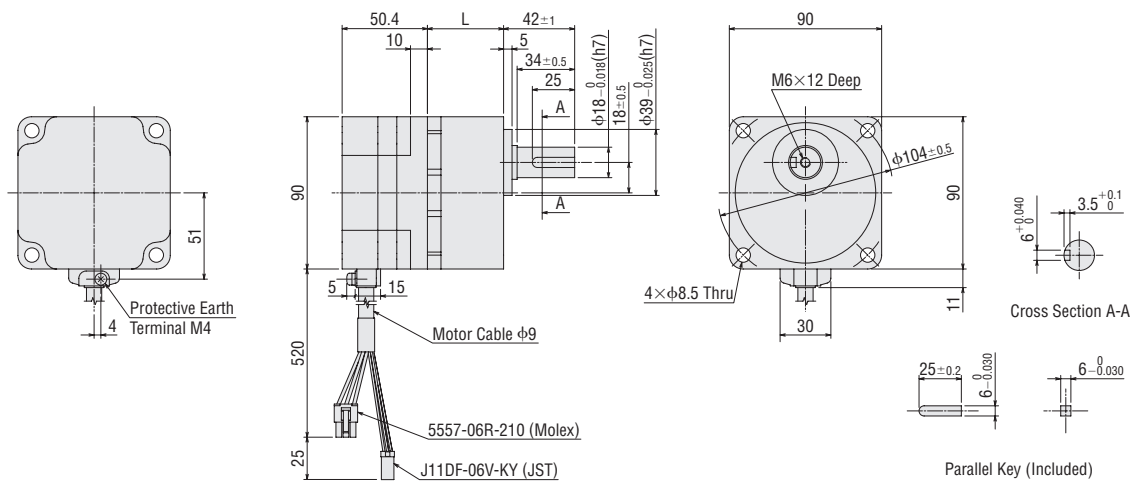

◇ Round Shaft Type · 120 W

BLM5120-A2

Mass: 1.2 kg

2D CAD A1374 3D CAD

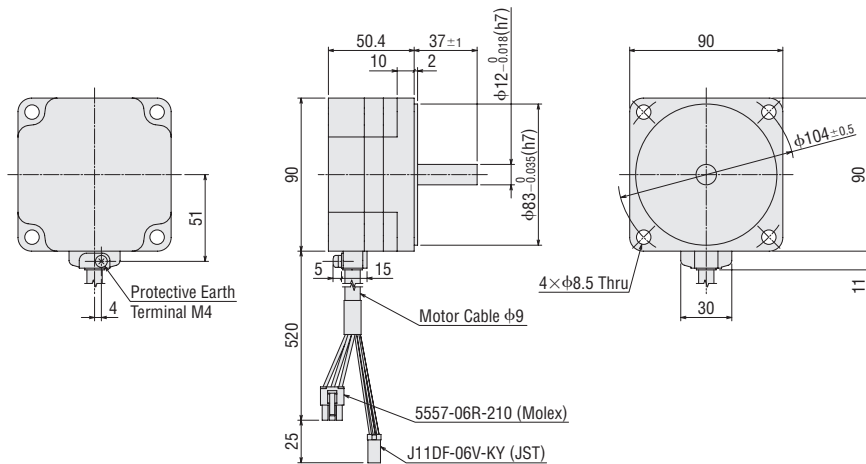

◇ Parallel Shaft Gearhead **GFV Gear · 200 W**

2D & 3D CAD

Product Name	Motor Product Name	Gearhead Product Name	Gear Ratio	L	Mass kg	2D CAD
BLM6200S-□B	BLM6200S-GFV	GFV6G□	5~20	60	4.8	A1340A
			30, 50	72		A1340B
			100, 200	86		A1340C

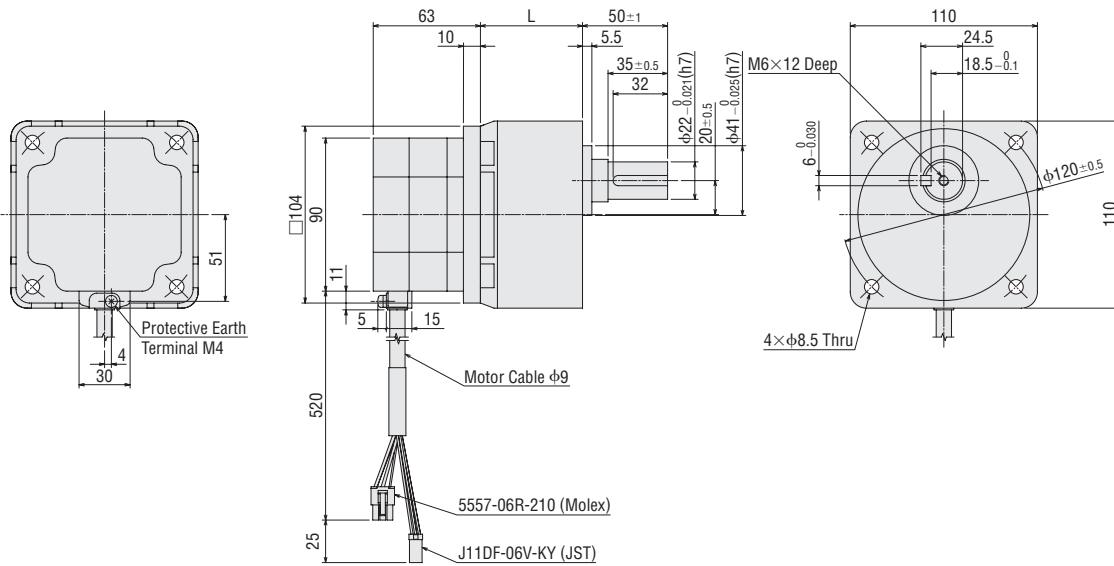

● At the time of shipment, the parallel key is fixed in the key slot of the gearhead shaft.

◇ Round Shaft Type · 200 W

BLM5200-A

Mass: 1.7 kg

2D CAD A1341 3D CAD

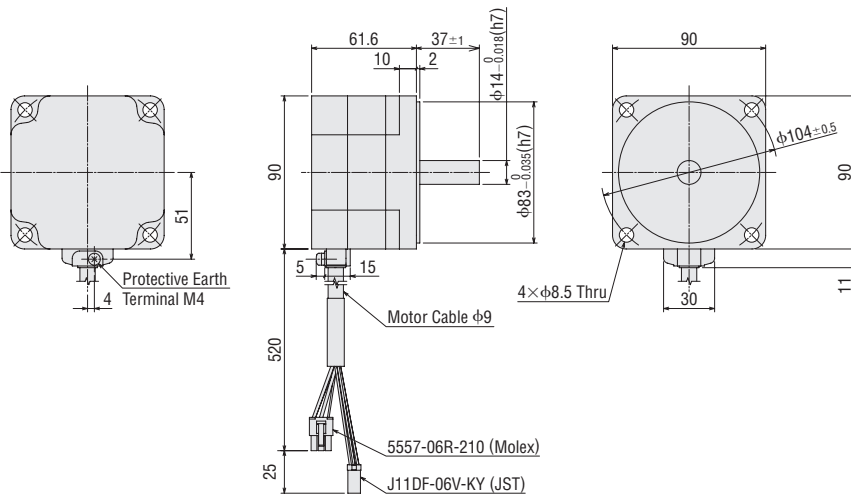

◇ Parallel Shaft Gearhead **GFV Gear** · 400 W

2D & 3D CAD

Product Name	Motor Product Name	Gearhead Product Name	Gear Ratio	L	Mass kg	2D CAD
BLM6400S-□B	BLM6400S-GFV	GFV6G□	5~20	60	5.3	A1413A
			30, 50	72		A1413B

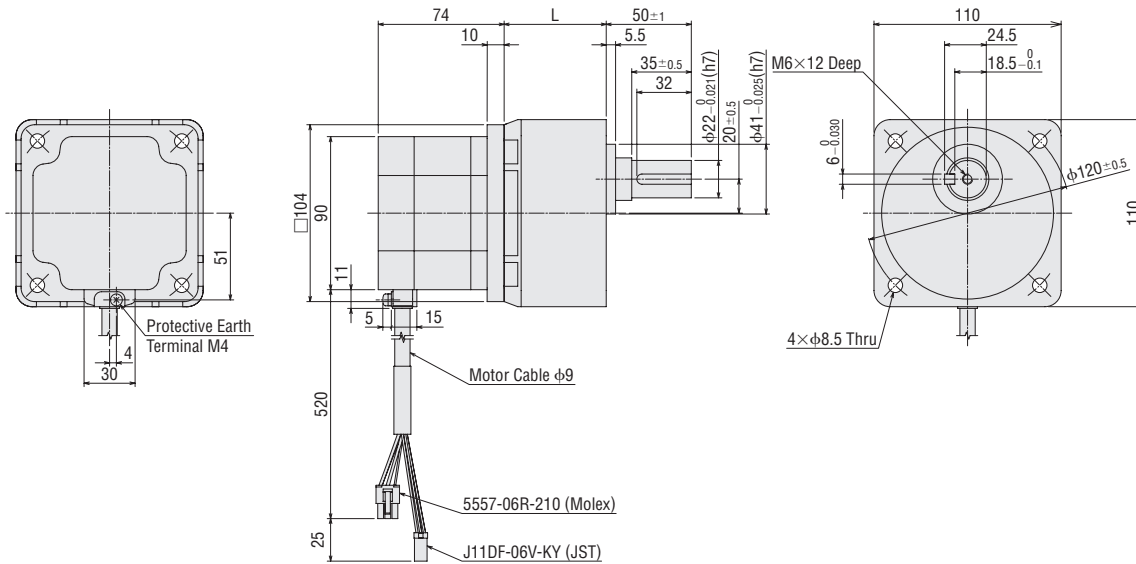

● At the time of shipment, the parallel key is fixed in the key slot of the gearhead shaft.

◇ Round Shaft Type · 400 W

BLM5400-A

Mass: 2.2 kg

2D CAD A1415 3D CAD

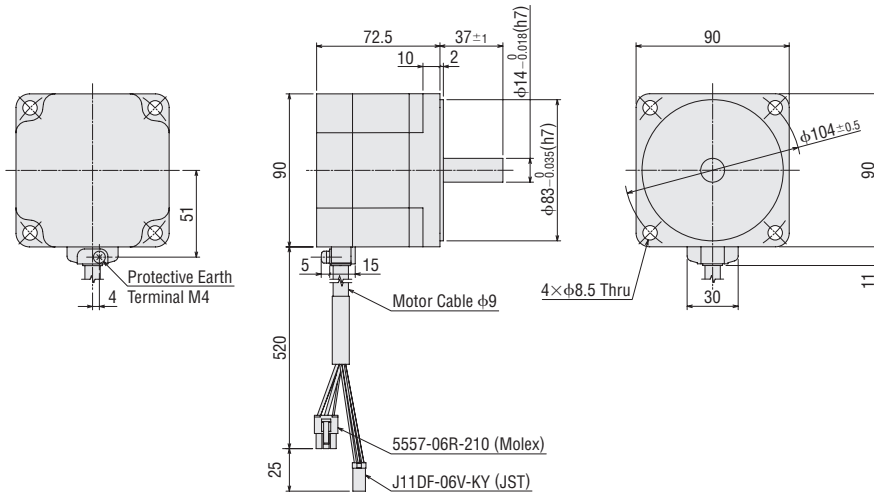

● Motor (Connector type)

- The dimensions drawing of the motor is an example where a separately sold connection cable (portion in the figure) is connected.
The described mass does not include the connection cable. Cable Dimensions and Mass → Page 44
- "Mounting screws" are included. Dimensions of Installation Screws → Page 45
- A number in the box □ in the product name indicates the gear ratio.
The box ■ in a product name is replaced with the code that represents the gearhead size.

◇ Parallel Shaft Gearhead **GFV Gear · 30 W**

2D & 3D CAD

Product Name	Motor Product Name	Gearhead Product Name	Gear Ratio	L	Mass kg	2D CAD	
						Connection cable drawing from the output shaft side is connected	Connection cable drawing from the counter-output shaft side is connected
BLM230HP-□S BLM230HP-□SF	BLM230HP-GFV	GFV2G□S GFV2G□SF	5~20	34	0.63	A1465A	A1466A
			30~100	38	0.68	A1465B	A1466B
			200	43	0.73	A1465C	A1466C

● When connecting the connection cable drawing from the output shaft side

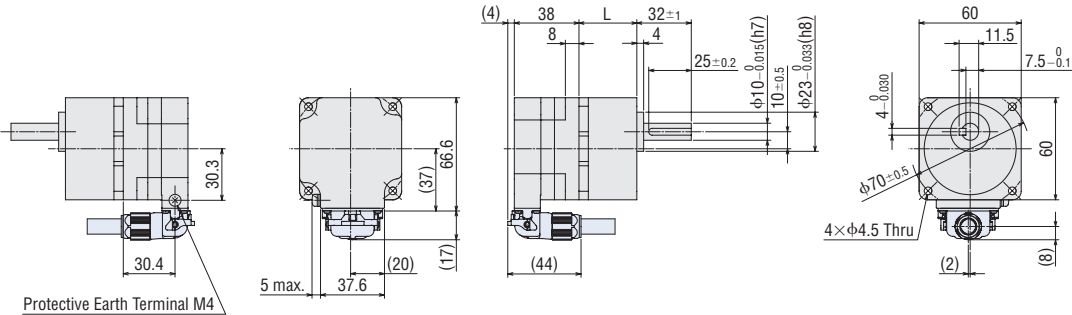

- At the time of shipment, the parallel key is fixed in the key slot of the gearhead shaft.

● When connecting the connection cable drawing from the counter-output shaft side

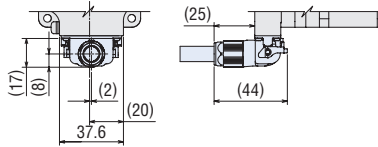

◇ Round Shaft Type · 30 W

BLM230HP-AS

Mass: 0.35 kg

2D CAD A1475 3D CAD

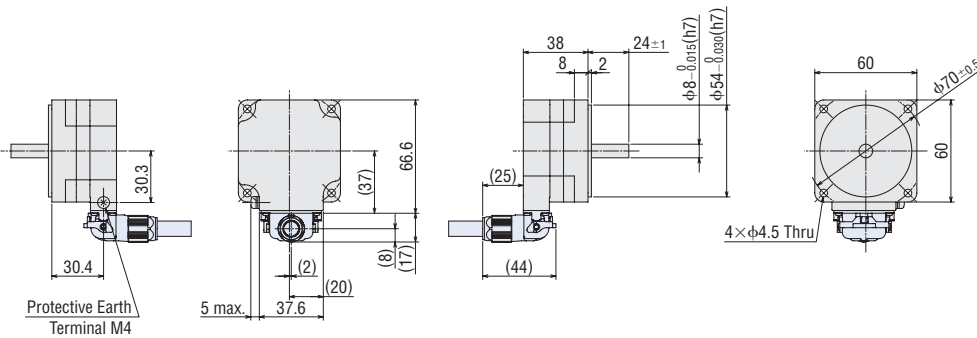

◇ Parallel Shaft Gearhead **GFV Gear** · 60 W

2D & 3D CAD

Product Name	Motor Product Name	Gearhead Product Name	Gear Ratio	L	Mass kg	2D CAD	
						Connection cable drawing from the output shaft side is connected	Connection cable drawing from the counter-output shaft side is connected
BLM460SHP-□S BLM460SHP-□SF	BLM460SHP-GFV	GFV4G□S GFV4G□SF	5~20	41	1.3	A1467A	A1468A
			30~100	46	1.4	A1467B	A1468B
			200	51	1.5	A1467C	A1468C

● When connecting the connection cable drawing from the output shaft side

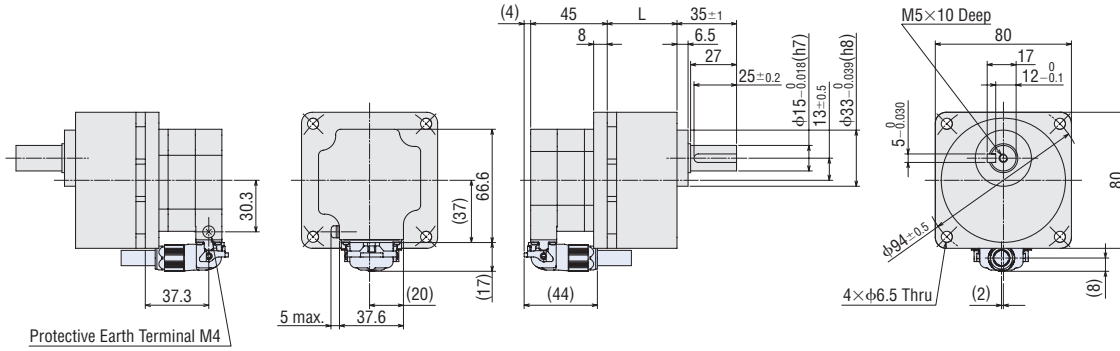

● At the time of shipment, the parallel key is fixed in the key slot of the gearhead shaft.

● When connecting the connection cable drawing from the counter-output shaft side

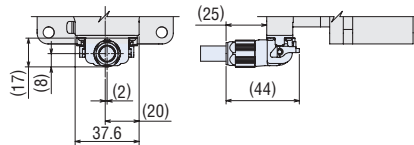

◇ Round Shaft Type · 60 W

BLM260HP-AS

Mass: 0.52 kg

2D CAD A1477 3D CAD

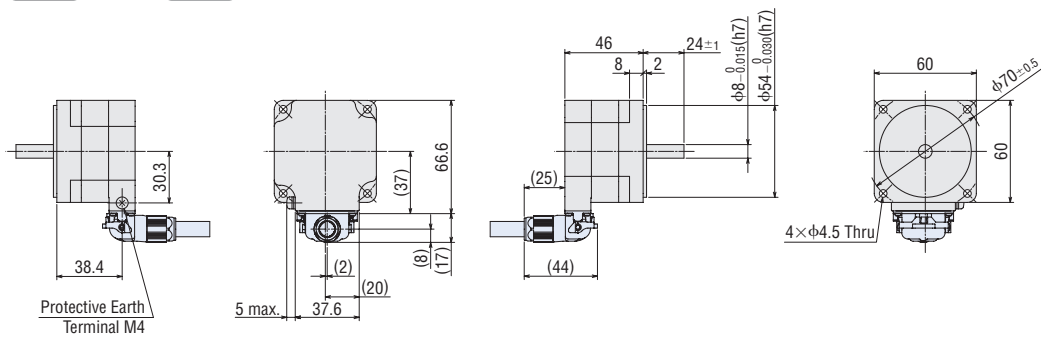

◇ Parallel Shaft Gearhead **GFV Gear · 120 W**

2D & 3D CAD

Product Name	Motor Product Name	Gearhead Product Name	Gear Ratio	L	Mass kg	2D CAD	
						Connection cable drawing from the output shaft side is connected	Connection cable drawing from the counter-output shaft side is connected
BLM5120HP-□S BLM5120HP-□SF	BLM5120HP-GFV	GFV5G□S GFV5G□SF	5~20	45	2.1	A1469A	A1470A
			30~100	58	2.4	A1469B	A1470B
			200	64	2.5	A1469C	A1470C

● When connecting the connection cable drawing from the output shaft side

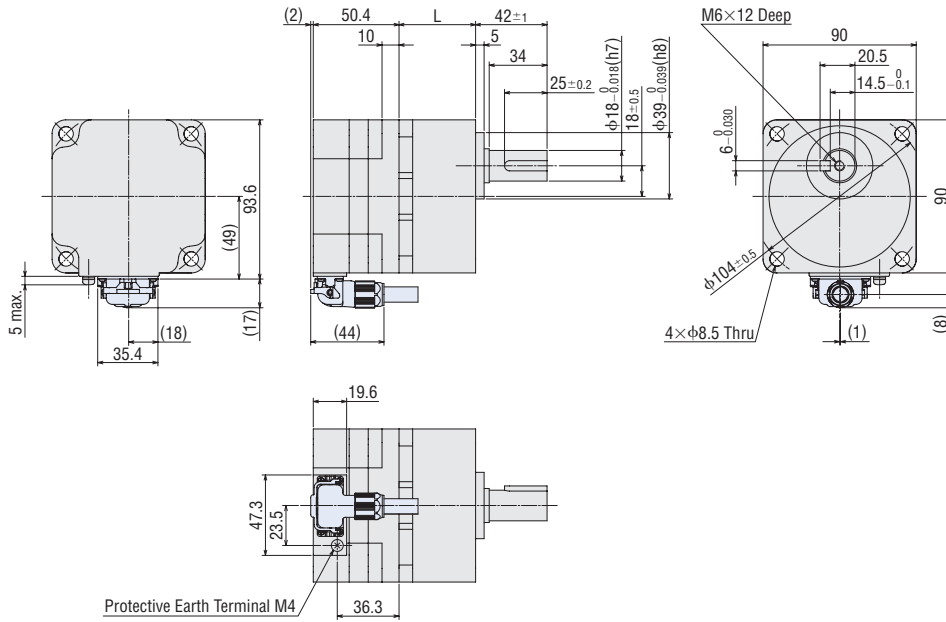

● At the time of shipment, the parallel key is fixed in the key slot of the gearhead shaft.

● When connecting the connection cable drawing from the counter-output shaft side

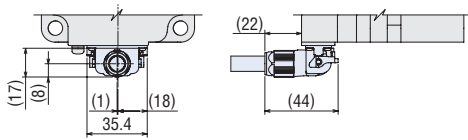

◇ Round Shaft Type · 120 W

BLM5120HP-AS

Mass: 1.1 kg

2D CAD A1479 3D CAD

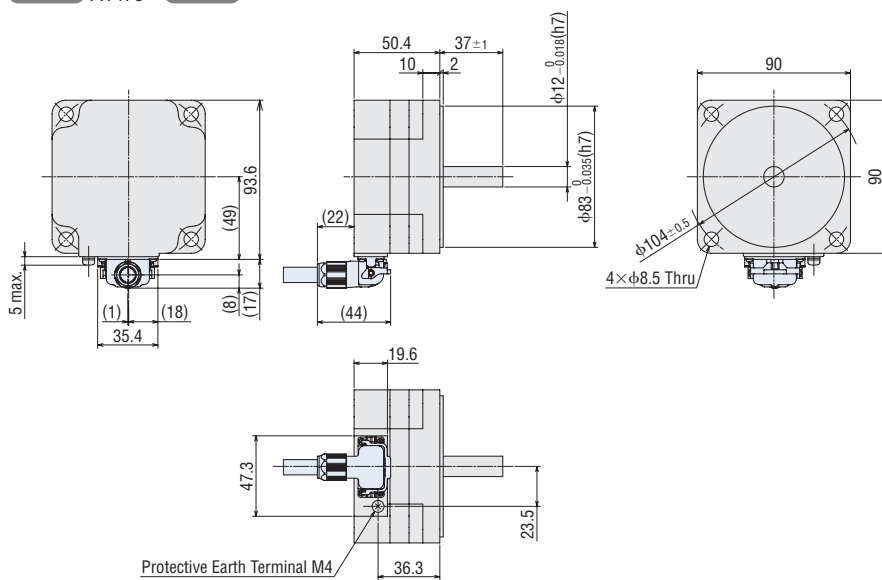

◇ Parallel Shaft Gearhead **GFV Gear · 200 W**

2D & 3D CAD

Product Name	Motor Product Name	Gearhead Product Name	Gear Ratio	L	Mass kg	2D CAD	
						Connection cable drawing from the output shaft side is connected	Connection cable drawing from the counter-output shaft side is connected
BLM6200SHP-□S	BLM6200SHP-GFV	GFV6G□S	5~20	60	4.7	A1471A	A1472A
			30, 50	72		A1471B	A1472B
			100, 200	86		A1471C	A1472C

● When connecting the connection cable drawing from the output shaft side

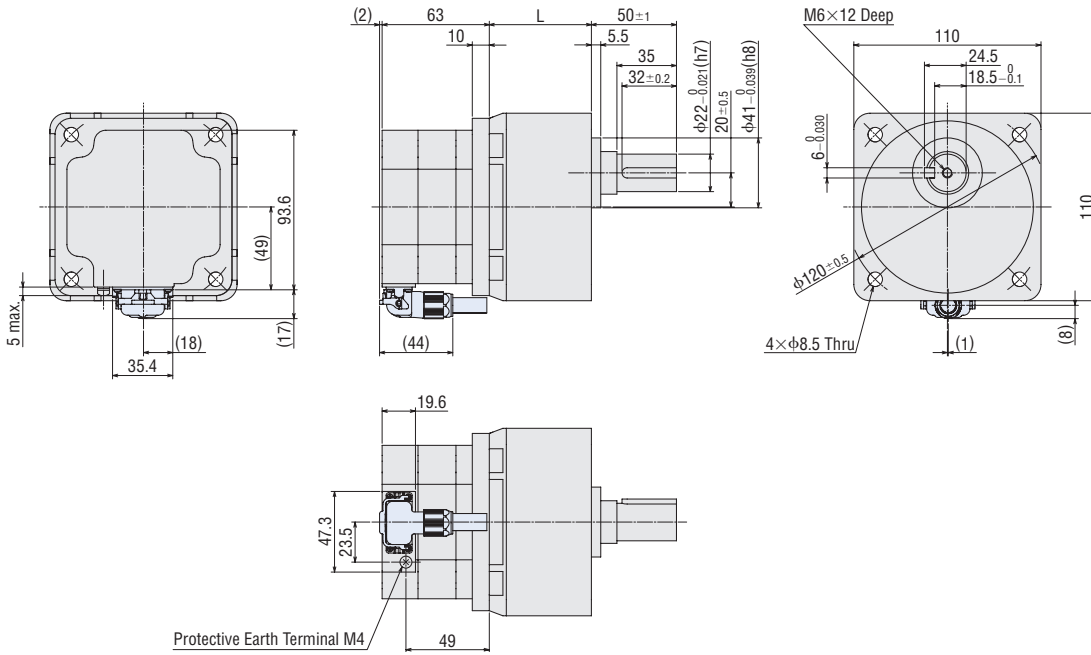

● At the time of shipment, the parallel key is fixed in the key slot of the gearhead shaft.

● When connecting the connection cable drawing from the counter-output shaft side

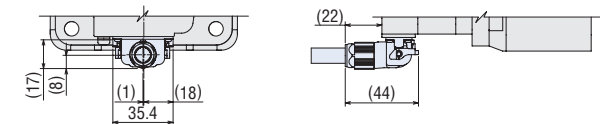

◇ Round Shaft Type · 200 W

BLM5200HP-AS

Mass: 1.6 kg

2D CAD A1481 3D CAD

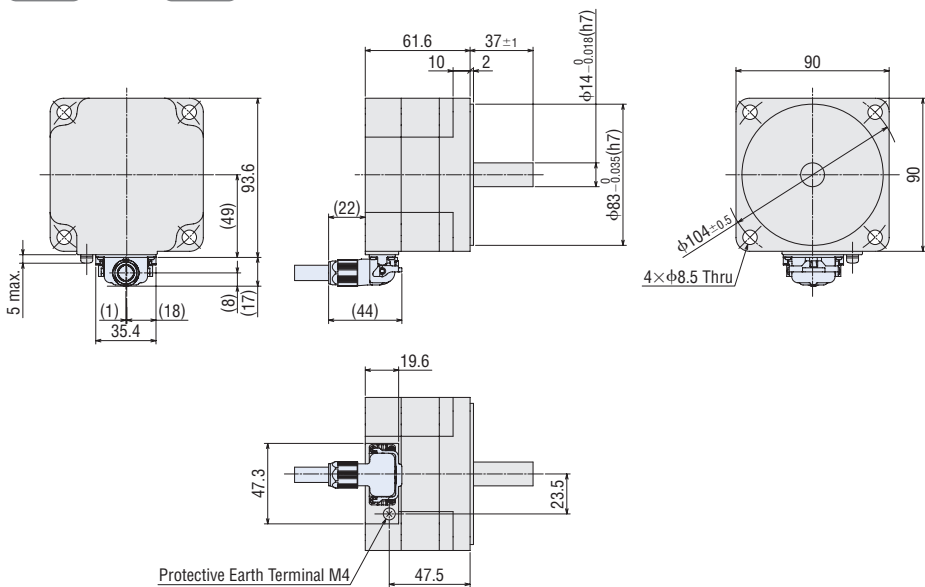

◇ Parallel Shaft Gearhead **GFV Gear** · 400 W

2D & 3D CAD

Product Name	Motor Product Name	Gearhead Product Name	Gear Ratio	L	Mass kg	2D CAD	
						Connection cable drawing from the output shaft side is connected	Connection cable drawing from the counter-output shaft side is connected
BLM6400SHP-□S	BLM6400SHP-GFV	GFV6G□S	5~20	60	5.2	A1473A	A1474A
			30, 50	72		A1473B	A1474B

● When connecting the connection cable drawing from the output shaft side

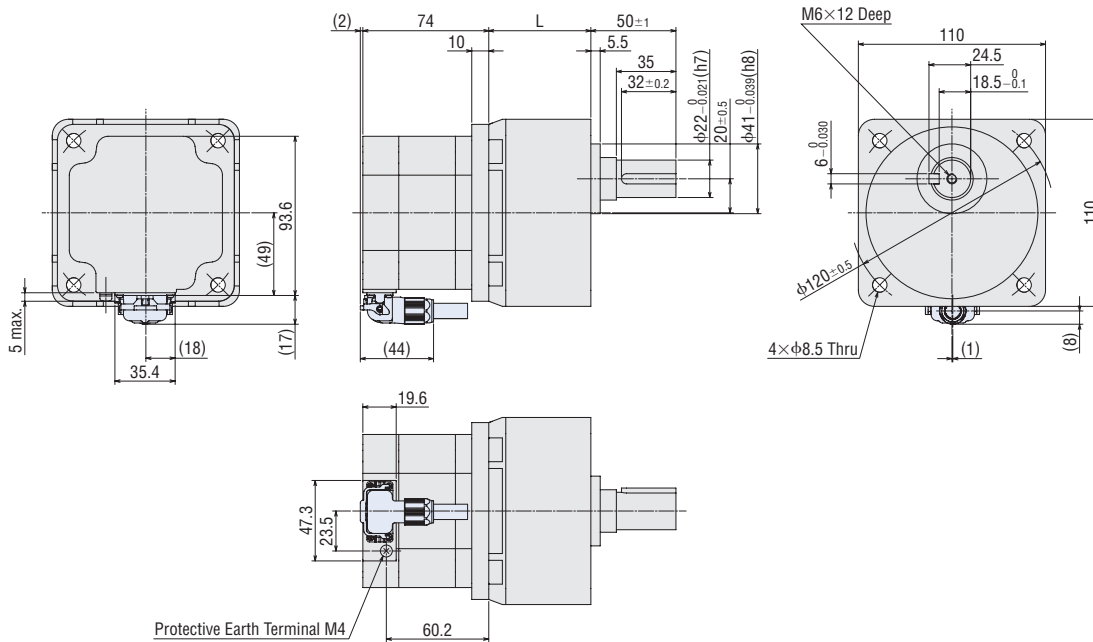

● At the time of shipment, the parallel key is fixed in the key slot of the gearhead shaft.

● When connecting the connection cable drawing from the counter-output shaft side

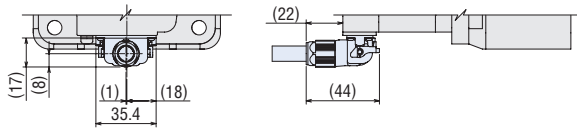

◇ Round Shaft Type · 400 W

BLM5400HP-AS

Mass: 2.1 kg

2D CAD A1483 3D CAD

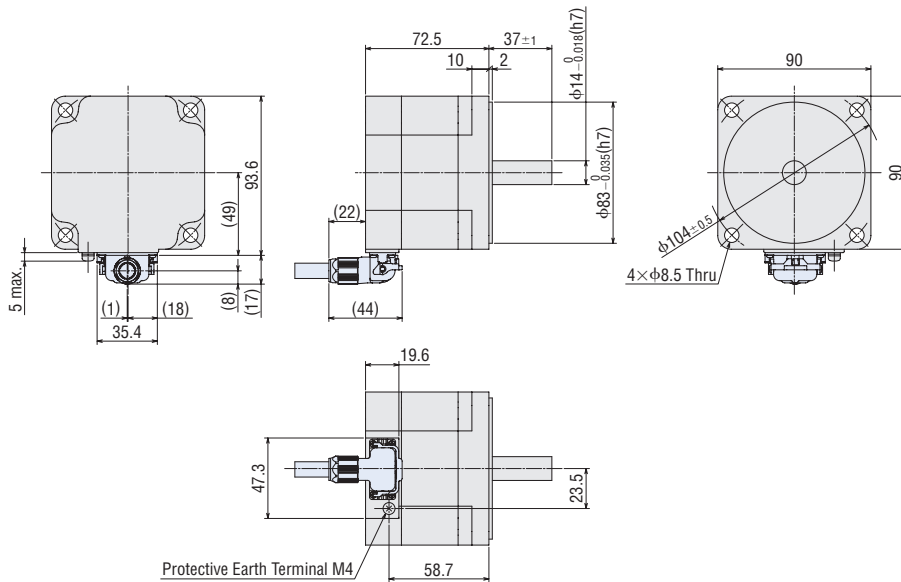

Product Name	Motor Product Name	Gearhead Product Name	Gear Ratio	Mass kg	2D CAD	
					Connection cable drawing from the output shaft side is connected	Connection cable drawing from the counter-output shaft side is connected
BLM5400HPK-5DV□S	BLM5400HPK	5DV□S	100, 200	8.6	A1559	A1560

• When connecting the connection cable drawing from the output shaft side

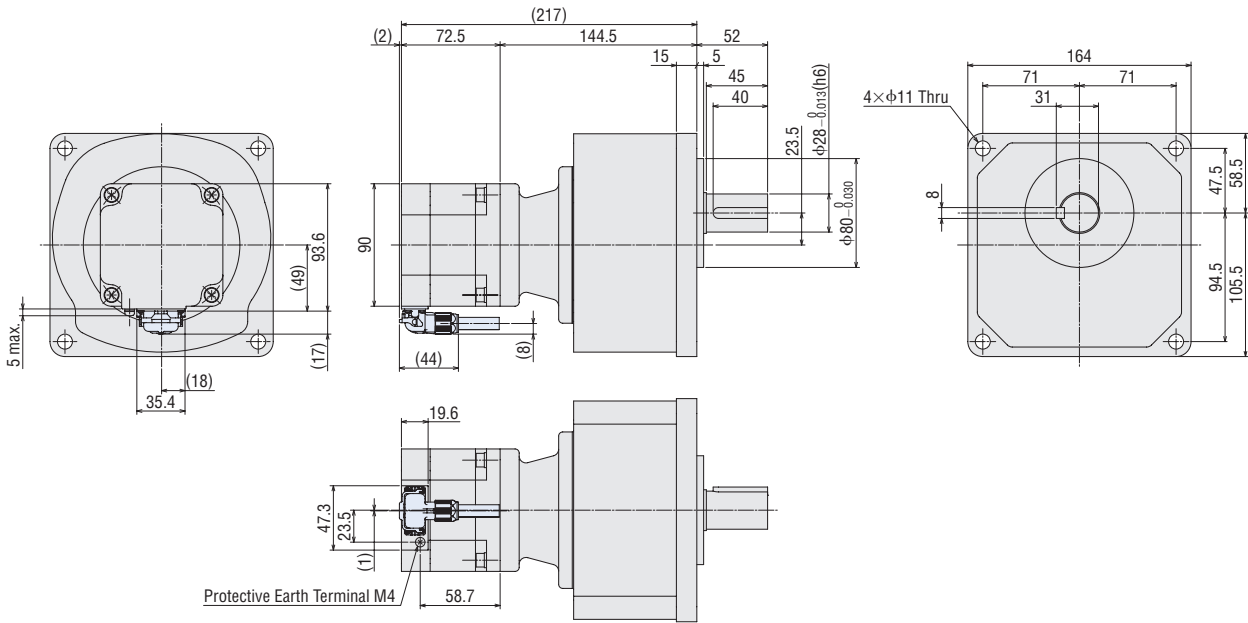

• When connecting the connection cable drawing from the counter-output shaft side

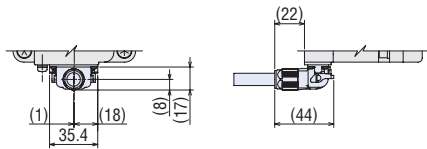

Product Name	Motor Product Name	Gearhead Product Name	Gear Ratio	Dimensions			Mass kg	2D CAD	
				A	L	B		Connection cable drawing from the output shaft side is connected	Connection cable drawing from the counter-output shaft side is connected
BLM5200HPK-5KV□S	BLM5200HPK	5KV□S	300, 450	(290.1)	61.6	47.5	12.1	A1557	A1558
BLM5400HPK-5KV□S	BLM5400HPK	5KV□S	300, 450	(301)	72.5	58.7	12.6	A1561	A1562

• When connecting the connection cable drawing from the output shaft side

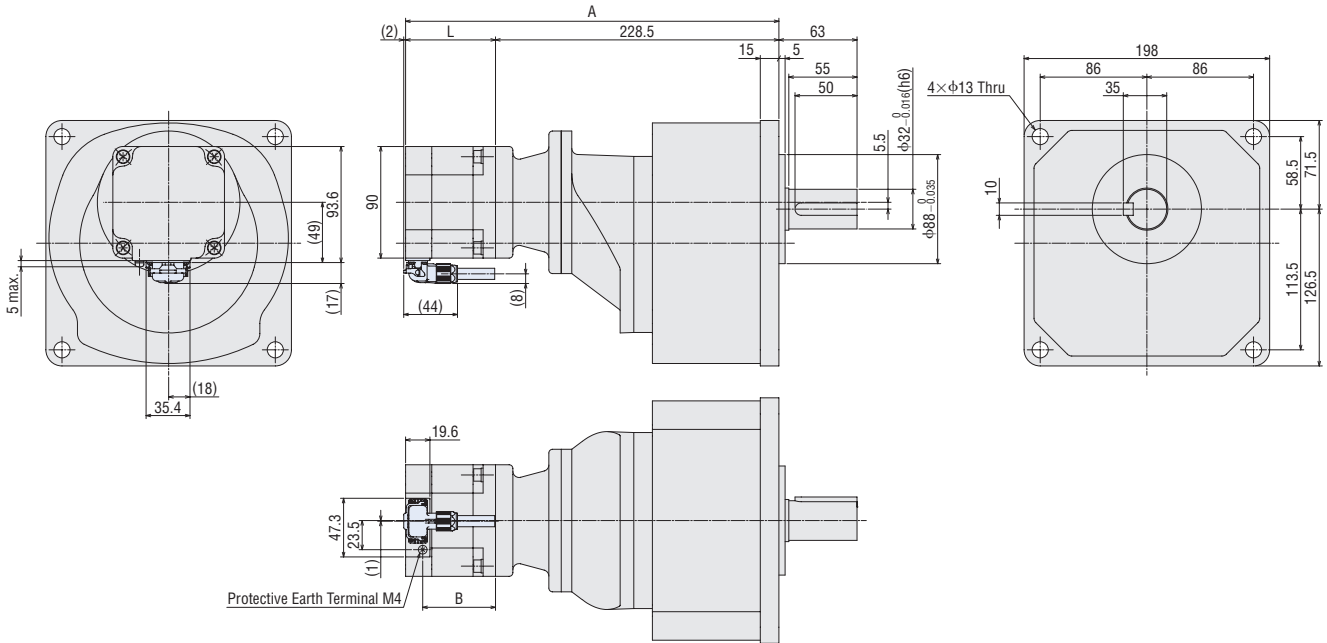

• When connecting the connection cable drawing from the counter-output shaft side

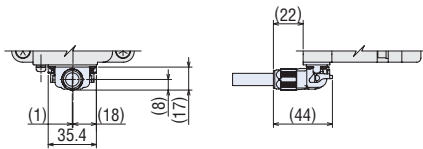

Product Name	Motor Product Name	Gearhead Product Name	Gear Ratio	Dimensions No.	L	Mass kg	2D CAD	
							Connection cable drawing from the output shaft side is connected	Connection cable drawing from the counter-output shaft side is connected
BLM5200HPK-5 ■B□B-L	BLM5200HPK	5■B□B	5, 10, 20	①	61.6	4.6	A1537	A1538
			30, 50	③		5.6	A1539	A1540
			100, 200	⑤		7.6	A1541	A1542
			300, 450	⑦		11.6	A1543	A1544
			600, 1200	⑨		18.1	A1545	A1546
BLM5400HPK-5 ■B□B-L	BLM5400HPK	5■B□B	5, 10, 20	②	72.5	5.1	A1547	A1548
			30, 50	④		6.1	A1549	A1550
			100, 200	⑥		8.1	A1551	A1552
			300, 450	⑧		12.1	A1553	A1554
			600	⑩		18.6	A1555	A1556

Dimensions No.	Total Length	Gearhead Dimensions										Output Shaft Dimensions						
		A	B	C	D	E	F	G	H	I	J	K	M	N	O	P	Q	R
①	(219.1)	157.5	85±0.2	131	110	134	φ9	40	45	64	10	φ18 _{-0.011} (h6)	16.5*	30	27	20.5	6	47.5
②	(230)																	58.7
③	(245.1)	183.5	90±0.2	139	130	154	φ11	65	55	90	12	φ22 _{-0.013} (h6)	19*	40	35	24.5	6	47.5
④	(256)																	58.7
⑤	(258.1)	196.5	110±0.2	167	140	175	φ11	90	65	125	15	φ28 _{-0.013} (h6)	23.5*	45	40	31	8	47.5
⑥	(269)																	58.7
⑦	(353.1)	291.5	130±0.2	198	170	208	φ13	130	70	168	18	φ32 _{-0.016} (h6)	5.5	55	50	35	10	47.5
⑧	(364)																	58.7
⑨	(375.1)	313.5	150±0.2	230	210	254	φ15	150	90	196	20	φ40 _{-0.016} (h6)	0	65	60	43	12	47.5
⑩	(386)																	58.7

*The center position of the gearhead output shaft is offset in an upper position than the motor's center position.

•When connecting the connection cable drawing from the output shaft side

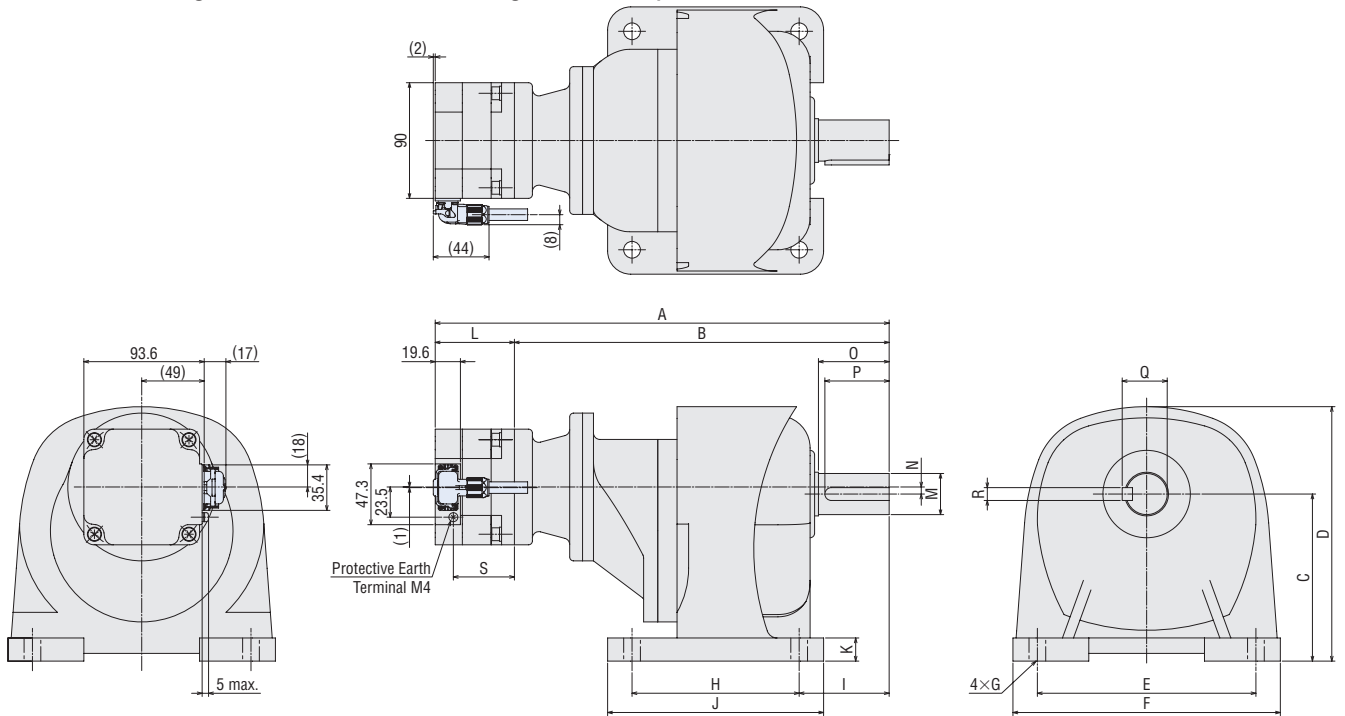

•When connecting the connection cable drawing from the counter-output shaft side

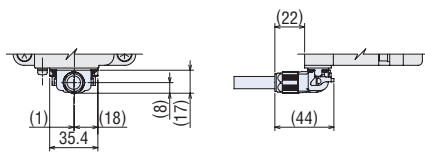

Product Name	Motor Product Name	Gearhead Product Name	Mass kg	2D CAD	
				Connection cable drawing from the output shaft side is connected	Connection cable drawing from the counter-output shaft side is connected
BLM460SHPK-4H□S	BLM460SHPK	4H□S	2.6	A1604	A1605

•When connecting the connection cable drawing from the output shaft side

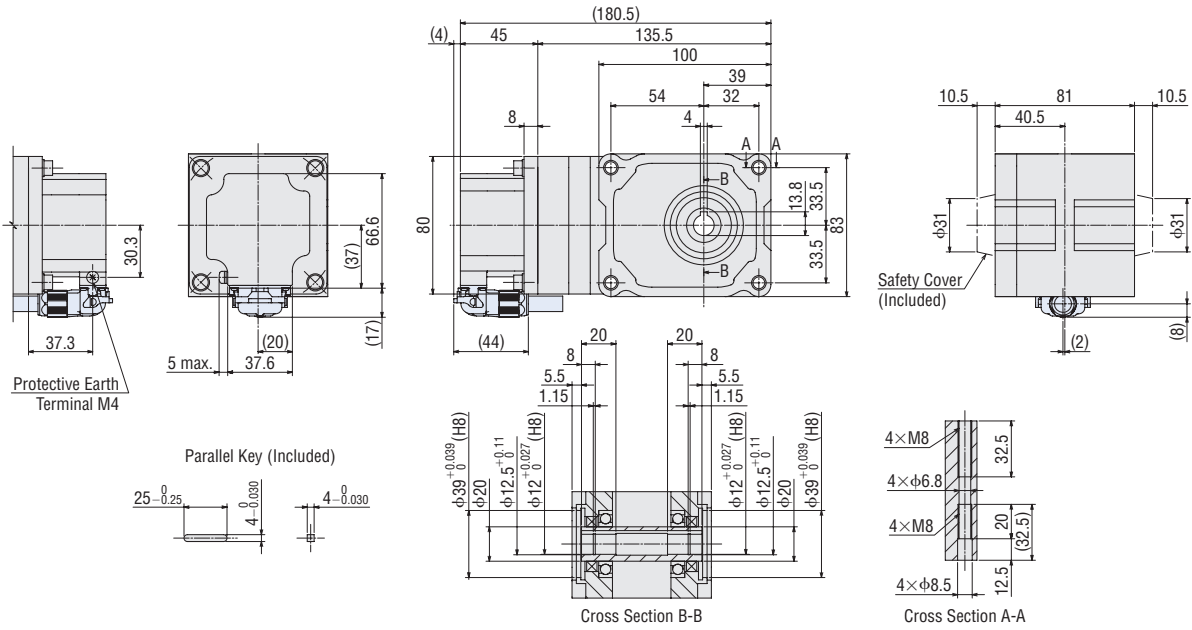

•When connecting the connection cable drawing from the counter-output shaft side

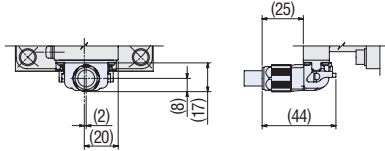

Product Name	Motor Product Name	Gearhead Product Name	Mass kg	2D CAD	
				Connection cable drawing from the output shaft side is connected	Connection cable drawing from the counter-output shaft side is connected
BLM5120HPK-5H□S	BLM5120HPK	5H□S	4.1	A1535	A1536

•When connecting the connection cable drawing from the output shaft side

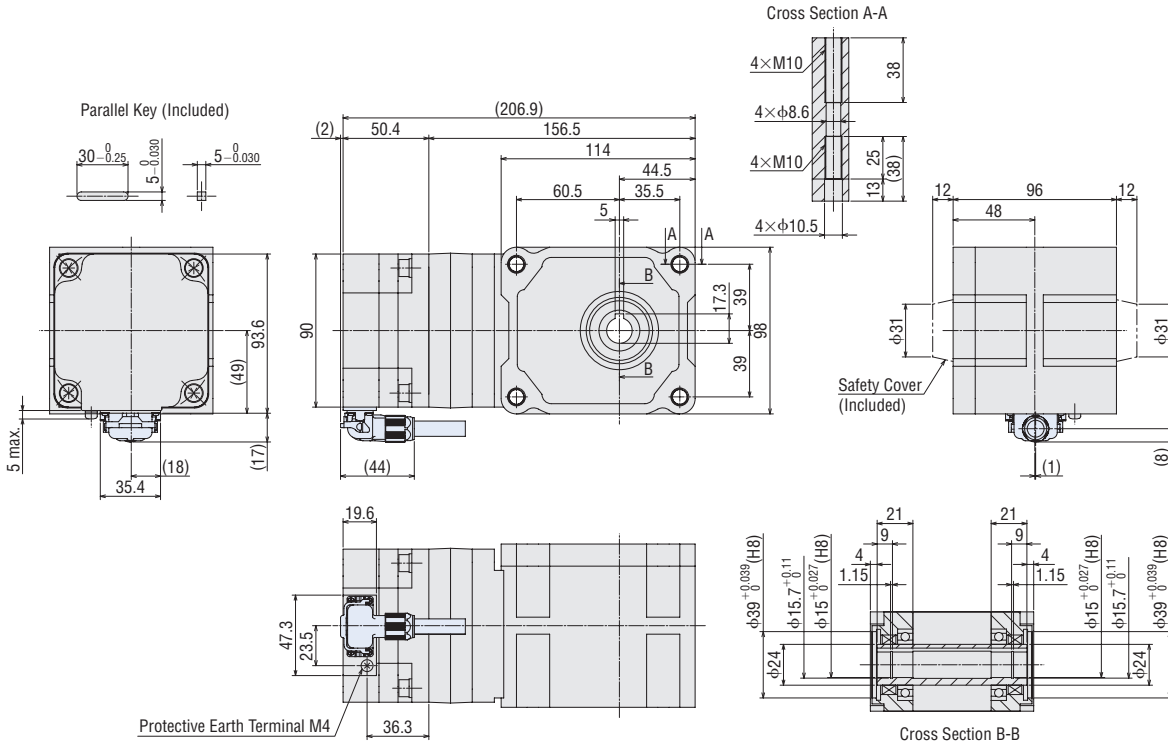

•When connecting the connection cable drawing from the counter-output shaft side

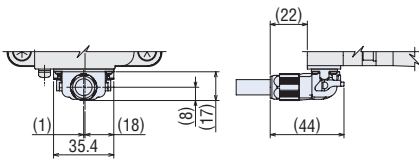

Product Name	Motor Product Name	Gearhead Product Name	Gear Ratio	Dimensions			Mass kg	2D CAD	
				C	L	D		Connection cable drawing from the output shaft side is connected	Connection cable drawing from the counter-output shaft side is connected
BLM5200HPK-5YH□S	BLM5200HPK	5YH□S	100, 200	(306.6)	61.6	47.5	8.1	A1567	A1568
BLM5400HPK-5YH□S	BLM5400HPK	5YH□S	100, 200	(317.5)	72.5	58.7	8.6	A1571	A1572

• When connecting the connection cable drawing from the output shaft side

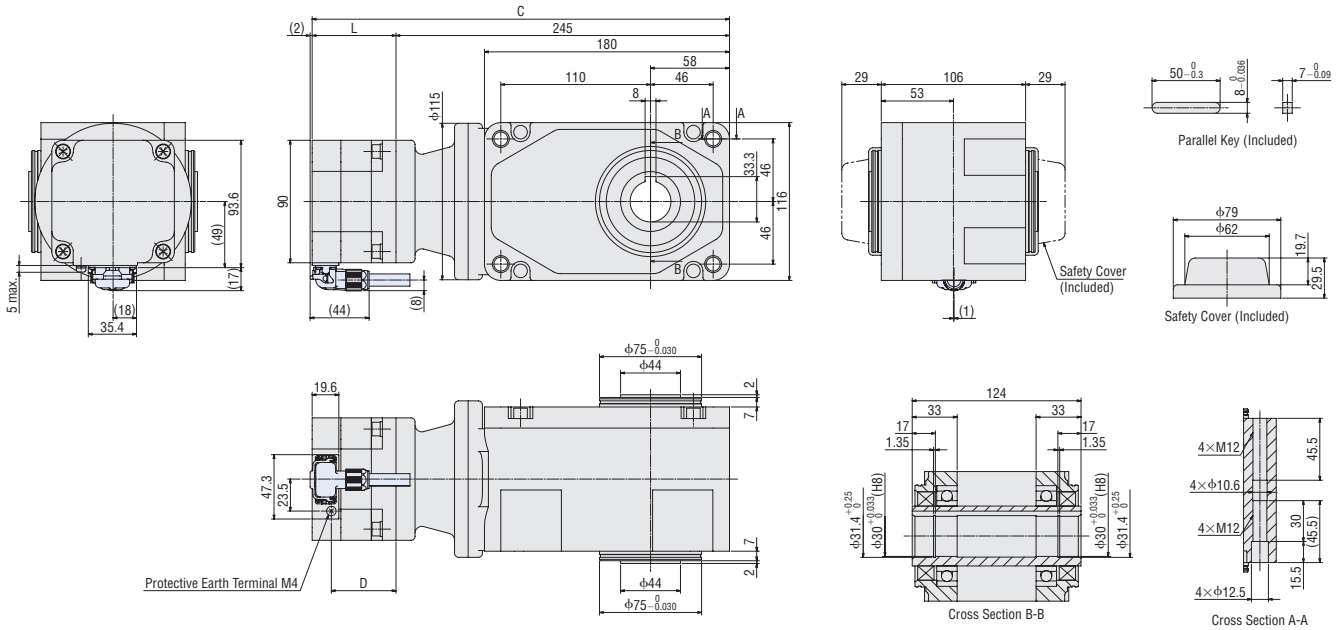

• When connecting the connection cable drawing from the counter-output shaft side

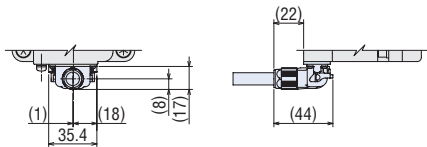

● Driver (Common among cable and connector types)

◇ 30 W, 60 W, 120 W

BMUD30-A2, BMUD30-C2, BMUD60-A2, BMUD60-C2, BMUD120-A2, BMUD120-C2

Mass: 0.4 kg

2D CAD A1359 3D CAD

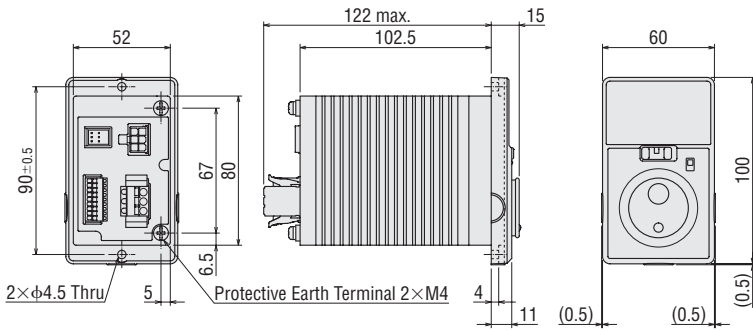

● Driver Panel Cut-out Diagram

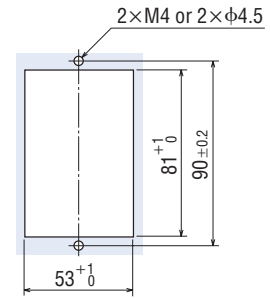

◇ 200 W, 400 W

BMUD200-A, BMUD200-C, BMUD400-S

Mass: 0.8 kg

2D CAD A1343 3D CAD

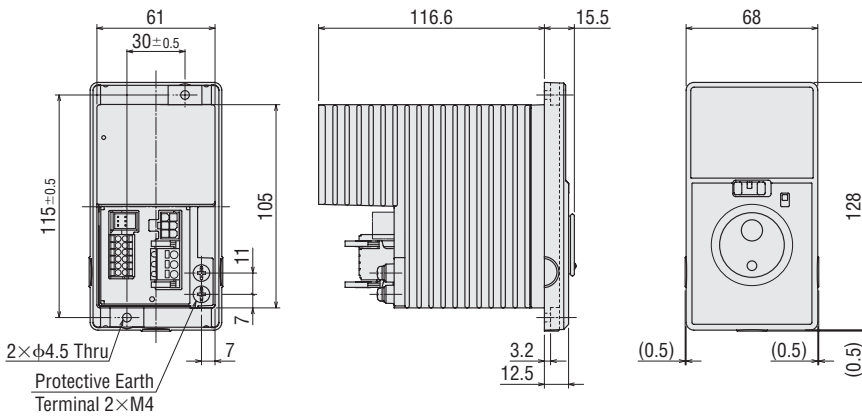

● Driver Panel Cut-out Diagram

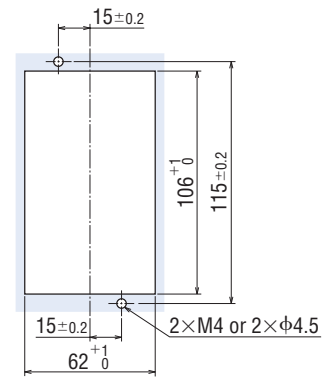

● Connection Cables (For cable type)

Product Name	Length L (m)
CC01BL2	1
CC02BL2	2
CC03BL2	3
CC05BL2	5
CC07BL2	7
CC10BL2	10

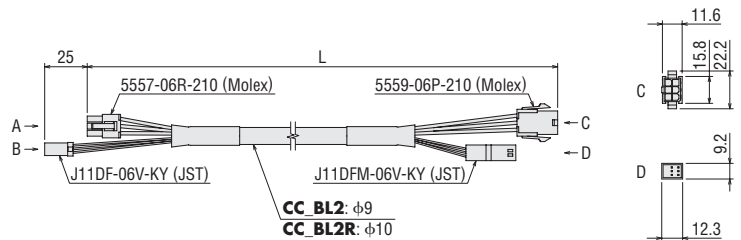
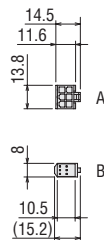

● Flexible Connection Cables (For cable type)

Product Name	Length L (m)
CC01BL2R	1
CC02BL2R	2
CC03BL2R	3
CC05BL2R	5
CC07BL2R	7
CC10BL2R	10

Driver Side

Motor Side

● Connection Cables (For connector type)

Length L (m)	Product Name		Mass (kg)
	Drawing on the output shaft side	Drawing on the counter-output shaft side	
0.5	CC005HBLF	CC005HBLB	0.08
1	CC010HBLF	CC010HBLB	0.12
1.5	CC015HBLF	CC015HBLB	0.2
2	CC020HBLF	CC020HBLB	0.25
2.5	CC025HBLF	CC025HBLB	0.32
3	CC030HBLF	CC030HBLB	0.38
4	CC040HBLF	CC040HBLB	0.49
5	CC050HBLF	CC050HBLB	0.62
7	CC070HBLF	CC070HBLB	0.86
10	CC100HBLF	CC100HBLB	1.2

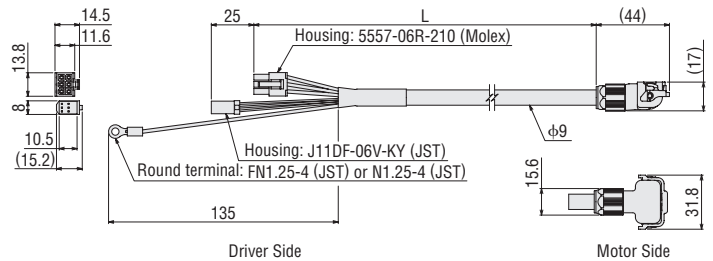

Driver Side

Motor Side

Dimensions of Installation Screws

L2 represents the length when the plain washer and the spring washer are installed on the screw head.

Parallel Shaft Gearhead

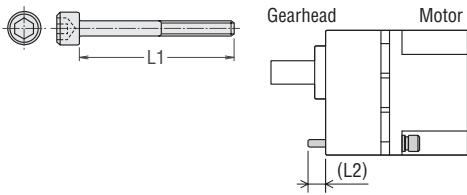

Product Name	Gear Ratio	Installation Screws		L2 (mm)
		Screw Size	L1 (mm)	
GFV2G□ GFV2G□S(F)	5~20	M4	50	6
	30~100		55	7
	200		60	7
GFV4G□ GFV4G□S(F)	5~20	M6	60	8
	30~100		65	8
	200		70	8
GFV5G□ GFV5G□S(F)	5~20	M8	70	11.5
	30~100		85	13.5
	200		90	12.5
GFV6G□ GFV6G□S	5~20	M8	85	11
	30, 50		100	14
	100, 200		110	10

● Installation screw: Includes 4 plain washers and 4 spring washers each.
The installation screw material is stainless steel.

Hypoid Right-Angle Hollow Shaft

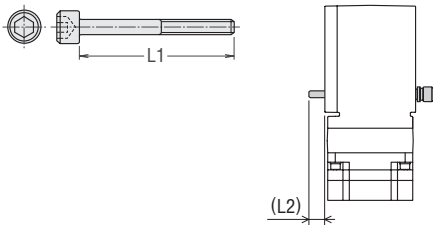

Product Name	Gear Ratio	Installation Screws		L2 (mm)
		Screw Size	L1 (mm)	
4H□S	10~200	M6	95	11
5H□S	10~200	M8	110	10
5XH□S	5~50	M8	120	16
5YH□S	100, 200	M10	130	19.5

● Installation screw: Includes 4 plain washers and 4 spring washers each.
The installation screw material is stainless steel.

● A number in the box □ in the product name indicates the gear ratio.

Connection and Operation (30 W, 60 W, 120 W)

Names and Functions of Driver Parts

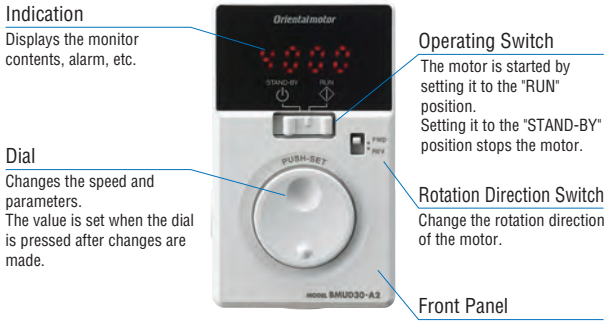

Front side of the driver

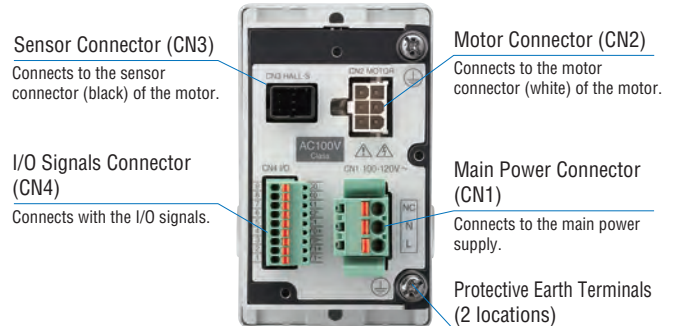

Back side of the driver

When Front Panel is Removed

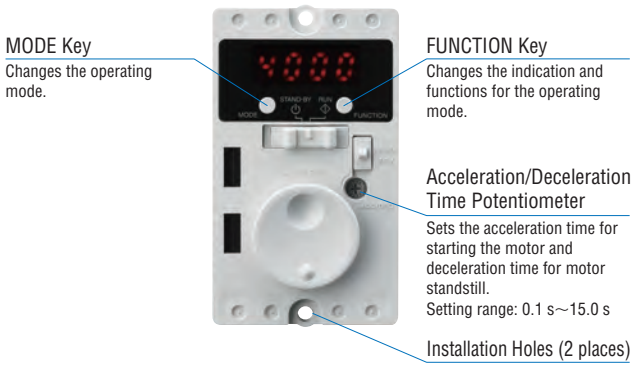

Extended Functions

Remove the front panel to be able to perform various settings by operating the keys.

Operating Mode	Details
Monitoring	Rotation speed, load factor, operating data No., alarm, warning, I/O monitor
Data	Data 4 points Rotation speed, acceleration time, deceleration time, reset
Parameters	Gear ratio, speed increasing ratio, initial panel indication, initial operation inhibition alarm, prohibition alarm of operation at the initial setting release method selection, analog acceleration/deceleration, upper and lower limits of speed setting function, easy holding function, external operating signal input, input function selection, output function selection, overload alarm detection time except during axial lock, overload warning level, speed attainment width, parameter mode reset

Main Power Connector (CN1)

Connects to the main power supply. Connect a power supply that matches with the power supply voltage to be used.

•Single-Phase 100-120 VAC

•Single-Phase 200-240 VAC

•Three-Phase 200-240 VAC

•Applicable Lead Wire Size
AWG18~14 (0.75~2.0 mm²)

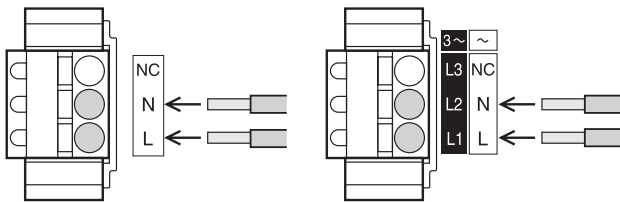

Operation with the Driver only

Run/Stop

When the operating switch is set to the "RUN" position, the motor will start.
When it is returned to the "STAND-BY" position, the motor decelerates to a stop.

Speed Setting Method

Set the motor speed by using the dial.

Turning the dial slowly to the right increases the speed by 1 r/min increments, while turning it to the left reduces the speed by 1 r/min increments.

Turning the dial fast produces a great variation in speed.

Pressing the dial sets the speed.

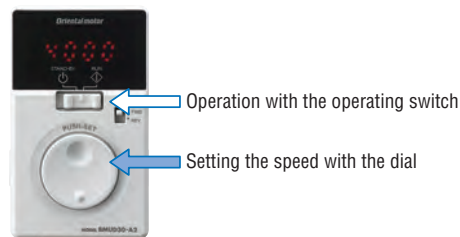

Operating Switch



● Operation by External Signals

◇ Operating Method

- Using the built-in power supply in the driver, the motor is operated through external signals (switched, relays, etc.).
Connect Pins No. 5~8 of the I/O signal connector (CN4) as in the figure to the right.
- For operation using external signals, change the parameter setting in the "External Operating Signal Input". For details, see the user's guide.
- Multiple speed operation is available in up to 4 levels.

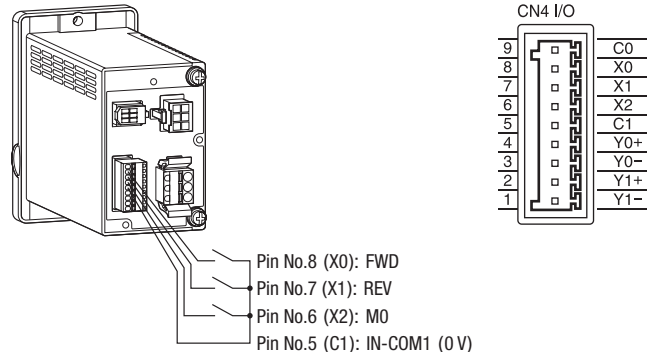

- Pin No.8 (X0): FWD
- Pin No.7 (X1): REV
- Pin No.6 (X2): MO
- Pin No.5 (C1): IN-COM1 (0 V)

● I/O Signals Connector (CN4)

Pin No.	Terminal Name	Functions*	Description
9	C0	Input signal common (for external power supply)	Connect for external power supplies.
8	X0	[FWD]	During "ON", the motor rotates in the FWD direction.
7	X1	[REV]	During "ON", the motor rotates in the REV direction.
6	X2	[MO]	Select the operating data.
5	C1	0V (for internal power supply)	Connect for internal power supply.
4	Y0+	[SPEED-OUT]	For every rotation of the motor output shaft, 30 pulses are output.
3	Y0-		
2	Y1+	[ALARM-OUT1]	It turns OFF when an alarm is generated. (Normally closed)
1	Y1-		

*The [] indicates the functions assigned in the factory.

Among the following signals, the signals required for the 3 input signal terminals (X0~X2) and the 2 output signal terminals (Y0, Y1) can be assigned.

3 points for the 7 input signal points (FWD, REV, MO, M1, ALARM-RESET, EXT-ERROR, H-FREE)

2 points for the 6 input signal points (ALARM-OUT1, SPEED-OUT, ALARM-OUT2, MOVE, VA, WNG)

● Applicable Lead Wire Size

AWG26~20 (0.14~0.5 mm²)

◇ Connection Diagram

The diagrams are for a Single-Phase 100-120 VAC. I/O signals specified in [] are factory set signals.

● When using the built-in power supply

The figure shows a connection example for the operation of the motor using switches having contacts, such as switches or relays.

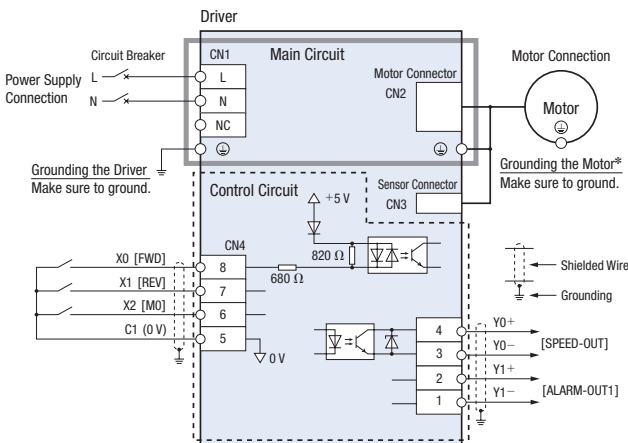

*Grounding the motor

For the connector type: Motor cables may not satisfy the grounding resistance of the standard applied to the equipment depending on the type or the length.

To resolve this issue, make sure to install the motor close to the ground.

For the cable type: The motor cable does not have a protective earth wire. Make sure to ground using the protective earth terminal for the motor.

● When using external power supply

The figure shows a connection example when the motor is operated in a sequential connection with transistors.

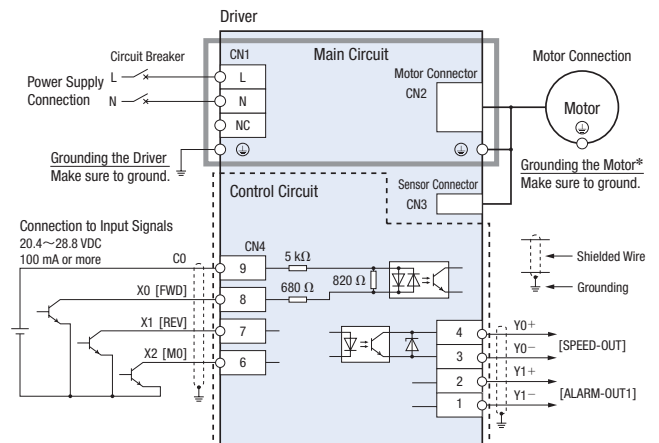

◇ Timing Chart

This is a timing chart when the "External operating signal input" parameter is set to "ON" and the rotation direction switch to "FWD".

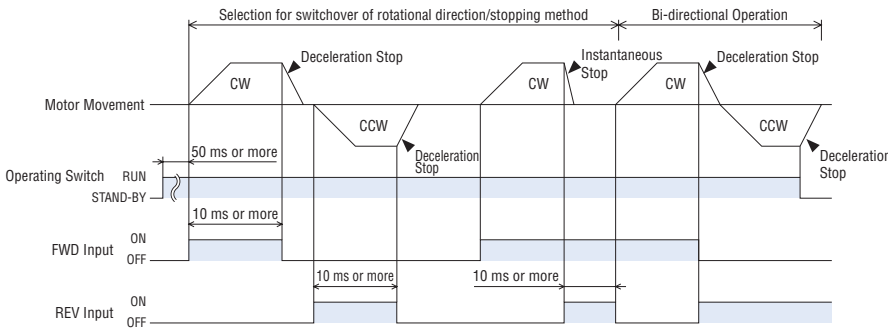

- Switching the FWD input to ON will cause the motor to turn clockwise as viewed from the motor shaft side, while switching the REV input to ON will cause the motor to turn counterclockwise. Turning it OFF decelerates the motor to a stop.
- If both the FWD input and REV input are turned ON simultaneously, the motor will stop instantaneously.
- The rotation direction varies depending on the gear ratio of the gearhead.

◇ Example of Connection of I/O Signals with the Host Controller

This is a connection example for the operation of the motor using the host controller of the transistor output type.

● Sink Logic

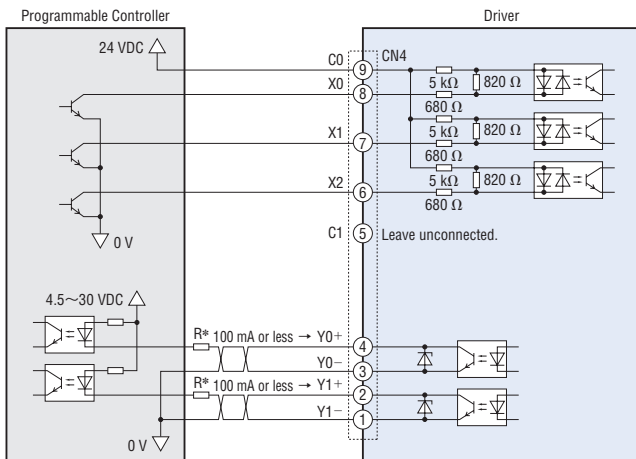

● Source Logic

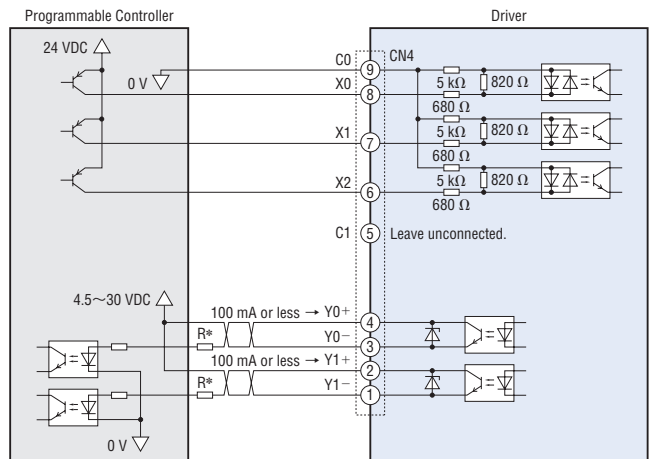

*Recommended resistance Value
 For 24 VDC: 680 Ω~2.7 kΩ (2 W)
 For 5 VDC: 150 Ω~560 Ω (0.5 W)

Note

The current applied to Y0 and Y1 must be 100 mA or less. If this value is exceeded, connect the limiting resistance R.

◇ When an External Control Equipment with a Built-in Clamp Diode is used

With external control equipment with built-in clamping diodes connected, if the power of the external control equipment is turned off with the driver turned on, the motor may rotate due to current flowing around. The motor may also rotate even if the driver and the external control equipment are simultaneously turned ON/OFF because these two devices have different current capacities.

To turn off the power, first turn off the driver and then the external control equipment.
 To turn on the power, first turn on the external control equipment and then the driver.

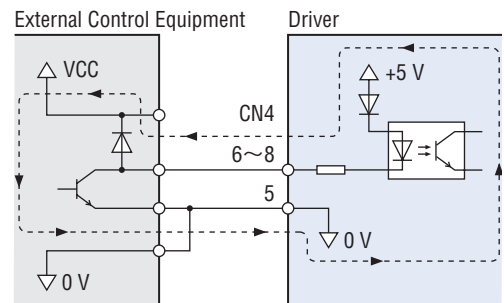

◇ When using for the Multiple Speed Operation

By switching the ON/OFF of the M0 or M1 input, the multiple speed operation becomes available.

● Example of operating conditions

Operating Data No.	M0	M1	Speed [r/min]
0	OFF	OFF	3000
1	ON	OFF	1000
2	OFF	ON	2000
3	ON	ON	500

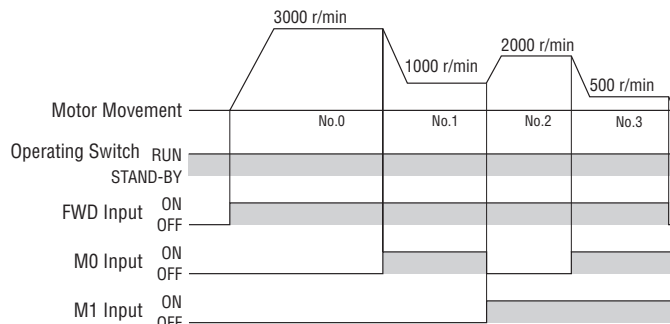

Connection and Operation (200 W, 400 W)

Names and Functions of Driver Parts

Indication

Displays the monitor contents, alarm, etc.

Dial

Changes the speed and parameters. The value is set when the dial is pressed after changes are made.



Front side of the driver

Operating Switch

The motor is started by setting it to the "RUN" position. Setting it to the "STAND-BY" position stops the motor.

Rotation Direction Switch

Change the rotation direction of the motor.

Front Panel



Back side of the driver

Sensor Connector (CN3)

Connects to the sensor connector (black) of the motor.

I/O Signal Connector (CN4)

Connects with the I/O signals.

Motor Connector (CN2)

Connects to the motor connector (white) of the motor.

Main Power Connector (CN1)

Connects to the main power supply.

Protective Earth Terminals (2 locations)

Ground either one of the protective earth terminals.

When Front Panel is Removed

MODE Key

Changes the operating mode.



FUNCTION Key

Changes the indication and functions for the operating mode.

Acceleration/Deceleration Time Potentiometer

Sets the acceleration time for starting the motor and deceleration time for motor standstill. Setting range: 0.1 s~15.0 s

Installation Holes (2 places)

Extended Functions

Remove the front panel to be able to perform various settings by operating the keys.

Operating Mode	Details
Monitoring	Rotation speed, load factor, operation data No., alarm, warning, I/O monitor
Data	Data 4 points Rotation speed, acceleration time, deceleration time, reset
Parameters	Gear ratio, speed increasing ratio, initial panel indication, initial operation inhibition alarm, prohibition alarm of operation at the initial setting release method selection, analog acceleration/deceleration, upper and lower limits of speed setting function, easy holding function, external operating signal input, input function selection, output function selection, overload alarm detection time except during axial lock, overload warning level, speed attainment width, parameter mode reset

Main Power Connector (CN1)

Connects to the main power supply. Connect a power supply that matches with the power supply voltage to be used.

•Single-Phase 100-120 VAC

•Single-Phase 200-240 VAC

•Three-Phase 200-240 VAC

•Applicable Lead Wire Size
AWG18~14 (0.75~2.0 mm²)

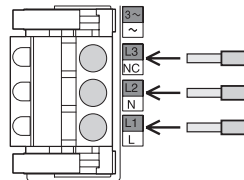
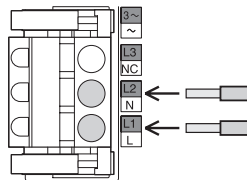
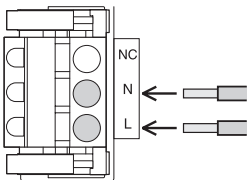

For the 400 W type, L1, L2 and L3 displays only.

Operation with the Driver only

Run/Stop

When the operating switch is set to the "RUN" position, the motor will start. When it is returned to the "STAND-BY" position, the motor decelerates to a stop.

Speed Setting Method

Set the motor speed by using the dial.

Turning the dial slowly to the right increases the speed by 1 r/min increments, while turning it to the left reduces the speed by 1 r/min increments.

Turning the dial fast produces a great variation in speed.

Pressing the dial sets the speed.



Operation with the operating switch

Setting the speed with the dial

Operating Switch



● Operation by External Signals

◇ Operating Method

- Using the built-in power supply in the driver, the motor is operated through external signals (switched, relays, etc.). Connect Pins No. 1~5 and No. 7 of the I/O signal connector (CN4) as in the table below.
- For operation using external signals, change the parameter setting in the "External Operating Signal Input". For details, see the user's guide.
- Multiple speed operation is available in up to 4 levels.

● I/O Signals Connector (CN4)

Pin No.	Signal Name	Functions*	Description
1	IN4	[ALARM-RESET]	Alarms are reset.
2	IN3	[M1]	Select the operating data.
3	IN2	[M0]	
4	IN1	[REV]	During "ON", the motor rotates in the REV direction.
5	IN0	[FWD]	During "ON", the motor rotates in the FWD direction.
6	IN-COM0	Input signal common (for external power supply)	Connect for external power supplies.
7	IN-COM1	0V (for internal power supply)	Connect for internal power supply.
8	N.C.	N.C.	Leave unconnected.
9	OUT1-	[ALARM-OUT1]	It turns OFF when an alarm is generated. (Normally closed)
10	OUT1+		
11	OUT0-	[SPEED-OUT]	For every rotation of the motor output shaft, 30 pulses are output.
12	OUT0+		

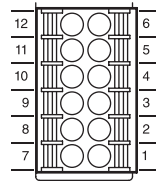

CN4

● Applicable Lead Wire Size

AWG24~18 (0.2~0.75 mm²)

*The [] indicates the functions assigned in the factory.

Among the following signals, the signals required for the 5 input signal terminals (IN0~IN4) and the 2 output signal terminals (OUT0, OUT1) can be assigned.

5 points for the 7 input signal points (FWD, REV, M0, M1, ALARM-RESET, EXT-ERROR, H-FREE)

2 points for the 6 input signal points (ALARM-OUT1, SPEED-OUT, ALARM-OUT2, MOVE, VA, WNG)

◇ Connection Diagram

The diagrams are for a Single-Phase 100-120 VAC. I/O signals specified in [] are factory set signals.

● When using the built-in power supply

The figure shows a connection example for the operation of the motor using switches having contacts, such as switches or relays.

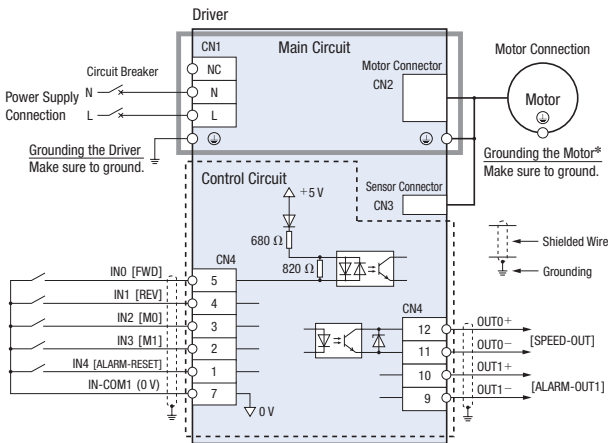

*Grounding the motor

For the connector type: Motor cables may not satisfy the grounding resistance of the standard applied to the equipment depending on the type or the length.

To resolve this issue, make sure to install the motor close to the ground.

For the cable type: The motor cable does not have a protective earth wire. Make sure to ground using the protective earth terminal for the motor.

● When using external power supplies

The figure shows a connection example when the motor is operated in a sequential connection with transistors.

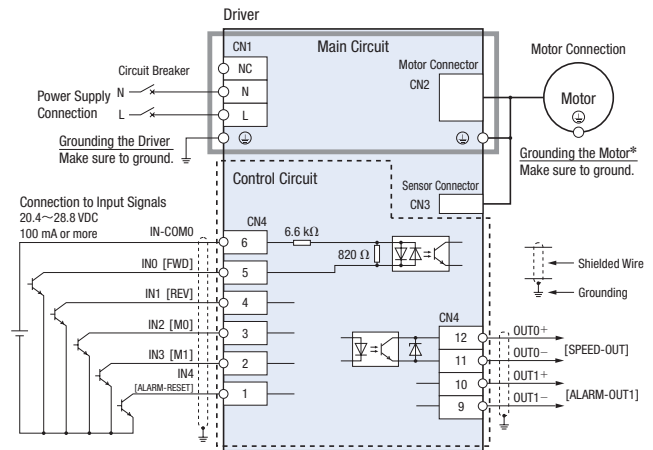

◇ Timing Chart

This is a timing chart when the "External operating signal input" parameter is set to "ON" and the rotation direction switch to "FWD".

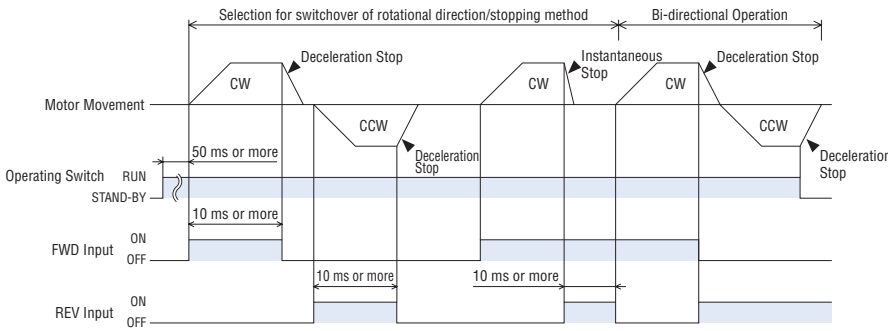

- Switching the FWD input to ON will cause the motor to turn clockwise as viewed from the motor shaft side, while switching the REV input to ON will cause the motor to turn counterclockwise. Turning it OFF decelerates the motor to a stop.
- If both the FWD input and REV input are turned ON simultaneously, the motor will stop instantaneously.
- The rotation direction varies depending on the gear ratio of the gearhead.

◇ Example of Connection of I/O Signals with the Host Controller

This is a connection example for the operation of the motor using the host controller of the transistor output type.

● Sink Logic

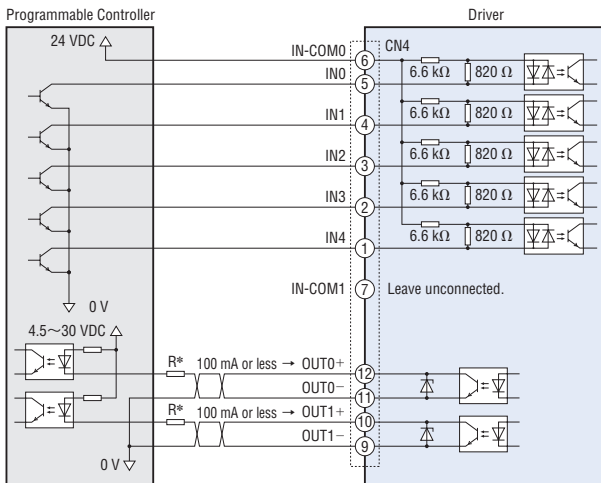

● Source Logic

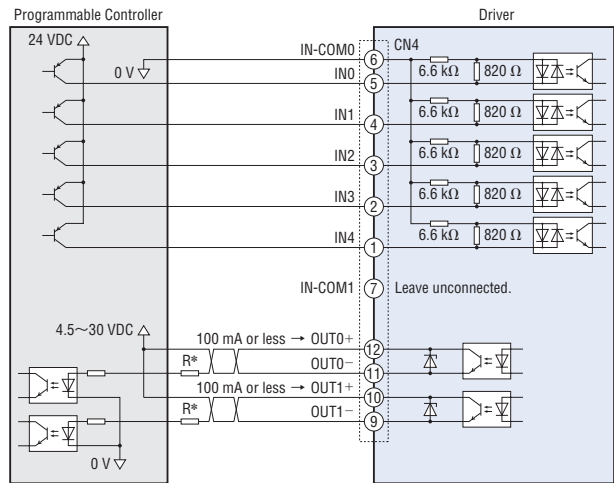

*Recommended resistance Value
 For 24 VDC: 680 Ω~2.7 kΩ (2 W)
 For 5 VDC: 150 Ω~560 Ω (0.5 W)

Note

The current applied to OUT0 and OUT1 must be 100 mA or less. If this value is exceeded, connect the limiting resistance R.

◇ When an External Control Equipment with a Built-in Clamp Diode is used

With external control equipment with built-in clamping diodes connected, if the power of the external control equipment is turned off with the driver turned on, the motor may rotate due to current flowing around. The motor may also rotate even if the driver and the external control equipment are simultaneously turned ON/OFF because these two devices have different current capacities.

To turn off the power, first turn off the driver and then the external control equipment.
 To turn on the power, first turn on the external control equipment and then the driver.

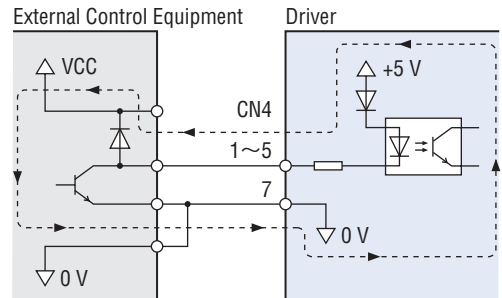

◇ When using for the Multiple Speed Operation

By switching the ON/OFF of the M0 or M1 input, the multiple speed operation becomes available.

● Example of operating conditions

Operating Data No.	M0	M1	Speed [r/min]
0	OFF	OFF	3000
1	ON	OFF	1000
2	OFF	ON	2000
3	ON	ON	500

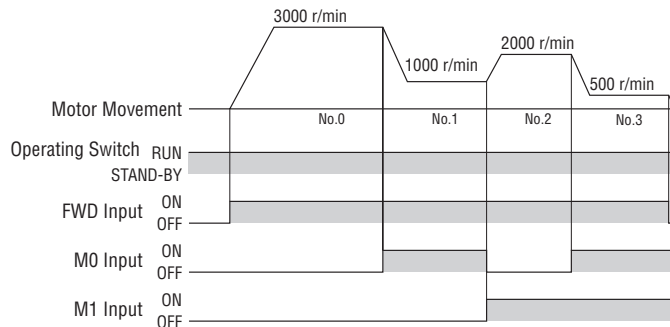

Installation of Hollow Shaft Load

● Example of Load Shaft Installation Method

The load installation method differs depending on the shape of the load shaft. See the figures below.

- The hollow output shaft is processed to a tolerance of the inner diameter H8, and incorporates a key slot for load shaft installation.
- The recommended tolerance of the load shaft is h7.

Note

- To prevent sticking, apply a coat of grease on the exterior surface of the load shaft and interior surface of the hollow output shaft.

◇ Stepped Load Shaft

● Fixing method using the end plate

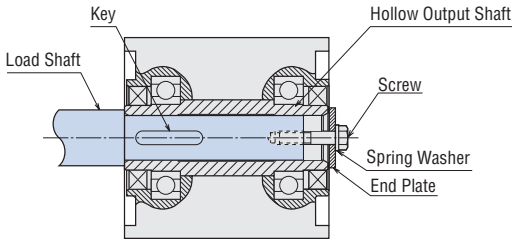

● Fixing method using the retaining ring for hole

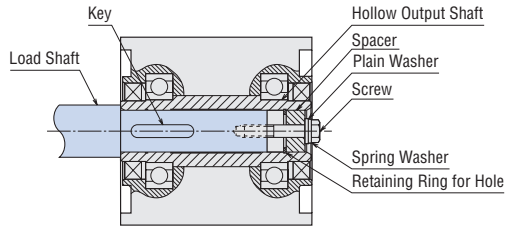

◇ For Non-Stepped Load Shaft

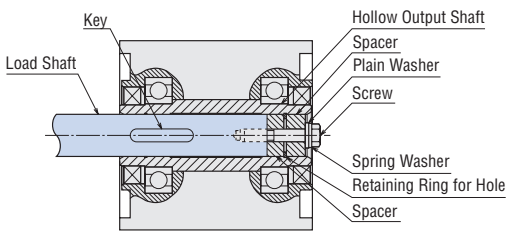

◇ Recommended Load Shaft Installation Method

Unit: mm

Output Power	60 W	120 W	200 W, 400 W	
Gear Ratio	10~200	10~200	5~50	100, 200
Inner Diameter of Hollow Output Shaft (H8)	$\phi 12^{+0.027}_0$	$\phi 15^{+0.027}_0$	$\phi 25^{+0.033}_0$	$\phi 30^{+0.033}_0$
Recommended Tolerance of Load Shaft (h7)	$\phi 12^0_{-0.018}$	$\phi 15^0_{-0.018}$	$\phi 25^0_{-0.021}$	$\phi 30^0_{-0.021}$
Screw Size	M5	M6	M6	M8
Spacer Dimensions	Outer Diameter	$\phi 11.5$	$\phi 14.5$	$\phi 24.5$
	Inner Diameter	$\phi 6$	$\phi 7$	$\phi 7$
	Width	3	3	4
Nominal Hole Diameter of Retaining Ring (C type retaining ring)	$\phi 12$	$\phi 15$	$\phi 25$	$\phi 30$
End Plate Thickness	3	3	4	5
Stepped Shaft La length	55	72	96	96

- Retaining rings for holes, spacers, screws or other parts used to install the load shaft are not supplied.

◇ Recommended Load Shaft Length

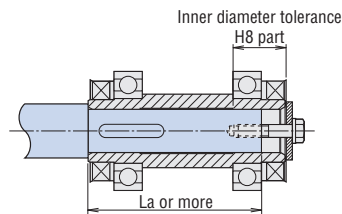

● Permissible Radial Load Calculation of the Hollow Shaft Type

Formulas to calculate permissible radial loads vary depending on the mechanism.

◇ When One End of the Load Shaft is Not Supported by a Bearing Unit

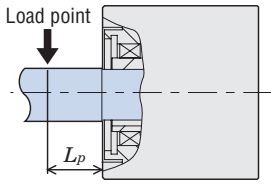

● 60 W

$$\text{Permissible Radial Load } W [\text{N}] = \frac{68.5}{48.5 + L_p} \times F_0$$

● 120 W

$$\text{Permissible Radial Load } W [\text{N}] = \frac{79}{59 + L_p} \times F_0$$

● 200 W, 400 W (Gear ratio **5~50**)

$$\text{Permissible Radial Load } W [\text{N}] = \frac{95.5}{75.5 + L_p} \times F_0$$

● 200 W, 400 W (Gear ratio **100, 200**)

$$\text{Permissible Radial Load } W [\text{N}] = \frac{102}{82 + L_p} \times F_0$$

◇ When One End of the Load Shaft is Supported by a Bearing Unit

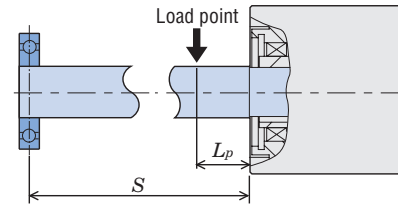

● 60 W

$$\text{Permissible Radial Load } W [\text{N}] = \frac{68.5(S+5.5)}{53(S-L_p)} \times F_0$$

● 120 W

$$\text{Permissible Radial Load } W [\text{N}] = \frac{79(S+4)}{65(S-L_p)} \times F_0$$

● 200 W, 400 W (Gear ratio **5~50**)

$$\text{Permissible Radial Load } W [\text{N}] = \frac{95.5(S-9)}{104.5(S-L_p)} \times F_0$$

● 200 W, 400 W (Gear ratio **100, 200**)

$$\text{Permissible Radial Load } W [\text{N}] = \frac{102(S-9)}{111(S-L_p)} \times F_0$$

F_0 [N]: Permissible radial load when the reference point is at 20 mm from the installation surface.

L_p [mm]: Distance from the installation surface to the load point.

S [mm]: Distance from the installation surface to the bearing unit.

● For details on the permissible radial load when the reference position is 20 mm away from the flange installation surface, see the Specifications table. → Pages 22 and 24