



2-3 QH Series – Quiet Linear Guideway, with SynchMotion™ Technology

The development of LIMON-QH linear guideway is based on a four-row circular-arc contact. The LIMON-QH series linear guideway with SynchMotion™ Technology offers smooth movement, superior lubrication, quieter operation and longer running life. Therefore the LIMON-QH linear guideway has broad industrial applicability. In the high-tech industry where high speed, low noise, and reduced dust generation is required, the LIMON-QH series is interchangeable with the LIMON-H series.

2-3-1 Features of QH Series

(1) Low Noise Design

With SynchMotion™ technology, rolling elements are interposed between the partitions of SynchMotion™ to provide improved circulation. Due to the elimination of contact between the rolling elements, collision noise and sound levels are drastically reduced.

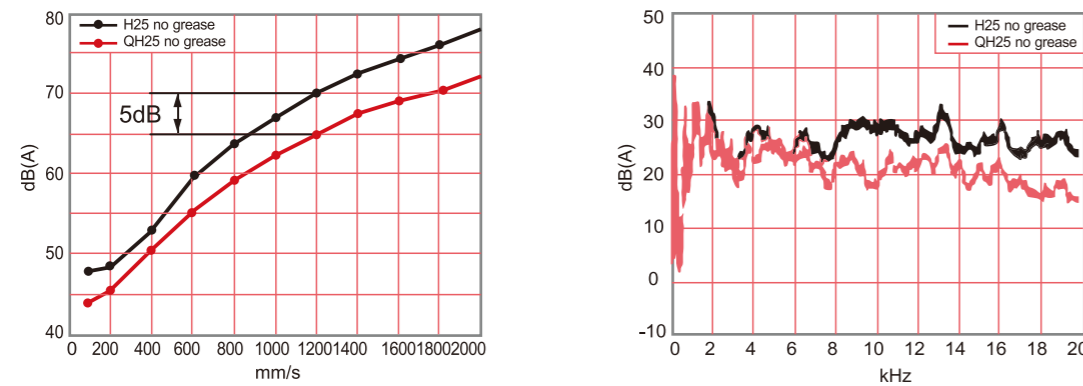

(2) Self-Lubricant Design

The partition is a grouping of hollow ring-like structures formed with a through hole to facilitate circulation of the lubricant. Because of the special lubrication path design, the lubricant of the partition storage space can be refilled. Therefore, the frequency of lubricant refilling can be decreased. The QH-series linear guideway is pre-lubricated. Performance testing at a 0.2C (basic dynamic load) shows that after running 4,000km no damage was apparent to either the rolling elements or the raceway.

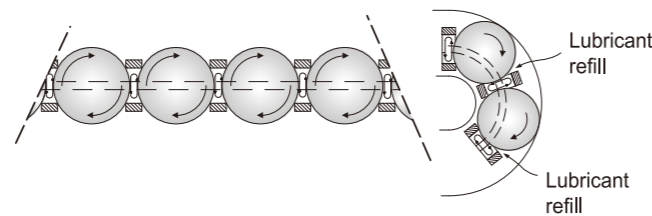

(3) Smooth Movement

In standard linear guideways, rolling elements on the load side of the guide block begin rolling and push their way through the raceway. When they contact other rolling elements they create counter-rotational friction. This results in a great variation of rolling resistance. The QH linear guideway, with SynchMotion™ technology prevents this condition. As the block starts to move, the rolling elements begin rolling consecutively and remain separated to prevent contact with one another thus keeping the element's kinetic energy extremely stable in order to effectively reduce fluctuations in rolling resistance.

(4) High Speed Performance

The LIMON-QH series offers excellent high-speed performance due to the partitions of the SynchMotion™ structure. They are employed to separate the adjacent balls thereby resulting in low rolling traction and the metallic friction between adjacent balls is eliminated.

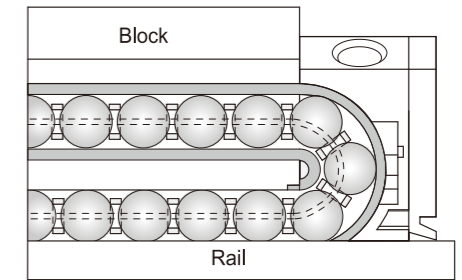

2-3-2 Construction of QH Series

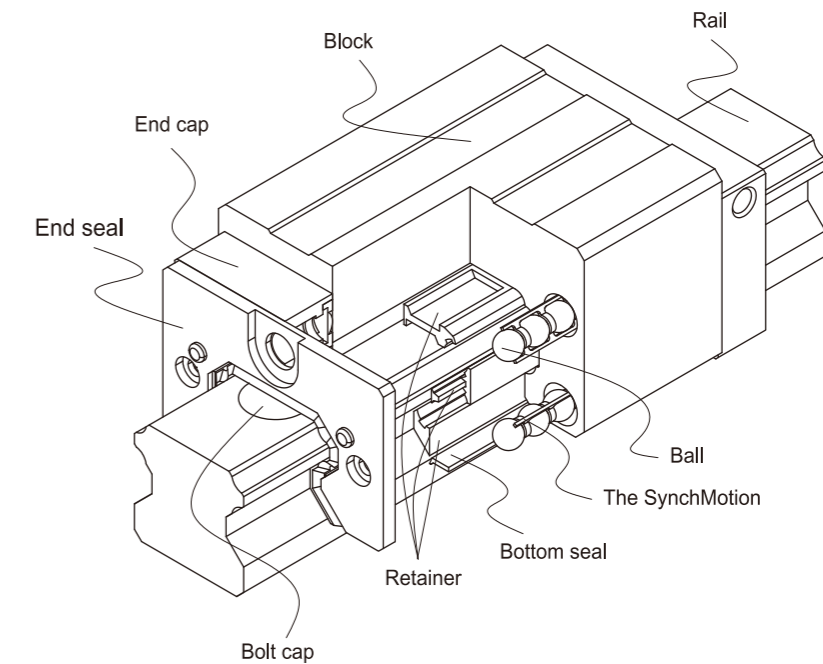

2-3-3 Model Number of QH Series

LIMON-QH series guideway can be classified into non-interchangeable and interchangeable types. The sizes are identical. The main difference is that the interchangeable blocks and rails can be freely exchanged. Because of dimensional control, the interchangeable type linear guideway is a perfect choice for the client when rails do not need to be paired for an axis. And since the QH and H share the identical rails, the customer does not need to redesign when choosing the QH series. Therefore the LIMON-QH linear guideway has increased applicability.



(1) Non-interchangeable type

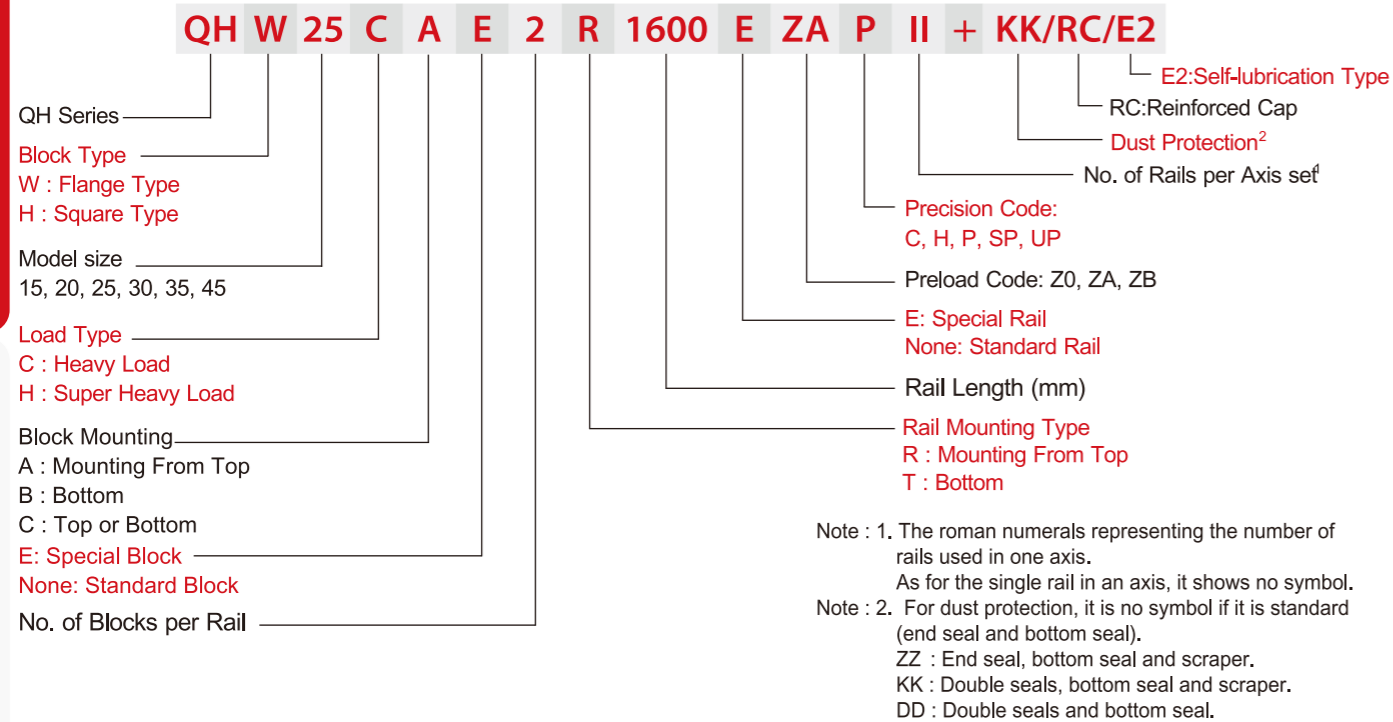

(2) Interchangeable type

□ Model Number of QH Block

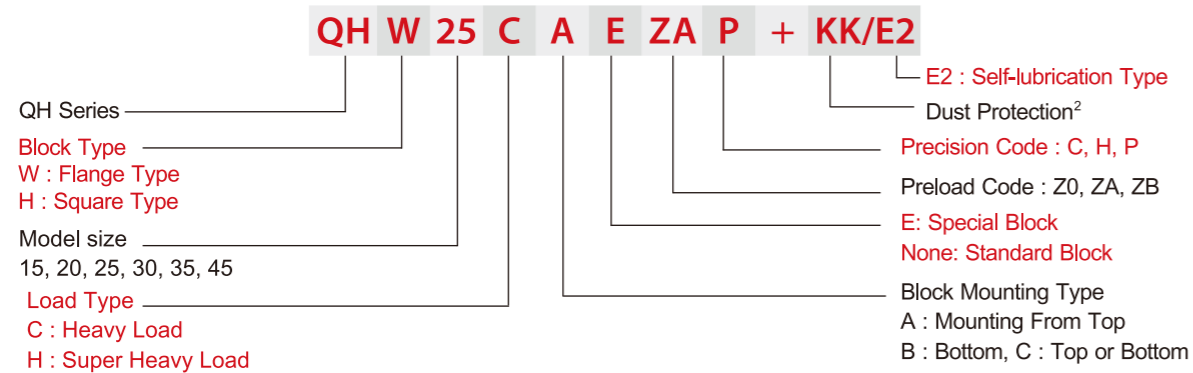

□ Model Number of QH Rail (QH and H share the identical rails)

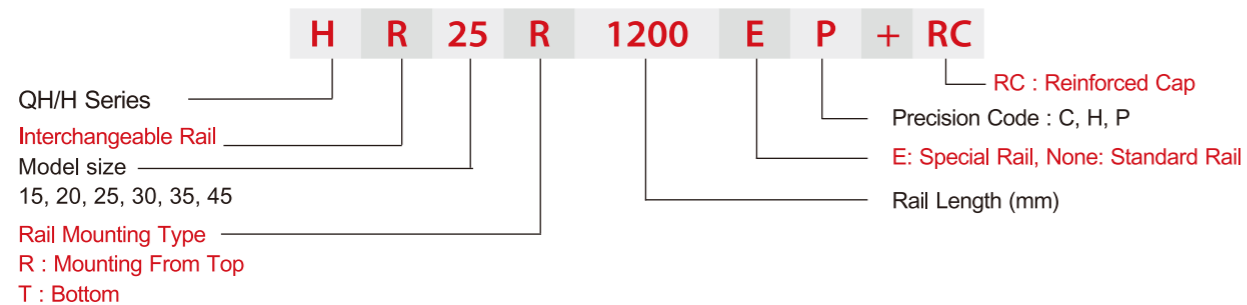

2-3-4 Types

(1) Block types

LIMON offers two types of linear guideways, flange and square types.

Table 2-3-1 Block Types

Type	Model	Shape	Height (mm)	Rail Length (mm)	Main Applications
Square	QHH-CA QHH-HA		28	100	<input type="checkbox"/> Automation devices <input type="checkbox"/> High-speed transportation equipment <input type="checkbox"/> Precision measuring equipment <input type="checkbox"/> Semiconductor manufacturing equipment
			70	4000	
Flange	QHW-CA QHW-HA		24	100	
			60	4000	
			24	100	
			60	4000	
Flange	QHW-CB QHW-HB		24	100	
			60	4000	
Flange	QHW-CC QHW-HC		24	100	
			60	4000	

(2) Rail types

Besides the standard top mounting type, the bottom mounting type is also available.

Table 2-3-2 Rail Types





2-3-5 Accuracy

The accuracy of QH series can be classified into normal (C), high (H), precision (P), super precision (SP), ultra precision (UP), five classes. Please choose the class by referring the accuracy of applied equipment.

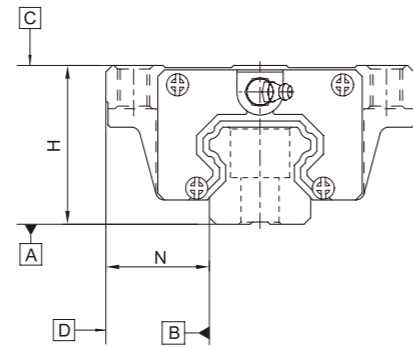

(1) Accuracy of non-interchangeable

Table 2-3-3 Accuracy Standards

Unit: mm

Item	QH - 15, 20				
	Normal (C)	High (H)	Precision (P)	Super Precision (SP)	Ultra Precision (UP)
Dimensional tolerance of height H	± 0.1	± 0.03	0 -0.03	0 -0.015	0 -0.008
Dimensional tolerance of width N	± 0.1	± 0.03	0 -0.03	0 -0.015	0 -0.008
Variation of height H	0.02	0.01	0.006	0.004	0.003
Variation of width N	0.02	0.01	0.006	0.004	0.003
Running parallelism of block surface C to surface A	See Table 2-3-9				
Running parallelism of block surface D to surface B	See Table 2-3-9				

Table 2-3-4 Accuracy Standards

Unit: mm

Item	QH - 25, 30, 35				
	Normal (C)	High (H)	Precision (P)	Super Precision (SP)	Ultra Precision (UP)
Dimensional tolerance of height H	± 0.1	± 0.04	0 -0.04	0 -0.02	0 -0.01
Dimensional tolerance of width N	± 0.1	± 0.04	0 -0.04	0 -0.02	0 -0.01
Variation of height H	0.02	0.015	0.007	0.005	0.003
Variation of width N	0.03	0.015	0.007	0.005	0.003
Running parallelism of block surface C to surface A	See Table 2-3-9				
Running parallelism of block surface D to surface B	See Table 2-3-9				

Table 2-3-5 Accuracy Standards

Unit: mm

Item	QH - 45				
	Normal (C)	High (H)	Precision (P)	Super Precision (SP)	Ultra Precision (UP)
Dimensional tolerance of height H	± 0.1	± 0.05	0 -0.05	0 -0.03	0 -0.02
Dimensional tolerance of width N	± 0.1	± 0.05	0 -0.05	0 -0.03	0 -0.02
Variation of height H	0.03	0.015	0.007	0.005	0.003
Variation of width N	0.03	0.02	0.01	0.007	0.005
Running parallelism of block surface C to surface A	See Table 2-3-9				
Running parallelism of block surface D to surface B	See Table 2-3-9				



(2) Accuracy of interchangeable

Table 2-3-6 Accuracy Standards

Unit: mm

Item	QH - 15, 20		
	Normal (C)	High (H)	Precision (P)
Dimensional tolerance of height H	± 0.1	± 0.03	± 0.015
Dimensional tolerance of width N	± 0.1	± 0.03	± 0.015
Variation of height H	0.02	0.01	0.006
Variation of width N	0.02	0.01	0.006
Running parallelism of block surface C to surface A	See Table 2-3-9		
Running parallelism of block surface D to surface B	See Table 2-3-9		

Table 2-3-7 Accuracy Standards

Unit: mm

Item	QH - 25, 30, 35		
	Normal (C)	High (H)	Precision (P)
Dimensional tolerance of height H	± 0.1	± 0.04	± 0.02
Dimensional tolerance of width N	± 0.1	± 0.04	± 0.02
Variation of height H	0.02	0.015	0.007
Variation of width N	0.03	0.015	0.007
Running parallelism of block surface C to surface A	See Table 2-3-9		
Running parallelism of block surface D to surface B	See Table 2-3-9		

Table 2-3-8 Accuracy Standards

Unit: mm

Item	QH - 45		
	Normal (C)	High (H)	Precision (P)
Dimensional tolerance of height H	± 0.1	± 0.05	± 0.025
Dimensional tolerance of width N	± 0.1	± 0.05	± 0.025
Variation of height H	0.03	0.015	0.007
Variation of width N	0.03	0.02	0.01
Running parallelism of block surface C to surface A	See Table 2-3-9		
Running parallelism of block surface D to surface B	See Table 2-3-9		



(3) Accuracy of running parallelism

Table 2-3-9 Accuracy of Running Parallelism

Rail Length (mm)	Accuracy (μm)				
	C	H	P	SP	UP
~ 100	12	7	3	2	2
100 ~ 200	14	9	4	2	2
200 ~ 300	15	10	5	3	2
300 ~ 500	17	12	6	3	2
500 ~ 700	20	13	7	4	2
700 ~ 900	22	15	8	5	3
900 ~ 1,100	24	16	9	6	3
1,100 ~ 1,500	26	18	11	7	4
1,500 ~ 1,900	28	20	13	8	4
1,900 ~ 2,500	31	22	15	10	5
2,500 ~ 3,100	33	25	18	11	6
3,100 ~ 3,600	36	27	20	14	7
3,600 ~ 4,000	37	28	21	15	7

2-3-6 Preload

(1) Definition

A preload can be applied to each guideway. Oversized balls are used. Generally, a linear motion guideway has a negative clearance between groove and balls in order to improve stiffness and maintain high precision. The figure shows the load is multiplied by the preload, the rigidity is doubled and the deflection is reduced by one half. The preload no larger than ZA would be recommended for the model size under QH20 to avoid an over-preload affecting the guideway's life.

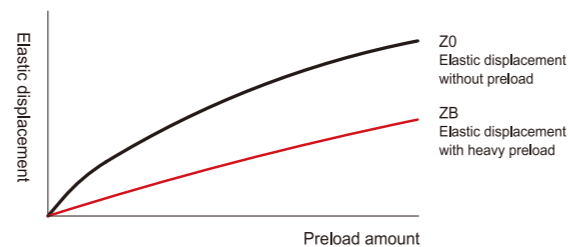

(2) Preload classes

LIMON offers three classes of standard preload for various applications and conditions.

Table 2-3-10 Preload Classes

Class	Code	Preload	Condition	Examples of Application
Light Preload	Z0	0~ 0.02C	Certain load direction, low impact, low precision required	Transportation devices, auto-packing machines, X-Y axis for general industrial machines, welding machines, welders
Medium Preload	ZA	0.05C~0.07C	High precision required	Machining centers, Z axis for general industrial machines, EDM, NC lathes, Precision X-Y tables, measuring equipment
Heavy Preload	ZB	0.10C~ 0.12C	High rigidity required, with vibration and impact	Machining centers, grinding machines, NC lathes, horizontal and vertical milling machines, Z axis of machine tools, Heavy cutting machines
Class	Interchangeable Guideway		Non-Interchangeable Guideway	
Preload classes	Z0, ZA		Z0, ZA, ZB	

Note: The "C" in the preload column denotes basic dynamic load rating.



2-3-7 Dust Proof Accessories

(1) Codes of accessories

If the following accessories are needed, please add the code followed by the model number.

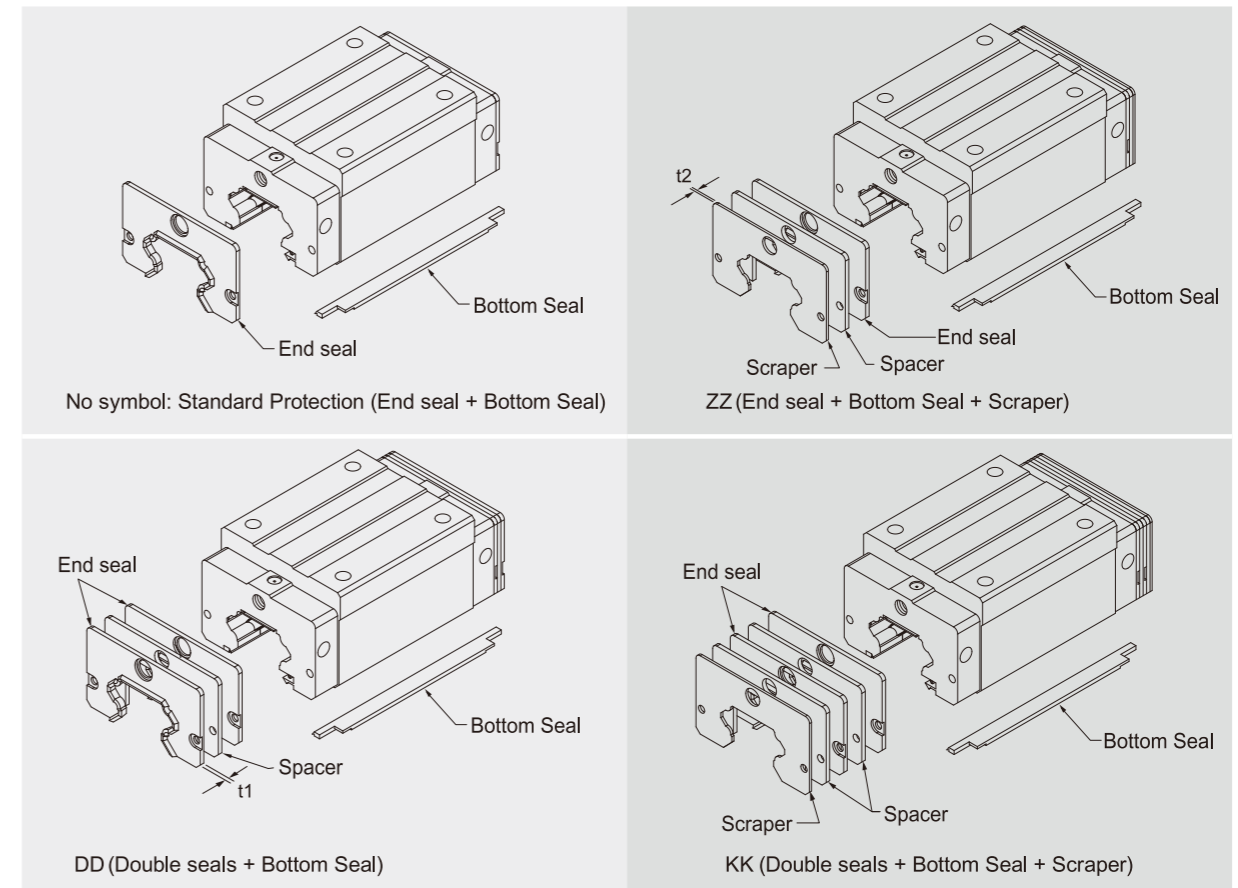

(2) End seal and bottom seal

To prevent life reduction caused by iron chips or dust entering the block.

(3) Double seals

Enhances the wiping effect, foreign matter can be completely wiped off.

Table 2-3-11 Dimensions of end seal

Size	Thickness (t1) (mm)	Size	Thickness (t1) (mm)
QH15 ES	3	QH30 ES	3.2
QH20 ES	2.5	QH35 ES	2.5
QH25 ES	2.5	QH45 ES	3.6

(4) Scraper

The scraper removes high-temperature iron chips and larger foreign objects.

Table 2-3-12 Dimensions of scraper

Size	Thickness (t2) (mm)	Size	Thickness (t2) (mm)
QH15 SC	1.5	QH30 SC	1.5
QH20 SC	1.5	QH35 SC	1.5
QH25 SC	1.5	QH45 SC	1.5



(5) Dimensions of block equipped with the dustproof parts

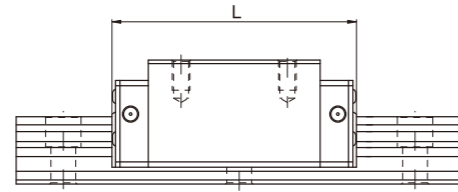

Table 2-3-13 Overall block length

unit: mm

Size	Overall block length (L)			
	SS	ZZ	DD	KK
QH15C	60.5	64.1	65.5	69.1
QH20C	76.7	80.3	82.5	86.1
QH20H	91.4	95	97.2	100.8
QH25C	84	87.6	90	93.6
QH25H	104.6	108.2	110.6	114.2
QH30C	98.4	102	104.6	108.2
QH30H	121.4	125	127.6	131.2
QH35C	112.4	116	118.8	122.4
QH35H	138.2	141.8	144.6	148.2
QH45C	137.4	141	145.4	149
QH45H	169.2	172.8	177.2	180.8

Note : The marking of "()" denotes the maximum block length with screws, lips of end seals, etc.

2-3-8 Dimensions for QH Series

(1) QHH-CA / QHH-HA

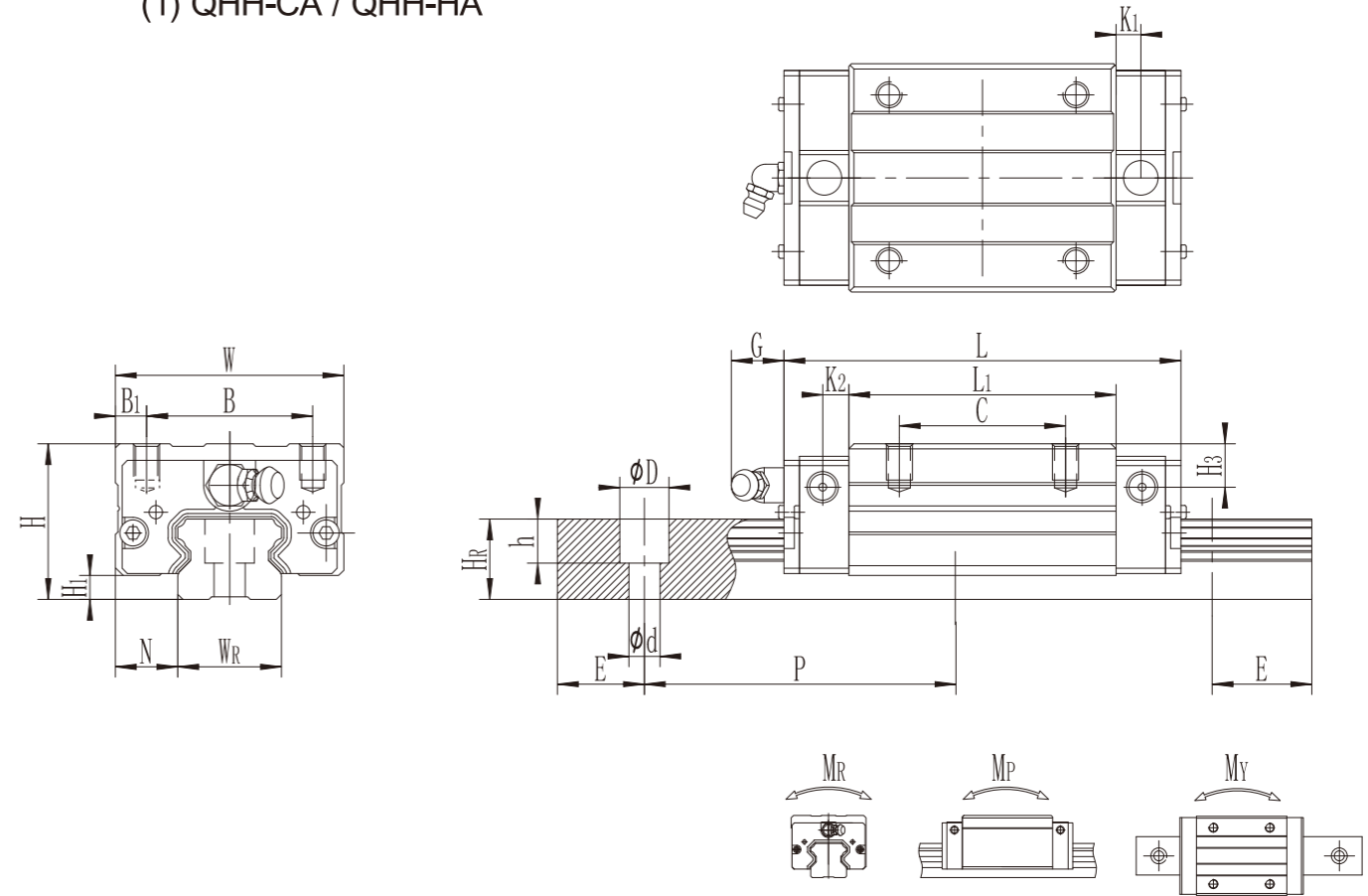

Model No.	Dimensions of Assembly (mm)		Dimensions of Block(mm)																Dimensions of Rail (mm)		Mounting Bolt for Rail (mm)	Basic Dynamic Load Rating C(KN)	Basic Static Load Rating C0(KN)	Static Rated Moment			Weight					
	H	H1	N	W	B	B1	C	L1	L	K1	K2	G	M*L	T	H2	H3	WR	HR	D	h				d	P	E	MR KN-m	MP KN-m	MY KN-m	Block kg	Rail kg/m	
★ QHH15CA	28	3.2	9.5	34	26	4	26	39.8	62.2	3.5	3.5	5.5	M4X7	6	9.5	9	15	12.5	6	4.5	3.5	60	20	M3×16	11.96	14.46	0.08	0.06	0.06	0.21	1.26	
QHH15CA	28	3.2	9.5	34	26	4	26	39.8	62.2	3.5	3.5	5.5	M4X7	6	9.5	9	15	12.5	7.5	5.3	4.5	60	20	M4×16	11.96	14.46	0.08	0.06	0.06	0.21	1.26	
QHH20CA	30	4.6	12	44	32	6		36	51.5	76.5																						
QHH20HA								50	69.5	94.5	4.75	5	12	M5X7	8	8	8.5	20	15.5	9.5	8.5	6	60	20	M5×16	21.14	28.33	0.28	0.25	0.25	0.4	2.09
QHH25CA	40	4.5	12.5	48	35	6.5		35	59.5	82.5																						
QHH25HA								50	81.5	104.5	4.75	5	12	M6X8	8	13	13	23	18	11	9	7	60	20	M6×20	32.88	42.17	0.48	0.42	0.42	0.72	2.69
★ QHH30CA	45	7	16	60	40	10		40	70	98																						
QHH30HA								60	93.5	121.5	6	5	12	M8X10	8.5	11	11	28	23	11	9	7	80	20	M6×25	52.09	62.13	0.8	0.85	0.85	1.18	4.26
QHH30CA	45	7	16	60	40	10		40	70	98																						
QHH30HA								60	93.5	121.5	6	5	12	M8X10	8.5	11	11	28	23	14	12	9	80	20	M8×25	52.09	62.13	0.8	0.85	0.85	1.18	4.26

Note : 1 kgf = 9.81 N

Model with "*" means guide rail with new installation hole, pls not the requirement when placing the order.

Linear Guideways - QH Series



(2) QHW-CA / QHW-HA

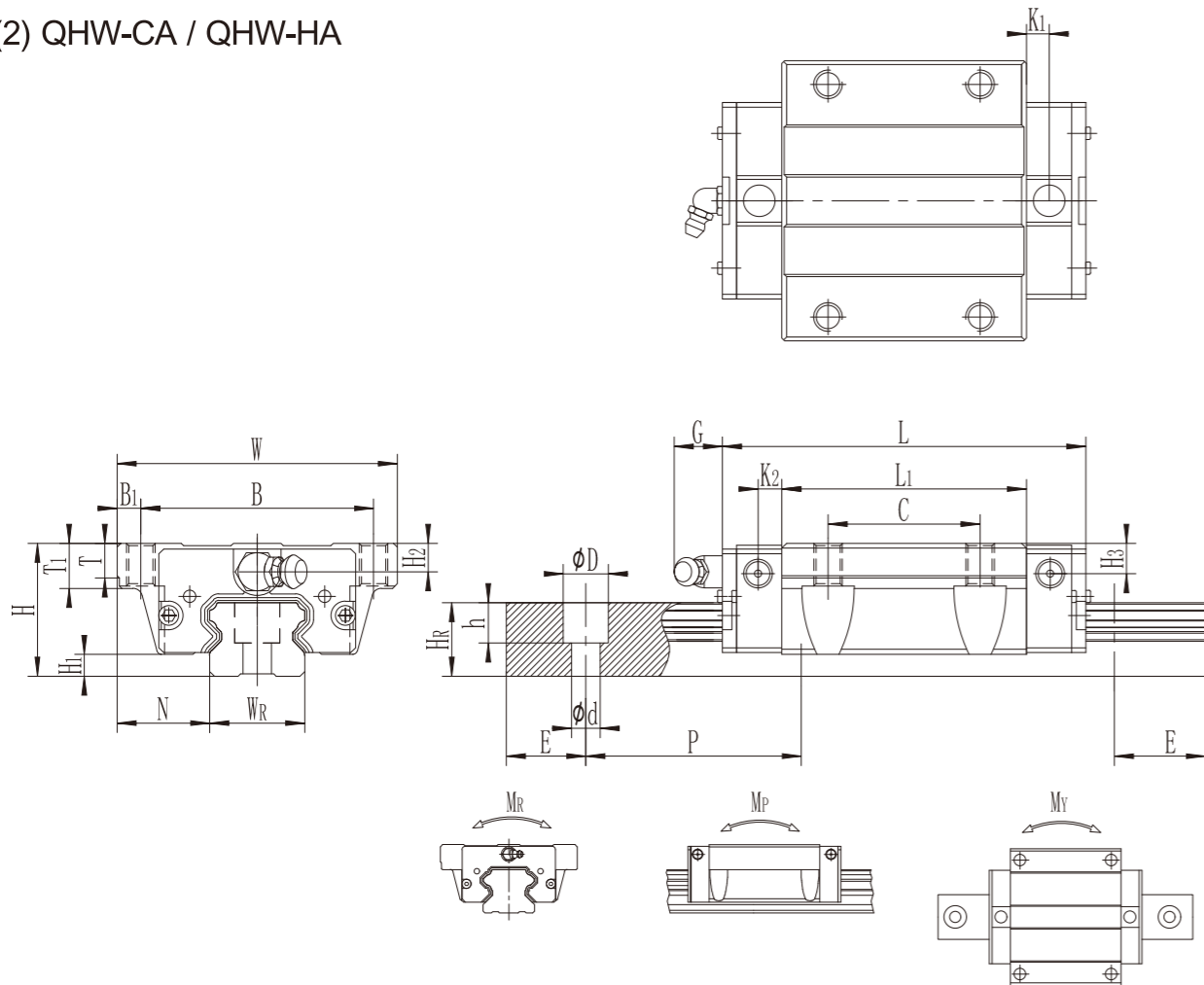

Model No.	Dimensions of Assembly (mm)		Dimensions of Block(mm)														Mounting Bolt for Rail (mm)	Basic Dynamic Load Rating C(KN)	Basic Static Load Rating C0(KN)	Static Rated Moment			Weight										
	H	H1	N	W	B	B1	C	L1	L	K1	K2	G	M	T	T1	H2				H3	WR	HR	D	h	d	P	E	MR	MP	MY	Block kg	Rail kg/m	
★ QHW15CA	24	4	16	47	38	4.5	30	39.8	62.2	3.35	4.75	5.5	M5	6	7	5.5	5	15	12.5	6	4.5	3.5	60	20	M3×16	11.96	14.46	0.08	0.06	0.06	0.21	1.26	
QHW15CA	24	4	16	47	38	4.5	30	39.8	62.2	3.35	4.75	5.5	M5	6	7	5.5	5	15	12.5	7.5	5.3	4.5	60	20	M4×16	11.96	14.46	0.08	0.06	0.06	0.21	1.26	
QHW20CA	30	4.6	21.5	63	53	5	40		51.5	76.5	4.75	5	12	M6	8	9	8	8.5	20	15.5	9.5	8.5	6	60	20	M5×16	17.46	21.59	0.22	0.15	0.15	0.32	2.09
QHW20HA									69.5	94.5																							
QHW25CA	36	4.5	23.5	70	57	6.5	45		59.5	82.5	4.75	5	12	M8	8	10	9	9	23	18	11	9	7	60	20	M6×20	25.65	29.52	0.35	0.25	0.25	0.55	2.69
QHW25HA									81.5	104.5																							
★ QHW30CA	42	7	31	90	72	9	52		70	98	6	5	12	M10	8	10	8	8	28	23	11	9	7	80	20	M6×25	42.17	45.22	0.52	0.45	0.45	0.9	4.26
QHW30HA									93.5	121.5																							
QHW30CA	42	7	31	90	72	9	52		70	98	6	5	12	M10	8	10	8	8	28	23	14	12	9	80	20	M8×25	42.17	45.22	0.52	0.45	0.45	0.9	4.26
QHW30HA									93.5	121.5																							

Note : 1 kgf = 9.81 N

Model with "*" means guide rail with new installation hole, pls not the requirement when placing the order.

Linear Guideways - QH Series



(3) QHW-CB / QHW-HB

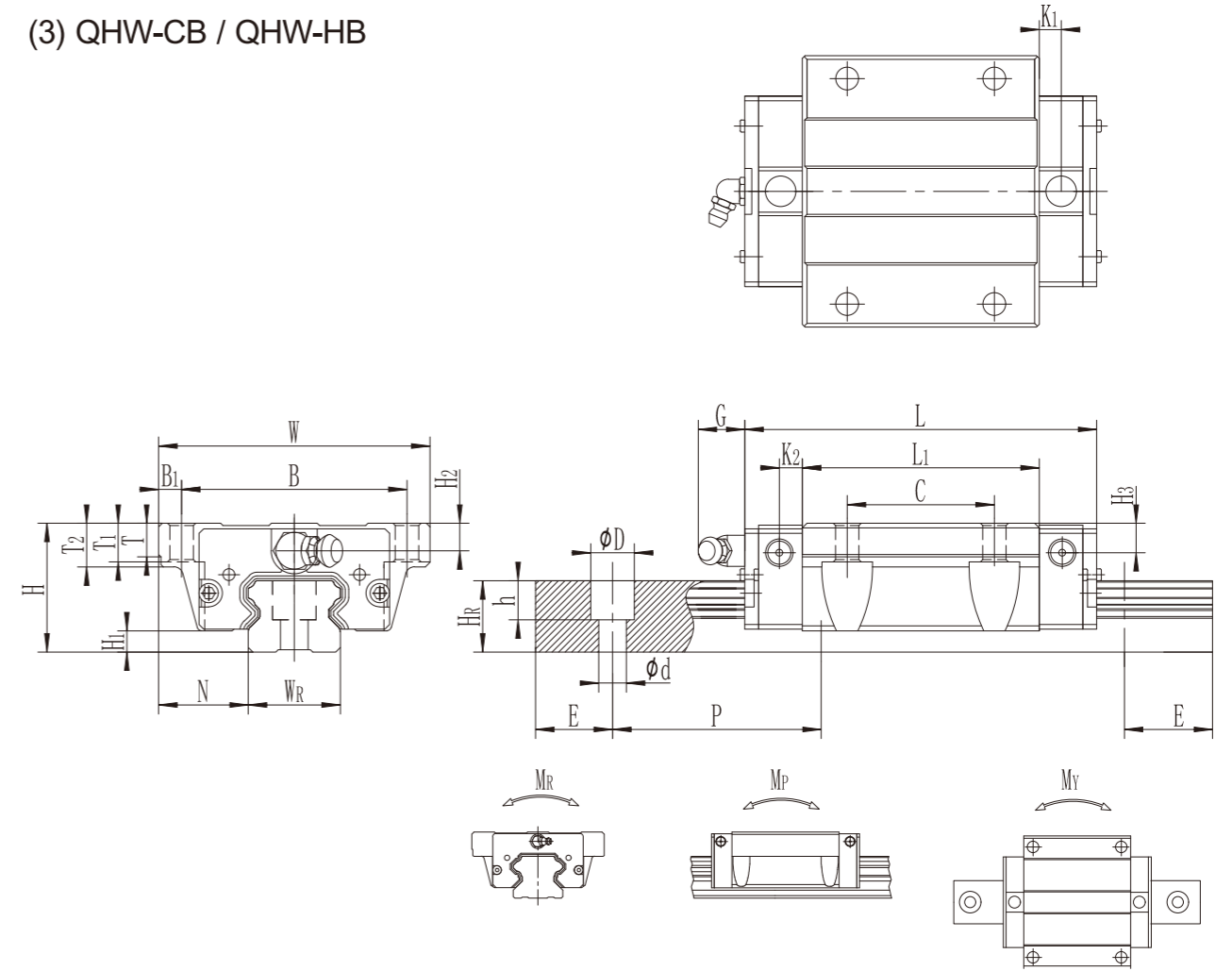

Model No.	Dimensions of Assembly (mm)		Dimensions of Block(mm)														Mounting Bolt for Rail (mm)	Basic Dynamic Load Rating C(KN)	Basic Static Load Rating C0(KN)	Static Rated Moment			Weight											
	H	H1	N	W	B	B1	C	L1	L	K1	K2	G	M	T	T1	T2				H2	H3	WR	HR	D	h	d	P	E	MR	MP	MY	Block kg	Rail kg/m	
★ QHW15CB	24	4	16	47	38	4.5	30	39.8	62.2	3.35	4.75	5.5	φ4.5	6	7	8.9	5.5	5	15	12.5	6	4.5	3.5	60	20	M3×16	11.96	14.46	0.08	0.06	0.06	0.21	1.26	
QHW15CB	24	4	16	47	38	4.5	30	39.8	62.2	3.35	4.75	5.5	φ4.5	6	7	8.9	5.5	5	15	12.5	7.5	5.3	4.5	60	20	M4×16	11.96	14.46	0.08	0.06	0.06	0.21	1.26	
QHW20CB	30	4.6	21.5	63	53	5	40		51.5	76.5	4.75	5	12	φ6	8	9	10	8	8.5	20	15.5	9.5	8.5	6	60	20	M5×16	17.46	21.59	0.22	0.15	0.15	0.32	2.09
QHW20HB									69.5	94.5																								
QHW25CB	36	4.5	23.5	70	57	6.5	45		59.5	82.5	4.75	5	12	φ7	8	10	14	9	9	23	18	11	9	7	60	20	M6×20	25.65	29.52	0.35	0.25	0.25	0.55	2.69
QHW25HB									81.5	104.5																								
★ QHW30CB	42	7	31	90	72	9	52		70	98	6	5	12	φ9	8.5	10	16	8	8	28	23	11	9	7	80	20	M6×25	42.17	45.22	0.52	0.45	0.45	0.9	4.26
QHW30HB									93.5	121.5																								
QHW30CB	42	7	31	90	72	9	52		70	98	6	5	12	φ9	8.5	10	16	8	8	28	23	14	12	9	80	20	M8×25	42.17	45.22	0.52	0.45	0.45	0.9	4.26
QHW30HB									93.5	121.5																								

Note : 1 kgf = 9.81 N

Model with "*" means guide rail with new installation hole, pls not the requirement when placing the order.



(4) QHW-CC / QHW-HC

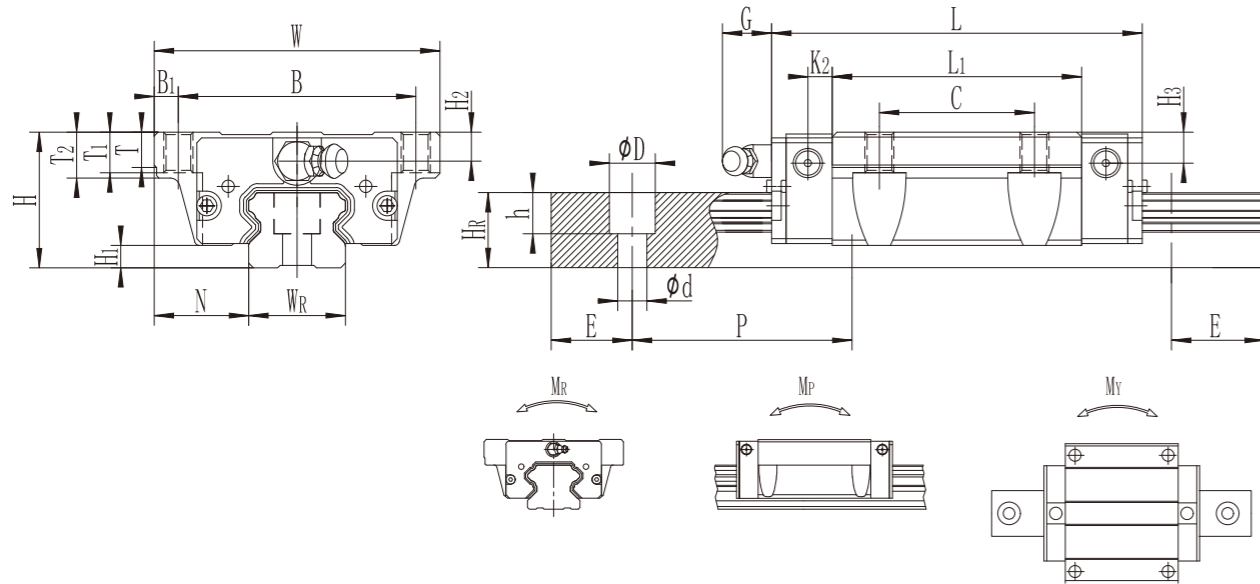
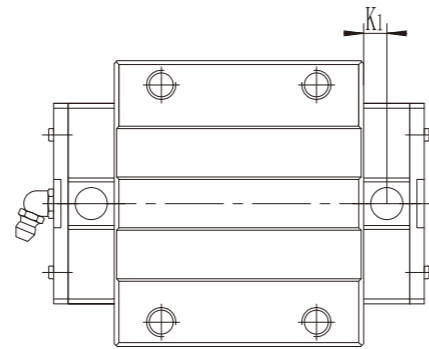

Model No.	Dimensions of Assembly (mm)			Dimensions of Block(mm)														Dimensions of Rail (mm)				Mounting Bolt for Rail (mm)	Basic Dynamic Load Rating C(KN)	Basic Static Load Rating C0(KN)	Static Rated Moment			Weight					
	H	H ₁	N	W	B	B ₁	C	L ₁	L	K ₁	K ₂	G	M	T	T ₁	T ₂	H ₂	H ₃	W _R	H _R	D				h	d	P	E	M _R KN-m	M _P KN-m	M _Y KN-m	Block kg	Rail kg/m
★ QHW15CC	24	4	16	47	38	4.5	30	39.8	62.2	3.35	4.75	5.5	M5	6	6.95	8.9	5.5	5	15	12.5	6	4.5	3.5	60	20	M3×16	11.96	14.46	0.08	0.06	0.06	0.21	1.26
QHW15CC	24	4	16	47	38	4.5	30	39.8	62.2	3.35	4.75	5.5	M5	6	6.95	8.9	5.5	5	15	12.5	7.5	5.3	4.5	60	20	M4×16	11.96	14.46	0.08	0.06	0.06	0.21	1.26
QHW20CC	30	4.6	21.5	63	53	5	40	51.5	76.5	4.75	5	12	M6	8	9	10	8	8.5	20	15.5	9.5	8.5	6	60	20	M5×16	17.46	21.59	0.22	0.15	0.15	0.32	2.09
QHW20HC	30	4.6	21.5	63	53	5	40	69.5	94.5	4.75	5	12	M6	8	9	10	8	8.5	20	15.5	9.5	8.5	6	60	20	M5×16	21.14	28.33	0.28	0.25	0.25	0.4	2.09
QHW25CC	36	4.5	23.5	70	57	6.5	45	59.5	82.5	4.75	5	12	M8	8	10	14	9	9	23	18	11	9	7	60	20	M6×20	25.65	29.52	0.35	0.25	0.25	0.55	2.69
QHW25HC	36	4.5	23.5	70	57	6.5	45	81.5	104.5	4.75	5	12	M8	8	10	14	9	9	23	18	11	9	7	60	20	M6×20	32.88	42.17	0.48	0.42	0.42	0.72	2.69
★ QHW30CC	42	7	31	90	72	9	52	70	98	6	5	12	M10	8.5	10	16	8	8	28	23	11	9	7	80	20	M6×25	42.17	45.22	0.52	0.45	0.45	0.9	4.26
QHW30HC	42	7	31	90	72	9	52	93.5	121.5	6	5	12	M10	8.5	10	16	8	8	28	23	11	9	7	80	20	M6×25	52.09	62.13	0.8	0.85	0.85	1.18	4.26
★ QHW30CC	42	7	31	90	72	9	52	70	98	6	5	12	M10	8.5	10	16	8	8	28	23	14	12	9	80	20	M8×25	42.17	45.22	0.52	0.45	0.45	0.9	4.26
QHW30HC	42	7	31	90	72	9	52	93.5	121.5	6	5	12	M10	8.5	10	16	8	8	28	23	14	12	9	80	20	M8×25	52.09	62.13	0.8	0.85	0.85	1.18	4.26

Note : 1 kgf = 9.81 N

Model with "*" means guide rail with new installation hole, pls not the requirement when placing the order.



2-4 QE Series – Low Profile Linear Guideway, with SynchMotion™ Technology

The development of LIMON-QE linear guideway is based on a four-row circular-arc contact. The LIMON-QE series linear guideway with SynchMotion™ Technology offers smooth movement, superior lubrication, quieter operation and longer running life. Therefore the LIMON-QE linear guideway has broad industrial applicability. In the high-tech industry where high speed, low noise, and reduced dust generation is required, the LIMON-QE series is interchangeable with the LIMON-E series.

2-4-1 Construction of QE Series

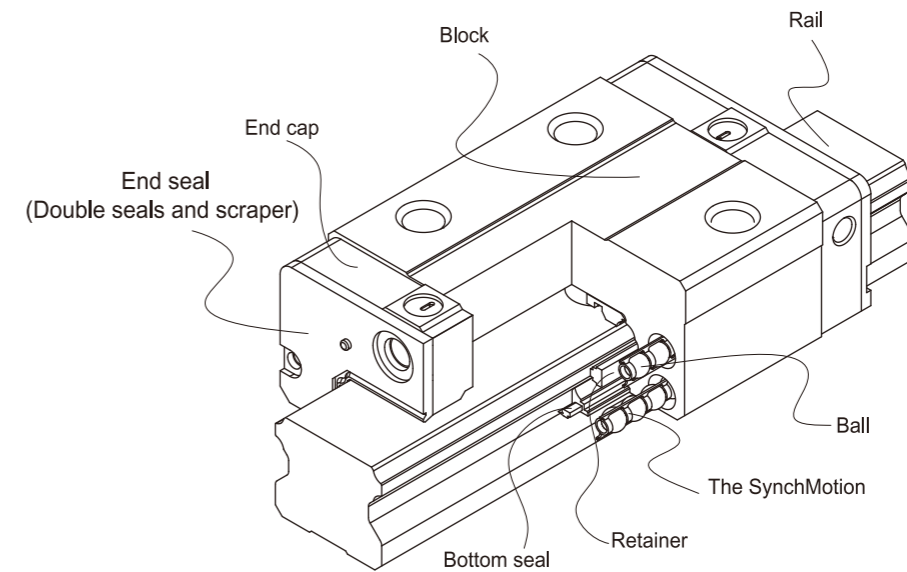

2-4-2 Model Number of QE Series

LIMON-QE series guideway can be classified into non-interchangeable and interchangeable types. The sizes are identical. The main difference is that the interchangeable blocks and rails can be freely exchanged. Because of dimensional control, the interchangeable type linear guideway is a perfect choice for the client when rails do not need to be paired for an axis. And since the QE and E share the identical rails, the customer does not need to redesign when choosing the QE series. Therefore the LIMON-QE linear guideway has increased applicability.