

Gas/Light Oil - Gas/Gasolio

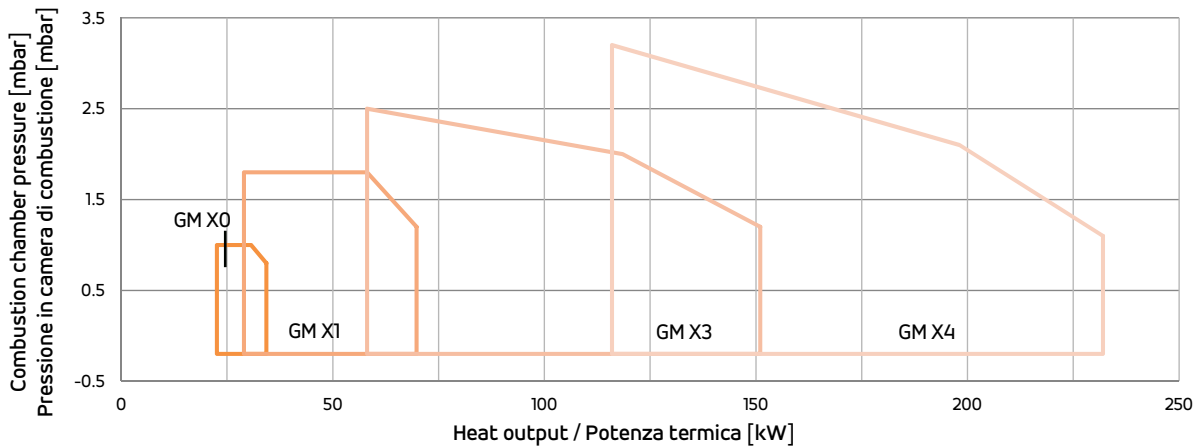

1 STAGE MONOSTADIO	kcal/h		kW		
	min	max	min	max	
GM X 0	19.500	29.500	22,6	34,3	1F
GM X 1	25.000	60.000	29	69,8	
GM X 3	50.000	130.000	58,1	151	
GM X 4	100.000	200.000	116	232	

FIRING RATES / OVERALL DIMENSIONS (mm) - CAMPO DI LAVORO / DIMENSIONI (mm)

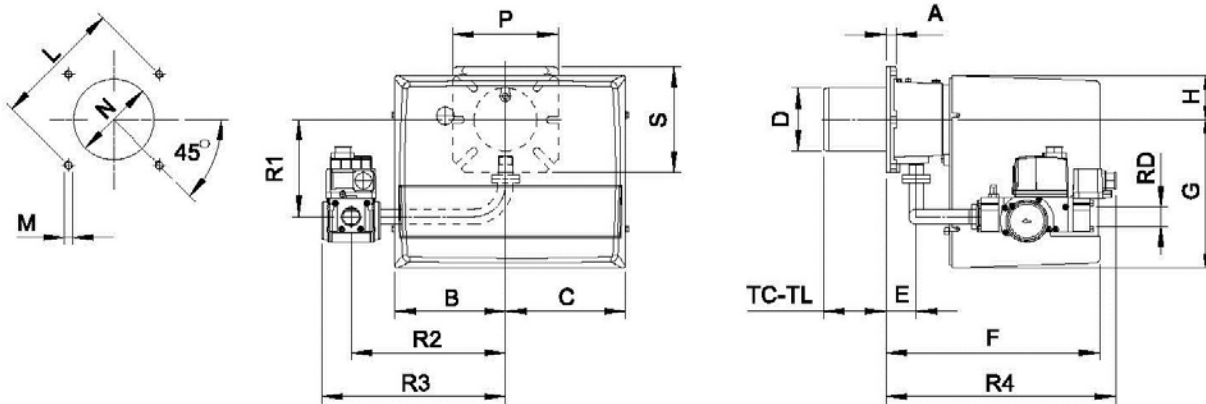

MODEL MODELLO																					* Suggested/					Consigliato/
	A	B	C	D	E	F	G	H	L min	L*	L max	M	N min	N*	N max	P	S	TC	TL	R1	R2	R3	R4	RD		
GM X 0 - D1/2" - S	15	162	175	90	43	305	210	65	130	150	170	M8	100	110	130	150	150	90	150	132	200	254	240	1/2"		
GM X 1 - D1/2" - S	15	162	175	90	43	305	210	65	130	150	170	M8	100	110	130	150	150	90	150	132	200	254	240	1/2"		
GM X 1 - D3/4" - S	15	162	175	90	43	305	210	65	130	150	170	M8	100	110	130	150	150	90	150	138	220	262	328	3/4"		
GM X 3 - D1" - S	16	185	195	108	54	340	248	70	150	170	170	M8	120	130	140	190	150	130	250	168	280	337	361	1"		
GM X 4 - D1" - S	20	185	195	125	78	368	248	70	170	205	226	M10	130	140	160	200	200	160	280	173	280	337	385	1"		