

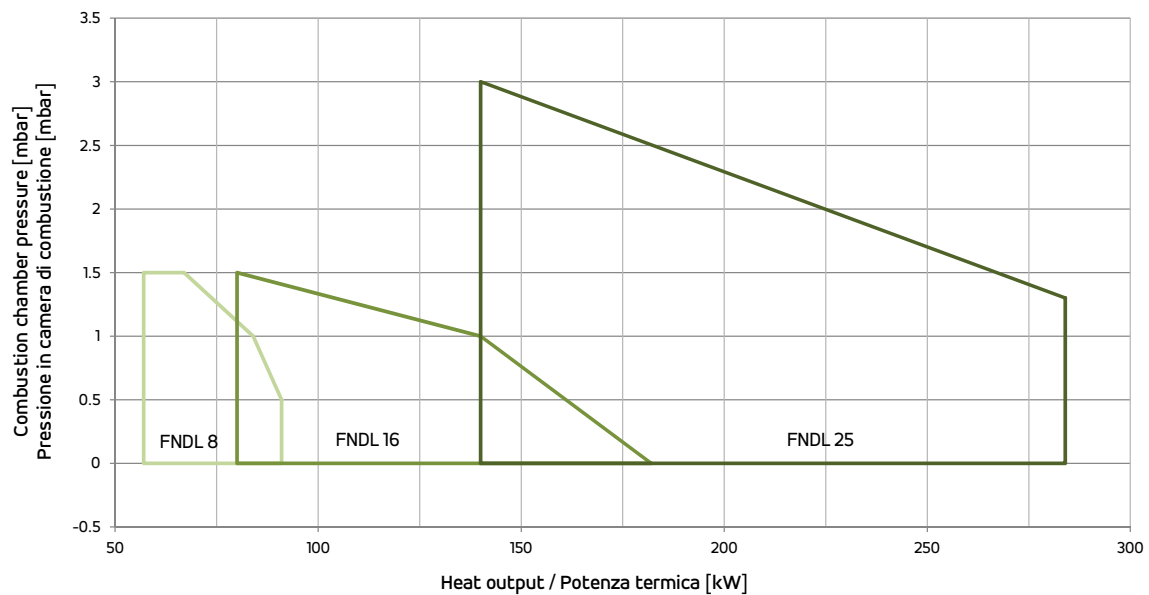

1 STAGE MONOSTADIO	kg/h		kW		⚡
	min	max	min	max	
FNDL 8	5	8	57	91,1	1F
FNDL 16	7	16	79,8	182	
FNDL 25	12,5	25	142	285	3F

FIRING RATES / OVERALL DIMENSIONS (mm) - CAMPO DI LAVORO / DIMENSIONI (mm)

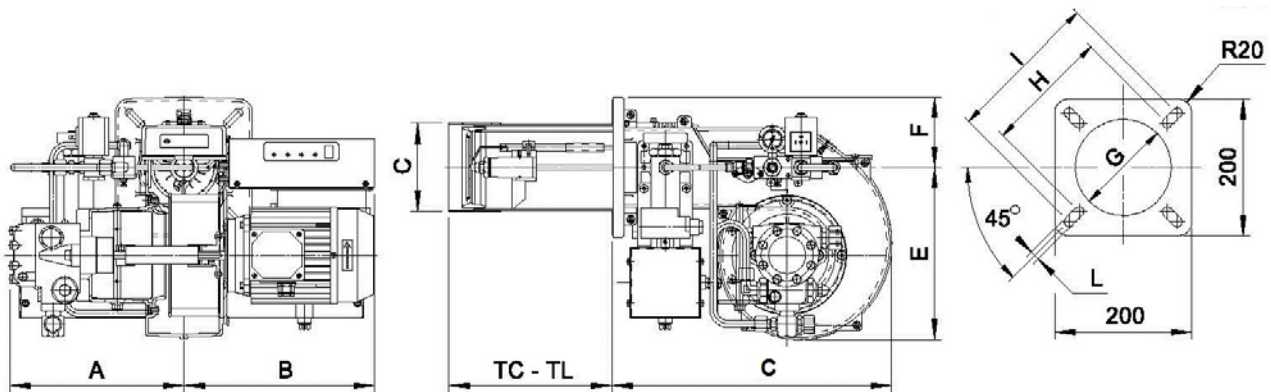

MODEL MODELLO	A	B	C	D	E	F	G	H	I	L	TC	TL
FNDL 8	253	294	410	107	251	102	120	180	226	M10	110	230
FNDL 16	253	294	410	107	251	102	120	180	226	M10	110	230
FNDL 25	255	294	410	130	251	102	140	180	226	M10	120	240