

3 STAGES TRISTADIO	kg/h		kW		⚡
	min	max	min	max	
FGP 190/3	22/60	206	255/712	2443	3F
FGP 250/3	27/80	250	313/949	2965	
FGP 350/3 EL	49/140	350	568/1660	4151	
FGP 450/3 EL	55/160	450	638/1898	5337	

FIRING RATES / OVERALL DIMENSIONS (mm) - CAMPO DI LAVORO / DIMENSIONI (mm)

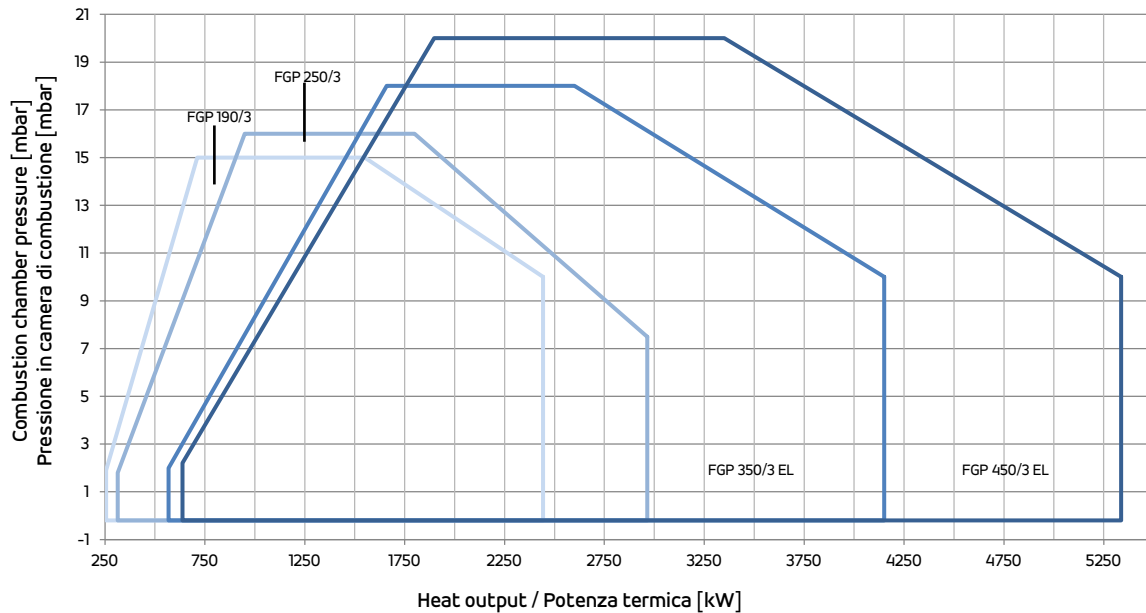
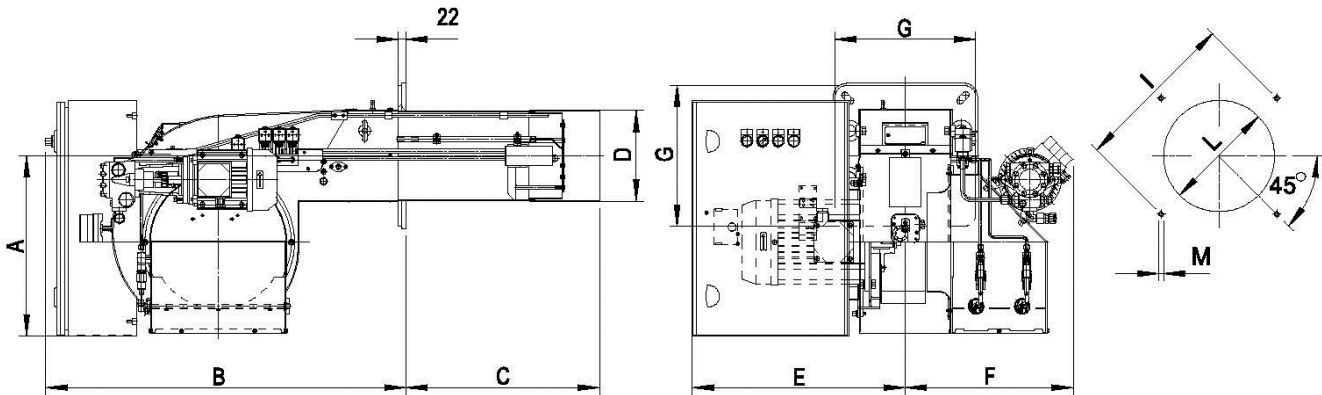

MODEL MODELLO	* Suggested/Consigliato													
	A	B	C	D	E	F	G	I min	I *	I max	L min	L *	L max	M
FGP 190/3	460	920	495	234	545	429	360	396	424	438	245	280	320	M14
FGP 250/3	460	920	500	271	545	460	360	396	424	438	280	280	320	M14
FGP 350/3	481	1090	535	334	700	517	490	552	552	580	350	350	450	M14
FGP 450/3	481	1090	560	380	700	517	490	552	552	580	390	390	450	M14