

3 STAGES TRISTADIO	kg/h		kW		
	min	max	min	max	
FNDP 190/3	40/80	206	456/911	2347	3F
FNDP 250/3	50/100	250	570/1139	2849	
FNDP 350/3 EL	60/120	350	684/1367	3988	
FNDP 450/3 EL	80/160	450	911/1823	5128	

FIRING RATES / OVERALL DIMENSIONS (mm) - CAMPO DI LAVORO / DIMENSIONI (mm)

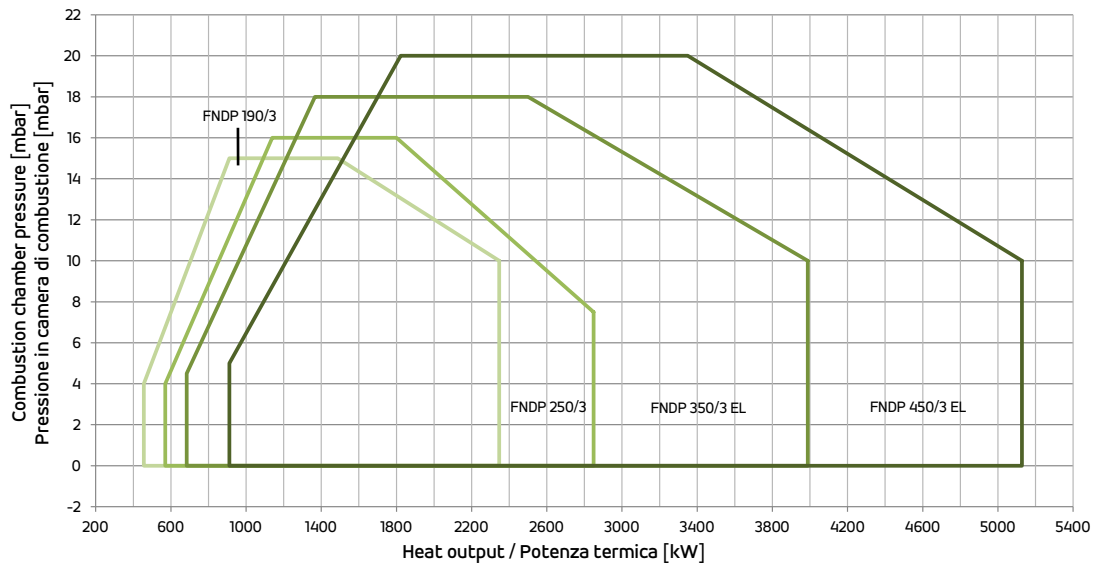
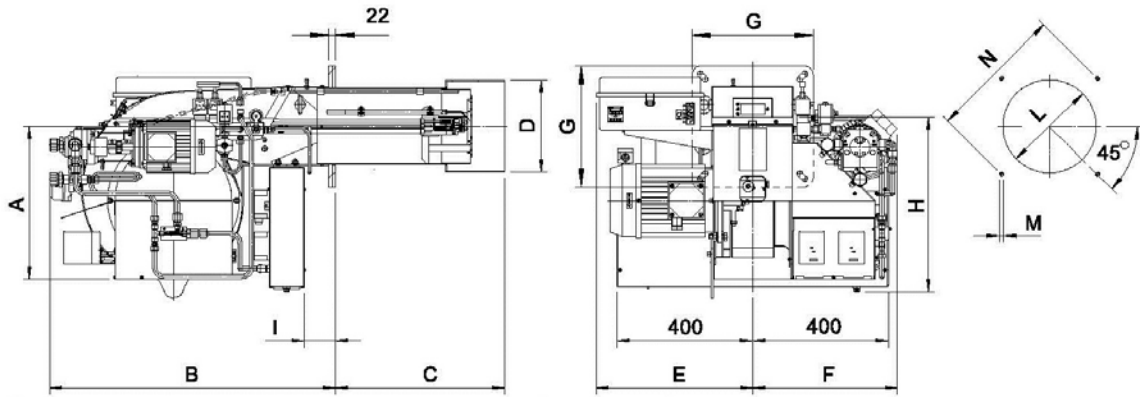

MODEL MODELLO	* Suggested/Consigliato																
	A	B	C	D	E	F	G	H	I	L min	L*	L max	M	N min	N*	N max	R
FNDP 190/3	453	850	495	234	464	430	360	490	93	245	280	320	M14	396	424	438	R30
FNDP 250/3	453	850	500	271	464	430	360	490	93	280	280	320	M14	396	424	438	R30
FNDP 350/3 EL	495	1085	535	334	700	488	490	495	55	350	350	450	M14	552	552	580	R50