

TERA-G2 EV Series

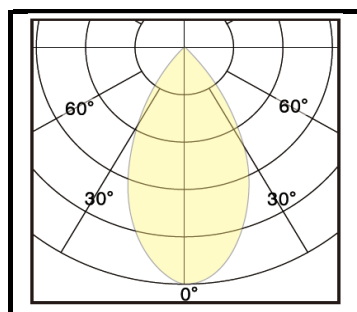
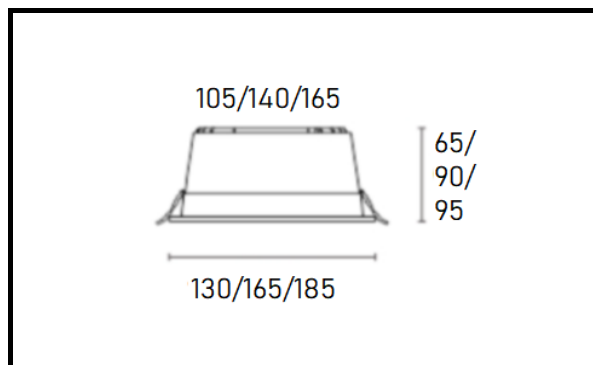

TERA-G2 EV Series
LED CCT AVAILABLE
3000K
4000K
6500K

Optional Color (CCT)
2700K
3500K

Dimension
12W- 130*65mm (C 105mm)
20W- 165*90mm (C 140mm)
30W- 185*95mm (C 165mm)

Product Description
Aluminium Die Casting;
Double powder Coating;
Recessed Luminaire;
2 cable entries. Through wiring possible. (N/L)
LED module: High Efficiency SMD LED
Protection mode IP20
Weigth: 1.1kg
Beam Angle: 100deg

Technical data

Model Code	TERA G2 EV6-W12-D100
Luminous flux	1080lm / 1800lm / 2700lm
Power Consumption	12W/20W/30W
Lumen Output	>90lm/W
Lifetime	30K Hours
Power Factor	> 0.9
Color Rendering	> 80
SDCM	< 3
UGR	< 19
Lamp Type	Recessed Luminaire;
Beam Angle	100deg
Housing Material	Aluminium
Housing Color	White / Black / Aluminium
Dimension	Refer to Dimension Details
Dimmable	Available ON / OFF
	Optional: 0-10V/ DALI / TRIAC

WETRONIC.