



Lab Master LGS510 Series

5.0 Purity Single Stage Nickel Plated Brass Barstock Diaphragm
Cylinder Regulator – Acetylene



The Lab Master LGS510 Series single stage diaphragm cylinder regulators are designed for primary pressure gas control of high purity Acetylene gas up to grade 5.0 purity (99.999%), on applications where slight pressure variation from decreasing cylinder pressure is acceptable.

- LGS510 Series | Single Stage Diaphragm Cylinder Regulator, EPDM Pressure Relief Valve

★ FEATURES

- Six port configuration
- Rear panel mounting capabilities
- Encapsulated seat design
- Low wetted surface area
- Full range of inlet and outlet fittings
- Side entry

📦 MATERIAL

▪ Body	Nickel Plated Brass Barstock
▪ Bonnet	High Strength Alloy
▪ Diaphragm	316L Stainless Steel
▪ Bonnet Seal	PTFE
▪ Seat	Polyamide (Nylon®)
▪ Filter	10 Micron 316L Stainless Steel

👍 SPECIFICATION

▪ Maximum Inlet Pressure	25 bar (360 PSI)
▪ Delivery Pressure Range	0 to 1 bar (15 PSI) 0 to 1.5 bar (22 PSI)
▪ Gauges	50mm (2") Diameter
▪ Ports	1/4" NPT Female
▪ Temperature Range	-20° C to +60° C (-4° F to +140° F)
▪ Weight	1.2 kg (2.7 lb) **

** Cylinder connection not included

✓ FLOW PERFORMANCE

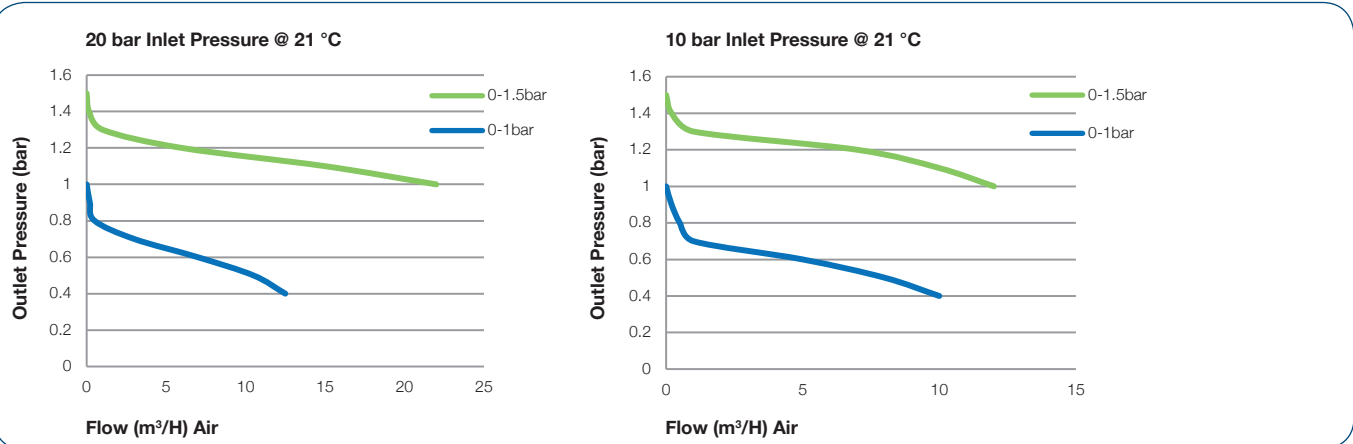

DRAWINGS

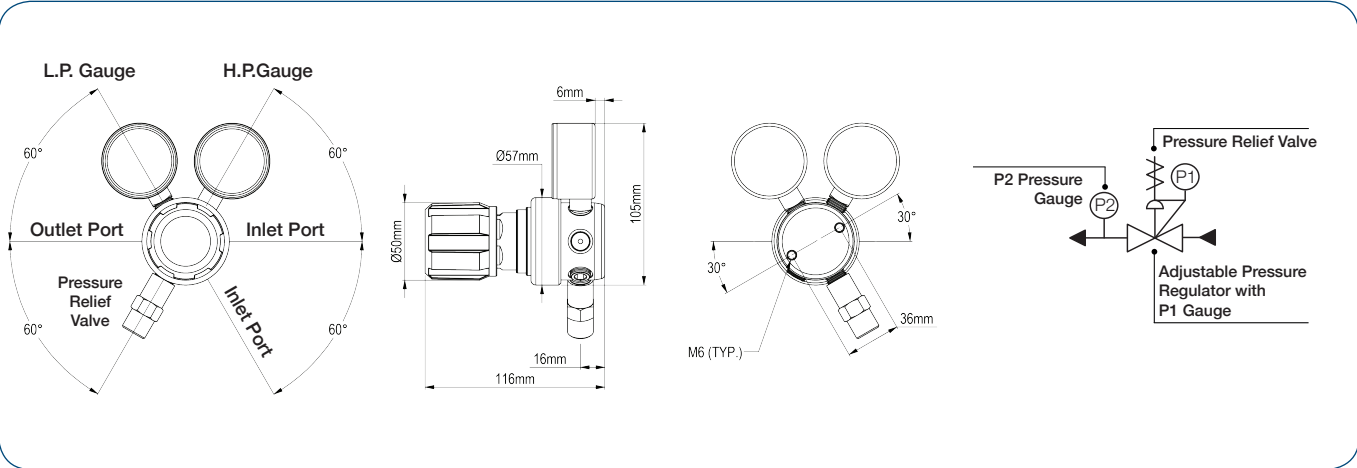

MODEL NO. SELECTOR GUIDE

Example for a Model No. for LGS510 Series

Product Type	Inlet Pressure Bar [PSI]	Outlet Pressure Bar [PSI]	Inlet Pressure Gauge	Outlet Pressure Gauge	Inlet/Cylinder Connection	Outlet Connection	Options
LGS510-	01 25 [360]	01 0 to 1.0 [15]	00 No Gauge Fitted	00 No Gauge Fitted	000 1/4" NPT Female	00 1/4" NPT Female	A No Options Selected
		02 0 to 1.5 [22]	01 bar/PSI	01 bar/PSI	001 1/8 Stainless Steel Compression	01 1/8 Stainless Steel Compression	B Regulator Tee Purge FKM
			10 Plugged Port	10 Plugged Port	002 1/4 Stainless Steel Compression	02 1/4 Stainless Steel Compression	C Regulator Tee Purge EPDM
					003 6mm Stainless Steel Compression	03 6mm Stainless Steel Compression	K Certificate of Conformity (CoC)
					004 1/4 NPT Male	04 1/4 NPT Male	P Calibration / Pressure Test Certificate
					008 G3/8 BSP L/H Brass Male	08 G3/8 BSP L/H, Brass, Male	X Special Instruction
					012 BS341 No.4	10 Isolation Valve, 1/4 NPT Female, EPDM Seal	
					027 DIN477 No.3	12 Isolation Valve, 1/8 Stainless Steel Compression, EPDM Seal	
					028 DIN477 No.3.1	14 Isolation Valve, 1/4 Stainless Steel Compression, EPDM Seal	
					050 CGA510	16 Isolation Valve, 6mm Stainless Steel Compression, EPDM Seal	
					For our complete range of cylinder connections refer to 'Cylinder Connections Data'		