

## Chem Master SGL600 Series

6.0 Purity Single Stage Stainless Steel Diaphragm Line Regulator



The Chem Master SGL600 single stage diaphragm line regulators are designed for secondary pressure gas control of corrosive, toxic and high purity gases up to grade 6.0 purity (99.9999%), on gas distribution systems.

■ **SGL600 Series** | Single Stage Diaphragm Line Regulator

### ★ FEATURES

- Four port configuration
- Front and rear panel mounting capabilities
- Encapsulated seat design
- Low wetted surface area
- Full range of inlet and outlet fittings
- Side entry

### 🔧 MATERIAL

- **Body** 316L Stainless Steel
- **Bonnet** Nickel Plated Brass Barstock
- **Diaphragm** 316L Stainless Steel
- **Seal** PTFE
- **Seat** PCTFE
- **Filter** 10 Micron 316L Stainless Steel

\*\*\* NACE and 3.1 material certificates available on request, please contact the sales office for further information.

### 👍 SPECIFICATION

- **Maximum Inlet Pressure** 207 bar (3000 PSI)
- **Delivery Pressure Range** 1.5 bar (22 PSI)  
3.5 bar (50 PSI)  
6 bar (90 PSI)  
10 bar (150 PSI)
- **Gauges** 50mm (2") Diameter
- **Ports** 1/4" NPT Female
- **Temperature Range** -20° C to +60° C (-4° F to +140° F)
- **Flow Coefficient (Cv)** 0.1
- **Helium Leak Integrity**  $1 \times 10^{-9}$  mbar l/s
- **Weight** 1.1 kg (2.5 lb)

### ✓ FLOW PERFORMANCE

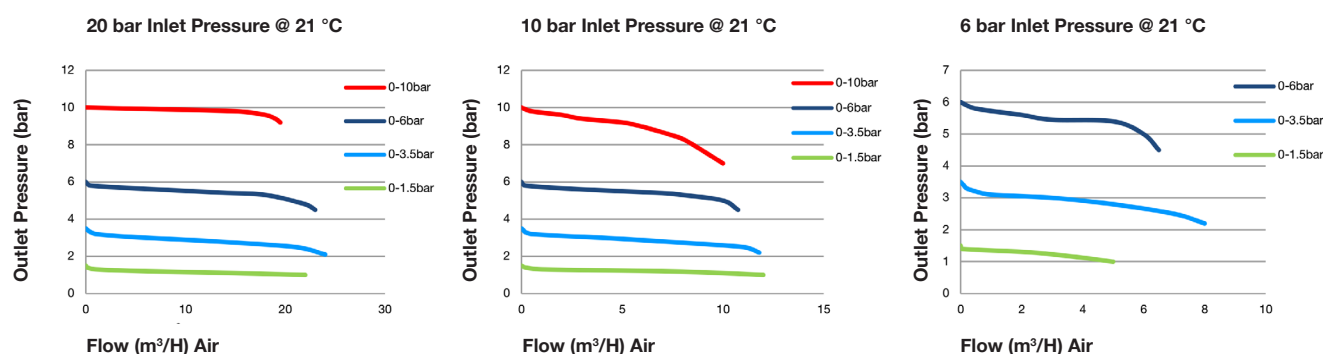

## DRAWINGS

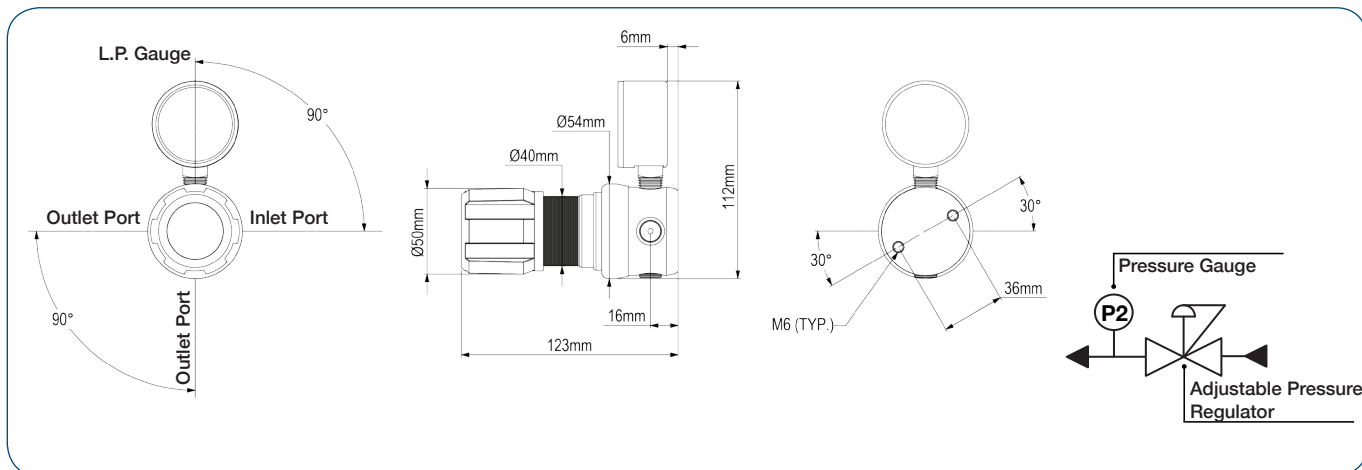

## MODEL NO. SELECTOR GUIDE

Example for a Model No. for SGL600 Series

Product Type	Inlet Pressure Bar [Psig]	Outlet Pressure Bar [Psig]	Inlet Pressure Gauge	Outlet Pressure Gauge	Inlet Connection	Outlet Connection	Options
SGL600	03 207 [3000]	02 0 to 1.5 [22]	00 No Gauge Fitted	00 No Gauge Fitted	000 1/4 NPT Female	00 1/4 NPT Female	A No Options Selected
		03 0 to 3.5 [50]		01 bar/PSI	001 1/8 Stainless Steel Compression	01 1/8 Stainless Steel Compression	F Bonnet Vent Capture Kit
		04 0 to 6 [90]		02 bar/PSI 3.1 Cert (Stainless Steel only) ***	002 1/4 Stainless Steel Compression	02 1/4 Stainless Steel Compression	G Helium Test Certificate
		05 0 to 10 [150]		10 Plugged port	003 6mm Stainless Steel Compression	03 6mm Stainless Steel Compression	H 3.1 Material Certificate***
					004 1/4 NPT Male	04 1/4 NPT Male	J NACE Certificate***
						09 Isolation Valve, 1/4 NPT Female, FKM Seal	K Certificate of Conformity (CoC)
						10 Isolation Valve, 1/4 NPT Female, EPDM Seal	L Panel Mount Locking Nut Kit
						11 Isolation Valve, 1/8 Stainless Steel Compression, FKM Seal	P Calibration/Pressure Test certificate
						12 Isolation Valve, 1/8 Stainless Steel Compression, EPDM Seal	X Special Instruction
						13 Isolation Valve, 1/4 Stainless Steel Compression, FKM Seal	
						14 Isolation Valve, 1/4 Stainless Steel Compression, EPDM Seal	
						15 Isolation Valve, 6 mm Stainless Steel Compression, FKM Seal	
						16 Isolation Valve, 6mm Stainless Steel Compression, EPDM Seal	
						17 Isolation Valve, 1/4 NPT Male, FKM Seal	
						18 Isolation Valve, 1/4 NPT Male, EPDM Seal	