



TECHNICAL SPECIFICATION

INPUT SPECIFICATION:

Input Types	Input	Range
	J	0 to 600 °C
K	0 to 999 °C	
Resolution	1 °C	
Indication Accuracy	±1% of FSD ± 1 °C (FSD:- Full Scale Deflection)	

DISPLAY AND KEYS:

Display	3 digit, 7 segment, 0.8" RED
Keys	SET, INC, DEC

DIMENSION:

Size (mm)	48 (H) x 48 (W) x 70 (D) mm
Panel Cutout	45 (H) x 45 (W) mm

CONTROL METHOD:

Heating	1) TP (Time Proportional)
	2) ON-OFF control

OUTPUT SPECIFICATION:

Relay Output	
Relay	1 Nos
Relay Type	1C/O (NO-C-NC)
Rating	10A, 230V AC / 28V DC
SSR Drive Output	
Output Signal	12V DC, 30mA DC (On-Off condition)

POWER SUPPLY:

Supply Voltage	100 to 270V AC, 50-60Hz
Power Consumption (VA Rating)	4VA @ 230V AC MAX

ENVIRONMENT CONDITION:

Operating Temp.	0 °C to 55 °C
Relative Humidity	UP to 95% RH (non-condensing)
Protection Level (As per request)	IP-65 (Front side) As per IS/IEC 60529 : 2001

MECHANICAL INSTALLATION

Outline Dimension (mm)	Panel Cutout Dimension (mm)

TERMINAL CONNECTION

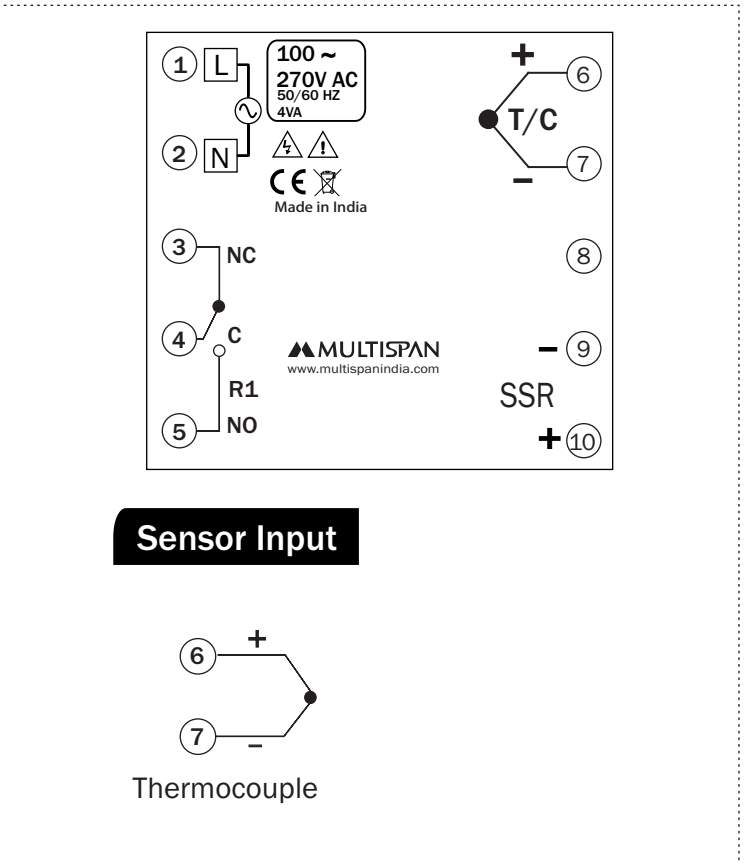

Sensor Input

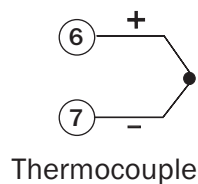

STATUS LED DESCRIPTION

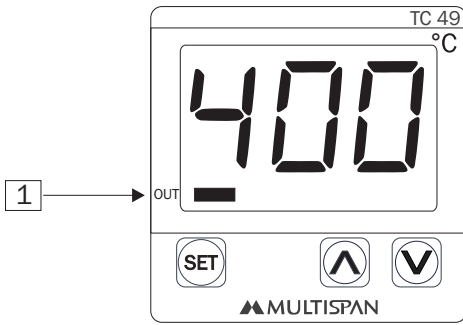

- 1 - Control output indication
- 2 - Auto tuning on indication

KEY OPERATION

FUNCTION	PRESS KEY
OPERATOR MODE	
To View Setpoint	Press & Hold
To Change Setpoint	+ /
To Enter in Parameter Setting mode	Press 5 sec
To Go into Factory Setting mode	+ Press 3 sec
PARAMETER SETTING MODE	
To set parameter value and move to next parameter	
To increment parameter value.	
To decrement parameter value.	
To save & exit From parameter setting mode	Press 3 sec



SAFETY PRECAUTION

All safety related codifications, symbols and instructions that appear in this operating manual or on the equipment must be strictly followed to ensure the safety of the operating personnel as well as the instrument.

If all the equipment is not handled in a manner specified by the manufacturer, it might impair the protection provided by the equipment.



Read complete instructions prior to installation and operation of the unit.



WARNING : Risk of electric shock.

WARNING GUIDELINES



WARNING : Risk of electric shock.

- To prevent the risk of electric shock, power supply to the equipment must be kept OFF while doing the wiring arrangement. Do not touch the terminals while power is being supplied.
- To reduce electro magnetic interference, use wire with adequate rating and twists of the same of equal size shall be made with shortest connection.
- Cable used for connection to power source, must have a cross section of 1mm or greater. These wires should have insulations capacity made of at least 1.5kV.
- When extending the thermocouple lead wires, always use thermocouple compensation wires for wiring for the RTD type, use a wiring material with a small lead resistance (5Ω max per line) and no resistance differentials among three wires should be present.
- A better anti-noise effect can be expected by using standard power supply cable for the instrument.

INSTALLATION GUIDELINES

- This equipment, being built-in-type, normally becomes a part of main control panel and in such case the terminals do not remain accessible to the end user after installation and internal wiring.
- Do not allow pieces of metal, wire clippings, or fine metallic fillings from installation to enter the product or else it may lead to a safety hazard that may in turn endanger life or cause electrical shock to the operator.
- Circuit breaker or mains switch must be installed between power source and supply terminal to facilitate power 'ON' or 'OFF' function. However this mains switch or circuit breaker must be installed at convenient place normally accessible to the operator.
- Use and store the instrument within the specified ambient temperature and humidity ranges as mentioned in this manual.

MECHANICAL INSTALLATION GUIDELINES

- Prepare the panel cutout with proper dimensions as shown above.
- Fit the unit into the panel with the help of clamp given.
- The equipment in its installed state must not come in close proximity to any heating source, caustic vapors, oil steam, or other unwanted process byproducts.
- Use the specified size of crimp terminal (M3.5 screws) to wire the terminal block. Tightening the screws on the terminal block using the tightening torque of the range of 1.2 N.m.
- Do not connect anything to unused terminals.

MAINTENANCE

- The equipment should be cleaned regularly to avoid blockage of ventilating parts.
- Clean the equipment with a clean soft cloth. Do not use isopropyl alcohol or any other cleaning agent.
- Fusible resistor must not be replaced by operator.

ERROR DISPLAY

When an error has occurred the display indicates error codes as given below.

ERROR	MEANING
OPn	Sensor is not connected or Over range condition or sensor break
SrE	Sensor connection is reversed

CORRECTIVE ACTION:

Check the sensor and the input wiring. If problem still exists, replace the sensor. And still if problem is not solved yet by the user, then please contact company person

FACTORY SETTING

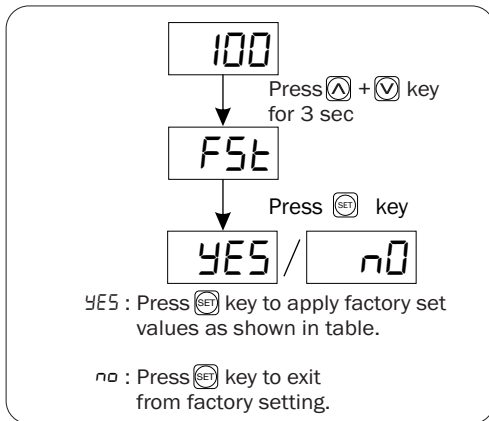

FACTORY SETTING		
SR.	PARAMETER	VALUES
1	Hysteresis	3 °C
2	Offset	0 °C
3	PB2	5 °C
4	Ct2	8 sec
5	MR	0 °C

PARAMETER RANGE

SR.	PARAMETER	RANGE
1	Hysteresis	1 to 100 °C
2	Offset	-20 to +20 °C
3	PB2	2 to 20 °C
4	Ct2	4 to 99 Sec
5	MR	-9 to 9 °C

PARAMETER SETTING

Set Point Setting

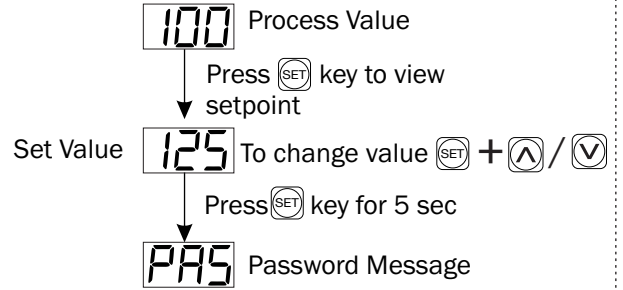

Basic Configuration

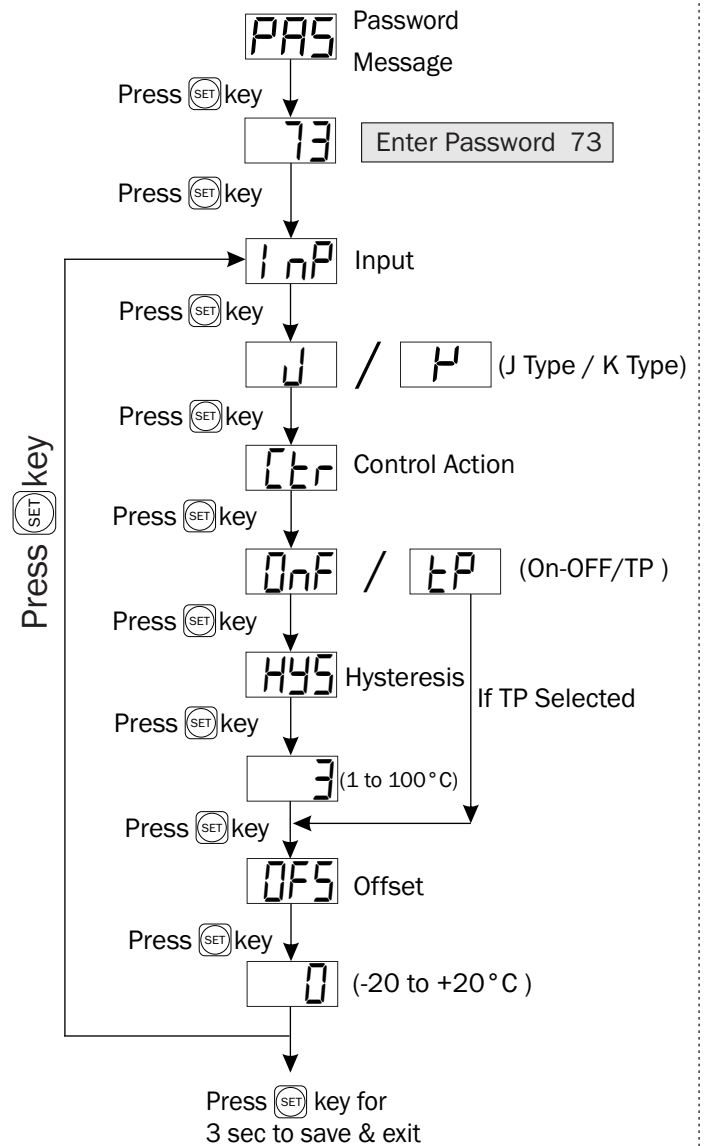

PARAMETER SETTING

Control Parameter

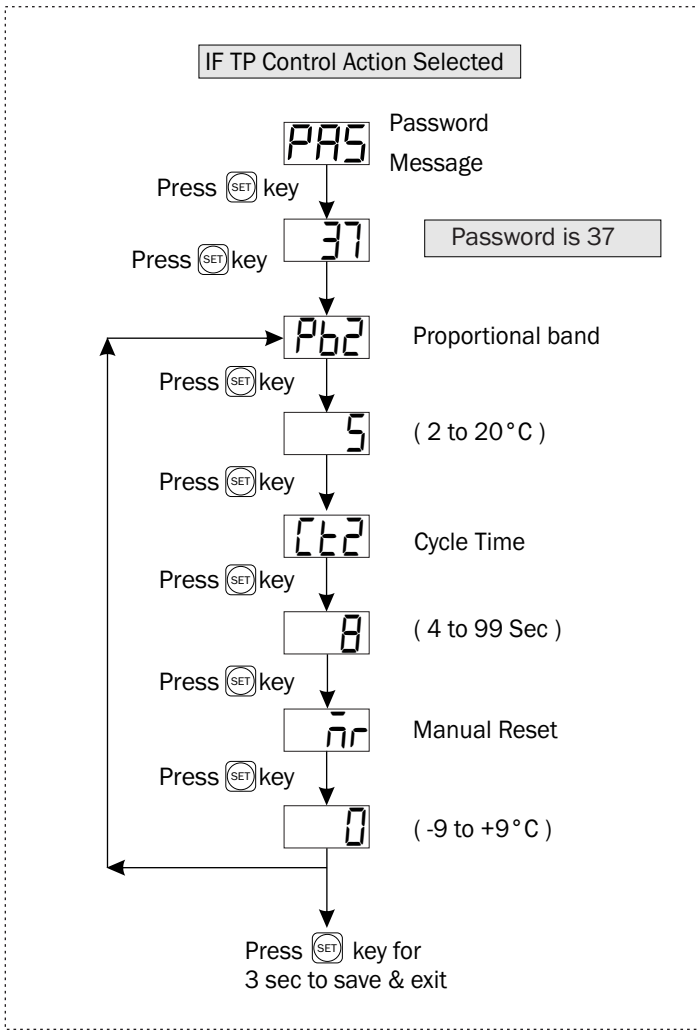

CONTROL FUNCTION

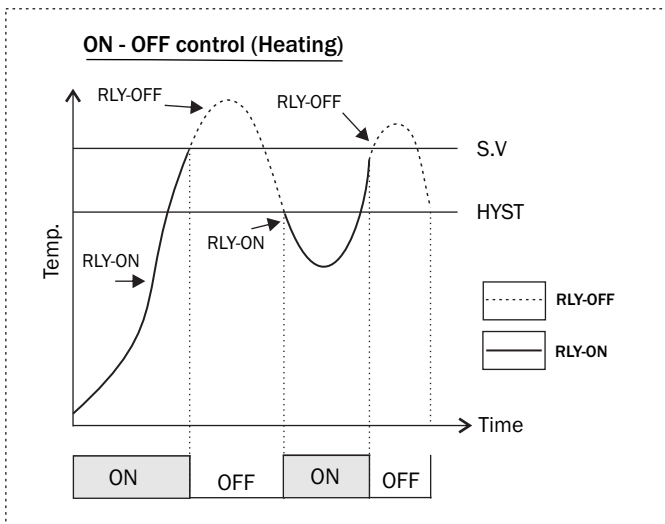

Specifications are subject to change, since development is a continuous process.
 So for more updated operating information and Support,
 Please contact our Helpline: 9978991476/9978991482/9978991474 or
 Email at service@multispanindia.com Ver:200206