

UNIVERSAL TIMER

UTR-4244 Manual



AUXILIARY SUPPLY:

Supply voltage	100 to 270V AC, 50-60Hz
Power consumption (VA RATING)	Approx 4 VA @ 230V AC MAX

ENVIRONMENT CONDITION:

Operating Temp.	0 °C to 55 °C
Relative Humidity	UP to 95% RH (non-condensing)
Protection Level (AS Per Request)	IP-65 (Front side) As per IS/IEC 60529 : 2001

TECHNICAL SPECIFICATION

Input (Start Pulse)	NPN/PNP Proximity
	Micro Switch
	Limit Switch
Time Range	Sec (9.999/999.9/9999)
	Min (99.59/999.9/9999)
	Hour (99.59/999.9/9999)

DISPLAY AND KEYS:

Display	Upper: 4 digit, 7 segment, 0.70" Red Lower: 4 digit, 7 segment, 0.50" Green
Keys	SET/ENT, SHIFT, INC, RESET

DIMENSION:

Size	48 (H) x 48 (W) x 70 (D) mm
Panel Cutout	45 (H) x 45 (W) mm

GENERAL SPECIFICATION:

Operating Mode	Forward - Reverse Timer
	Cyclic Timer
	Sequential Timer
	Combination Timer
Counting Direction	UP/ DOWN
Reset Option	Front Panel Reset
	Terminal Reset

OUTPUT SPECIFICATION:

Relay Output	
Relay	2 nos.
Relay Type	1 C/O (NO-C-NC)
Rating	5A, 230V AC

MECHANICAL INSTALLATION

Panel Cutout Dimension (mm)

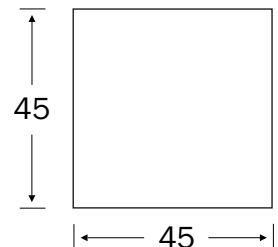

Outline Dimension (mm)

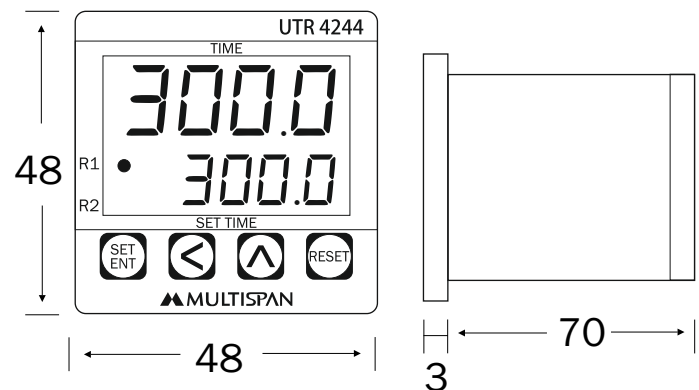

TERMINAL CONNECTION

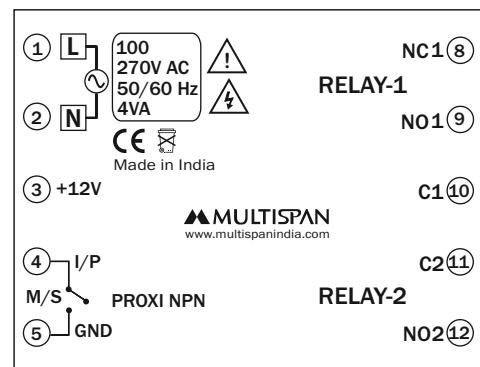

STATUS LED DESCRIPTION

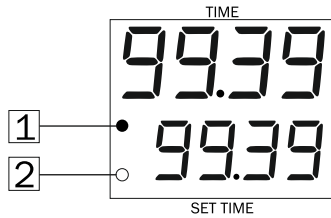

- 1 - Relay 1 control output
- 2 - Relay 2 control Output

PROXY COLOURS CODE

+12V	OUTPUT	GND
Brown	Black	Blue
Red	Green	Black

KEY OPERATION

FUNCTION	PRESS KEY
OPERATOR MODE	
To enter in parameter setting mode	Press Key along with power on device
To reset the timer	
PARAMETER SETTING MODE	
Edited parameter value to be set, And move to the next parameter	
It will select the digit to modify, When value is edited	
It will change the Value of selected digit	

INSTALLATION GUIDELINES

- This equipment, being built-in-type, normally becomes a part of main control panel and in such case the terminals do not remain accessible to the end user after installation and internal wiring.
- Do not allow pieces of metal, wire clippings, or fine metallic fillings from installation to enter the product or else it may lead to a safety hazard that may in turn endanger life or cause electrical shock to the operator.
- Circuit breaker or mains switch must be installed between power source and supply terminal to facilitate power 'ON' or 'OFF' function. However this mains switch or circuit breaker must be installed at convenient place normally accessible to the operator.
- Use and store the instrument within the specified ambient temperature and humidity ranges as mentioned in this manual.

MECHANICAL INSTALLATION GUIDELINES

- Prepare the panel cutout with proper dimensions as shown above.
- Fit the unit into the panel with the help of clamp given.
- The equipment in its installed state must not come in close proximity to any heating source, caustic vapors, oils steam, or other unwanted process byproducts.
- Use the specified size of crimp terminal (M3.5 screws) to wire the terminal block. Tightening the screws on the terminal block using the tightening torque of the range of 1.2 N.m.
- Do not connect anything to unused terminals.

MAINTENANCE

- The equipment should be cleaned regularly to avoid blockage of ventilating parts.
- Clean the equipment with a clean soft cloth. Do not use isopropyl alcohol or any other cleaning agent.
- Fusible resistor must not be replaced by operator.

! SAFETY PRECAUTION

All safety related codifications, symbols and instructions that appear in this operating manual or on the equipment must be strictly followed to ensure the safety of the operating personnel as well as the instrument.

If all the equipment is not handled in a manner specified by the manufacturer, it might impair the protection provided by the equipment.



Read complete instructions prior to installation and operation of the unit.



WARNING : Risk of electric shock.

WARNING GUIDELINES



WARNING : Risk of electric shock.

- To prevent the risk of electric shock, power supply to the equipment must be kept OFF while doing the wiring arrangement. Do not touch the terminals while power is being supplied.
- To reduce electro magnetic interference, use wire with adequate rating and twists of the same of equal size shall be made with shortest connection.
- Cable used for connection to power source, must have a cross section of 1mm or greater. These wires should have insulations capacity made of at least 1.5kV.
- A better anti-noise effect can be expected by using standard power supply cable for the instrument.

SEQUENTIAL TIMER

Relay-1 setting

dL-1(Delay time)= 5 sec
 on-1(On time)= 10 sec
 of-1(Off time)= 5 sec
 cyc(Total no. of repeat cycle of Relay 1 & Relay 2)= 1

Relay-2 setting

dL-2(Delay time)= 10 sec
 on-2(On time)= 20 sec
 of-2(Off time)= 10 sec

 - This symbol in all graph will represent Relay is On

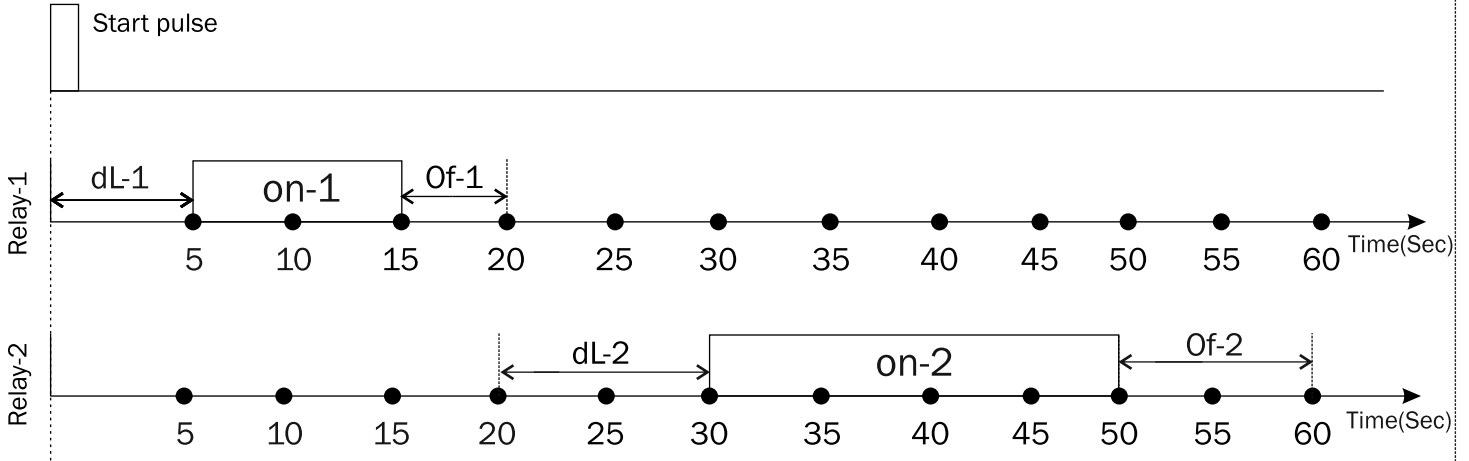

COMBINATION TIMER

Relay-1 setting

d1c1(Delay Time Of Relay 1 & cycle 1)= 5 sec
 r1c1(Relay on time Of Relay 1 & cycle-1)=10 sec
 d1c2(Delay Time Of Relay 1 & cycle 2)= 5 sec
 r1c2(Relay on time Of Relay 1 & cycle-2) = 10 sec
 Cyc1(Relay 1 combination) = 2
 nocl(Total no. of Relay-1 & Relay-2 Combination)=2

Relay-2 setting

d2c1(Delay Time Of Relay 2 & cycle 1)= 5 sec
 r2c1(Relay on time Of Relay 2& cycle-1)= 10 sec
 d2c2(Delay Time Of Relay 2 & cycle 2)= 10 sec
 r2c2(Relay on time Of Relay 2& cycle-2) = 10 sec
 Cyc2(Relay 2 combination) = 2

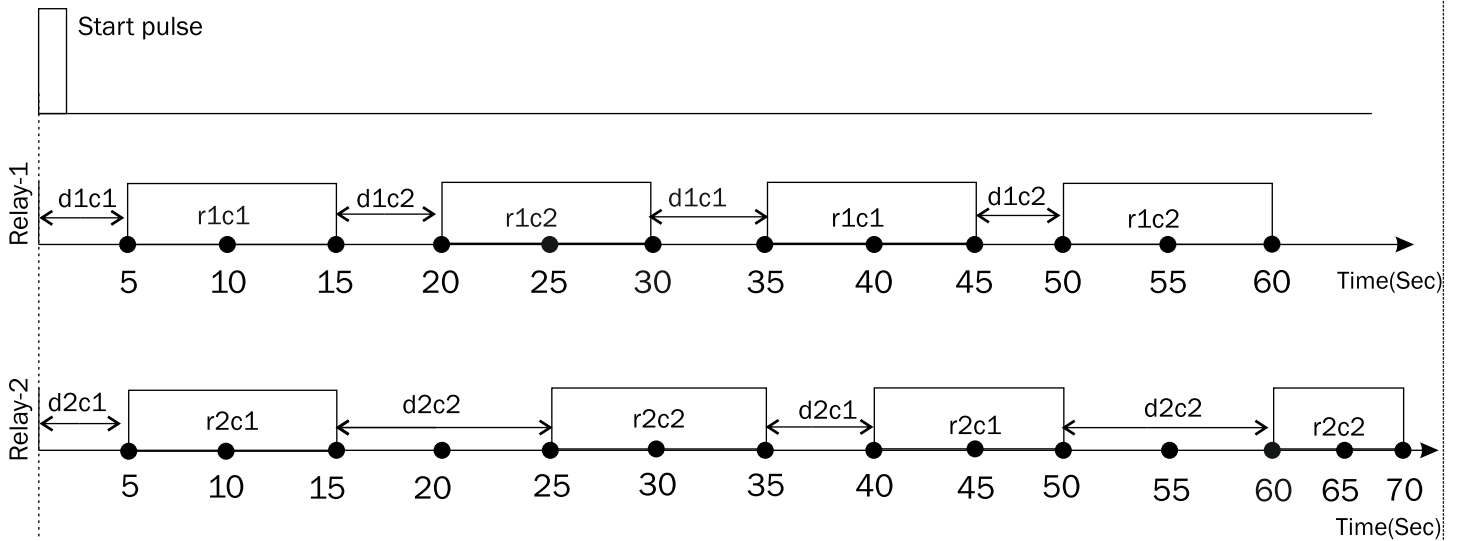

FORWARD REVERSE TIMER

Forward Time (Frtm) = 10 SeC
 Stop Time (Sttm) = 5 Sec
 Reverse Time (rvtm) = 10 Sec
 Total Time (totl) = 1 min

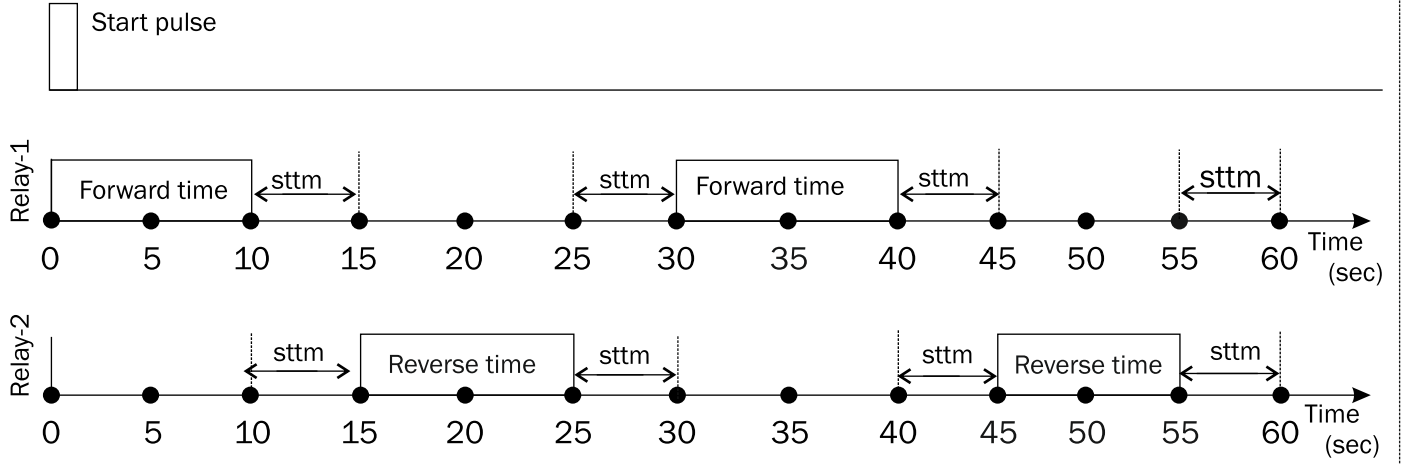

CYCLIC TIMER

on time (ontm)= 5 sec
 off time (oftm)= 10 sec

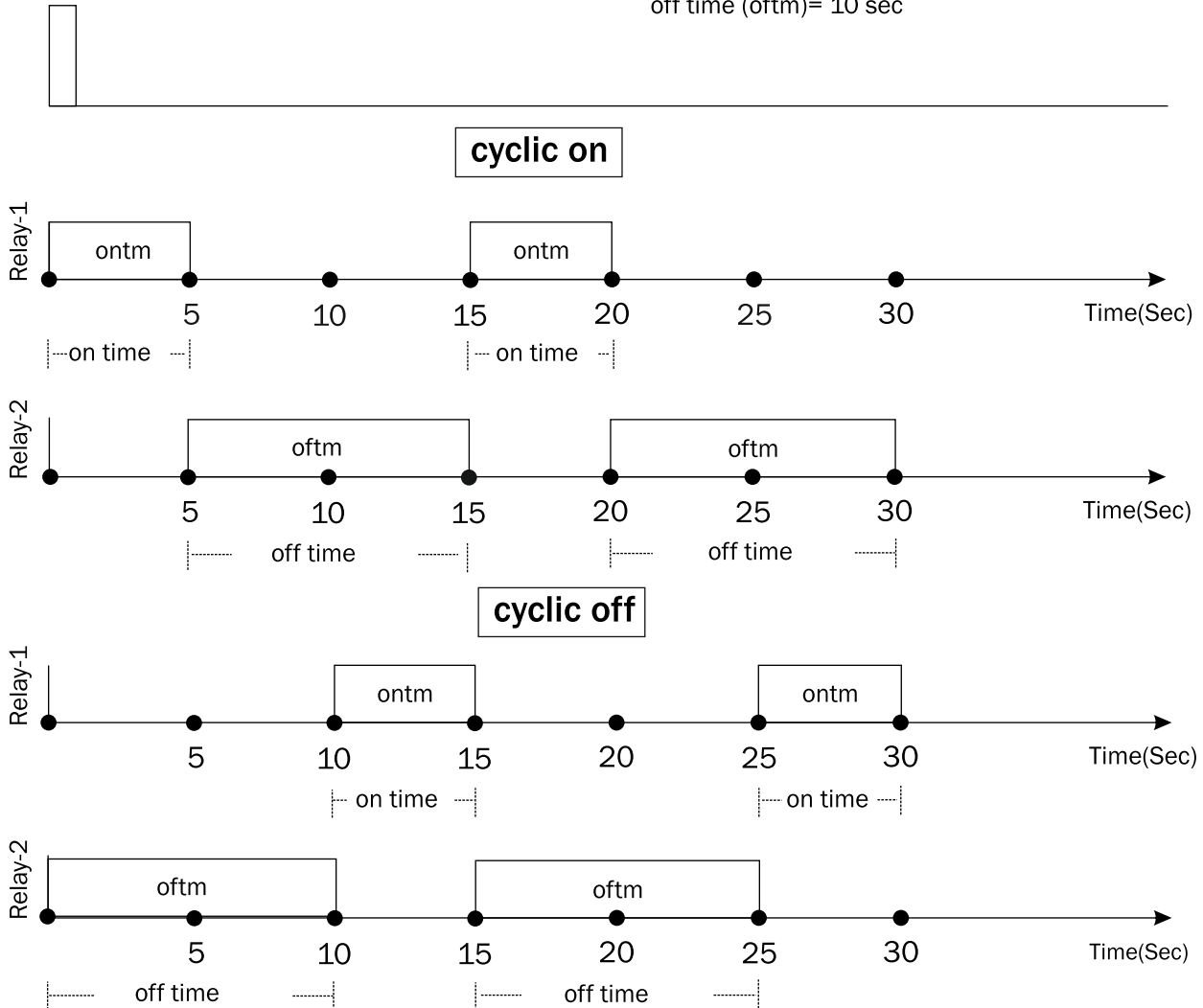

PARAMETER SETTING

To Enter in Parameter Setting mode
Press & Hold **⏻** Key along with power on Device

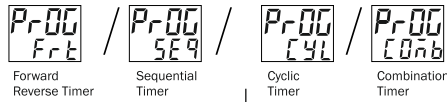

Select the operating mode and Restart the device

FRT (Forward Reverse Timer)

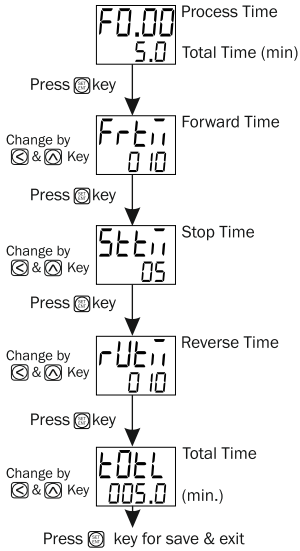

Press **⏻** key for 15 Sec to go into Detailed parameter

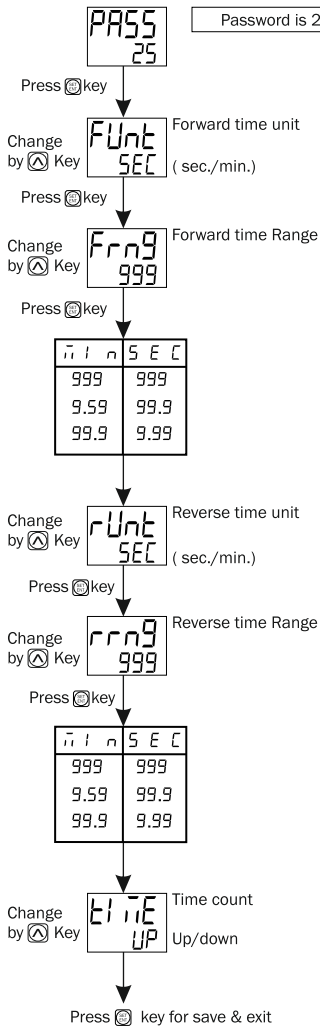

SEQ (Sequential Timer)

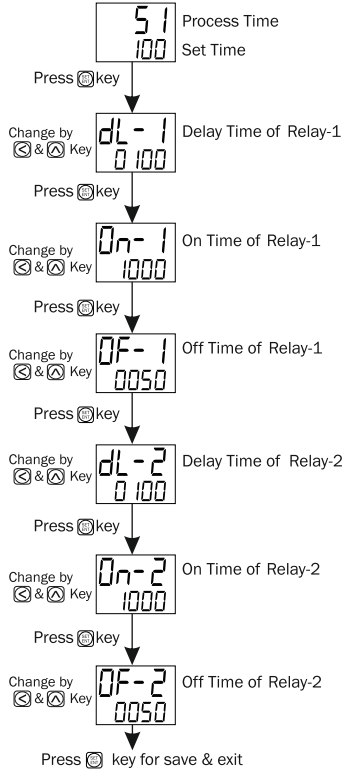

Press **⏻** key for save & exit

Press **⏻** key for 15 Sec to go into Detailed parameter

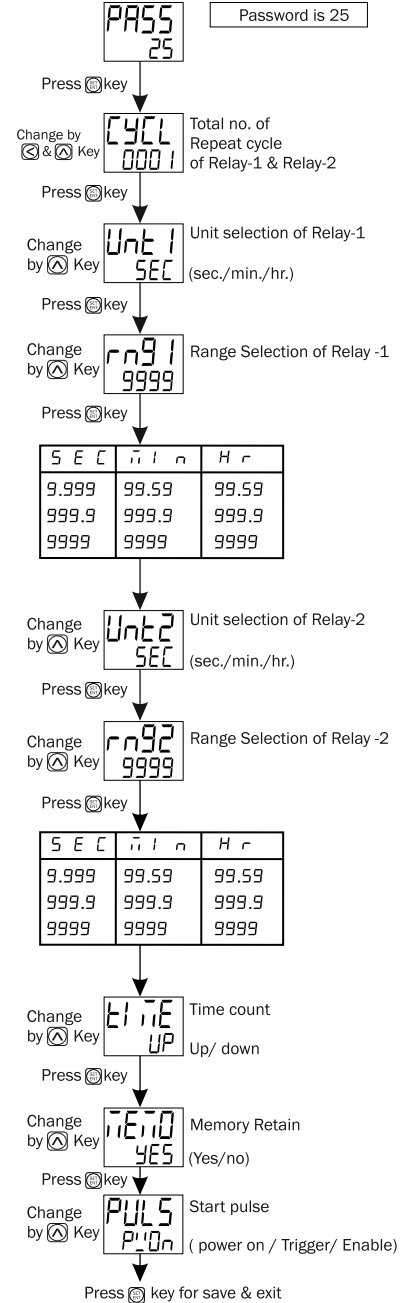

Press **⏻** key for save & exit

PARAMETER SETTING

