



Min. Mark Output Delay	20 ms
Operating Temp.	-10 to 50 C
Storage Temp.	-20 to 70 C
Operating Distance	10 to 15 mm
Minimum Spot Diameter	5 mm
Emission type	RED (630 nm) GREEN (520 nm) BLUE (465 nm)
Ambient Light Rejection	Yes
Vibration	0.5 mm amplitude, 10 to 55 Hz Frequency
Housing Material	ABS
Lens Material	Glass
Connection	Shielded 4 Wire Cable

FEATURES

- Ultra fast response
- Unmatched accuracy with multi-color sensing
- Compact & sleek design
- Standard mounting for easy installation
- Ambient light noise rejection for better colour recognition
- Scratch resistance lens for dusty applications

Technical Specification

Model	CMS 5X
Power Supply	12 - 24V DC
Current Consumption	35 mA max.@ 24 V DC
Output	NPN/PNP Output
Output Current	25 mA max
Response Time	2 Milisecond
Indications	LED 1 : Mark LED(Green) LED 2 : Output LED(Red) LED 3 : Background LED (Yellow)
Push Buttons	Button 1 : Mark Button Button 2 : Background Button

User Interface

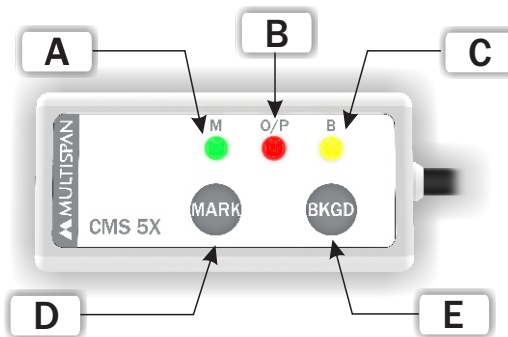

- A** - Mark LED: LED blinks When mark teaching is in process
- B** - Output LED: LED turns "ON" When mark is recognised
- C** - Background LED: LED Blinks when background teaching is in process
- D** - Mark teach key: Press for 3 sec. to teach the mark colour to CMS
- E** - Background teach key: Press for 3 sec. to the background colour to CMS

Mark Teaching

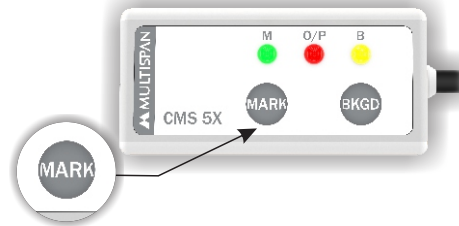

- Align the light spot on the mark then press the mark key for 3 sec.to teach the mark colour to CMS.
- Wait till all the 3 colour (R-G-B) sensing is automatically completed.
- The Mark LED will continuously blink till the mark teaching is in process as soon as the mark teaching is completed the background LED will start blinking for background sensing.

Background Teaching

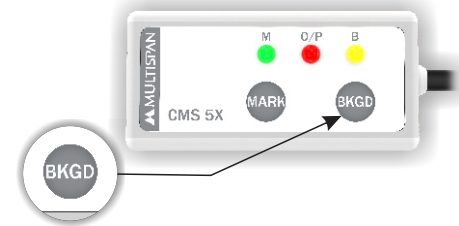

- Align the light spot on the background (non-mark area) then press the background key for 3 sec. to teach the background colour to CMS.
- Wait till all the 3 colour (R-G-B) sensing is completed.
- The background LED will continuously blink till the background teaching is in process as soon as the background teaching is completed the background LED will turn "OFF".

Electrical Connection & Pinout

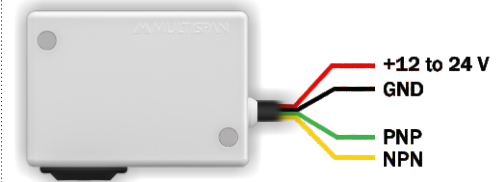

Pinout:

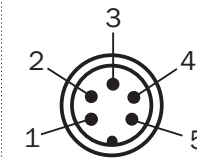

- 1. +12 to +24 V
- 2. GND
- 3. NPN
- 4. PNP
- 5. Not Connected

Sensing Glossy Surface

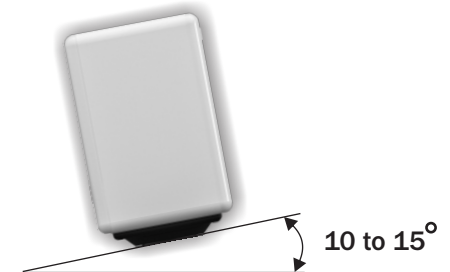

- Object with a glossy surface have a large amount of specular reflection particles that may destabilize sensing. In such a case, by slightly tilting the sensor,the output can be more stable.
- If the surface of the sensing object has a shine,mount the sensor inclining approx. 10 to 15 degrees against the packaging material.

Precautions For Proper Wiring

- Take care that wrong wiring will damage the sensor.
- Verify that the supply voltage variation is within the rating.
- Do not use during the initial transient time (3 sec.) after the power supply is switched on.
- Do not run the wires together with high-voltage lines or power lines. This can cause malfunction due to induction.
- Take care that short-circuit of the load or wrong wiring may burn or damage the sensor.
- However, in order to reduce noise, make the wiring as short as possible.

Precautions For Proper Use

- Take care that the sensor is not directly exposed to fluorescent light from a rapid-starter lamp or a high frequency light device or sunlight etc., as it may affect the sensing performance.
- Do not touch the lens of the sensor by hand directly. If the lens becomes dirty, wipe it off with a soft cloth gently.
- Do not use this sensor in places having excessive vapor, dust, etc., or where it may come in direct contact with water, or corrosive gas. It may damage the sensor.
- Take care that the product does not come in contact with water, oil, grease, or organic solvents, such as, thinner, etc.
- This sensor cannot be used in an environment containing inflammable or explosive gases.
- Never disassemble or modify the sensor otherwise the warranty will be void.

Dimension

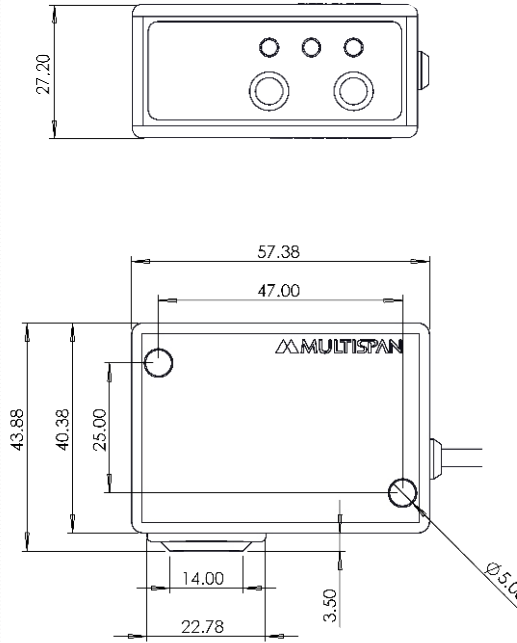

All Dimensions are in mm(Millimeter)

Spot Characteristics

NOTE : The spot dimension will change according to the distance between sensor and the packaging material.

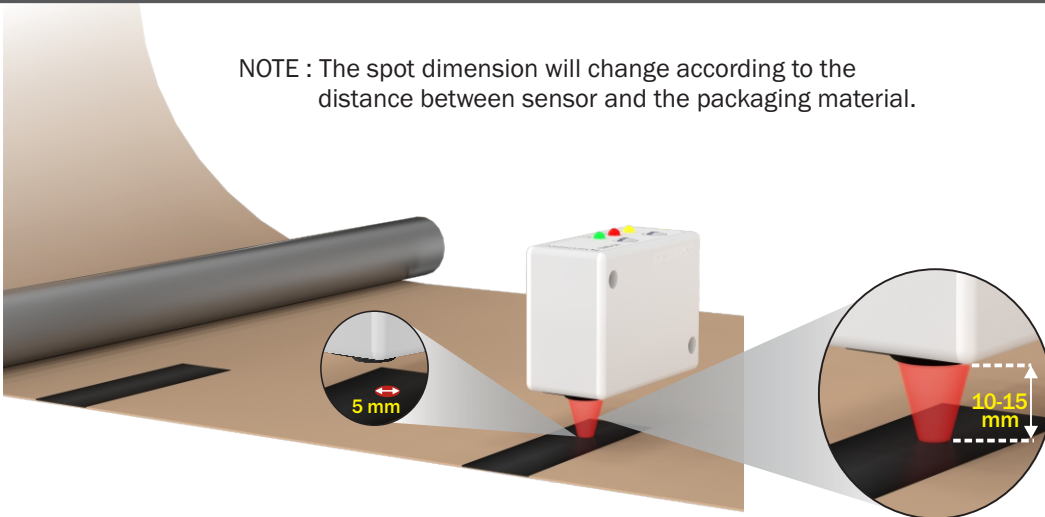

Multispan reserves the right to change specifications without prior notice. Printing and typographical errors reserved. Product improvement and upgrade is a constant procedure. So for more updated operating information & support. Please contact our Helpline: +91-9081078683 or Email At service@gmail.com

Multispan Control Instruments Pvt. Ltd.

72/B, Phase 1, GIDC Estate, Vatva, Ahmedabad-382445, Gujarat, India.
☎ +91-9081078683/9978990114/9978991479
✉ marketing@multispanindia.com

Follow us

PROUDLY
MADE IN
INDIA
www.multispanindia.com