

# Rubine™

— I T A L I A —

**LEAD THE CHANGE**



Energy Saving  
Inverter DC Silent Pump  
Penjimatan Tenaga  
Pam Senyap Inverter DC



LOW NOISE AC PUMP  
INVERTER TECHNOLOGY  
TEKNOLOGI INVERTER PAM AC  
OPERASI SENYAP



DWI SALURAN ELCB  
DWI HAD BATASAN PEMANAS

**WATER HEATER / PEMANAS AIR**

**USER MANUAL / PANDUAN PENGGUNA**

MODEL / MODEL

FORTE SERIES (F191D / F192A / F190N)

Please read this manual thoroughly and understand the content before use.

*Sila baca panduan ini dengan teliti dan memahami isi kandungannya sebelum penggunaan.*



## **SAFETY PRECAUTION** **LANGKAH-LANGKAH KESELAMATAN**

1. Do not install reverse INLET & OUTLET and Stop Valve of heater.  
*Jangan memasang "INLET & OUTLET" dan Injap Hentian pemanas dalam keadaan songsang.*
2. Do not install the heater where there is consistent spray directly over the unit.  
*Jangan memasang pemanas air dimana terdapat semburan konsisten terus ke atas unit.*
3. Do not connect the OUTLET to any tap or fitting that is not recommended by the manufacturer.  
*Jangan sambungkan "OUTLET" pada mana-mana paip atau pemasangan yang tidak disyorkan oleh pengeluar.*
4. Do not block the heater OUTLET in any way.  
*Jangan menghalang "OUTLET" pemanas dalam apa jua cara.*
5. Do not attempt to repair the heater without qualified technician.  
*Jangan cuba untuk membaiki pemanas tanpa juruteknik yang berkelayakan.*
6. This appliance is not intended for use by person (including children) with reduced physical, sensory or mental capabilities, or lack of experience and knowledge, unless they have been supervision or instuction concerning use of the appliance by a person responsible for their safety.  
*Perkakas ini tidak digalakkan untuk digunakan oleh orang (termasuk kanak-kanak) kurang upaya darisegi fizikal, deria atau mental, atau kurang berpengalaman atau pengetahuan, kecuali mereka diawasi atau diberi arahan mengenai penggunaan perkakas ini oleh orang yang bertanggungjawab keatas keselamatan mereka.*
7. Children should be supervised to ensure that they do not play with the appliance.  
*Kanak-kanak hendaklah diselia untuk memastikan mereka tidak bermain dengan perkakas ini.*

8. Engage qualified electrician for installation.  
*Gunakan juruelektrik yang berkeelayakan untuk pemasangan.*
9. Test water temperature with hand before using the shower.  
*Uji suhu air dengan menggunakan tangan sebelum menggunakan pemanas air.*
10. Check the ELCB once a month (please refer to the Test Run of Heater) and consult professional for repair if there is any malfunction.  
*Pastikan ELCB diperiksa setiap bulan (sila rujuk Pengujian Pemanas) dan hubungi juruteknik untuk sebarang pembaikan.*
11. Metallic / chrome flexible hose and conductive control valve shall not be used.  
*Saluran getah logam / krom dan injap kawalan konduktif tidak boleh digunakan.*
12. Do not leave the hand shower idle in the pail. (refer below)  
*Jangan meninggalkan alat pancuran terbiar di dalam baldi. (rujuk dibawah)*

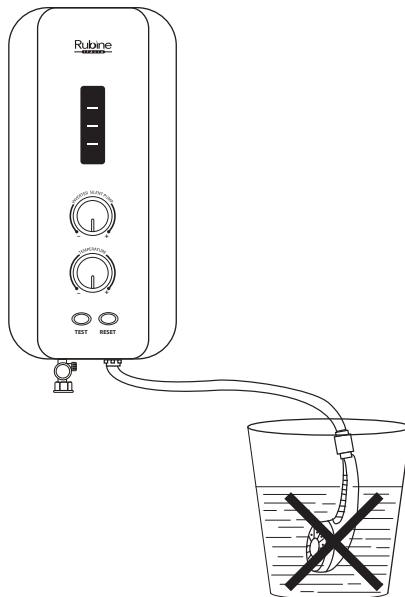

# 1. WATER HEATER PARTS IDENTIFICATION

## PENGENALAN BAHAGIAN – BAHAGIAN PEMANAS AIR

### EXTERNAL PARTS IDENTIFICATION

#### PENGENALAN BAHAGIAN LUARAN

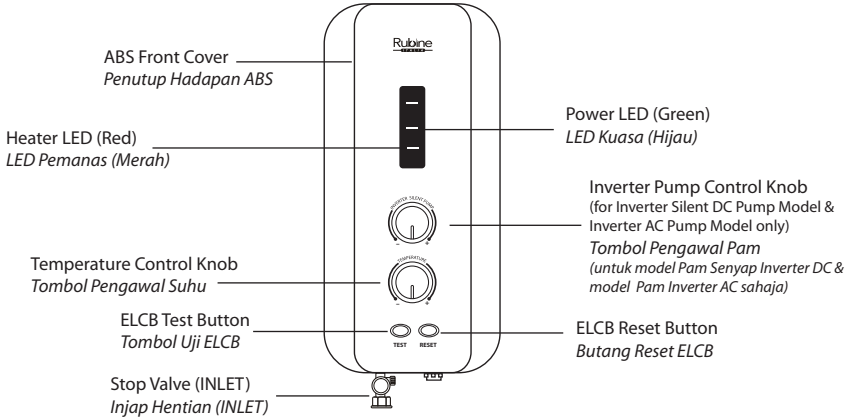

### INTERNAL PARTS IDENTIFICATION

#### PENGENALAN BAHAGIAN DALAMAN

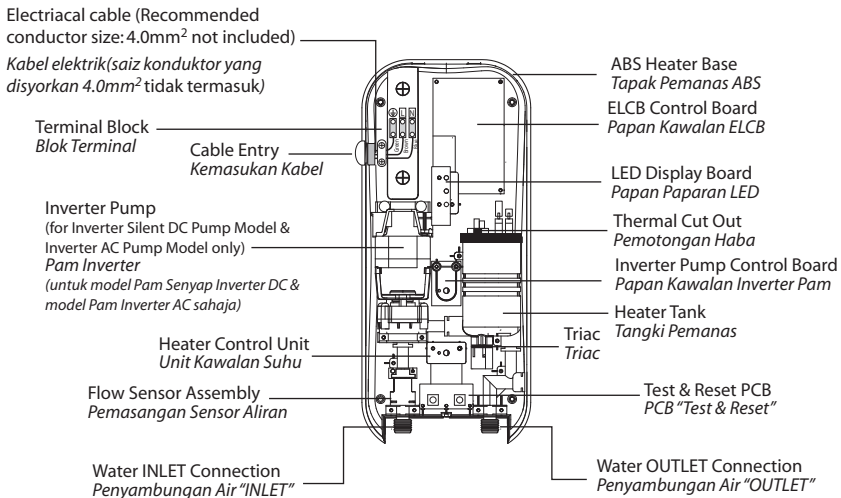

**SHOWER SET ACCESSORIES IDENTIFICATION**  
**PENGENALAN AKSESORI PANCURAN**

**1. WHITE / BLACK ACCESSORIES**  
**AKSESORI PUTIH/ HITAM**

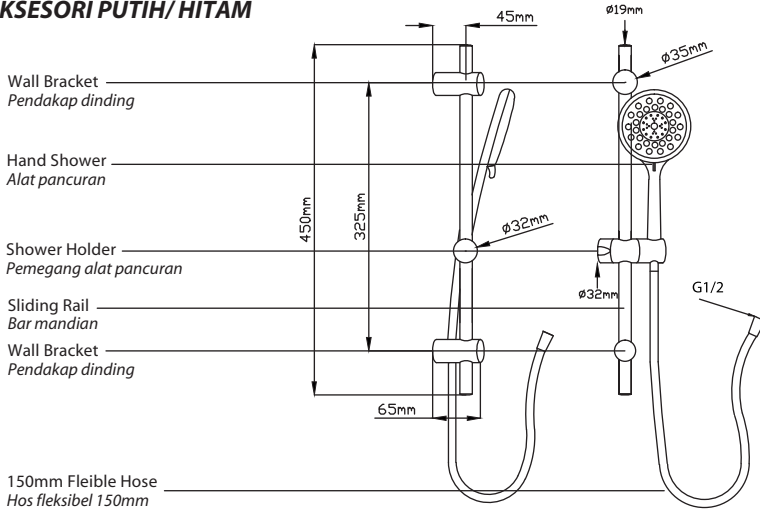

**2. CHROME ACCESSORIES**  
**AKSESORI KROM**

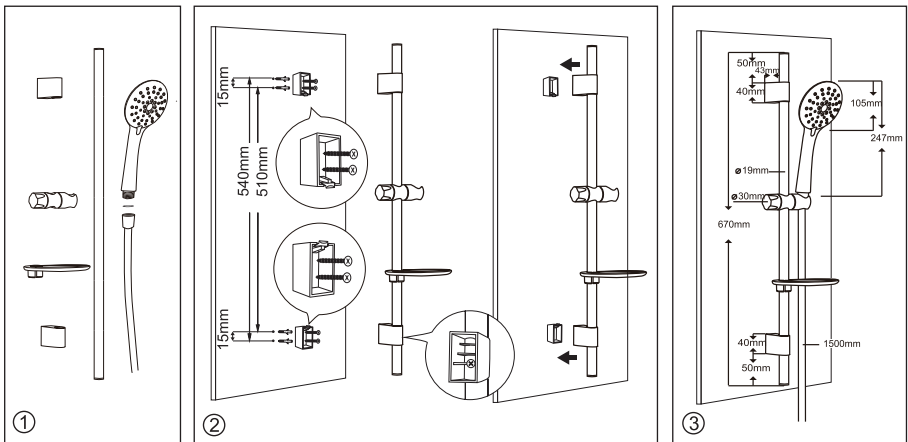

**3. RAIN SHOWER SET (Optional Features)**  
**SET PANCURAN MANDIAN HUJAN (Ciri-ciri pilihan)**

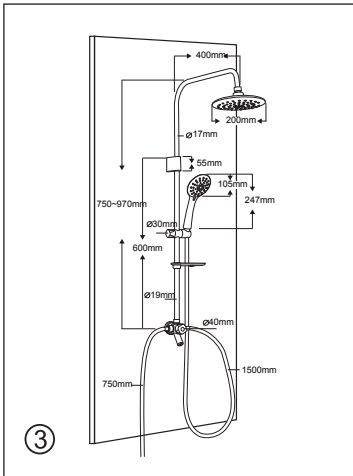
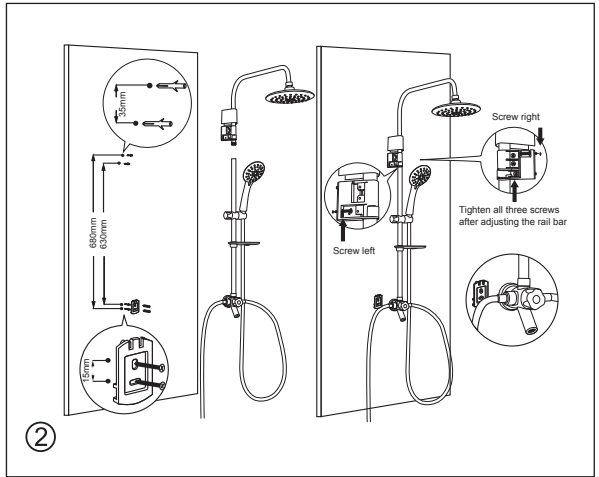
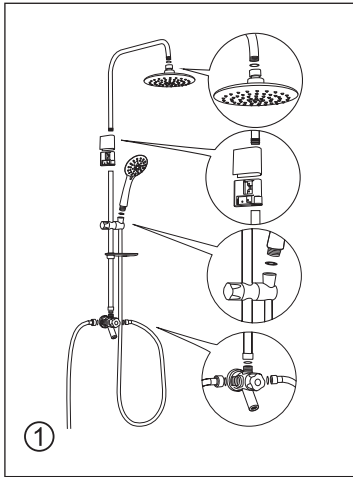

## 2. GENERAL INFORMATION

### MAKLUMAT UMUM

#### INSTALLATION

#### PEMASANGAN



**CAUTION:**  
**AWAS:**  
**THIS APPLIANCE MUST BE EARTHED**  
**PERKAKAS INI MESTI DIBUMIKAN**

1. All the plumbing work should be completed before proceeding to electrical wiring connection. (Table 1)  
*Semua pemasangan paip perlu diselesaikan sebelum memulakan kerja-kerja penyambungan wayar elektrik. (Jadual 1)*
2. Installation must be carried out by qualified electrician with close reference to this manual and in compliance with the local regulations.  
*Pemasangan mestilah dilakukan oleh juruteknik yang berkelayakan dengan merujuk pada panduan ini dan mengikut akta-akta tempatan.*
3. The unit works at minimum water flow rate of 2 litre/min, which then would trigger the built-in pump (only for pump model), boosting a stronger shower spray.  
*Unit ini berfungsi pada kadar aliran air minima 2 liter/min, yang mengaktifkan pam dan kemudiannya meningkat pancuran semburan.*
4. The built-in electronic Earth Leakage Circuit Breaker (ELCB) would cut-off the power supply to heater in the event of current leakage of as low as 15mA.  
*"Earth Leakage Circuit Breaker (ELCB)" akan memutuskan bekalan kuasa sekiranya berlaku kebocoran tenaga serendah 15mA.*
5. The Thermal Cut-Off would automatically shut off the power supply shall there is any abnormal rise of showering temperature.  
*Pemotongan haba berfungsi secara automatik akan memutuskan bekalan kuasa jika terdapat kenaikan suhu secara tidak normal.*
6. The unit only operates when there is sufficient water flow to trigger the flow switch.  
*Unit hanya akan beroperasi apabila terdapat aliran air yang cukup untuk mengaktifkan suis aliran.*

7. Electrical loading Table 1:  
*Pendawaian elektrik Jadual 1:*

Voltage (Vac)	Power (kW)	Amperes (A)	Recommended Conductor Size (csa)			Fuse/ MCB(A)	ON/OFF Switch (A)
			mm <sup>2</sup>	Conduit Cable	Flexible Cable		
220 - 50/60Hz	3.5	16.0	2.5	7/0.67mm	50/0.25	20	20
	4.5	20.5	2.5	7/0.67mm	56/0.30	25	25
	5.5	25.0	4.0	7/0.85mm	56/0.30	32	32
	6.0	27.3	4.0	7/0.85mm	56/0.30	32	32
	6.5	29.6	4.0	7/0.85mm	84/0.30	32	32
	7.5	34.1	6.0	7/1.04mm	84/0.30	40	40
	8.0	36.4	6.0	7/1.04mm	84/0.30	40	40
230 - 50/60Hz	3.5	15.2	2.5	7/0.67mm	50/0.25	20	20
	5.5	24.0	4.0	7/0.85mm	56/0.30	32	32
	6.6	28.7	4.0	7/0.85mm	56/0.30	32	32
	8.8	28.3	6.0	7/1.04mm	84/0.30	40	40
240 - 50/60Hz	3.6	15.0	4.0	7/0.85mm	56/0.30	32	32
	4.2	17.5	4.0	7/0.85mm	56/0.30	32	32
	7.7	32.1	6.0	7/1.04mm	84/0.30	40	40
	9.0	37.5	6.0	7/1.04mm	84/0.30	40	40

8. Instantaneous water heater shall be equipped with a 2-pole control switch and own residual current device.  
*Pemanas air segera hendaklah dilengkapi dengan kawalan suis 2-kutub dan memiliki peranti arus berbaki.*
9. Water heaters exceeding 3kW shall be permanently connected to a 20A/30A rated circuit breaker/fuse with an isolator switch and residual current device.  
*Pemanas air yang melebihi 3kW hendaklah disambung secara tetap pada 20A/30A nilai arus pemutus litar/fius dengan suis pengasing dan peranti arus berbaki.*

### 3. INSTALLATION PROCEDURES **TATACARA PEMASANGAN**

1. INLET and OUTLET connection of the heater unit should not be reversed, with stop valve installed on INLET. (Diagram 1)  
*Sambungan unit pemanas "INLET" dan "OUTLET" tidak boleh songsang dan injap hentian mestilah di pasang pada "INLET".*
2. It is recommended that the unit should be mounted above 1.5m above the floor to bottom of the heater. (Diagram 1)  
*Pemasangan unit digalakkan mempunyai jarak 1.5m antara lantai dengan bahagian bawah pemanas. (Rajah 1)*

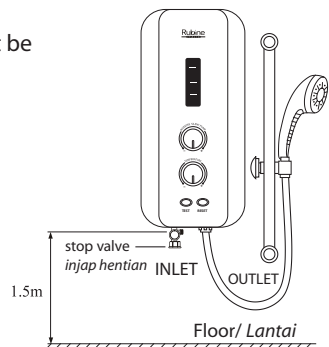

Diagram 1  
Rajah 1



### 3. Mounting position

#### Penetapan tapak pemanas

- Remove screw at the bottom of the heater  
*Keluarkan skru dari bawah pemanas*
- Lift the plastic cover upward (Refer Diagram 2)  
*Buka penutup plastik pemanas dari bahagian bawah. (Rujuk Rajah 2)*
- Mark mounting position on the wall for all 4 screws  
*Tandakan posisi semua 4 skru pada dinding*
- Drill the holes with 5.0mm diameter drill bit  
(Refer Diagram 3)  
*Gerudi lubang dengan menggunakan bit gerudi berdiameter 5.0mm (Rujuk Rajah 3)*
- Install the unit to the wall with plug  
*Pasang unit pada dinding bersama plug*

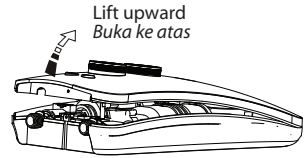
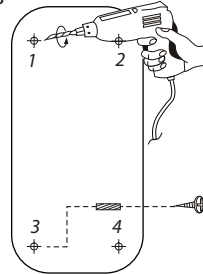

Diagram 2  
Rajah 2



#### WARNING !

To prevent vibration, all 4 screw must be tightened fully.  
*Untuk mengelakkan getaran, semua 4 skru hendaklah diketatkan sepenuhnya.*

Diagram 3  
Rajah 3

### 4. Installation of Heater INLET and OUTLET connection. (Diagram 4)

#### Pemasangan "INLET" dan "OUTLET" pemanas. (Rajah 4)

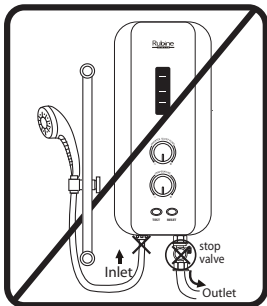
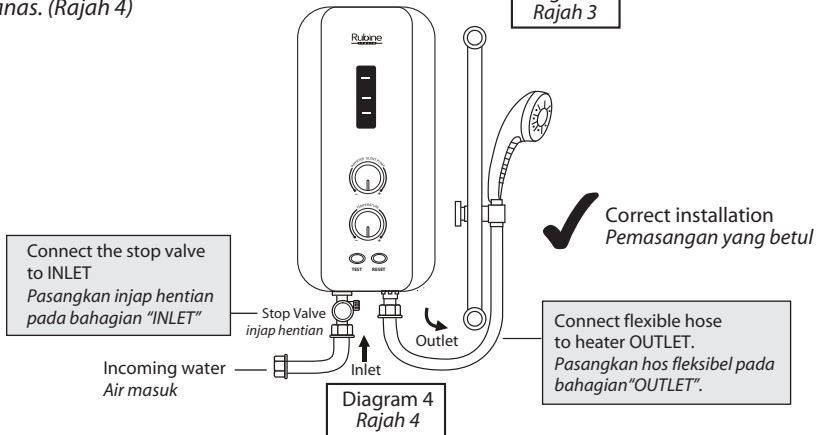

**X** inlet - outlet reverse  
*(wrong installation)*  
inlet - outlet songsang  
*(pemasangan yang salah)*

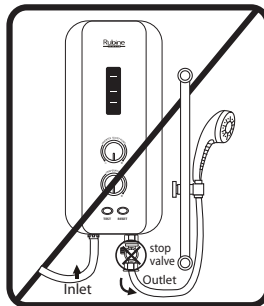

**X** stop valve reverse  
*(wrong installation)*  
inlet - outlet songsang  
*(pemasangan yang salah)*

5. Electrical Connection  
*Penyambungan elektrik*

**IMPORTANT NOTE !**  
**NOTA PENTING !**

SWITCH OFF THE MAIN SUPPLY BEFORE ELECTRICAL WORK  
*PADAMKAN SUIS UTAMA SEBELUM MELAKUKAN KERJA-KERJA  
PENDAWAIAN ELEKTRIK*

- a) Insert electrical cable through the rubber grommet as (Diagram 5).  
*Masukkan kabel elektrik melalui grommet getah seperti yang ditunjukkan pada (Rajah 5).*
- b) Connect the cable to the terminal block and fully tighten as below :  
*Sambungkan kabel ke blok terminal dan ketatkan sepenuhnya seperti berikut:*

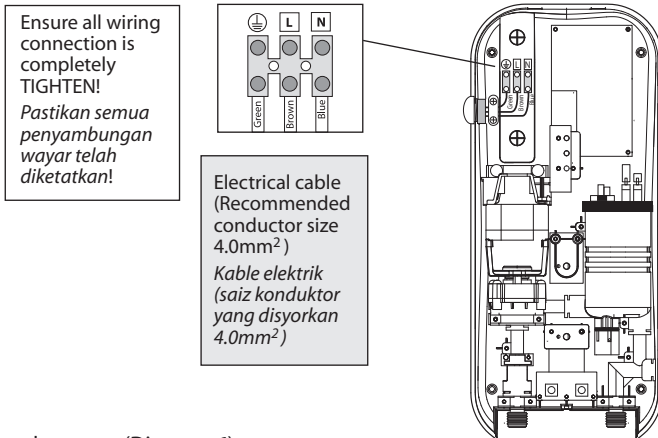

- c) Restore the cover. (Diagram 6)  
*Pasangkan penutup pemanas. (Rajah 6)*

To install cover:  
*Pemasangan penutup:*

- 1) Place top part into position & fit in nicely.  
*Posisikan penutup & ketatkan bahagian atas dahulu.*
- 2) Press firmly the bottom part until "click" to secure the cover.  
*Tekan bahagian bawah penutup sehingga bunyi "klik".*
- 3) Install screw at bottom to lock in position.  
*Selepas penutup dipasang dengan ketat, pasang skru di bahagian bawah.*

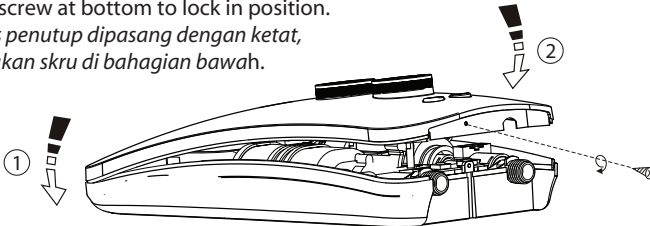
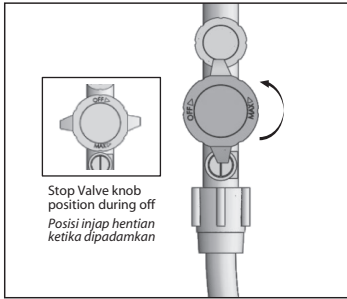
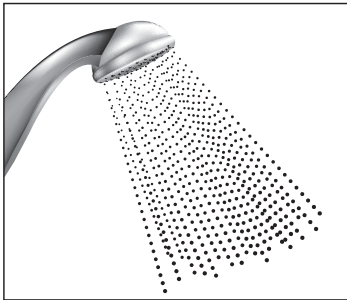

Diagram 6  
Rajah 6

## 4. OPERATION PROCEDURES / TEST RUN OF HEATER TATACARA OPERASI / PENGUJIAN PEMANAS



- 1 Turn on stop valve (anti - clockwise).  
*Hidupkan injap hentian (arah lawan jam).*



- 2 Make sure water flow starts after stop valve had been turned on.  
*Pastikan pancuran air bermula selepas injap hentian dihidupkan.*

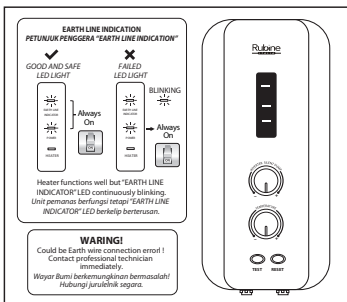

- 3 Switch on the main power supply the yellow "EARTH LINE INDICATOR" LED and green "POWER" LED would light up. Refer below "EARTH LINE INDICATION" for more detail.  
*Hidupkan bekalan kuasa utama, "EARTH LINE INDICATOR" LED kuning dan "POWER" LED hijau akan bernyala. Sila rujuk kepada "EARTH LINE INDICATION" untuk maklumat lanjut.*

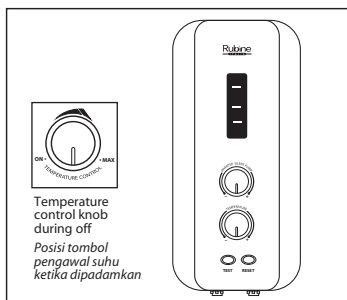

- 4 Turn on temperature control knob and red "HEATER" LED would light up.  
*Pusing tombol pengawal suhu dan "HEATER" LED merah akan bernyala.*

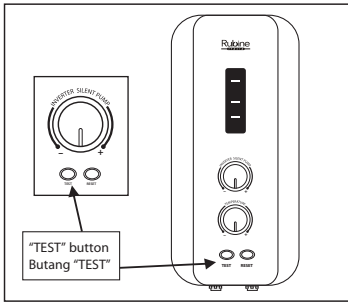

- 5 Test the ELCB by pressing “TEST” button.  
The unit should be tripped. “POWER” LED light and “HEATER” LED light would turn off.  
*Uji ELCB dengan menekan butang “TEST”.  
Unit akan diputuskan bekalan kuasa. “POWER” dan “HEATER” LED akan terpadam.*

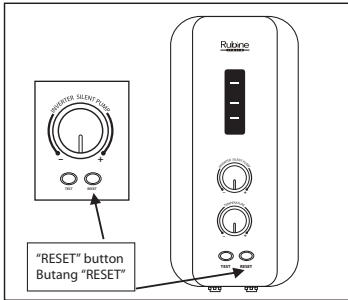

- 6 Press reset button to resume power connection.  
*Tekan butang “RESET” untuk penyambungan kuasa semula.*

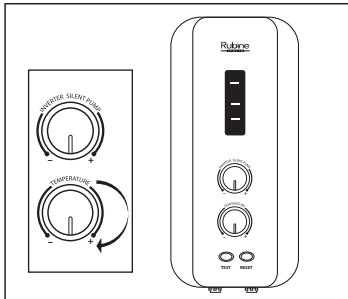

- 7 The heater is now ready for use.  
Temperature will be increased accordingly as the knob being turned clockwise from “-” to “+”.  
*Pemanas kini sedia digunakan.  
Suhu air akan meningkat sewajarnya apabila tombol dipusing mengikut arah jam dari “-” ke “+”.*

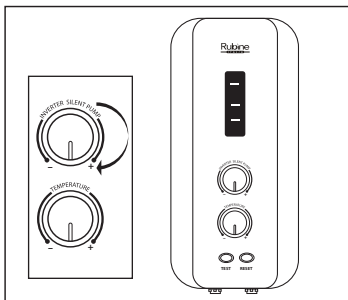

- 8 Turn the pressure control knob “Inverter Silent Pump”/ “Booster Pump” (only for pump model) clockwise from “-” to “+” for boosting a stronger shower spray.  
*Pusing tombol kawalan tekanan “Inverter Silent Pump”/ “Booster Pump” mengikut arah jam dari “-” to “+” untuk meningkat pacuran semburan.*

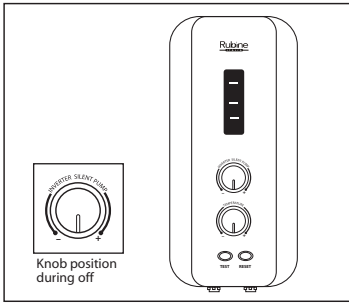

- 9 Switch off the heater and main power supply when not in use.  
Padamkan suis pemanas dan bekalan kuasa apabila tidak menggunakannya.

## 5. GENERAL MAINTENANCE PENYELENGGARAN AM

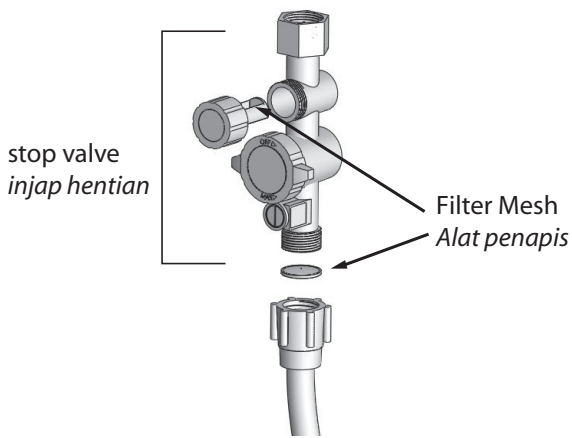
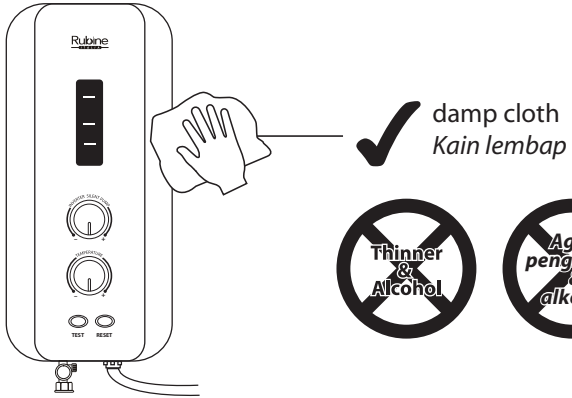

**!**

**CLEAN FILTER MESH REGULARLY  
ALAT PENAPIS MESTI KERAP DIBERSIHKAN**

## 6. TECHNICAL SPECIFICATIONS SPESIFIKASI TEKNIKAL

Electrical loading / Muatan elektrik	3.6kW 240V 50/60Hz
Other loading / Muatan lain	Please refer Electrical loading table Rujuk jadual pendawaian elektrik
ELCB sensitivity / Sensitiviti ELCB	15 mA
Operating condition / Keadaan berfungsi	Open system (Open outlet) / Sistem terbuka
Water connection / Sambungan air	Ø15mm (1/2" BSP)
Degree of protection / Tahap perlindungan	IP25
Min water flow rate / Kadar aliran air min	2 litre/ min
Min water pressure / Tekanan air min	0.2 bar ( 20kPa / 2.9psi )
Max water pressure / Tekanan air max	4 bar ( 400kPa / 58psi )
Heater dimension (mm) / Ukuran pemanas	440 (H) x 190 (W) x 87 (D)
Heater nett weight / Berat bersih pemanas	Non pump / Tanpa pam : 1.3kg Inverter Silent DC Pump / Pam Senyap Inverter DC : 1.8kg Inverter AC pump / Pam Inverter AC : 2.0kg

## 7. SCHEMATIC WIRING DIAGRAM RAJAH PENDAWAIAN SKEMATIK

INVERTER SILENT DC PUMP (F191D)  
PAM SENYAP INVERTER DC

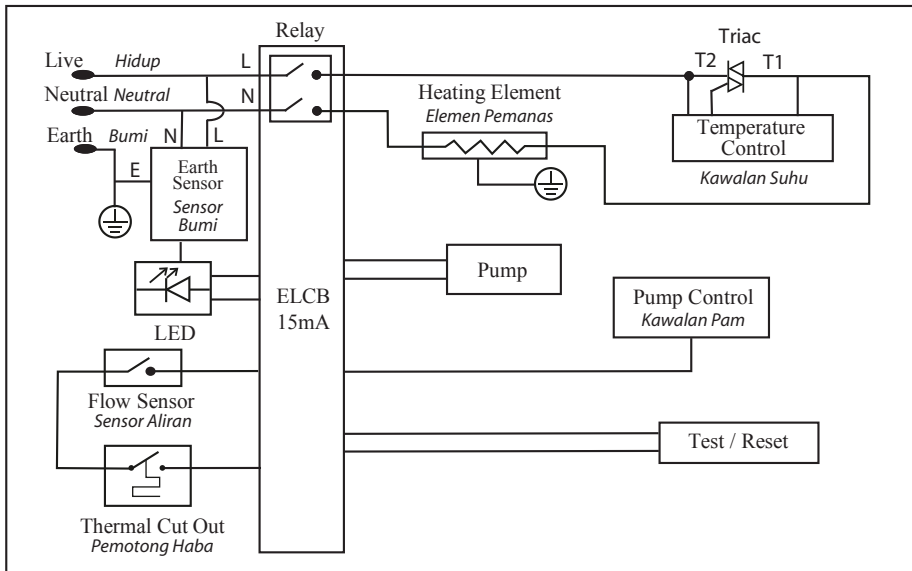

**INVERTER AC PUMP (F192A)**  
**PAM INVERTER AC**

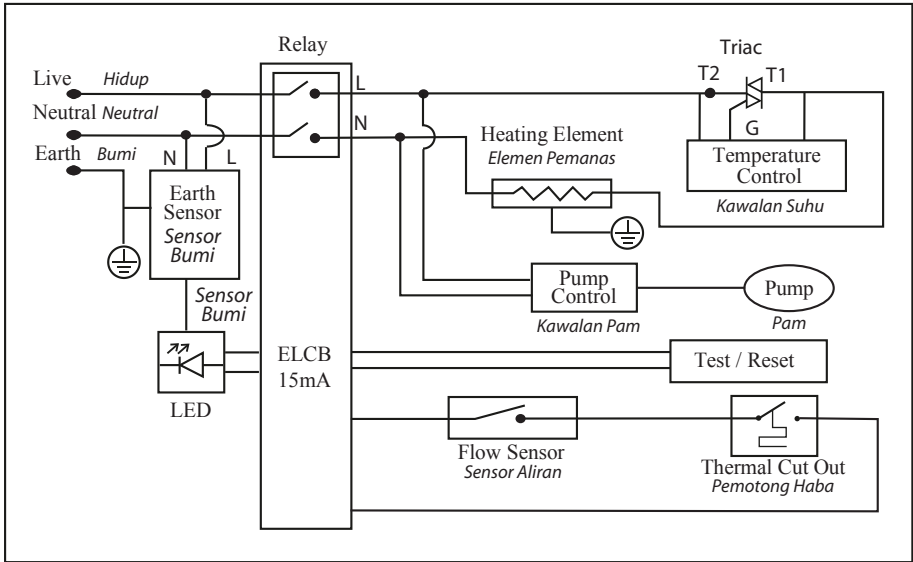

**NON-PUMP (F190N)**  
**TANPA PAM**

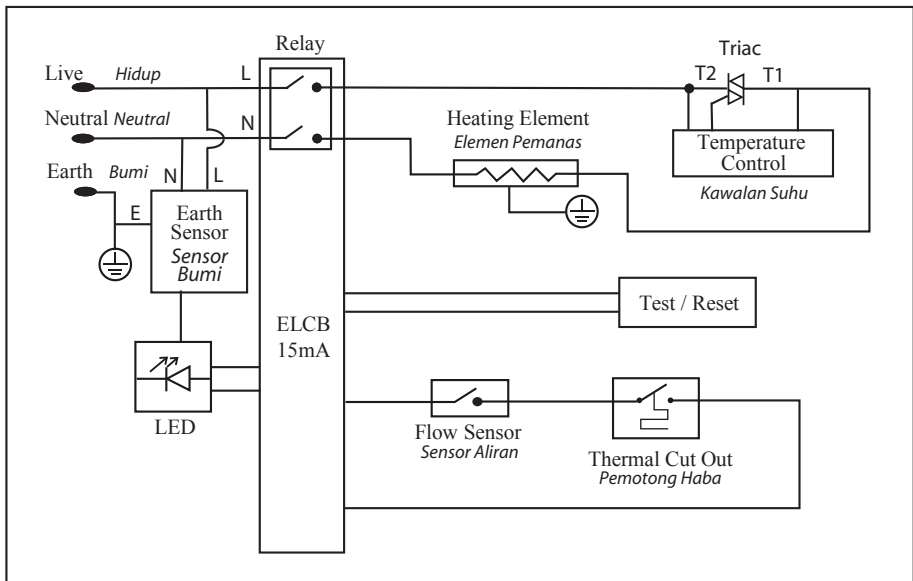

# Our Warranty

**1**

Year  
Warranty

on Internal Parts  
*pada Bahagian Dalam*

**7**

Years  
Warranty

on Heating Element  
*pada Unsur Pemanas*

**1.5**

Year  
Warranty

on Inverter AC Pump  
*pada pam Inverter AC*

**10**

Years  
Warranty

on Anti-tank Leakage  
*pada Pencegahan Tangki Bocor*

**5**

Years  
Warranty

on Inverter DC Silent Pump  
*pada pam Senyap Inverter DC*

**6** mths Warranty Extension

## Online Registration

1. Log on to [www.rubine.com.my](http://www.rubine.com.my)
2. Click on 'Support', followed by 'Product Warranty Registration' to proceed. You're required to sign up as a member.
3. You'll receive a notification of warranty registration confirmation via email.
4. Please keep your online warranty certificate for reference / future warranty claim.

## Pendaftaran Di Laman Web

1. Layari [www.rubine.com.my](http://www.rubine.com.my)
2. Klik pada 'Support', diikuti dengan 'Product Warranty Registration'. Anda dikehendaki mendaftar sebagai ahli Rubine.
3. Anda akan menerima e-mel sijil pengesahan dengan data pendaftaran jaminan.
4. Pastikan anda simpan e-mel sijil pengesahan untuk tuntutan jaminan.

# Customer Care

AFTER - SALES SERVICE:

Tel : **03-6279 8899**

Email : **ftcrm@fiamma.com.my**

OPERATION HOURS:

**09:00am – 05:00pm**

(Monday – Friday, except public holiday)

This specification is subject to change without prior notice,

FIAMMA TRADING SDN. BHD. will not be held responsible for the use of superseded or voided specification.

**rubine.com.my**



**FIAMMA TRADING SDN BHD** 330476-P (A member of Fiamma Holdings Berhad)

2-1, Wisma Fiamma, No.20, Jalan 7A/62A, Bandar Manjalara, 52200 Kuala Lumpur. Tel: 03-6279 8943